

ADJUSTASTAIRS



THE ADJUSTASTAIRS STORY

There has been a growing drive on construction projects worldwide to eliminate unsafe ladders, without the hassle of building up a scaffold to access between levels on sites. That's why SafeSmart are pleased to introduce the AdjustaStairs. This product is quickly becoming a popular choice for industries and trades that need safe and efficient temporary multi-level height access.

It is our customer base who helped us identify this need in the market. And since designing and developing our first set of portable stairs for those clients, the AdjustaStairs system has evolved into a recognisable and trusted product around the world.

When looking for market-leading portable stairs, look no further than AdjustaStairs.

SUMMARY OF BENEFITS

- Safer than a ladder – allow multiple users at once to carry tools and equipment between levels.
- 5 minutes set up time.
- Instant adjustment – simply place the stairs at the level you require, and the treads will self-level to suit the height. Once the handrails are raised and the stairs fixed top and bottom, they're ready to use – no additional sign-off or certification required.

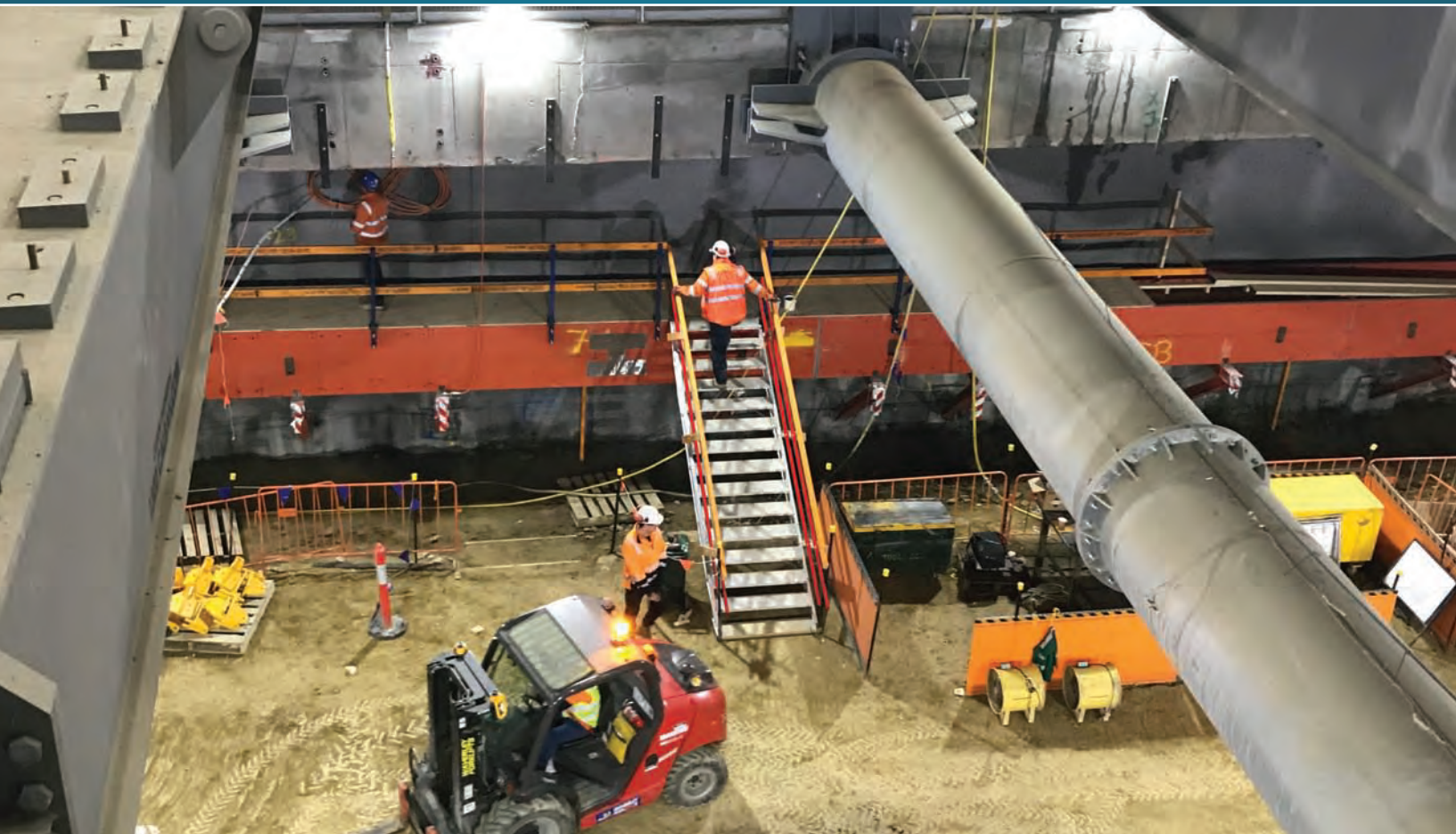

ADJUSTASTAIRS: HOW DO THEY SELF-LEVEL AND ATTACH?

This innovative design allows the treads to move with the stringers. They will self-level to provide a firm, flat surface at the desired height and pitch angle, once level, they are fixed to the support surface as shown below.

TIMBER FIXING

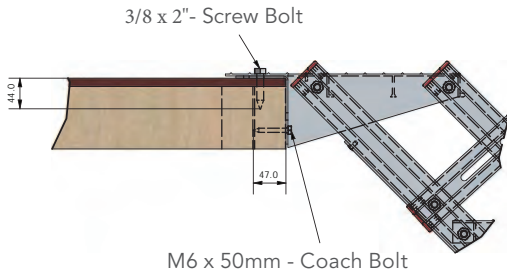

CONCRETE FIXING

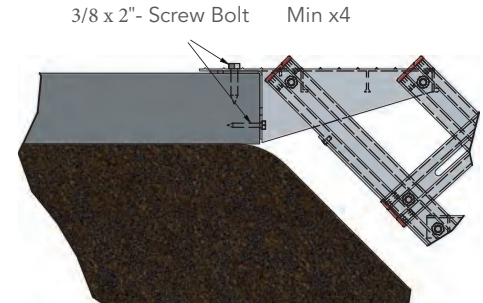

SEE PAGE 5
FOR SCAFFOLD
ATTACHMENT
FITTING

FIXING DETAILS

Recommended Fixings:
Minimum 4x 3/8 x 2" Screw Bolts
Anchors Subject to Substrate Assessment

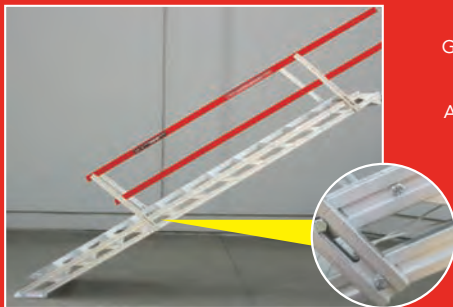
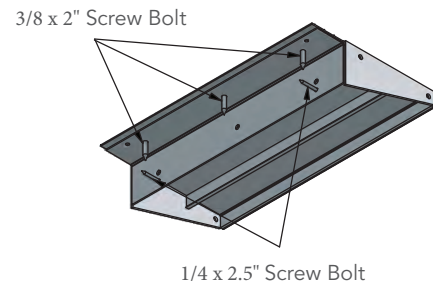
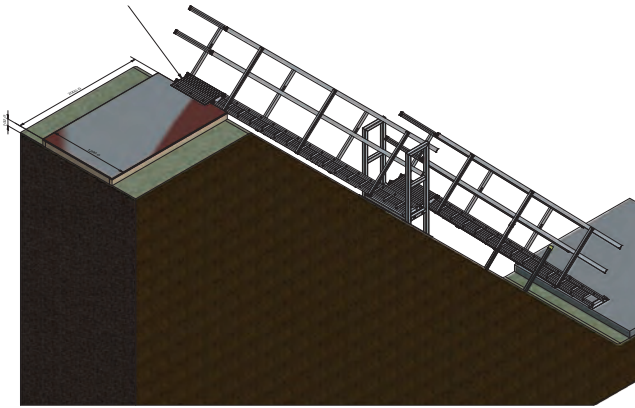

GAP BETWEEN STRINGERS DECREASES AS THE STAIRS DECLINE



GAP BETWEEN STRINGERS INCREASES AS THE STAIRS INCLINE

INCLINATION DIAGRAM

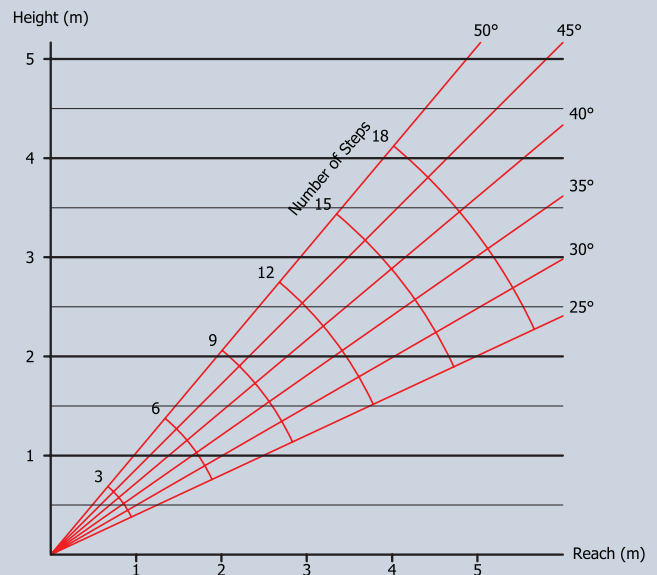

NB- National Regulation may impose other requirements. Take these into consideration.



**STAIRS
CAN BE
JOINED FOR
BATTER
ACCESS**

**90° TOP
FIXING BRACKET**



**FOLDING
HANDRAILS**

**SELF LEVELLING
TREADS**

BOLT-ON TRUSS

**ANTI-SLIP
STAIR TREADS**



**LARGE
SUPPORT FOOT**

**36" W
CRANEABLE STAIRS**



**COMPLIES WITH
OSHA
STANDARDS**



24" WIDE ALUMINUM

MODEL	STEPS	HEIGHT RANGE	WEIGHT RATING
15AS0624	6	3 - 4.8 FT	660LBS
15AS0824	8	4 - 6.4 FT	660LBS
15AS1024	10	5 - 8 FT	660LBS
15AS1224	12	6 - 9.6 FT	660LBS
15AS1424	14	7 - 11.2 FT	660LBS
15AS1624	16	8 - 12.8 FT	660LBS
15AS1824	18	9 - 14.4 FT	660LBS
15AS2024	20	10 - 16 FT	660LBS

36" WIDE ALUMINUM

MODEL	STEPS	HEIGHT RANGE	WEIGHT RATING
15AS0636	6	3 - 4.8 FT	660LBS
15AS0836	8	4 - 6.4 FT	660LBS
15AS1036	10	5 - 8 FT	660LBS
15AS1236	12	6 - 9.6 FT	660LBS
15AS1436	14	7 - 11.2 FT	660LBS
15AS1636	16	8 - 12.8 FT	660LBS
15AS1836	18	9 - 14.4 FT	660LBS
15AS2036	20	10 - 16 FT	660LBS

36" WIDE ALUMINUM HIGH ACCESS

MODEL	STEPS	HEIGHT RANGE	WEIGHT RATING
15AS2236	22	11 - 17.6 FT	1100LBS
15AS2436	24	12 - 19.2 FT	1100LBS
15AS2636	26	13 - 20.8 FT	1100LBS
15AS2836	28	14 - 22.4 FT	1100LBS
15AS3036	30	15 - 24 FT	1100LBS
15AS3236	32	16 - 25.6 FT	1100LBS
15AS3436	34	17 - 27.2 FT	1100LBS
15AS3636	36	18 - 28.8 FT	1100LBS
15AS3836	38	19 - 30.4 FT	1100LBS
15AS4036	40	20 - 32 FT	1100LBS



ACCESSORIES

MODEL	DESCRIPTION	BENEFIT
15ASHB24	Bolt-On H-Brace for 24" Wide AdjustaStairs	Increases Cap. by 500LBS
15ASHB36	Bolt-On H-Brace for 36" Wide AdjustaStairs	Increases Cap. by 500LBS
15ASSA24-3STEP	Bolt-On Step Extension Attachment for 24"	Increases Reach Height by 2 FT
15ASSA36-3STEP	Bolt-On Step Extension Attachment for 36"	Increases Reach Height by 2 FT
15ASML	Mid Landing Kit with H-Brace	Joins 2 AdjustaStairs

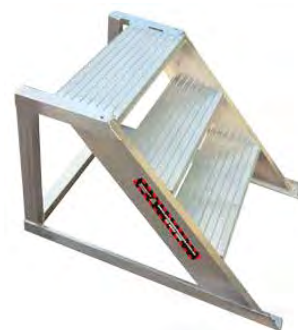

ADJUSTASTAIRS ACCESSORIES

LIFTING LUGS

- Attach to any aluminum AdjustaStairs model.

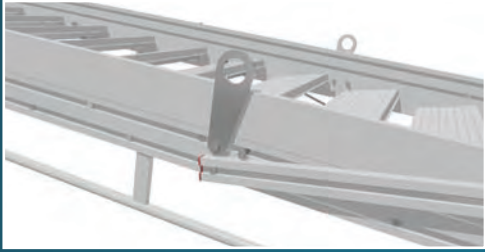

SCAFFOLD MOUNT HOOK

- Attaches to the top fixing plate of the AdjustaStairs and clamps stairs to a scaffold tubular ledger.



STRUTLOCKS

- Designed to hold AdjustaStairs at a set angle when the fixing plate cannot be secured (e.g. when used for access to a truck tray).
- Perfect for when AdjustaStairs are used on slope.



24" 3 STEP EXTENSION

- Attaches to the bottom of any AdjustaStairs model to add an extra 24" of height range.
- Can also be used as an independent step or stair where space is limited.



MID LANDINGS

- Custom sizes - made to order.



INDUSTRY APPLICATIONS

BATTER ACCESS

- Stairs will self-level to suit the angle of the batter.
- Multiple stairs can be joined end to end to create long runs.
- Top and mid landings are available
- Fixing options include: bolting top of stairs to timber sleeper or structural ply, pinning into dirt at the bottom.



HEADSTOCK ACCESS



EXCAVATION ACCESS

- Adjustability of the stairs makes them ideal for excavation access, where levels are constantly changing.



FORMWORK ACCESS

- Use AdjustaStairs instead of a ladder for your primary or secondary access
- Much quicker to set up and move than a scaffold tower.
- 36 inch W version is ideal for high-traffic sites.





FORMWORK SCREEN ACCESS

- Adjustable feature means that the stairs can be simply fitted inside formwork screens.
- Stairs can be custom made to length to fit different screens.



LIFT CORE ACCESS



RAIL ACCESS

- Electrically-safe fiberglass AdjustaStairs may be required for use inside the rail corridor.
- Set up in seconds for access from platform level to the rail line.
- Clamping options available to avoid drilling into rail platform.



TRUCK ACCESS

- Truck AdjustaStairs have an extended top lip (for grip) and strutlocks pre-fitted – no fixing required (code 15AS06 for 6 step Truck AdjustaStairs).

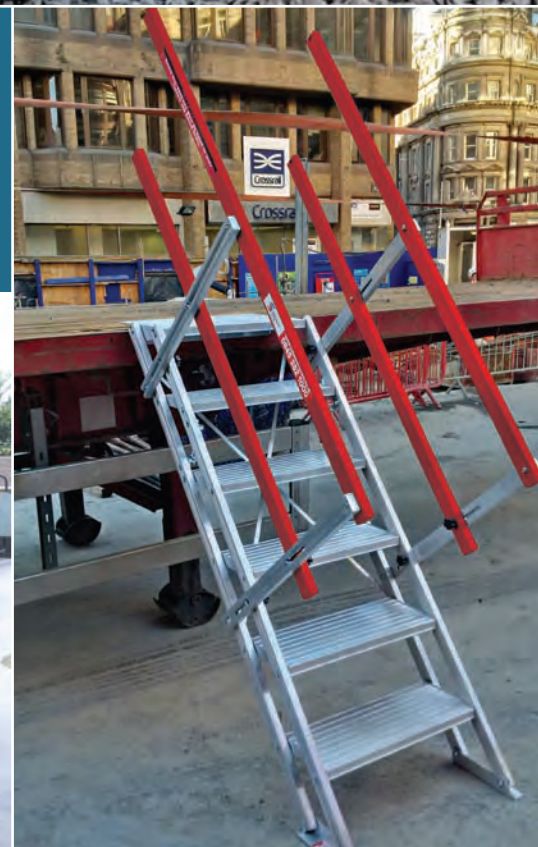



CANAL ACCESS





SAFESMART
ACCESS

Reaching new heights

LOS ANGELES

Headquarters
13238 Florence Avenue
Santa Fe Springs, CA 90670
Phone: 310 410 1525

NEW YORK

Distribution Warehouse
480 Meadow Lane
Carlstadt, NJ 07072

www.safesmartusa.com

INTERNATIONAL LOCATIONS

UK

London

CANADA

Oxbow - Edmonton

AUSTRALIA

Sydney - Melbourne

NZ

Auckland - Christchurch