

QA140HLSP series

LED Strobe Warning Lights for Heavy-Duty Equipment

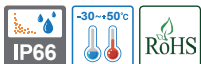

Excellent durability and shockproof by using high hardness PC material for the lens.



Bendable pole structure prevents damage from external impact.

Vibration resistant, shock-proof, dustproof, and waterproof products

Durable and enclosed product structure was produced for direct exposure to the environments of heavy equipment such as vibration and shock, dust and water.

Bendable pole structure prevents damage from external impact

Pole mount product is designed to prevented damage from external impact by bending in the opposite direction when impact occurs.



QA140HLSP LED Strobe Warning Light

Model number	Brightness type	Brightness	Voltage	Current	Certificates	Weight	Color
QA140HLSP	Standard	110Lux	DC12V	0.820A	CE DC24V Only E11	1.16kg	● R-Red ● A-Amber
			DC24V	0.600A			



QA140DLSP LED Strobe Warning Light

Model number	Brightness type	Brightness	Voltage	Current	Certificates	Weight	Color
QA140DLSP	High brightness	170Lux	DC12V	1.640A	-	1.18kg	● R-Red ● A-Amber
			DC24V	1.040A			



Technical Diagram

(Units : mm)

QA140HLSP

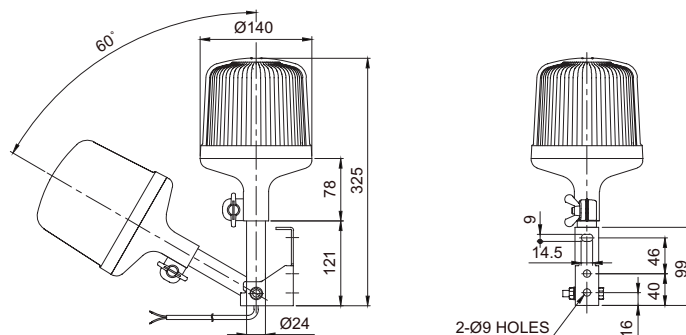

Wiring Instructions

- External power line standard : KSC3304 0.85sq×2C 400mm
- Product can be wired regardless of polarity



Customization

- Connector type wiring products



Ordering Specification

QA140HLSP	-	12	-	R
[Model number]		[Voltage]		[Color]
• QA140HLSP		• 12-DC12V		• R-Red
• QA140DLSP		• 24-DC24V		• A-Amber