

QA125HLS series

LED Strobe Warning Lights for Heavy-Duty Equipment

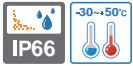

QA125HLS-Ø125mm
QA125HLSP-Ø125mm



QA125HLS



QA125HLSP



QA125HLS LED Strobe Warning Light

- Flashing rate : 60-80 flashes/min

Model number	Voltage	Current	Certificates	Weight	Color
QA125HLS	DC12V-24V	Max 1.650A	-	0.55kg	<ul style="list-style-type: none"> ● R-Red ● A-Amber

※ DC type model has a free-voltage range of 10V-30V.



QA125HLSP LED Strobe Warning Light

- Flashing rate : 60-80 flashes/min

Model number	Voltage	Current	Certificates	Weight	Color
QA125HLSP	DC12V-24V	Max 1.650A	-	1.00kg	<ul style="list-style-type: none"> ● R-Red ● A-Amber

※ DC type model has a free-voltage range of 10V-30V.



Technical Diagram

(Units : mm)

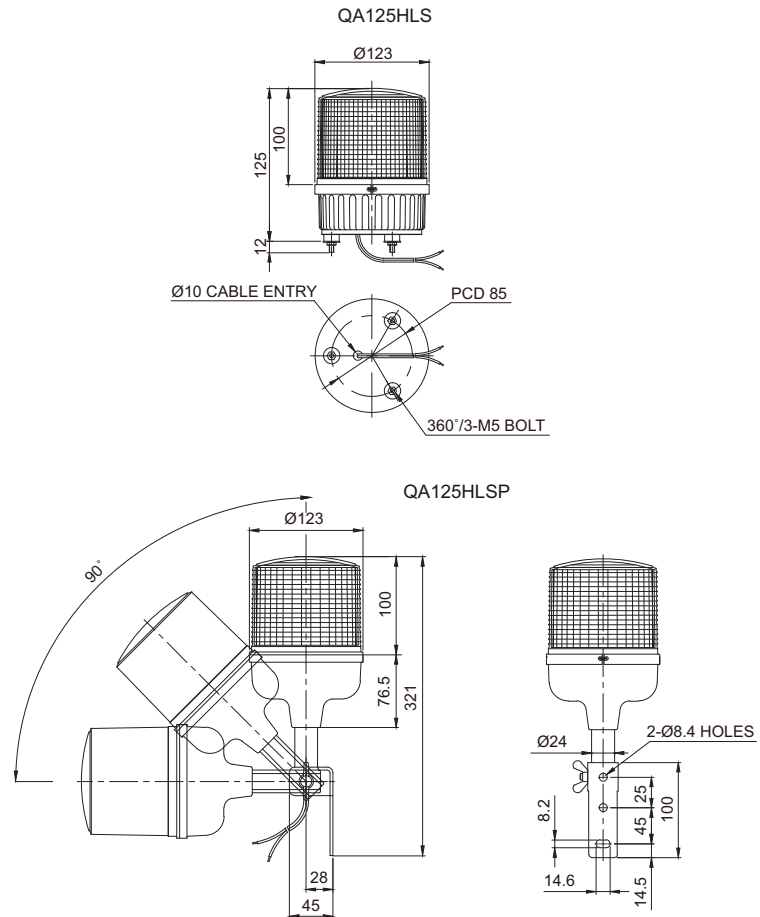

Wiring Instructions

- External power line standard : UL1015 AWG18(0.75sq)×2C 400mm
- Product can be wired regardless of polarity



Ordering Specification

QA125HLS	-	12/24	-	R
[Model number]		[Voltage]		[Color]
<ul style="list-style-type: none"> • QA125HLS • QA125HLSP 		• 12/24-DC12V-24V		<ul style="list-style-type: none"> ● R-Red ● A-Amber