

ANYKIT

**Otoscope
User
Manual**

Model No.: AKE390i

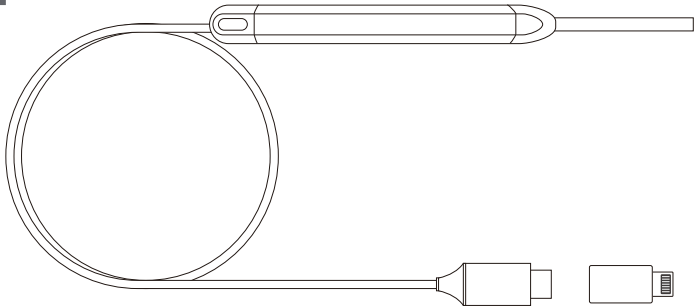

⚠ READ BEFORE USE

Please keep the user manual for future reference, you can also scan this QR code to download the PDF user manual.

By using this product, you signify that you have read, understand, and accept the terms and conditions here.

Read the following documents before using:

1. Safety Guidelines
2. Quick Start Guide
3. User Manual

It is recommended to watch all tutorial videos and read safety guidelines before using for the first time. Prepare for your first use by reviewing the quick start guide and refer to this user manual for more information It is recommended to watch tutorial videos and notices before using for the first time.

Video Tutorials

Scan the QR code to watch the AKE390i tutorial videos, which guidelines how to use the AKE390i safely.



■ ABOUT ANYKIT

Anykit is a trendy and practical tool brand. We focus on simplicity and ease of use, providing people with convenience in their everyday lives. Our products including otoscopes, endoscopes, and a variety of household tools to enable DIY enthusiasts to embrace creativity and convenience.

■ FOLLOW ANYKIT



■ INSTRUCTION

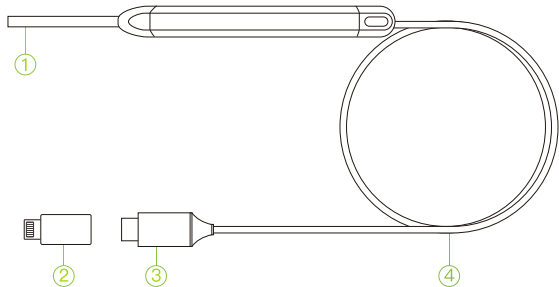

1.	Camera
2.	Lightning Connector
3.	Type-C Connector
4.	Cable



Disinfect the specula or ear spoon by wiping them with 75% alcohol solution.

■ PRODUCT SPECIFICATIONS

Camera Diameter	Cable length	Camera Lights	Focal Distance	View angle	Device Compatibility
3.9mm	5.9ft(1.8m)	6 Led Lights	0.4inch-1.2inch (10mm-30mm)	68°	Android (Type-C) iOS(Lightning)

■ INSTRUCTION

Disinfect the specula or ear spoon by wiping them with 75% alcohol solution before and after EVERY use.
For safer and cleaner ears, please install the speculum or ear spoon before use.



■ TIP ON THE SPECULUM

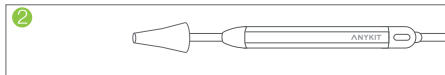
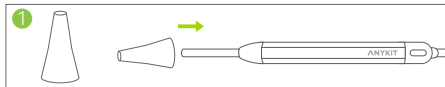

■ TIP ON THE EAR SPOON

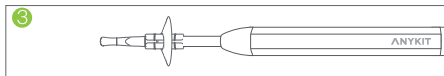
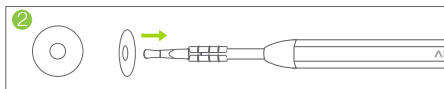
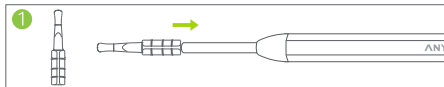

■ SOFTWARE FUNCTION

DOWNLOADING THE APP

Use the otoscop with the “**Usee Plus**” app. You can download it from Apple Store/Google Play or scan the QR code below.



Usee Plus



■ CONNECTING GUIDE

1. Plug the otoscope into your smart device
(Type-C connector for Android Phone/Tablet,
Lightning connector for iPhone/iPad)

P-1

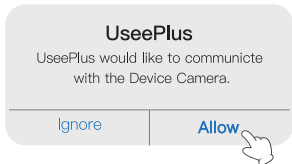

2. You'll receive a notification and click "Allow" to use it.
(P-1 for iOS)

You'll receive a notification and click "Always" to use it.
(P-2 for Android)

P-2

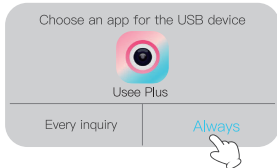

■ OPERATING INSTRUCTION

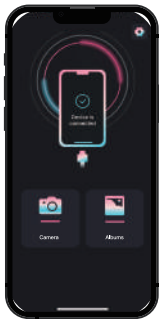

Camera: Start to use the camera

Albums: Review the photos/
videos you take

Settings: Enter into the app settings

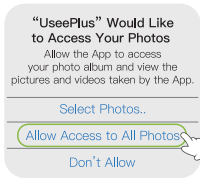
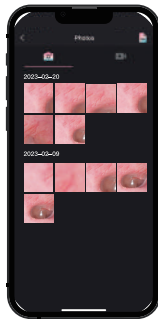

■ APP INSTRUCTION

- 1: Back
- 2: Image Rotate 90°
- 3: Color/Black and White Image
- 4: Split Screen Mode
- 5: Albums
- 6: Photo/Video
- 7: Zoom 1x/1.5x/2x
- 8: Take a photo/video

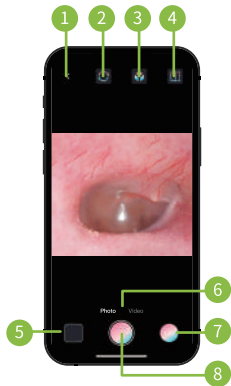

■ NOTICE

1. Disinfect the surface of the device and adapter before contacting skin.
2. Please keep the camera clean to avoid blurry image. (Refer to maintenance for how to clean the camera).
3. Please keep a focal length of about 0.4inch~1.2inch (10mm~30mm) to achieve the best quality image (placing the scope too far from your focal point may result in blurry images).
4. The ear canal is not perfectly straight, gently adjust the position of the otoscope and gently pull the top of your ear up and back to help view your eardrum easily.

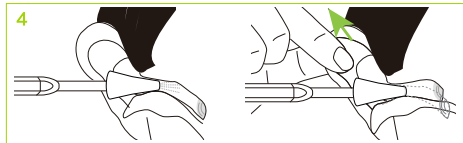
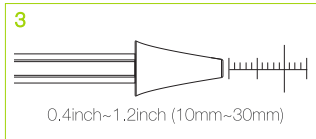

■ MAINTENANCE

To optimize the image quality and maintain personal hygiene, please following these tips to clean the camera before and after EACH use:

1. Clean the lens carefully with alcohol pads.
2. Wipe the lens grooves with an alcohol-soaked cotton swab.

This can prevent ear wax from sticking to the tip of the camera and causing blurry images. You can apply pressure when cleaning the camera to remove stubborn ear wax completely.

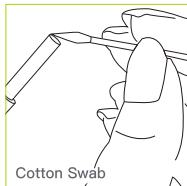
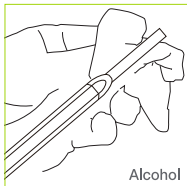

■ TROUBLESHOOTING

No pictures

1. Please ensure your device is iOS 9+ or Android 7+ with the function of OTG and UVC.
2. Please check if the camera light is on. If it's not, or if the interface isn't making good contact, please unplug and then plug it back in.
3. If you drop or mishandle the product during transportation or use, it may cause damage to the internal structure or poor contact. Please contact our customer service team for assistance. 877-899-8809, Mon-Fri. 8: 00-5: 00 PST

Frozen images

Your phone's battery may be low. Please keep your phone's battery level above 20%.

Blurry image

Please clean the camera before and after every use to keep the camera clean to avoid blurry images. Blurred images after a period of use is caused by the earwax on the camera lens. (In general, earwax is oily and can cause glare, and unclear image) If the earwax does not carefully wipe out, this will make it stick to the lens more firmly.

Cannot thoroughly clean the lens

Please follow the steps:

1. Clean the lens carefully with alcohol pads
2. Wipe the lens grooves with an alcohol-soaked cotton swab

■ WARRANTY

30-Day Guarantee	We will give you a full refund if you are not satisfied with the product.
One-Year Warranty	We offer a limited warranty that commences from the date of purchase of the product.



How to Receive Service

Visit **anykit.com** or scan the QR code for more details.

To obtain warranty service, contact our customer service team at **support@anykit.com**

■ CUSTOMER SUPPORT

If you have any questions or concerns about your product, please contact our Customer Support Team



1-877-888-7979

Mon.-Fri. 8:00-5:00 PST(US)



support@anykit.com



www.anykit.com



@anykit



Facebook Messenger



YouTube

@anykit

