

PS Series Submersible Sump Pump

PSG50-150

The PSG50-150 grinder pump is a powerful 1.5 kW single-phase unit designed for residential and light commercial applications. The pump is fitted with a stainless shredding mechanism to reduce solids found in raw sewage, enabling discharge through small diameter pipework as opposed to larger diameters required for gravity-fed systems.

Quiet and trouble-free, these pumps are ideally suited for residential dwellings, shacks, marinas and pressure sewer schemes.

Technical data

| | |
|-----------------------|-----------------------|
| Outlet (mm) | 50 BSP |
| Max flow rate (L/s) | 5.6 |
| Max head pressure (m) | 20 |
| Solids handling | Grinder |
| Power (kW) | 1.5 |
| Current (A) | 9.5 |
| Voltage (V) | 240 |
| Speed (RPM) | 2900 |
| Casing | Cast iron |
| Motor housing | Stainless steel |
| Cable details | 10 m length, H07 RN-F |
| Mounting | Free standing |
| Weight (kg) | 27 |

Performance curve

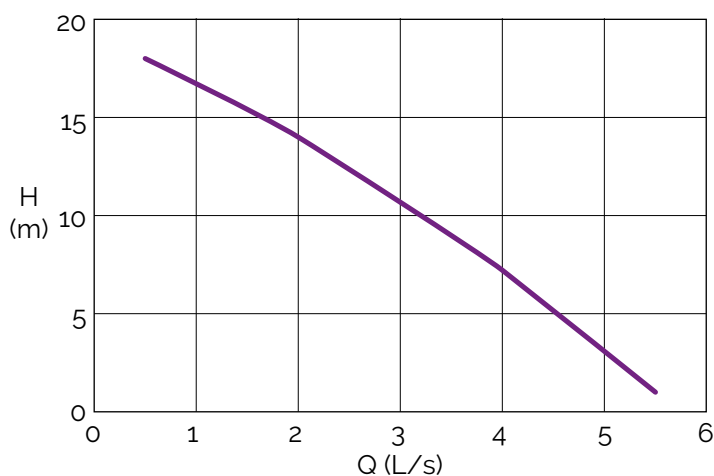

Features

- single phase
- in-built float switch for automatic operation
- hardened stainless grinder mechanism
- cast iron pump casing
- stainless steel motor housing
- oil lube double mechanical seals.

Dimensions (mm)

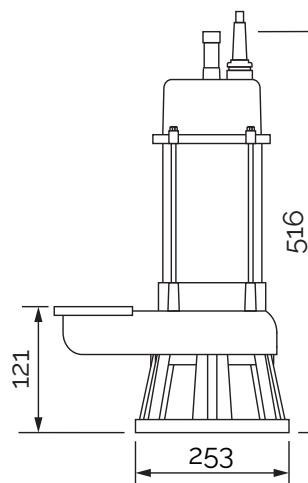

**Pump Stations
Direct**

©2022 pumpstationsdirect.com.au