

RKIN
WATER SYSTEMS

Hydrogen-Rich Reverse Osmosis Water System

RKIN U1

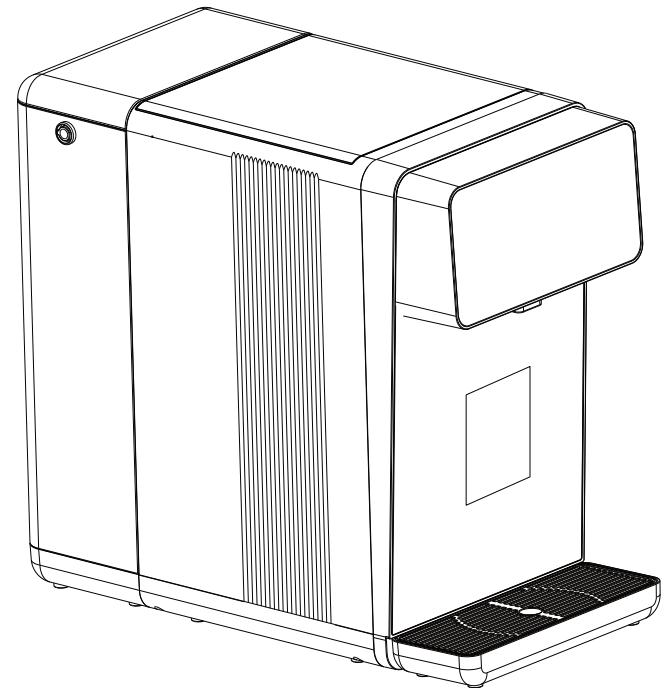

Please keep this manual, including the service and warranty sections, for future use. If you have questions about U1's setup, operation, or maintenance, please visit <https://rkin.com/guide/> or call 1-800-803-4551 for technical assistance.

Contents

Introduction and included parts list	01
Operation conditions.....	02
Technical specifications.....	03
Parts description.....	04
U1 Functions.....	05
Start-up and first-use instructions.....	07
Daily use.....	09
Filter cartridge replacement.....	11
Hydrogen module replacement.....	12
Consumables.....	13
Troubleshooting, long-term storage, and shipping.....	14
Error codes.....	15
Limited warranty.....	16

Introduction

Congratulations on the purchase of your RKIN U1 water system. RKIN water filters are among the best appliances you can find on the market to improve water taste and quality.

With the water quality of our environment worsening, we have been prompted to design and manufacture a compact, domestic reverse osmosis water filter to meet these challenges with the highest quality solutions.

U1 adopts reverse osmosis filtration, SPE hydrogen production, instant heating, and water cooling technologies that are integrated into a single space-saving countertop appliance.

With RKIN U1, you will enjoy the improved water taste for drinking, coffee, ice cubes, or any other drinking water use. Reverse Osmosis filtered water also enhances the flavor of food when cooking. Enjoy healthier water for your whole family.

Your RKIN U1 will provide many benefits and advantages:

- Reverse Osmosis and UV water purity
- Hydrogen-enriched, alkaline, and negative ORP water
- Hot or cold water temperature control
- Zero-installation and elegant compact design

Included Parts List

U1 Water System	1
Supply Tank	1
Magnetic Drip Tray	1
Filter and hydrogen membrane removal tool	1
Manual	1

Operation conditions

- Use only room temperature water 68 - 78 °F (20-26 °C)
- The ambient temperature must be between 40 and 104 °F (4 and 40 °C.)
- Keep the system away from extreme temperatures, like cooking surfaces, and extreme environmental conditions
- Keep the unit away from direct sunlight
- Keep the unit on the level surface at all times
- Keep the unit away from children to avoid scalding
- Unplug the unit before repair, inspection, or filter replacement
- Avoid blockage of the dispenser nozzle with a cup or other water vessel rim to avoid damage and injury from hot water
- Dispensing water immediately after hot water might cause the initial volume of water to be hot

Do not use with microbiologically unsafe water, of unknown quality, or without adequate disinfection before or after the system. If the water being filtered is from a public water supply, it will comply with requirements, and your RKIN U1 Water System will substantially improve the water quality.

If the water to be filtered is not from a public water supply or is of unknown origin, to ensure proper purification, contact RKIN or your dealer to advise you on the most appropriate physical, chemical, and bacteriological water treatment prior to use.

Effect of TDS concentration in the inlet water

The production rate and water quality will vary depending on the TDS content (Total Dissolved Solids) and the filtered water temperature. Water with a lower temperature and higher TDS will be filtered at a slower rate than water that is warmer or of a lower TDS.

- It is recommended to use water with a maximum hardness of 25 grains to obtain optimum performance.
- If the inlet water is of hardness greater than 25 grains or contains high concentrations of iron, manganese, alum, or hyperchlorination, there may be a reduction in membrane life and performance of certain components of the water system.

RKIN U1 is designed for TDS up to 800 ppm. For TDS above 800 ppm, consult your dealer. (If the water being filtered is from a public water supply, it will comply with requirements for water to be used for the RKIN purifier.)

Technical specifications

Model	RKIN U1
Rated voltage	110V
Rated frequency	60Hz
Rated power	1500W
Rated heating power	1400W
Rated refrigeration power	68W
Electrical power consumption	0.1kW / 24h
Water heating capacity	16L / h($\geq 194^{\circ}\text{F}$)
Water production flow	30L / h
Working pressure	0.4~0.6 MPa
Applicable water source	City water / treated well water
Applicable water temperature	41-100 $^{\circ}\text{F}$
Water tank capacity	1.58 gal / 0.66 gal
Net weight	24.25 lb
Dimensions	18.7 x 9.4 x 16.9 in

Parts description

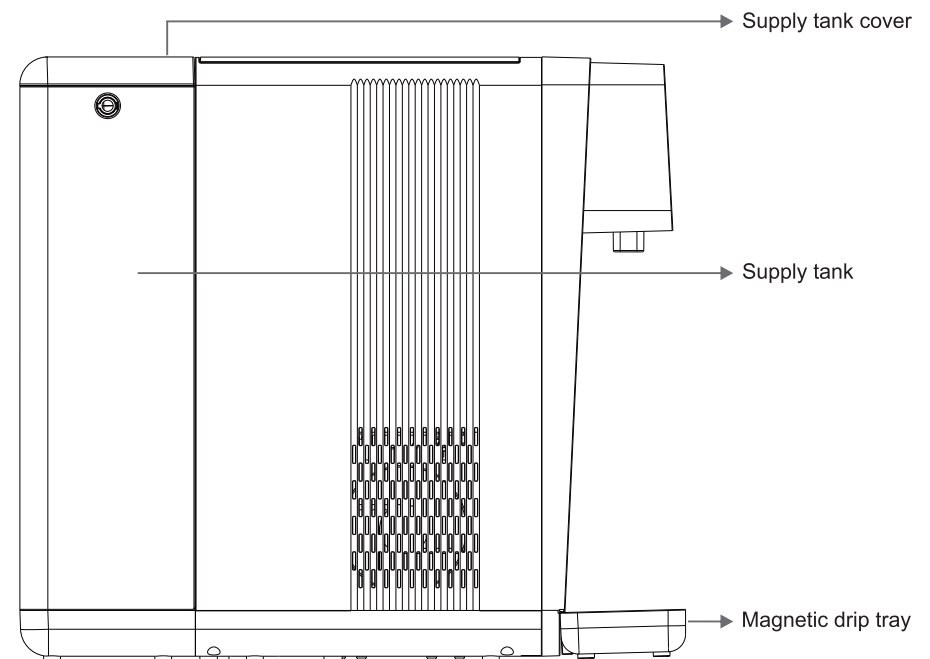
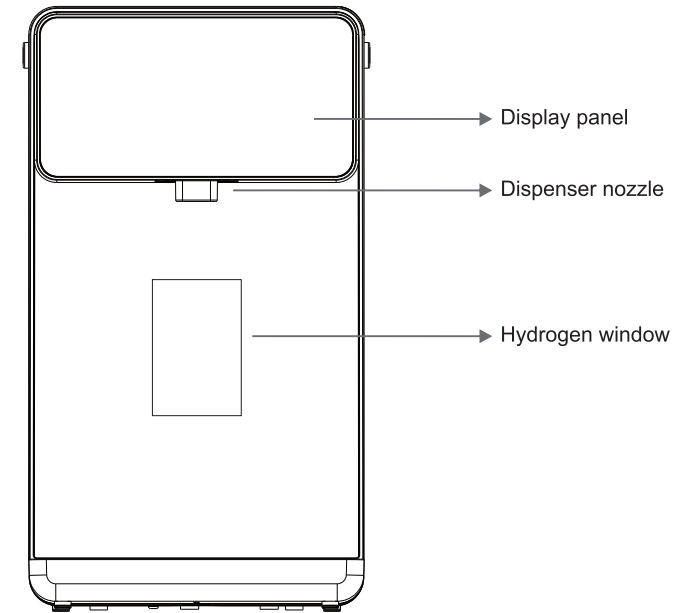



U1 Functions



Power  Indicates that the system is plugged into the electrical outlet. Press and hold for 2 seconds to turn the standby mode ON or OFF.

Rinse  Rinse cycle to drain and flush the system, a duration of about 6 minutes. To activate, press and hold the "Rinse" button for 3 seconds. Use the rinse cycle when using the system for the first time, when any of the filter(s) has been replaced, the system hasn't been used for 3 days or more, or two weeks or more have passed since the last "Rinse" cycle.

Filter Life  Filter life indicator. Lights up white when the remaining filter life is above 20%. Once filter life drops below 20%, the light turns yellow. The indicator light will turn red when the filter life has reached the end.

Reset  Once the filter(s) has been replaced, reset the filter life indicator by pressing and holding the "Reset" button for 3 seconds, then select the filter element by pressing on the "1", "2", or "3" buttons under the "Filter Life" label. Once the desired filter has been selected, press and hold the "Reset" button again for 3 seconds to complete the filter life indicator reset.

Filtering  U1 is actively Filtering Water when the "Filtering" notification lights up solid. The flashing "Filtering" notification indicates the filters are being flushed.

Fresh Water  The supply tank is ready for a refill. **Important** - Dump any remaining water in the supply tank and only then refill the "fresh tap water" section with municipal or pre-treated well water.

No Water  No filtered water is left, refill the supply tank and wait for this indicator to turn off.

Lock  Child lock safety button. Press it first to unlock the water dispensing before selecting Coffee, Tea, or Hot temperatures.

Small Cup  Press to select a "Small cup" water amount. The preset amount is 5 fluid ounces, with adjustment to 7 and 9 ounces by pressing "-" or "+" buttons. The system will dispense the previously used water amount if no selection is made.

Big Cup  Press to select a "Big cup" water amount. The preset amount is 10 fluid ounces, with adjustment to 12, 14, and 16 ounces by pressing "-" or "+." Press and hold "Small Cup" and "Big Cup" together to dispense all filtered water within the system - about 1/2 gallon when the internal storage of filtered water is full.

Normal  Press to select ambient temperature water.

Cold  Press to select cold temperature water at ≤ 59 °F. Alphanumeric notification display will show: OFF when the water cooler is turned off (press and hold the "Cold" button for 3 seconds to turn on or off), PREP while cooling, and COOL once the water has reached maximum cold temperature when the "Cold" button is pressed.

Milk  Press to select baby formula temperature water, by default 118 °F, with adjustment from 109 to 127 °F by pressing "-" or "+" buttons.

Coffee  Must first press the "Lock" button to use. Press to select "Coffee" temperature water, by default 185 °F, with adjustment from 167 to 185 °F by pressing "-" or "+" buttons.

Tea  Must first press the "Lock" button to use. Press to select "Tea" temperature water, by default 194 °F, with adjustment from 176 to 203 °F by pressing "-" or "+" buttons.

Hot  Must first press the "Lock" button to use. Press to select "Hot" - boiling temperature water, by default 212 °F, with adjustment from 194 to 212 °F by pressing "-" or "+" buttons.

Hydrogen  Press to turn the hydrogen function on or off. When hydrogen functionality is ON, the Alphanumeric display shows hydrogen content in PPB(parts per billion), and the button color turns blue. When hydrogen functionality is OFF, the Alphanumeric display shows filtered water quality TDS(total dissolved solids) content in PPM(parts per million), and the button color turns white. The hydrogen function is on by default.

-  Reduces water volume or temperature. Press "-" and then select the water volume(small/big cup) or any warm/hot temperature button to decrease by 1°F or 1-2 ounces. **Note:** This button has reduced sensitivity to prevent accidental setting changes.

+  Increases water volume or temperature. Press "+" and then select the water volume(small/big cup) or any warm/hot temperature button to increase by 1°F or 1-2 ounces. **Note:** This button has reduced sensitivity to prevent accidental setting changes.

Dispense  Press to dispense filtered water. Stays white when dispensing ambient temperature water. Turns red when dispensing warm or hot water. Turns blue when dispensing cold water.

Start-up and first-use instructions

- Step 1** Remove the U1 water system and the drip tray from the packaging and place them on a convenient and level surface like a countertop or table within three feet (1 meter) of an electrical outlet.

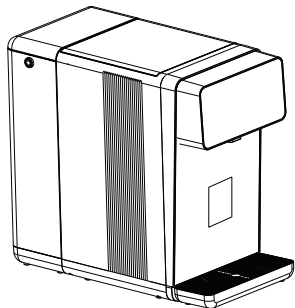

- Step 2** Remove the supply water tank and completely empty it if needed. Fill the “fresh tap water” compartment only with tap water up to the “max” line, place the tank back onto the system, and close the lid of the supply water tank.

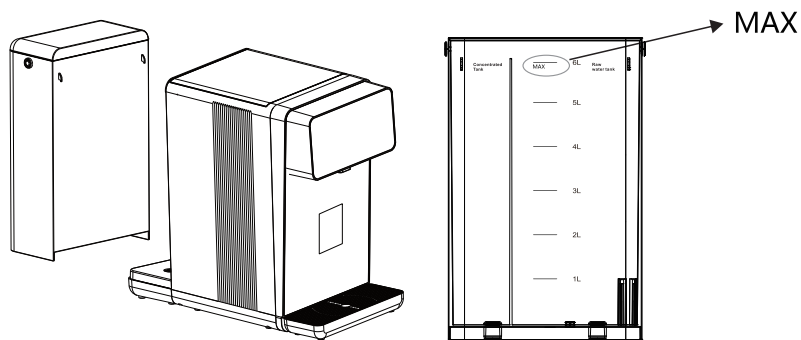

- Step 3** Plug in the electrical cord into the power outlet. Press and hold the power key for 2 seconds. The system will automatically start filtering water.

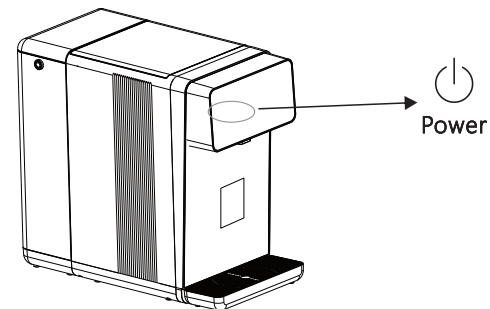

- Step 4** Place 1 gallon or larger empty container under the dispenser (water spout in front of the unit) to collect water that will dispense during the rinse cycle.

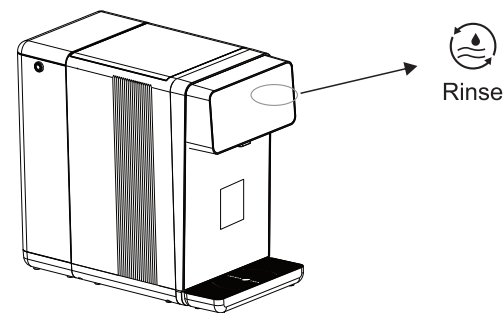

- Step 5** Once the “Fresh Water” notification is displayed. Press and hold the “Rinse” button for 3 seconds. Wait for the process to finish in about 6 minutes.

- Step 6** To ensure proper flushing of filters repeat steps two, four, and five above two more times for a total of 3 rinse cycles.

Daily use

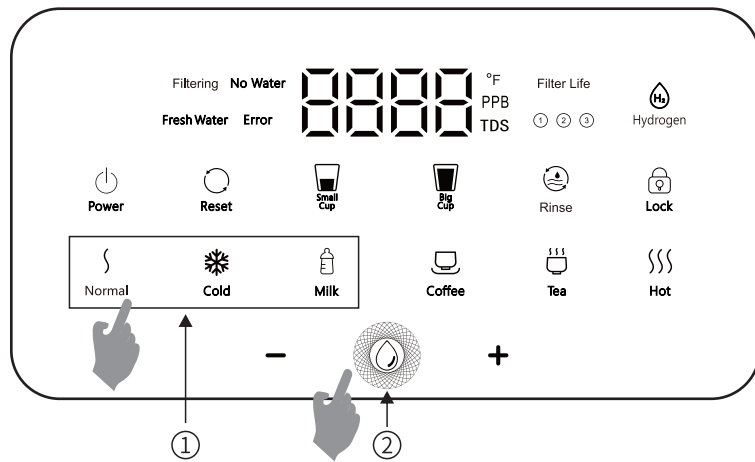

1. Select water temperature by pressing the “Normal,” “Cold,” or “Milk” button. The system will default to the previously used water volume.
2. Press the dispense button to dispense water. The dispense button can be pressed again to stop water from dispensing.

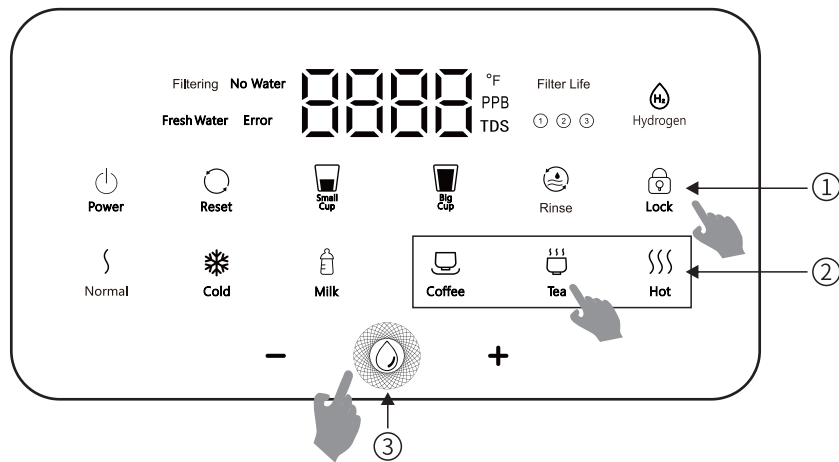

1. To disarm the child lock safety feature and dispense hot water, press the “Lock” button. The system will default to the previously used water volume.
2. Press the “Coffee,” “Tea,” or “Hot” button.
3. Press the dispense button to dispense water. The dispense button can be pressed again to stop water from dispensing.

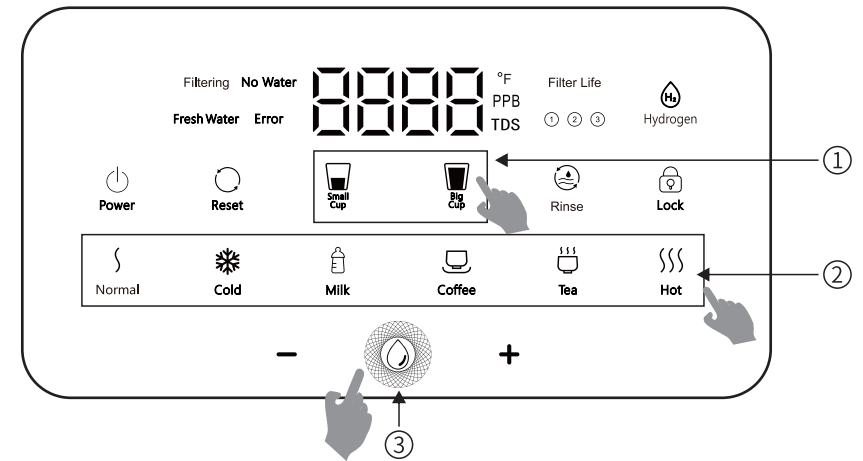

1. Select water volume by pressing the “small cup” or “Big cup” buttons.
2. Select water temperature. For “Coffee,” “Tea,” or “Hot” selections, press the “Lock” button first to disarm the child lock safety feature.
3. Press the dispense button to dispense water. The dispense button can be pressed again to stop water from dispensing.

Note:

- (1) To avoid injury, keep away from the dispenser nozzle when dispensing hot water.
- (2) During the first use, If water quantity is NOT selected, the water quantity will default to 5 ounces.
- (3) To avoid damage to the heating assembly from dry heating, please first dispense ambient temperature water during the first use of the U1.
- (4) During the first use, some air may be trapped internally, and the hydrogen water tank may appear partially filled. The air will escape with regular use, and the hydrogen tank will be filled entirely.

Customizing water temperature and volume

Press the “-” or “+” button and then select the desired setting button (Milk, Coffee, Tea, Hot, Small cup, Big cup). Current temperature and water volume are displayed via the alphanumeric display 0000. Press the “-” button to decrease the water temperature by 1 °F or volume by 1-2 ounces. Press the “+” button to increase the water temperature by 1 °F or volume by 1-2 ounces. Wait 5 seconds for the selection to be saved.

Water Cooler

When using the water cooler function for the first time, press the “cold” button, followed by pressing the dispense button to flush out any air that might be trapped in the water lines.

Alphanumeric notification display will show: OFF when the water cooler function is turned off (press and hold the “Cold” button for 3 seconds to turn it on or off), PREP while cooling, and COOL once the water has reached maximum cold temperature when the “Cold” button is pressed.

Filter cartridge replacement

Step 1 Turn off the water system, unplug it from the electrical outlet, and remove the old filter cartridge(s)

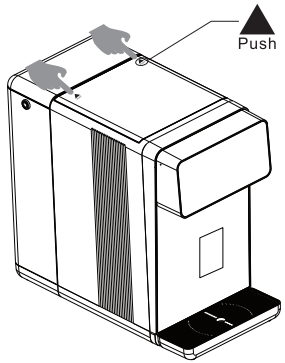

Press the "Push" button to open the filter cover;

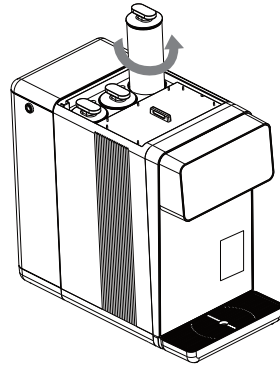

Rotate the filter cartridge counterclockwise; The included filter removal tool can be used for additional leverage. Remove the filter cartridge from the water system by pulling it upward;

Step 2 New filter cartridge installation

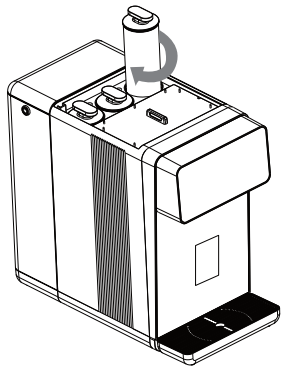

Insert the new filter cartridge, align the arrows on the top of the filter cartridge with arrows on the system, then rotate it clockwise to lock it in;

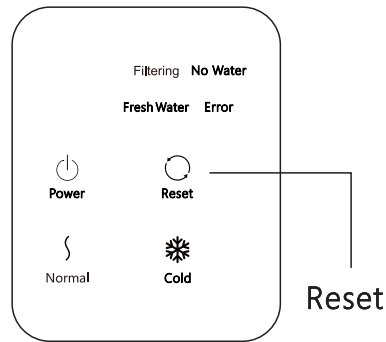

Reset the filter life indicator by pressing and holding the "Reset" button for 3 seconds, then select the filter element by pressing on the "1", "2", or "3" buttons under the "Filter Life" label. Once the desired filter has been selected, press and hold the "Reset" button again for 3 seconds to complete the filter life indicator reset.

Hydrogen module replacement

Step 1 Make sure the internal water storage is drained by running a "rinse" cycle and carefully lay down the machine on the side. Remove the hydrogen membrane opening cap by unscrewing the retainer screw. Remove the hydrogen membrane using the supplied "Filter and hydrogen membrane removal tool" to turn it counterclockwise.

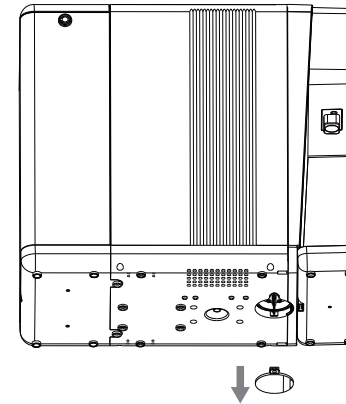

Step 2 Install the new hydrogen membrane by turning and tightening it clockwise until very snug. Reinstall the hydrogen membrane opening cap and the retainer screw.

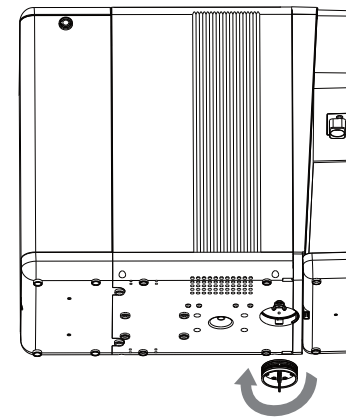

Warning

Only use genuine RKIN filter cartridges to ensure the safety of your drinking water and the longevity of your U1 water system. Please contact us for help with replacement or ordering genuine replacement parts. Please visit RKIN.com or call us at 1-800-803-4551.

Consumables

Part number	Part name	Function	Estimated lifespan
RC-QT-PAC	RKIN 2 in 1 Sediment and Carbon Filter QT Series	Sediment filter- filters sand, sediment, and rust. Activated carbon filter - reduces harmful chemical residues and carcinogens such as VOCs, THMs, pesticides, foul odors, and bad taste.	6-12 months
RC-QT-RO	RKIN 200 GPD Encapsulated Reverse Osmosis Membrane QT Series	Purifies water by blocking virtually all harmful contaminants.	12-24 months
RC-QT-CF	RKIN AlcaPure Alkaline Post Filter QT Series	Returns beneficial minerals, like calcium and magnesium, to purified water for the best taste.	6-12 months
RC-HGPEM	RKIN U1 Hydrogen Module	Creates antioxidant hydrogen-enriched water	6-12 months

Troubleshooting

Symptom	Cause and solution
No filtered water is produced	1. The water supply tank is empty or incorrectly placed. Check to ensure the supply tank has water and is properly seated in the system
	2. Filter cartridges are plugged up. Replace filter cartridges
U1 is taking longer than expected to produce filtered water	1. Water in the supply tank is too cold, below room temperature. Fill the supply tank with fresh room temperature water
	2. Filter cartridges are plugged up. Replace filter cartridges
Water does not taste good	1. Filtered water is stale. Run a "Rinse" cycle
	2. The AlcaPure post filter has been exhausted. Replace the filter cartridge - MPN RC-QT-CF
	3. The reverse osmosis membrane failed. Replace the filter cartridges - MPN RC-QT-RO and RC-QT-PAC
No hot water	1. Make sure the machine is plugged into a properly grounded outlet
	2. Wait 1-2 hours for the overheating protection circuit to reset
No cold water	1. Make sure the machine is plugged into a properly grounded outlet
	2. Make sure the water cooler function is turned on
No hydrogen water bubbles are visible in the hydrogen window	1. Make sure the hydrogen function is turned. The hydrogen cycle has been completed and is now in standby mode. Dispense some water to restart the hydrogen cycle
	2. If there is no water in the hydrogen window, dispense some water to remove air from the system and allow the hydrogen tank to fill
	3. The hydrogen module has been exhausted and needs to be replaced. Replace the hydrogen module - RC-HGPEM

Long-Term Storage And Shipping

Please contact RKIN by visiting rkin.com, via email at info@rkin.com, or by calling 1-800-803-4551 to obtain instructions for long-term storage or shipping of previously used U1.

Error codes

Record the error code first when a fault occurs, then turn off the power before proceeding with troubleshooting steps.

Error	Reason	Troubleshooting
E1	The water filtration cycle is taking over 120 minutes	Check for leaks. Make sure the water in the supply tank is at room temperature. Replace the plugged-up filters.
E2	Inlet water temperature NTC open circuit	The heating circuit is disconnected or faulty. Call customer service
E3	Outlet water temperature NTC open circuit	The heating circuit is disconnected or faulty. Call customer service
E4	The water temperature in the system is below operating temperature	Use room-temperature water in the supply tank
E6	A heating circuit board fault is detected	The heating circuit needs to be replaced. Call customer service
E7	Overheating of the insta-hot module	Unplug the water system from the electrical outlet and wait a few minutes for the system to cool down

Limited Warranty

What your warranty covers:

If any part of your RKIN Reverse Osmosis system is defective in workmanship (excluding replaceable filters and membranes), return the system after obtaining a return authorization (see below), within 1 year of the original retail purchase, RKIN will repair or, at RKIN option, replace the system at no charge.

How to obtain warranty service:

For warranty service, call 1-800-803-4551 for a return authorization number and return address. Then, ship your reverse osmosis unit to the address provided, freight and insurance prepaid, with proof of original purchase date. Please include a note stating the problem. RKIN will repair or replace it and ship it back to you.

What this warranty does not cover: this warranty does not cover defects resulting from improper installation (contrary to RKIN printed instructions), from abuse, misuse, misapplication, improper maintenance, neglect, alteration, accidents, casualties, fire, flood, freezing, environmental factors, water pressure spikes or other such acts of god. This warranty does not cover any equipment that is installed or used outside the United States of America and Canada.

Limitations and exclusions: RKIN will not be responsible for any implied warranties, including those of merchantability and fitness for a particular purpose. RKIN will not be responsible for any incidental or consequential damages, including travel expenses, telephone charges, loss of revenue, loss of time, inconvenience, loss of use of the equipment, and damage caused by this equipment and its failure to function properly. This warranty sets forth all of RKIN's responsibilities regarding this equipment.

Other conditions: If RKIN chooses to replace the equipment, RKIN may replace it with reconditioned equipment. Parts used in repairing or replacing the equipment will be warranted for 90 days from the date the equipment is returned to you or for the remainder of the original warranty period, whichever is longer. This warranty is not assignable or transferable.

Your rights under state law:

Some states do not allow limitations on how long an implied warranty lasts, and some states do not allow the exclusion or limitation of incidental or consequential damages, so the above limitations or exclusions may not apply. This warranty gives you specific legal rights, and you may have other legal rights which vary from state to state.

For technical support, warranty service, and consumables, please visit [RKIN.COM](https://rkin.com) or call us at 1-800-803-4551.

RKIN | 2331 Bruner Ln. #3 | Fort Myers, FL | 33912 | USA

Easy-to-follow video walkthroughs and user guide: <https://rkin.com/guide/>