

RKIN

WATER SYSTEMS

Connected Series

Softener & Filter Valves



Installation & Operation Manual

General Warnings.....	Page 1
Installation Requirements/Procedure.....	Page 2 - 8
Operation, Care and Cleaning.....	Page 9
Utilizing Bluetooth.....	Page 10 - 14
Softener Dashboard.....	Page 10 - 11
Filter Dashboard.....	Page 12 - 13
Programming the Control Valve.....	Page 15 - 16
Powerhead Assembly.....	Page 17
Control Valve Parts List.....	Page 18
Bypass Assembly & Parts List.....	Page 18
Valve Body Assembly.....	Page 19
Valve Body Assembly Parts List.....	Page 20
Service Procedure.....	Page 21 - 22
Troubleshooting.....	Page 23 - 24
Error Codes.....	Page 25
Warranty Information.....	Page 26

**WARNING****Lubricants**

Do NOT use Vaseline, oils, hydrocarbon lubricants or spray silicone anywhere! Petroleum base lubricants will cause swelling of o-rings and seals. The use of other lubricants may attack plastic Noryl[®]. It is recommended that Dow Corning[®] silicone grease be used as a lubricant for all control valves. Dow Corning[®] 7 Release Compound is used in the manufacture of the control valves. (Part # DOW-7)

Sealants

Pipe dope and liquid thread sealers may contain a carrier that attacks some plastic materials. It is recommended that Teflon[®] tape be used to seal plastic Noryl[®] threaded fittings.

NORYL is a registered trademark of SABIC Innovative Plastics IP B.V.



INSTALLATION REQUIREMENTS

PLEASE NOTE THESE SPECIFICATIONS BEFORE PROCEEDING

OPERATING PRESSURE RANGE : 20 - 125 PSI

OPERATING TEMPERATURE RANGE : 33° F - 120° F

INLET/OUTLET PIPE SIZE : 3/4" or 1"

PLEASE COMPLY WITH ALL APPLICABLE PLUMBING CODES

PROTECT THE SOFTENER AND PIPING FROM FREEZING TEMPERATURES

NOTE: Please read the entire Owner's Manual and Instructions before installation. This Owner's Manual must stay with the unit.

-How A Water Softener Works-

Water hardness is derived from Calcium and Magnesium minerals that have been dissolved into the water under the earth's surface. These minerals are found in limestone deposits and are the source of hard water. The amount of hardness in a given water supply is dependent upon the quantity of Calcium and Magnesium present and the length of time water has been in contact with them. This can vary dramatically from well-to-well and, for this reason, a water analysis is imperative in order to determine the proper treatment method. The degree of hardness increases as the concentration of Calcium and Magnesium "ions" increase and is measured in **Grains Per Gallon (gpg)**.

The problem of hard water in the home/business comes to light in many facets of daily use. Water spots and scum left behind on bathtubs, fixtures and showers; wear and tear on appliances; calcium build-up in hot water heaters and piping; and, greater amounts of soap and detergents being used are just a few examples.

The modern water softener is designed to reduce hardness ions and their unpleasant side effects. Special resin beads in the softener mineral tank are used to change hard water into soft water. The surfaces of these beads are covered with sodium ions. As hard water enters the mineral tank and comes into contact with the resin, an exchange of ions takes place as dissolved Calcium and Magnesium ions cling to the resin surface and sodium ions take their place, thus softening the water. This process is called **Ion Exchange**. Over time, the sodium ions used for the exchange process become depleted and must be replenished.

The water softener provides a **Regeneration** process whereby brine solution enters the mineral tank, driving-off the collected hardness ions and replenishes the surface of the resin beads with more sodium ions. This process is automatically initiated by the control valve on the mineral tank. The regeneration process has five basic cycles as follows:

1. **Backwash** - The control valve directs the water flow in a reverse direction through the mineral tank, separating the resin beads and flushing any accumulated particles to a waste drain.
2. **Brine & Rinse** - In the first part of this cycle, the control valve directs brine solution downward through the mineral tank, driving-off collected hardness ions and replenishing the resin beads with sodium ions. The second part of the cycle rinses hardness ions and excess brine from the mineral tank to the waste drain.
3. **Rapid Rinse** - The control valve directs the water flow downward, settling and recompacting the resin bed.
4. **Brine Refill** - The control valve directs fresh water into the salt compartment to create new brine solution for the next scheduled regeneration.
5. **Service** - This is the normal "operating" cycle where hard water enters the mineral tank, comes into contact with the resin beads and exchanges hardness ions for sodium ions - the water then becomes "soft" and ready for use.



PRE-INSTALLATION CHECK LIST

A water test should always be performed in order to determine total water hardness (in gpg) and total dissolved iron (in parts per million - ppm). This is critical for proper equipment selection, sizing and determining the program for regeneration frequency. If heavy concentrations of iron (above 5 ppm), iron coloration, iron bacteria or sediment are present, filtration prior to the softener will most generally be required. Certain states may require a licensed plumber for installation.

NOTE: Flexible water supply connectors and flexible drain line tubing may not be allowed in you locale. Please check with local plumbing code officials prior to installation.



INSTALLATION REQUIREMENTS

-Major System Components-

1. **Brine Tank** - This tank holds the salt that is added to the softener. This salt is dissolved with water to form a brine solution used in the softener regeneration process.
2. **Mineral Tanks**
 - Softener Tank - This tank contains ion exchange resin media. Water flows through the resin tank under pressure to come into contact with the resin for water softening.
 - Filter Tank - This tank contains filter media.
3. **Control Valve** - The valve directs water through the resin tank for water softening and controls the flow of water/brine for the regeneration process.

Unit must be installed at least 10 feet ahead of the inlet to a water heater to prevent damage due to back-up hot water. DO NOT install the unit in an area of direct sunlight or where freezing temperatures may occur!

Locate the unit near an **unswitched**, 120 volt/60 Hz grounded electrical outlet.

Check for distance and proper drain installation (e.g. floor drain, washing machine standpipe). Determine type and size of piping required for filter connection (e.g. copper, galvanized, PVC plastic).

The brine tank drain line is gravity flow and must discharge below the overflow fitting.

The brine overflow is provided as a back-up in the event the safety float shut-off should fail allowing the brine tank to overflow. This drain connection would then carry the excess water to the drain and prevent flooding of the floor. Therefore, no liability will or can be assumed by the manufacturer of the softener should this occur.

NOTE: If household plumbing is galvanized and you intend to make the installation with copper (or vice versa), obtain dielectric unions to prevent dissimilar metal corrosion.

CAUTION: If sweat soldering copper pipe (remember to always use lead free solder and flux), cover yoke and bypass valve with wet rags to prevent heat damage to connections and control valve. If using PVC or plastic pipe, primers and solvent cements specifically recommended for use with potable water are required. Do not "TEE" to the main drain line from the control valve.

NOTE: If installed, all plumbing lines not requiring "soft" water should be connected "upstream" of the softener. (See Typical Installation Diagrams).



TYPICAL SOFTENER SYSTEM ILLUSTRATION

(Incoming Water From Left Side)

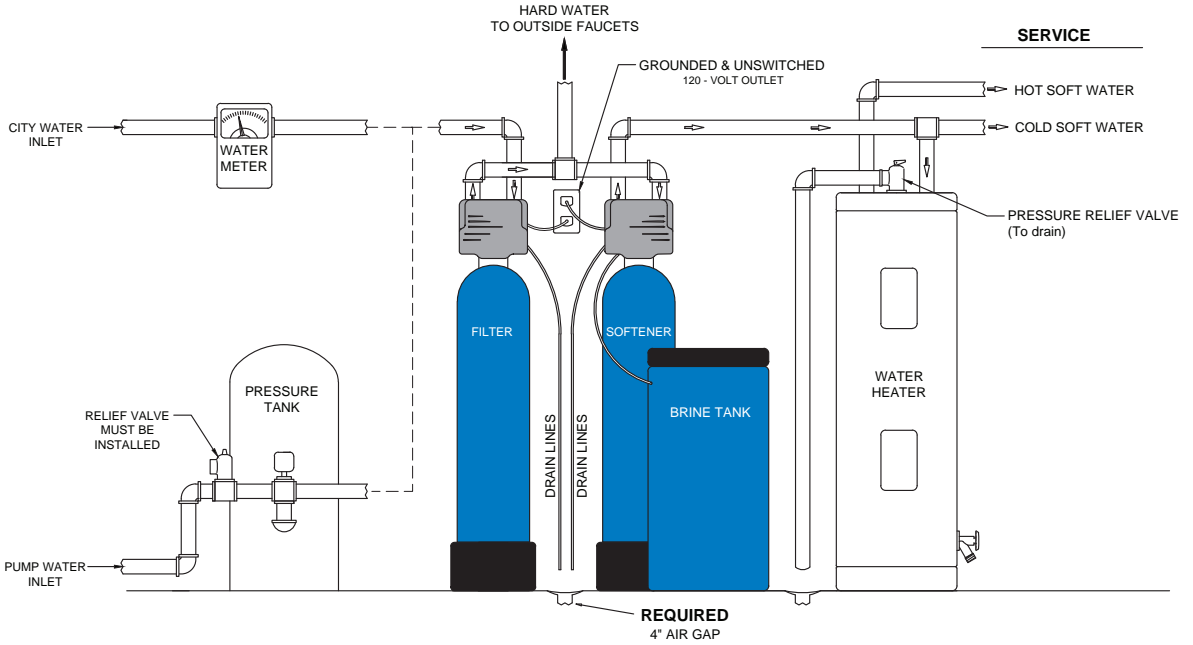



INSTALLATION PROCEDURE

Water Supply Connection and Bypass Valve

To allow for softener servicing, swimming pool filling or lawn sprinkling, a manual Bypass Valve has been included from the factory. The Bypass allows hard water to be manually routed around the softener.

1. Position softener at desired location for installation. (See Installation Diagram).
2. Turn OFF main water supply and OPEN nearest faucet to relieve pressure.
3. Cut main line and install appropriate elbows and extensions. Inlet and outlet connections on the control valve are 3/4" or 1".
4. Rotate Bypass Balve to the BYPASS position (position of lever is at right angle to inlet/outlet piping).
5. Turn the main supply line on to restore water service to the home.
6. OPEN nearest faucet to evacuate air and re-pressurize plumbing lines.
7. Check for leaks.

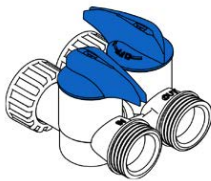

Service

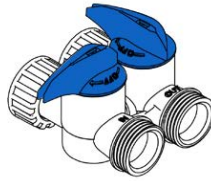

Off

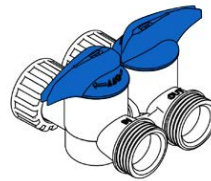

Bypass

CAUTION: Raised arrows located on the sides of control valve body and bypass valve indicate proper direction of water flow. Install inlet and outlet piping in direction of arrows. It is recommended that a vacuum breaker be installed on the inlet plumbing.



DRAIN LINE INSTALLATION

1. The drain line flow control assembly is pre-assembled for your convenience. Should you choose to hard plumb the drain line, please remove the barb fitting. The flow control housing can be removed by removing the clip and pulling straight out on the housing.

NOTE: When re-installing the drain line flow control housing, be sure you hear and feel the O-Ring pop into place before inserting the clip.

2. Install 1/2" I.D. drain line tubing (not included) from hose barb to an open drain. A 4" gap between end of the drain line and the open drain is required to prevent waste water backflow. Keep the drain line as short as possible. An overhead drain line can be used if necessary but should discharge below the control valve. A siphon trap (taped loop) at the outlet of the drain line is advisable to keep the drain line full and to assure correct flow during backwash. Elbows or other fittings must be kept at a bare minimum.

NOTE: Where the drain line is elevated above the control valve or exceeds 20 feet in length, 3/4" I.D. drain line tubing should be used.



BRINE LINE AND OVERFLOW CONNECTION

1. Position brine tank on a smooth, level surface near the softener resin tank. If necessary, the brine tank can be placed at a higher level than the resin tank but never at a lower level.
2. Install one end of 3/8" O.D. by 1/4" I.D. brine line tubing (included with unit) to compression fitting located on left side of control valve.
3. Remove brine tank cover.
4. Remove cap from brine well.
5. Insert opposite end of brine line through outer hole in brine tank.
6. Connect brine line to brine valve located inside brine well. Replace brine well cap.
7. Install 1/2" I.D. drain line tubing (not included) to the overflow fitting on brine tank located just below the brine line.
8. Run the opposite end of brine tank drain line to a suitable drain.



ELECTRICAL CONNECTION

1. Connect the power cord and plug power supply into a 120 volt/60 Hz receptacle.

NOTE: Do not plug into an outlet controlled by a wall switch or pull chain that could inadvertently be turned off.

Electronic Connections

P = POWER SUPPLY

B = POWERED IN BACKWASH STEP ONLY (CYCLE #1)

S = POWERED FOR ENTIRE REGEN. CYCLE



SYSTEM START-UP PROCEDURE

Filling The Brine Tank With Salt

To assure a high level of performance and reliability, a salt manufactured specifically for water softeners must be used. Salt of this grade is virtually free from dirt and other particulates that would eventually cause the softener to malfunction. A pellet type salt is recommended, although any high quality water softener salt (such as solar salt) will suffice. If iron is present in raw water, use of iron inhibiting salt is recommended. The salt level will decrease after each regeneration cycle. Consequently, the salt compartment will need to be checked and replenished periodically.

1. Fill the brine tank or salt compartment with water softener salt as described above. This will be approximately 250 pounds of salt. (150 lbs. for cabinet models.)

WARNING: Do not fill salt above level of the brine well.

2. Replace brine tank lid.

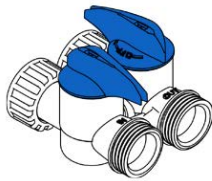
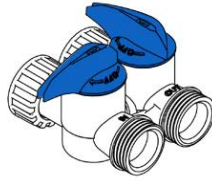
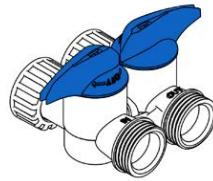
**SYSTEM START-UP PROCEDURE****Service****Off****Bypass**

IMPORTANT NOTE: Tank should be filled with water and media and must have been soaking for at least 1 hour before initial pressurization.

1. After all plumbing and drain line connections have been made, confirm the Bypass Valve is in the BYPASS position.
2. Turn main water supply back on and check for leaks.
3. Cycle the control valve to RAPID RINSE. Once the rapid rinse step is reached, leave the OUTLET side of the Bypass Valve in the CLOSED position. Slowly open the Bypass Valve INLET side to the Service position, allowing air to escape and water to flow down through mineral tank and out the drain line. Let it continue to run for the entire rapid rinse step. There may be colored water or media fines during this initial flow.
4. Once the rapid rinse ends the control valve automatically begins the BRINE REFILL cycle. At this point open a cold, treated watertap. Slowly place Bypass into Service. Let water run to home for several minutes to allow air and any media fines to be released from the lines. Once air is evacuated and water runs clear, close the tap.

NOTE: Any time media (other than very fine mineral on initial startup) is apparent in the service lines, it usually indicates one of the following problems:

- A. The unit is plumbed in backward allowing the media to be carried in the service line.
 - B. The distributor tube inside the tank is not seated inside the valve or is damaged.
5. No further regeneration should be necessary at this time. If left at the default settings, the softener will automatically initiate its regen cycle each night. If desired, these settings can be changed in the main menu, or from the "advanced settings" screen in the Legacy View App.



FINAL CHECK

1. Be certain that the bypass valve is in Service position and main valve is completely on.
2. Check electrical supply to be certain the cord is connected to an uninterrupted 120 volt outlet.
3. Leave this manual with the homeowner.

IMPORTANT NOTE: The plumbing system, piping, pressure tank, hot water tanks, softeners, etc. that have been exposed to iron bearing water may need to be cleaned of the precipitated iron that has been collected in them or iron bleed through may be a problem. We suggest all tanks be drained and flushed thoroughly.



ANNUAL MAINTENANCE

Annual replacement of the seal kit is required in all single tank air systems due to air drying of the seals over time. Potential performance issues will result if this maintenance interval is not performed. Any system problems associated with this required system maintenance not being accomplished will not be covered by the factory warranty.



ADDITIONAL OPERATIONS

Bypass Operations

When the bypass valve is in the **SERVICE** position (position of bypass lever is parallel to the inlet/outlet piping), water is directed through the water softener. Water may be bypassed by turning the lever to the bypass position (position of bypass lever is at right angles to inlet/outlet piping). Water to the home will bypass the softener and be untreated.

You should manually bypass the softener if :

1. The outside lines do not bypass the water softener and water is to be used for lawn sprinkling or other similar uses.
2. Servicing the water softener.
3. A water leak from the water softener is evident.
4. Shock treating water well and piping with chlorine or other disinfectant.

Extra Regeneration -

If soft water demands are unusually heavy, an extra regeneration can be initiated manually.

To Skip A Regeneration -

1. For vacations or extended periods of absence, the power supply can be disconnected from the control valve. It is recommended that the 9-volt battery be removed.
2. Upon return, plug in cord and reset the time of day. Replace 9-volt battery.



GENERAL CARE AND CLEANING

1. Do not place heavy or sharp objects on water softener or cabinet.
2. Use only mild soap and warm water to clean exterior of the unit. Never use harsh, abrasive cleaners.
3. Protect the water softener and drain line from freezing.
4. Reset time for daylight saving time periods.
5. Replace 9-volt battery once a year.
6. Inspect and clean the brine tank when sediment appears in the bottom of the salt compartment.
7. Always keep the brine tank supplied with good quality salt, a type designed for use in water softeners.



For simplified set up and control, please install the Legacy View App on a compatible Bluetooth 4.0+ enabled smartphone or tablet.

1. Download and install the Legacy View App from the Google Play Store, Apple App Store



2. Open the Legacy View App

- You must be within 50' of the device you wish to set up for it to be available on your phone.
- Choose a valve device at any time from the list of available devices to connect to by clicking on it.
- If the valve you want to connect to doesn't show

up, or there is a problem connecting to a device, you can press the "Scan for Devices" button or the Legacy View logo at any time to refresh the list and start the process over.

- If the valve device is a Bluetooth Legacy Enabled (BTLE) valve and it has a password other than the default password, the first time you connect to it the app will ask you to enter the password. After entering it the first time you should not need to enter it again unless it changes.

3. BTLE Valve devices can be updated by the app. When the app is updated from the Google Play Store or the Apple App Store, it may contain an updated firmware program for the valve devices. These updates could contain new features or operational improvements. It is up to the user to allow these updates to be sent to the valve device. Uploading a new program takes approximately 1 minute.

SOFTENER DASHBOARD & SETTINGS SCREENS

NOTE: Consult your dealer before making any changes.

From the Dashboard, all items in **ORANGE** can be changed, while blue fields are informational only.

If you are unsure about the function of the field click the  icon for more information.

Both Landscape and Portrait views are supported.

- In portrait view the navigation menu may be collapsed.
- In landscape view the navigation pane will be shown by default.

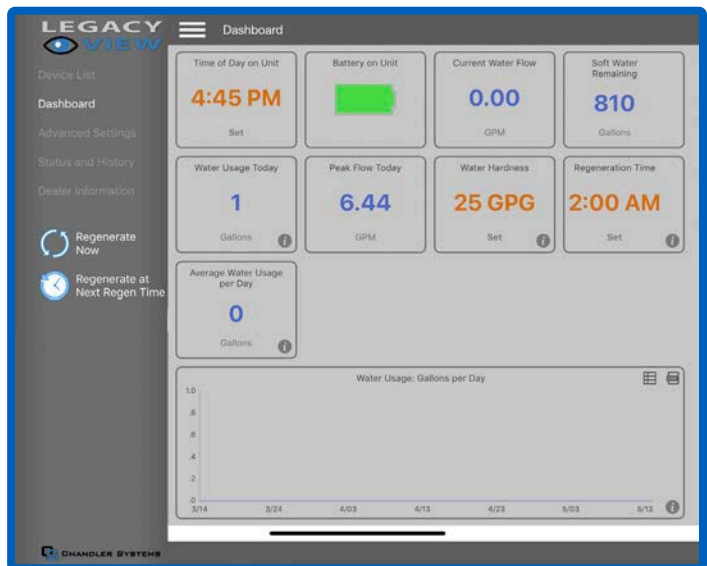

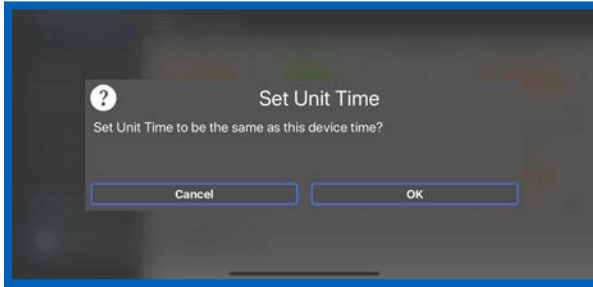

1. Set Unit Time (Press “OK” to set time automatically based on device time).

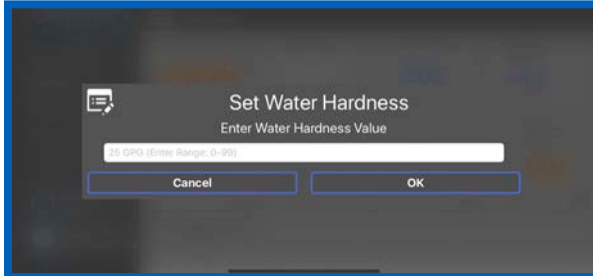

2. Set Water Hardness - This sets the hardness value in grains per gallon.

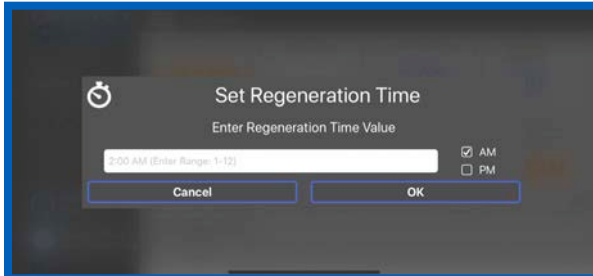

3. Set Regeneration Time - Example: For 2 a.m., just type 2 then press OK.

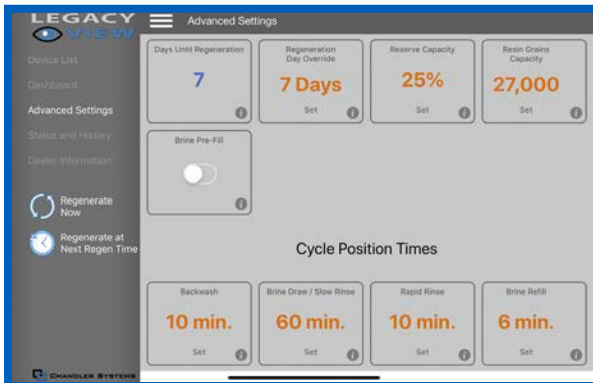

Advanced Settings

NOTE: Consult your dealer before making any changes. We do not recommend changing Advanced Settings unless you have a good understanding of the system operation.

From the Advanced Settings, all items in **ORANGE** with a “set” button can be changed.

FILTER DASHBOARD & SETTINGS SCREENS

NOTE: Consult your dealer before making any changes

From the Dashboard, all items in **ORANGE** can be changed, while blue fields are informational only.

If you are unsure about the function of the field click the **i** icon for more information.

Both Landscape and Portrait views are supported.

- In portrait view the navigation menu may be collapsed.
- In landscape view the navigation pane will be shown by default.

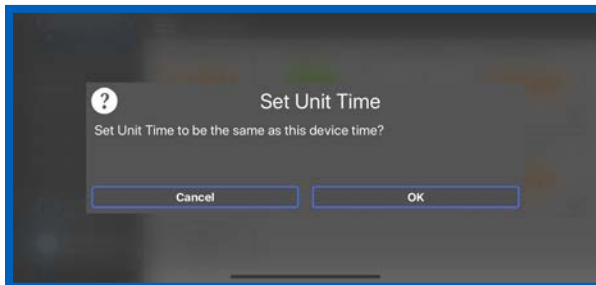
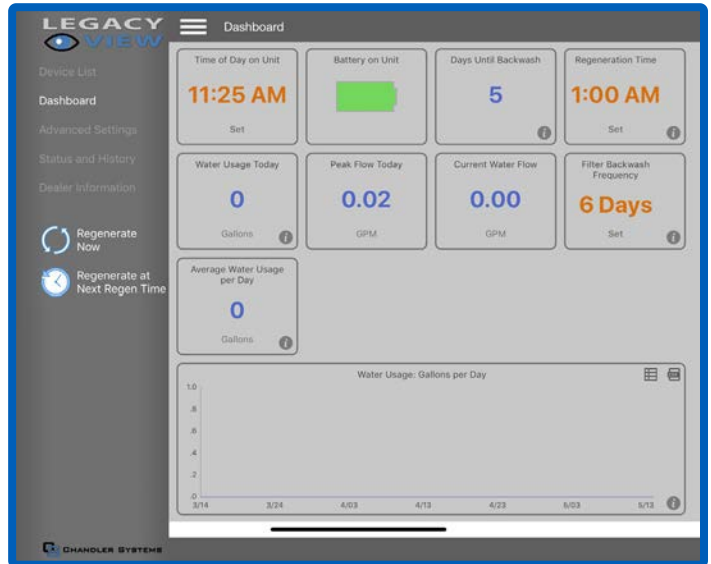

1. Set Unit Time (Press "OK" to set time automatically based on device time).

2. Set Filter Backwash Frequency - This sets the number of days between backwash cycles.



3. Set Regeneration Time - Example: For Midnight, just type 12 then press OK.

NOTE: Do not set to Regen at same time of Softener.

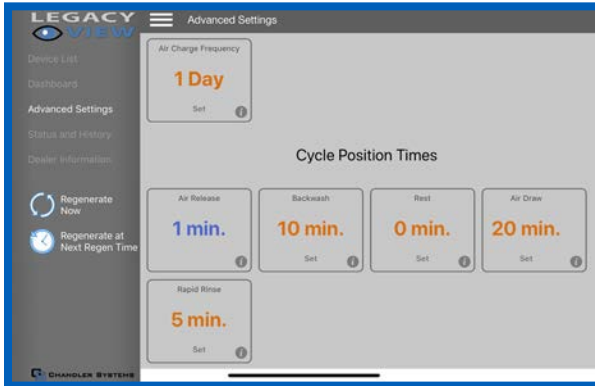
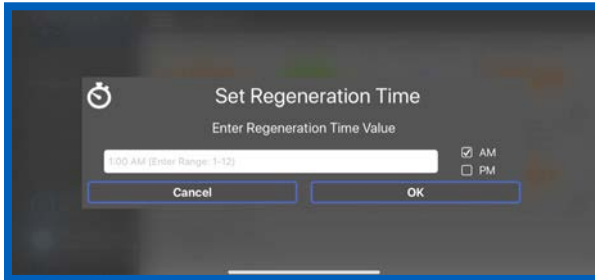

Advanced Settings

NOTE: Consult your dealer before making any changes. We do not recommend changing Advanced Settings unless you have a good understanding of the system operation.

From the Advanced Settings, all items in **ORANGE** with a "set" button can be changed.

Status and History

From the Status and History, all items in **ORANGE** can be reset.

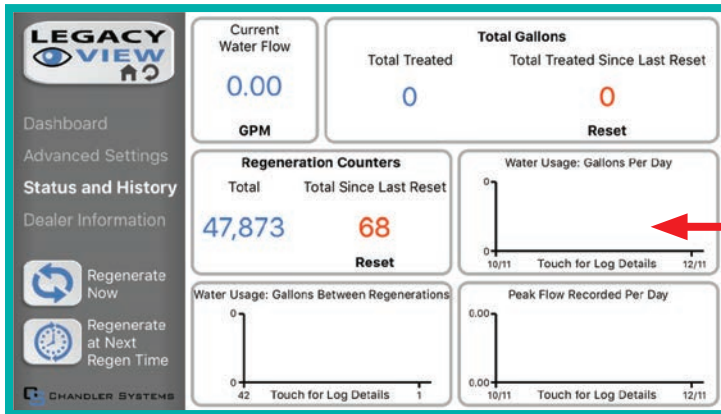

Touch any table to explode a detailed list of the last 60 days.

1. Start a regeneration or backwash cycle:

Option 1:  Click the "Regenerate Unit Now."



If you would like to force the unit into the next cycle step click "Go to Next Regeneration Step".

Option 2:  "Regenerate Unit at Next Regen Time" button.

This will take the system into a backwash cycle at the next regeneration time.

FCC ID: SWPLV-019 or SWPEV-019-BLE

Name of Grantee: CHANDLER SYSTEMS, INC.

Equipment Class: Part 15 Low Power Communication Device Notes: Legacy View Valve

This device complies with part 15 of the FCC Rules. Operation is subject to the following conditions: (1) this device may not cause harmful interference, and (2) this device must accept any interference received, including interference that may cause undesired operation. Changes or modifications not expressly approved by the party responsible for compliance could void the user's authority to operate the equipment. NOTE: This equipment has been tested and found to comply with the limits for a Class B digital device, pursuant to Part 15 of the FCC Rules. These limits are designed to provide reasonable protection against harmful interference in a residential installation. This equipment generates, uses and can radiate radio frequency energy and, if not installed and used in accordance with the instructions, may cause harmful interference to radio communications. However, there is no guarantee that interference will not occur in a particular installation. If this equipment does cause harmful interference to radio or television reception, which can be determined by turning the equipment off and on, the user is encouraged to try to correct the interference by one or more of the following measures:

- Reorient or relocate the receiving antenna.
- Increase the separation between the equipment and receiver.
- Connect the equipment into an outlet on a circuit different from that to which the receiver is connected.
- Consult the dealer or an experienced radio/TV technician for help.

Main Menu

A digital display showing the time 12:00 in red digits on a black background.A blue button with a black circle on the left and the text MENU/ENTER in white.A blue button with a black circle on the left and the text SET/CHANGE in white.

1. To enter Main Menu, press the **Menu/Enter** button. (Time of Day will flash)
2. To set the **Time of Day**, press the **Set/Change** button.
(First digit will flash) **Example: (12:00)**
 - To change digit value, press the **Set/Change** button.
 - To accept the digit value, press the **Menu/Enter** button.
 - Next digit will flash to begin setting.
 - Once the last digit display is accepted, all digits will flash.
3. To set **A.M.** or **P.M.**, press the **Menu/Enter** button.
 - To change digit value, press the **Set/Change** button. **Example: (A)**
 - To accept the digit value, press the **Menu/Enter** button.
 - Once A.M. or P.M. is accepted, the next menu item will flash.

For Softener Valve

4. To set Hardness an **(H)** will appear to enter Compensated Hardness in grains per gallon (gpg).
 - Default setting is 25 gpg. **Example: (H-25)**
5. To Exit Main Menu, press the **Menu/Enter** button.

NOTE: If no buttons are pressed for 60 seconds, the Main Menu will be exited automatically.

For Filter Valve

4. To set the Number of Days between Backwash Cycles **(A)**, press the **Set/Change** button. - Repeat instructions from step (2). **Example: (A-06)**

NOTES:

- 1) Maximum value is 29.
- 2) If value set to 0, Automatic Backwash will never occur.
- 3) Default setting is 6 days for filters.

5. To Exit Main Menu, press the **Menu/Enter** button.

NOTE: If no buttons are pressed for 60 seconds, the Main Menu will be exited automatically.

Normal Operation

1. Home Display

Metered Softeners will alternate between time of day and gallons remaining until next regeneration.

- The meter will count down to zero (0000) and then regenerate at the scheduled time set.

Filters alternate between time of day and number of days until the next backwash.

- Days remaining until the next backwash will count down from the entered value until it reaches 1 day remaining.

- A backwash cycle will then be initiated at the next designated regeneration time.

2. Battery Back-Up (Uses a standard 9-volt alkaline battery. Not included.)

Features of Battery Back-Up:

- During power failures, the battery will maintain the time of day as long as the battery has power. The display is turned off to conserve battery power during this time. To confirm that the battery is working, press either button and the display will turn on for five (5) seconds.
- If power failure occurs while system is regenerating, the system will motor to a shut off position to prevent constant flow to drain. After power is restored, the system will return and finish the cycle where it left off prior to the power interruption.
- When used without battery back-up, during a power failure, the unit stops at its current point in the regeneration position and then restarts at that point when the power is restored. The time will be offset by the increment of time the unit was without power, so it is necessary to reset the time of day on the unit. No other system settings will be affected.

Starting Extra Regeneration Cycle

1. To Start **Delayed Extra Cycle:** Example: [1]

- If Gallons Remaining Until Next Regeneration does not read '0000', press and hold the **Set/Change** button for 3 seconds until the display reads '0000.'
- Regeneration cycle will initiate at the next designated regeneration time.

2. To start **Immediate Extra Cycle:** First complete above step and with Days Remaining Until Next Regeneration at '0000.'

- Press and hold the **Set/Change** button.
- After 3 seconds, the regeneration cycle will begin.

3. To **Fast Cycle** thru regeneration: First complete above 2 steps.

Press and hold the **Set/Change** button for 3 seconds to advance to the next cycle step.

NOTE: Fast Cycle is not necessary unless desired to manually step through each cycle step. (Repeat until valve returns to the home display).

Regeneration Cycle

Softeners	Default Cycle Step Times	Minutes
Step 1	Backwash	10
Step 2	Brine & Rinse	60
Step 3	Rapid Rinse	10
Step 4	Brine Refill	9lbs/cu ft

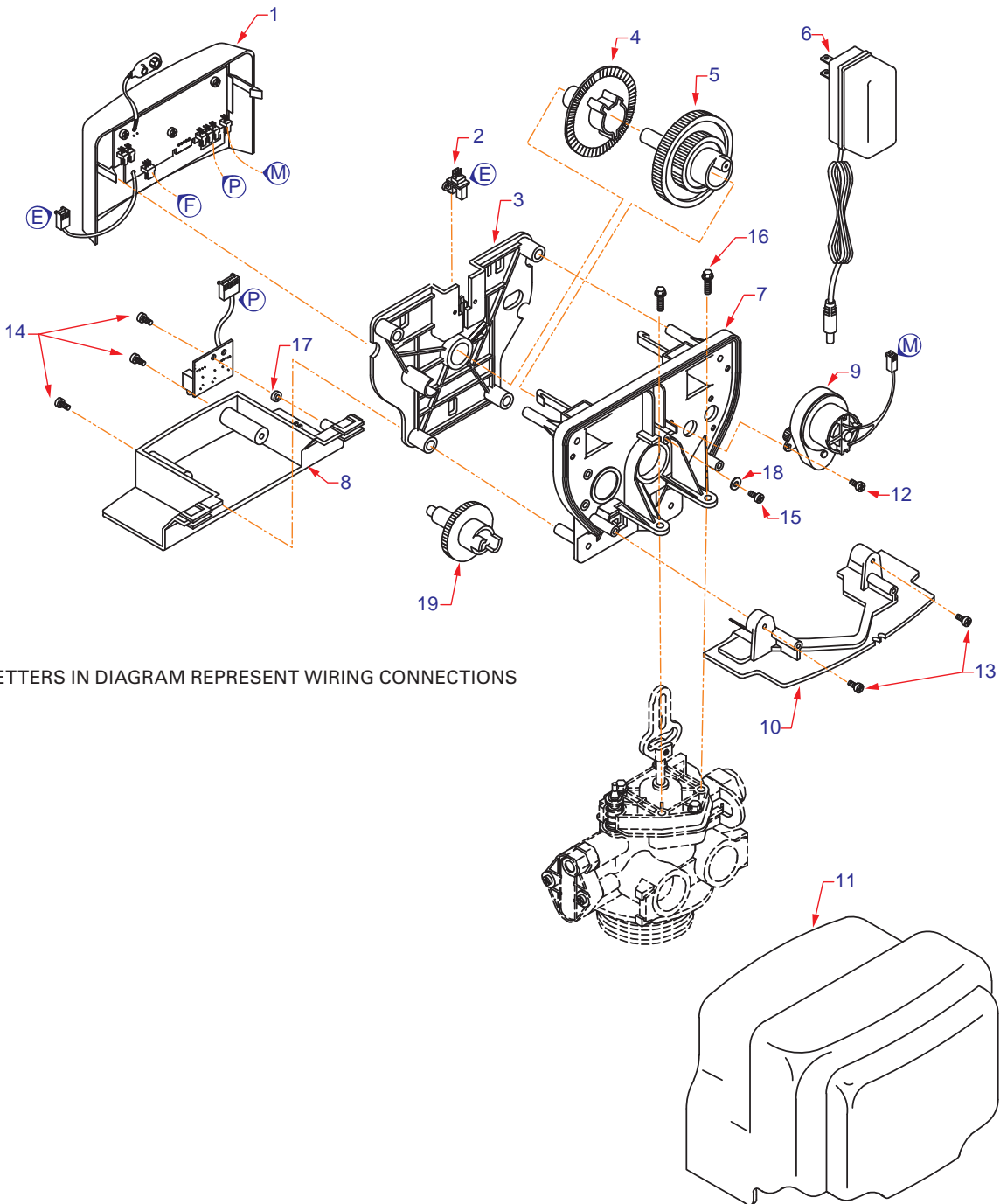

LETTERS IN DIAGRAM REPRESENT WIRING CONNECTIONS

Control Valve Parts Listing

Ref	Description	Part#	Qty	Ref	Description	Part#	Qty
0	Powerhead Assembly	22003N100	1	10	Lower Back Base for Cover 20111X003		1
1	Circuit Board Assembly	CS-BOARD ENCLOSURE	1	11	Slide Cover	20111X017	1
2	Encoder	20001X124	1	12	Motor Screw	SC2	2
3	Front Plate	20001X004	1	13	Screw	SC9	2
4	Encoder Wheel	20001X007	1	14	Screw	SC10	3
5	Main Gear	21001X120	1	15	Piston Screw	20001X003	1
6	Power Supply	CS-TRANS	1	16	Valve Hex Screw	20001X001	2
7	Back Plate	20001X005	1	17	Circuit Board Washer	20111X014	1
8	Lower Front Base for Cover 20111X002		1	18	Piston Washer	20001X002	1
9	Motor	20016X006	1	19	Brine Cam	20001X122	1

Bypass Assembly

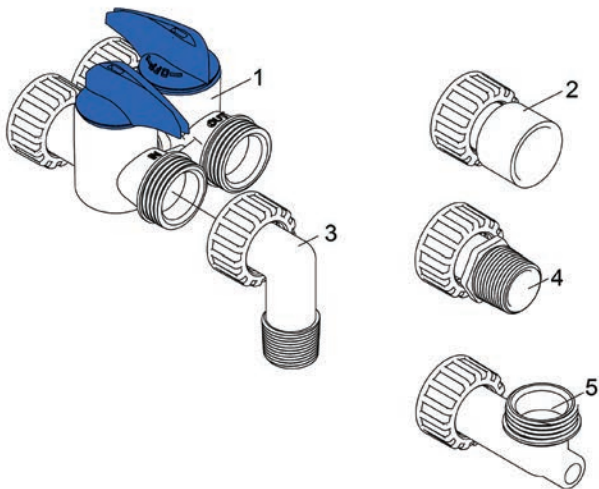

Ref	Description	Part#
1	Bypass	CS-BYPASS
2	1" Female Straight Slip (set of 2)	CS-10S-PVC-SLIP
3	1" NPT Elbow (set of 2)	CS-10E-PVC-MIPT
4	1" NPT Straight (set of 2)	CS-10S-PVC-MIPT
5a	Elbow, Vertical Adapter Blank (set of 2)	CS-10-90-PVC-BVA
5b	Elbow, Vertical Adapter 1/4" NPT Tapped (set of 2)	20017X294
	3/4" Male NPT Straight (set of 2)	CS-07S-PVC-MIPT
	3/4" Brass Sharkbite Straight (set of 2)	CS-07-SHARK

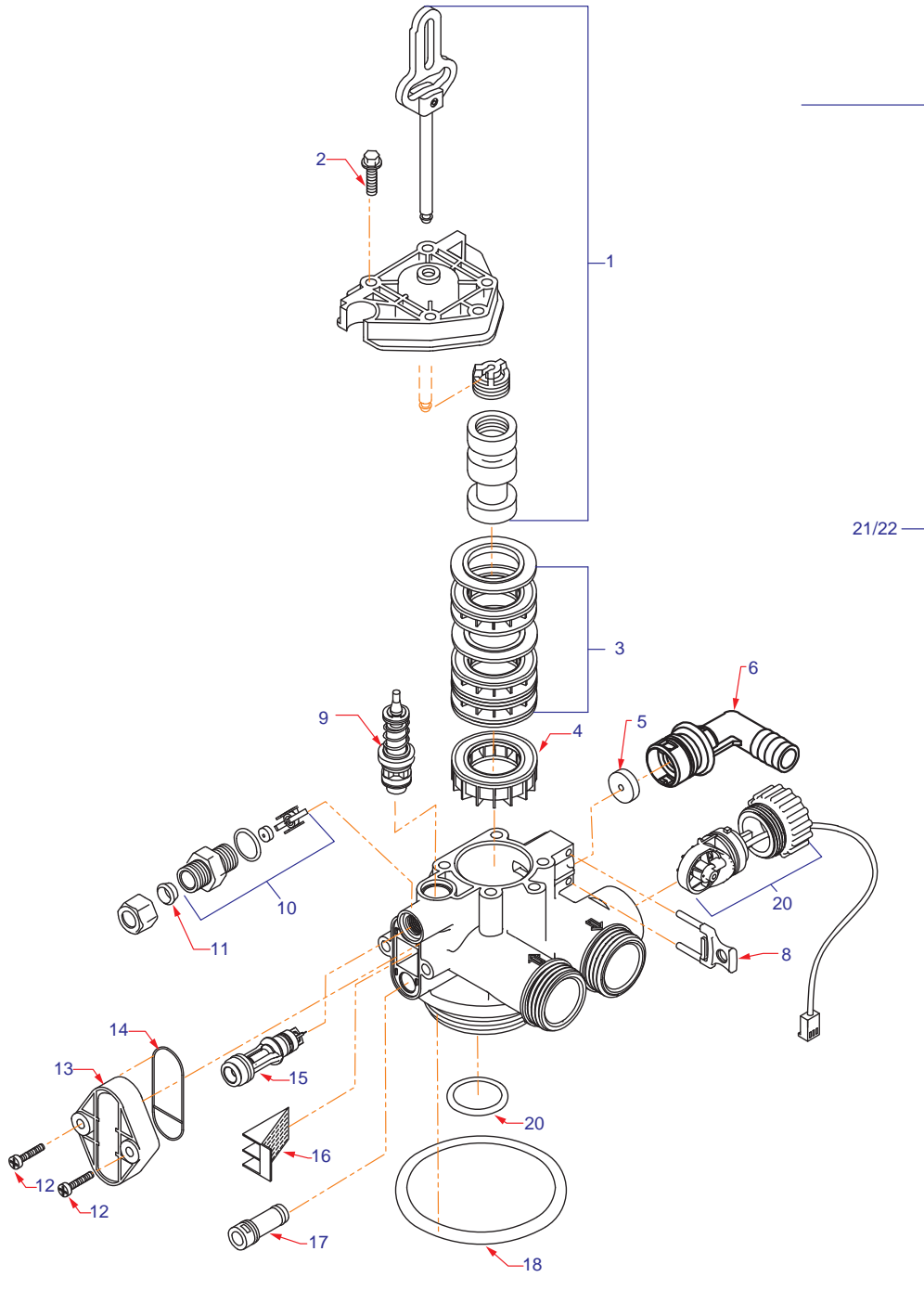

Ref	Description	Part#	Qty
1	<i>Piston Assembly</i>	<i>CS-PISTON</i>	<i>1</i>
2	<i>10-24 X 13/16 Hex Head</i>	<i>20001X001</i>	<i>5</i>
3	<i>Seal and Spacer Kit</i>	<i>CS-SEALS</i>	<i>1</i>
4	<i>Bottom Spacer</i>	<i>N/A</i>	<i>1</i>
5	<i>DLFC 2.4 Button</i>	<i>20251X268</i>	<i>1</i>
5	<i>DLFC 3.5 Button</i>	<i>20251X270</i>	<i>1</i>
6	<i>Drain Line Flow Control Housing</i>	<i>20017X268</i>	<i>1</i>
8	<i>DLFC Clip</i>	<i>20017X214</i>	<i>1</i>
9	<i>Brine Valve</i>	<i>20561X225</i>	<i>1</i>
10	<i>Brine Line Flow Control Assy.</i>	<i>20001X228</i>	<i>1</i>
11	<i>Brine Line Ferrule</i>	<i>20251X305</i>	<i>1</i>
12	<i>10-24 X 1 Hex Screw</i>	<i>20001X226</i>	<i>2</i>
13	<i>Injector Cap</i>	<i>20001X223</i>	<i>1</i>
14	<i>Injector Cap Seal</i>	<i>20001X224</i>	<i>1</i>
15	<i>Injector w/ Check Ball - Blue</i>	<i>20017X220</i>	<i>1</i>
16	<i>Injector Screen</i>	<i>20001X222</i>	<i>1</i>
17	<i>Injector Plug</i>	<i>20001X217</i>	<i>2</i>
18	<i>Tank O-Ring</i>	<i>20561X205</i>	<i>1</i>
19	<i>Distributor Tube O-Ring</i>	<i>20561X204</i>	<i>1</i>
20	<i>Flow Meter</i>	<i>CS-METER</i>	<i>1</i>
21/22	<i>Valve Body Complete</i>	<i>VH1-B-D15</i>	<i>1</i>



SYSTEM SERVICING PROCEDURE

A. General Preliminary Instructions

PERFORM BEFORE ALL SERVICING OPERATIONS

1. Turn off water supply to conditioner.
 - If the conditioner installation has a “three valve” bypass system, first open the valve in the bypass line, then close the valves at the conditioner inlet and outlet.
 - If the conditioner has an integral bypass valve, put it in the bypass position.
 - If there is only a shut off valve near the conditioner inlet, close it.
2. Remove cover and relieve water pressure in the conditioner by stepping the control into the backwash position momentarily. Return the control to the service position.
3. Unplug electrical cord from outlet.

B. To Replace Powerhead

1. Remove the control valve cover and disconnect the power supply.
2. Disconnect the meter cable from circuit board and feed back through control (if existing meter is being re-used).
3. Remove lower back base screws and detach lower back base.
4. Remove screw and washer at drive yoke. Remove powerhead mounting screws. The entire powerhead assembly will now lift off easily.
5. Put new powerhead on top of the valve. Be sure the drive pin on main gear engages slot in drive yoke (wide side of drive yoke upright must face to the left away from the motor).
6. Replace powerhead mounting screws. Replace screw and washer at drive yoke.
7. Reattach lower back base.
7. Reconnect meter signal, wire and power supply.
8. Reinstall cover.

C. To Replace Piston Assembly

1. Follow steps **A1 - A3**.
2. Disconnect the meter signal wire from the circuit board.
3. Remove lower back base screws and detach lower back base.
4. Remove screw and washer at piston drive yoke. Remove powerhead mounting screws. The entire powerhead assembly will now lift off easily.
5. Remove piston retaining plate screws.
6. Pull upward on end of piston yoke until assembly is out of valve.
7. Inspect the inside of the valve to make sure that there is no foreign matter that would interfere with the valve operation.
8. Install new seals and spacers.
9. Take new piston assembly and push piston into valve by means of the end plug. Twist drive yoke carefully in a clockwise direction to properly align it with drive gear. Reinstall piston retaining plate screws.
10. Follow steps **B5 - B9**.

D. To Replace Seals and Spacers

1. Follow steps **A1 - A3**.
2. Disconnect the meter signal wire from the circuit board.
3. Remove screw and washer at piston drive yoke. Remove powerhead mounting screws. The entire powerhead assembly will now lift off easily. Remove piston retaining plate screws.
4. Pull upward on end of piston rod yoke until assembly is out of valve. Remove seals and spacers. (Note: Special end spacer must be reused).
5. Lubricate new seals with silicone lubricant included in the seal and spacer kit. Make sure the special end spacer is properly seated in the valve body. Install new seals and spacers individually, pressing around the outer edge of each seal to make sure it is seated. (When all seals and spacers are seated properly, you will have a 1/4" of space between the top seal and the top of the valve body).
6. Follow Steps **C9 - C10**.

E. To Service Injector and Screen

1. Follow steps **A1 - A2**.
2. Unscrew injector cover screws and remove injector cover.
3. Remove injector screen and clean or replace.
4. Remove injector and clean or replace.
5. Apply silicone lubricant to injector seal and replace cover and screws.

F. To Replace Meter

1. Follow steps **A1 - A3**.
2. Unplug meter cable from front of circuit board.
3. Unscrew meter assembly nut from valve body.
4. Remove meter from valve body and clean or replace as necessary.
5. Reinstall meter, nut and cable.

G. To replace Brine Valve

1. Follow steps **A1 - A3**.
2. Inspect brine valve cavity in valve body and remove any foreign matter that would interfere with brine valve operation.
3. Apply silicone lubricant to brine valve O rings and push the new brine valve into the valve body.
4. Continue following Piston Replacement instructions to reinstall piston and powerhead.

Symptom	Problem Cause	Correction
1. Softener Fails to Regenerate Automatically	Power supply plugged into intermittent or dead power source	Connect to constant power source
	Disconnected meter cable	Reconnect cable
	Improper control valve programming	Reset program settings
	Defective power supply	Replace power supply
	Meter is dirty or defective	Clean or replace meter assembly
	Defective drive motor	Replace motor
2. Regeneration at Wrong Time	Time of day improperly set due to power failure	Reset time of day programming and install 9-volt battery
	Regeneration time set improperly	Reset regeneration time programming
3. Loss of Capacity	Increased raw water hardness	Increase hardness setting or decrease days between regeneration
	Brine concentration and or/quantity	Keep brine tank full of salt at all times Clean it yearly Salt may be bridged If using a salt grid plate, ensure refill water is over it.
	Resin fouling	Call dealer Find out how to confirm it Clean the resin and prevent future fouling
	Poor distribution, channeling (uneven bed surface)	Call dealer Check backwash flow Regenerate more frequently
	Internal valve leak	Call dealer Replace spacers, seals and/or piston
	Resin age	Call dealer Check for resin oxidation caused by chlorine Mushy resin
	Resin loss	Call dealer Check for correct bed depth Broken distributor tube Air or gas in bed: well gas eliminator Loose brine line
4. Poor Water Quality	Check items listed in #1, #2, and #3	
	Bypass valve open	Close bypass valve
	Channeling	Check for too slow or high service flow Check for media fouling

Symptom	Problem Cause	Correction
5. High Salt Usage	High salt setting	Lower brine tank refill time
	Excessive water in brine tank	See symptom #7
	Constant flow through the unit	Indicates plumbing leak (e.g. toilet tank)
	Regenerating too frequently	Lower hardness setting or increase days between regeneration
6. Loss of Water Pressure	Plumbed in backward	Re-plumb the system properly
	Internal leak in unit	Call dealer
7. Excessive Water in Brine Tank and/or Salty Water to Service	Plugged drain line or drain line control	Check flow to drain Clean drain line flow control button
	Dirty or damaged brine valve	Clean or replace brine valve
	Plugged injector or screen	Clean or replace injector screen
	Low inlet pressure Increase pressure to allow injector to	Increase pressure to allow injector to perform properly, (20 psi minimum)
	Excessive brine refill cycle time	Lower brine refill time
8. Softener Fails to Use Salt	Check items listed in #1	
	Improper control valve programming	Check and reset programming
	Plugged/restricted drain line	Clean drain line and/or flow control button
	Injector and/or screen is plugged	Clean or replace injector and screen
	No water in brine tank	Check for restriction in BLFC Ensure safety float is not stuck Check brine tank for leaks
	Water pressure is too low	Line pressure must be at least 20 psi
	Brine line injects air during brine draw	Check brine line connections for air leaks
Internal control leak	Call dealer Check piston, seals and spacers for scratches and dents	
9. Continuous Flow to Drain	Foreign material in control piston and seals	Call dealer Clean valve and replace piston and seals
	Internal control leak	Same as above
	Valve jammed in backwash, brine or rapid rinse position	Same as above
	Motor stopped or jammed	Check for jammed piston Replace piston and seals Replace motor if motor is unresponsive

Control Valve Error Code Diagnosis - Under normal operating conditions, when your control valve is in the “in service” position, the display should alternate between the current time of day and the number of days remaining (for filters and time clock softeners) or gallons remaining (for metered softeners) until the next regeneration. This is the “home display.” If the valve is currently going through a regeneration cycle, the display will show the cycle step on the left side of the display and the number of minutes remaining in that step on the right side of the display. If any other information is being displayed, then the valve is informing you of an issue. There are five error codes which could indicate an issue with the control valve. When an error is being displayed, the valve will be in a stopped position, and the buttons will not respond to being pressed. Even if the cause of the error code is corrected, the error code will not clear until the power supply has been disconnected and reconnected (this will be referred to as “cycling” the power). All error codes are displayed as the letters “Err” followed by a flashing number 2-6:

Error 2 - Valve is searching for homing slot. - Allow valve to continue running. If the homing slot is found, the valve will return to the home display, otherwise, another error code will appear.

Error 3 - No encoder slots are being seen. - This occurs when the motor is running, but the encoder is not seeing any of the slots in the encoder wheel. This can happen if the encoder has been disconnected, but most commonly occurs when debris in the valve body has stopped the piston, causing the encoder wheel to be unable to turn.

1. Check encoder connection. If the encoder is plugged in and snapped into place, skip to step #2. If encoder is disconnected, reconnect it and cycle power to clear the error.
2. Disconnect powerhead from valve body. Cycle power to clear the error code. Manually cycle the powerhead through the regeneration cycle steps to verify that the motor can cycle properly while the powerhead is disconnected from the valve body. If the Error 3 does not reappear, skip to step #3. If the error 3 does reappear, order a board & motor kit to replace the circuit board & motor.
3. Remove piston and seals from the valve body and inspect valve body for debris. Replace the seal & spacer kit. Inspect piston and replace piston if Teflon coating is worn

Error 4 - Unable to find homing slot. - Check encoder wheel for debris.

2. Cycle power. Valve should either find home or go to a different error code. If Error 4 returns, replace powerhead assembly.

Error 5 - Motor overload. - This occurs when the motor current is too high. This could be caused by an issue with the motor itself, but is typically caused by friction in the valve body.

1. Disconnect powerhead from valve body and cycle power to clear the error code.
2. If the Error 5 returns, replace the motor. Otherwise, manually cycle the powerhead through the regeneration cycle steps to verify that the motor can cycle properly while the powerhead is disconnected from the valve body. Either way, proceed to the next step.
3. Remove piston and seals from the valve body and inspect valve body for debris. Replace the seal & spacer kit. Inspect piston and replace piston if Teflon coating is worn.

Error 6 - No motor current. - This typically occurs if the motor cable has come unplugged from the circuit board. Check that the motor cable is plugged into the circuit board and attached to the motor. If this is not the issue, the motor or circuit board may need to be re- placed.

No Display - If your display is blank, there is no power going to the circuit board due to one of the following factors:

- The electrical outlet is not powered or is switched off.
- The power cable has come unplugged from the circuit board.
- The power supply has come unplugged from your electrical outlet.
- The power supply has come unplugged from the control valve.
- The power supply is not working.

Water Conditioner Limited Warranty

We warrant this water conditioner when installed according to factory recommendations, to be free from defects in materials and workmanship as follows:

Limited Warranty

This water conditioner unit is assembled from the finest industry components available. Each individual component used in the assembly of our equipment is covered by the original equipment manufacturer's warranty. All components, except those specifically listed below, are warranted for a period of one (1) year from date of installation to the original purchaser to be free of defects in materials and workmanship subject to the manufacturer's conditions and/or the conditions shown below.

Mineral Tanks

The fiberglass, polyglass or composite mineral tanks used in the assembly of this unit are warranted to be free of defects in materials and workmanship for a period of ten (10) years on 6" - 13" size tanks, and five (5) years on 14" and larger size tanks used for softener/filtration applications, subject to the original manufacturer's conditions and/or the conditions shown below. Warranty does not cover sandblasting of tank caused by faulty distribution systems, fractures caused by external impact and exposure to vacuum.

Control Valves

The control valve (if used in the assembly of the unit) is warranted to be free of defects in materials and workmanship for a period of seven (7) years subject to the original manufacturer's conditions and/or the additional conditions shown below.

Conditions

1. This warranty only covers water conditioners installed for residential use. Water conditioners installed for commercial or industrial applications are guaranteed for one (1) year from the date of installation.
2. Installation must be made in accordance with legal or local codes and manufacturer's recommendations.
3. Failure must not result from misuse, alteration, fire, lightning, power surges or neglect.
4. Water pressure must not exceed 100 p.s.i. and water temperature must not exceed 100 degrees.
5. Damage or failure of a Product or Part caused by friction, wear, chemical attack, or debris build-up on wear parts. "Wear Parts" include, but not limited to: pistons, piston rods, seals spacers, end cap quad rings and brine valve on all piston operated valves, as well as valve disk flappers on Autotrol valves, and parts requiring replacement under recommended maintenance procedures, such as filter housing o-rings and gaskets.

Subject to the above terms and conditions we will replace and/or repair, at our option, any parts of the water conditioner found defective in materials and workmanship. Defective parts must be returned, freight pre-paid, by your dealer, who will supply a replacement furnished by the company. This warranty does not cover labor, shipping charges, damages caused by delays of consequential damages or other causes beyond our control.

This warranty is to the original purchaser and is not transferable after the third year to any subsequent owner(s).

No other guarantee or warranty, expressed or implied, is applicable to our product. No repair or replacement made under the terms of the warranty shall extend this warranty.

Product	Warranty
<i>Residential Mineral Tank</i>	<i>10 Years</i>
<i>Connected Series Control Valves</i>	<i>7 Years</i>
<i>Other Accessories and Parts</i>	<i>1 Years</i>