



M-Adapter Plate Kit (Outboard Motor Application)



Product Quality Assurance

JL Marine Systems, Inc. assures that this product is made with the finest quality materials and is free from manufacturer defects.

Please inspect this product immediately prior to installation. If defects are apparent, please contact JL Marine Systems, Inc. Warranty Department at 813-689-9932 immediately.

Please read all instructions carefully for proper product installation. JL Marine Systems, Inc. is not responsible for improper installation of product.

Hardware:

- A** (1) M-Adapter Plate
- B** (1) Shim
- C** (4) 3/8" x 1.75" Bolts
- D** (4) 3/8" x 7/8" Neo-bond Washers
- E** (4) 3/8" Heavy Thunder Washers
- F** (4) 3/8" Lock Nuts

Installation Tools:

- 9/16" Socket with Ratchet
- 9/16" Wrench
- 3/4" Socket with Ratchet

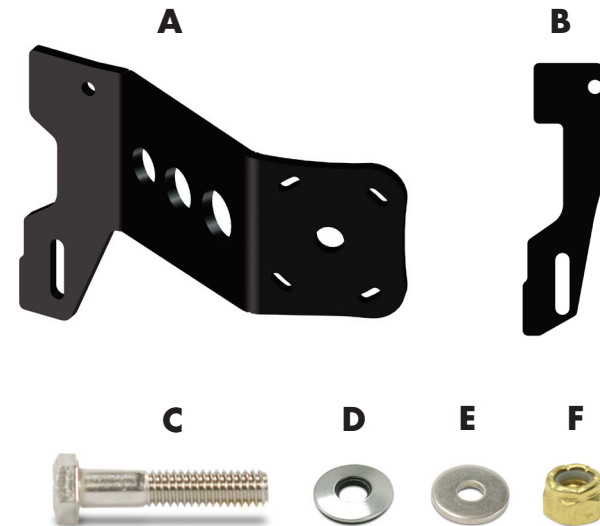

Note: JL Marine Systems, Inc. recommends that adapter plates be installed by an authorized Power-Pole® dealer. To find a dealer near you go to power-pole.com

Installation Instructions

Step 1 The outboard motor needs to be supported in the safest possible way.

Step 2 IMPORTANT: Identify if your adapter plate is for Port or Starboard installation by looking for a "P" or "S" at the end of the part number that appears on the adapter plate.

On the side that the adapter plate (A) will be installed, completely remove the bolts that attach the outboard motor to the transom **Fig A-1** or outboard motor to jack plate **Fig A-2** Next, loosen the bolts on the opposite side about 3/4 of an inch where shim (B) will be installed later.

Mounting adapter plate between transom and outboard motor

Example:
Port side
adapter plate
installation
diagram

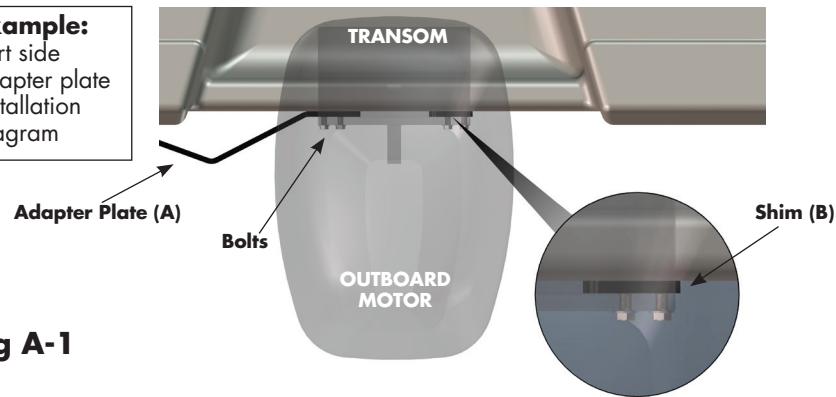

Fig A-1

Mounting adapter plate between jack plate and outboard motor

Example:
Port side
adapter plate
installation
diagram

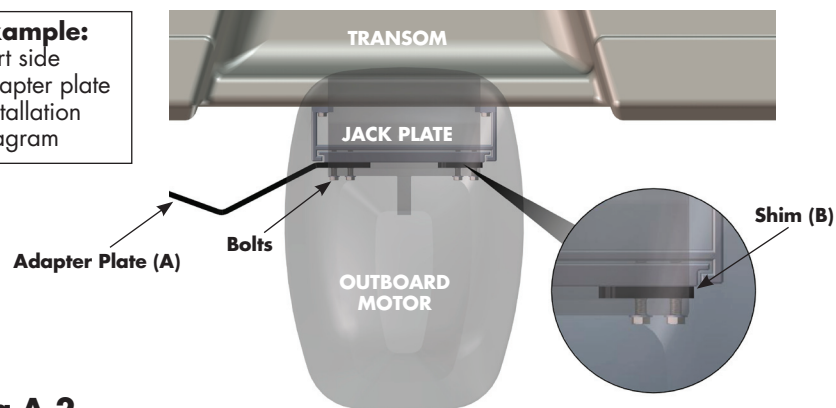

Fig A-2

Note: If your jack plate is a Bob's Machine Jack Plate you will need to purchase a Spacer Kit 3/4".

For Technical Support Call 813-689-9932 opt 2

Installation Instructions - continued

Step 3 Install the adapter plate (A) on the side where bolts have been completely removed.

Note: Be sure not to fully tighten bolts until shim (B) has been installed on the opposite side.

Next, finish removing previously loosened bolts and install shim (B). Finish by tightening all jack plate mounting bolts back to the original manufacturer's torque specifications.

Step 4 Now you're ready to install the Power-Pole shallow water anchor stern bracket to the adapter plate:

Place neo-bond washer (D) onto each bolt (C) with neo-bond side facing the thread end of bolts (C).

Note: The neo-bond washer protects the powder coated marine finish on the stern bracket.

Now insert the dressed bolts (C) through the Power-Pole stern bracket, adapter plate (A), heavy thunder washer (E) and then thread lock nuts (F) onto each bolt and tighten to 120 inch pounds / 10 foot pounds of torque **Fig A-3.**

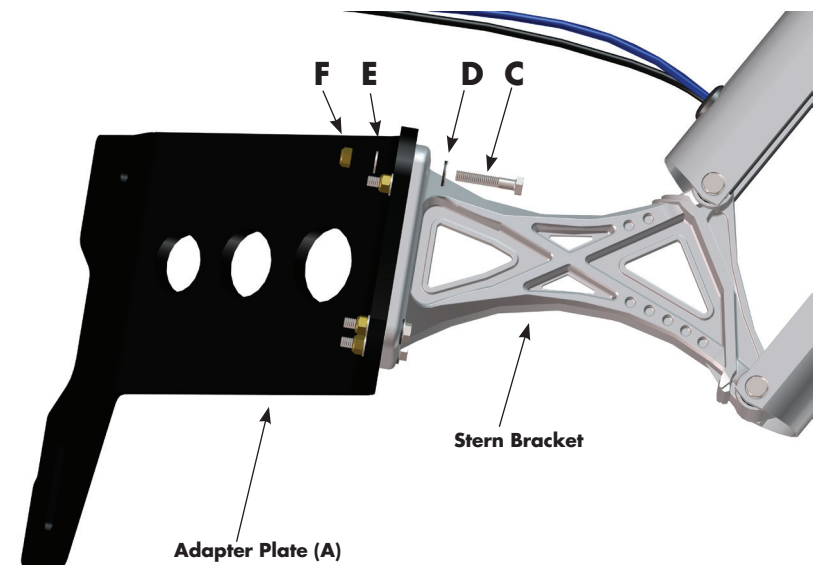

Fig A-3

For Technical Support Call 813-689-9932 opt 2