

RTO

SafeSite® L-810 Red LED Side Lights Class 1, Div 2

Complies with the following specifications:

Class 1, Div 2 Groups B, C, D | T3C temperature rating | IP66 | UL 1598
NEMA 4X copper free aluminum enclosure | UL 844 | FAA L-810



Application

The RTO Series obstruction light utilizes a unique optical, electrical and mechanical design. The RTO Series is the most universal, compact and efficient obstruction light in the world. ETL Certified to the FAA requirements, the RTO Series fixture is also ICAO and Transport Canada compliant. Also available as a single fixture for direct replacement of incandescent lamp/lens technology.

Operating Conditions

The RTO Series is designed to withstand the dynamic conditions experienced in the most severe environments around the world. It has been tested in temperatures ranging from -40° to +55° Celcius, direct sunlight, wind-blown rain, wind in excess of 150 mph, high humidity, salt and fog.

Specifications

Operating Voltage	120 to 240 VAC; 48VDC
Operating Temperature	-40°F to +131°F (-40°C to +55°C)
Unit Weight	1.25 lbs (0.56kg) (retro unit) 2.00 lbs (0.91 kg) (single unit) 4.60 lbs (2.09 kg) (double unit)

Materials / Finish:

- Cast Aluminum base and housing
- Aviation Red UV resistant polycarbonate dome

Key Features

- Available as a single, double or retro-fit unit.
- Available in 120 - 240 VAC; and 12 - 48 VDC
- Unique optical design (patent pending)
- Advanced high-flux LED technology
- Estimated service life 12-15 years
- Weather/corrosion resistant lamp assembly and housing
- Self-contained wiring compartment eliminates additional boxes
- Threaded 1" and ¾" bottom hub for mounting
- Can be operated steady or flashed
- Uses 95% less energy than incandescent
- 5 year warranty
- Resistant to shock and vibration
- IP65 / IP66 / NEMA 4X

Mechanical Dimensions

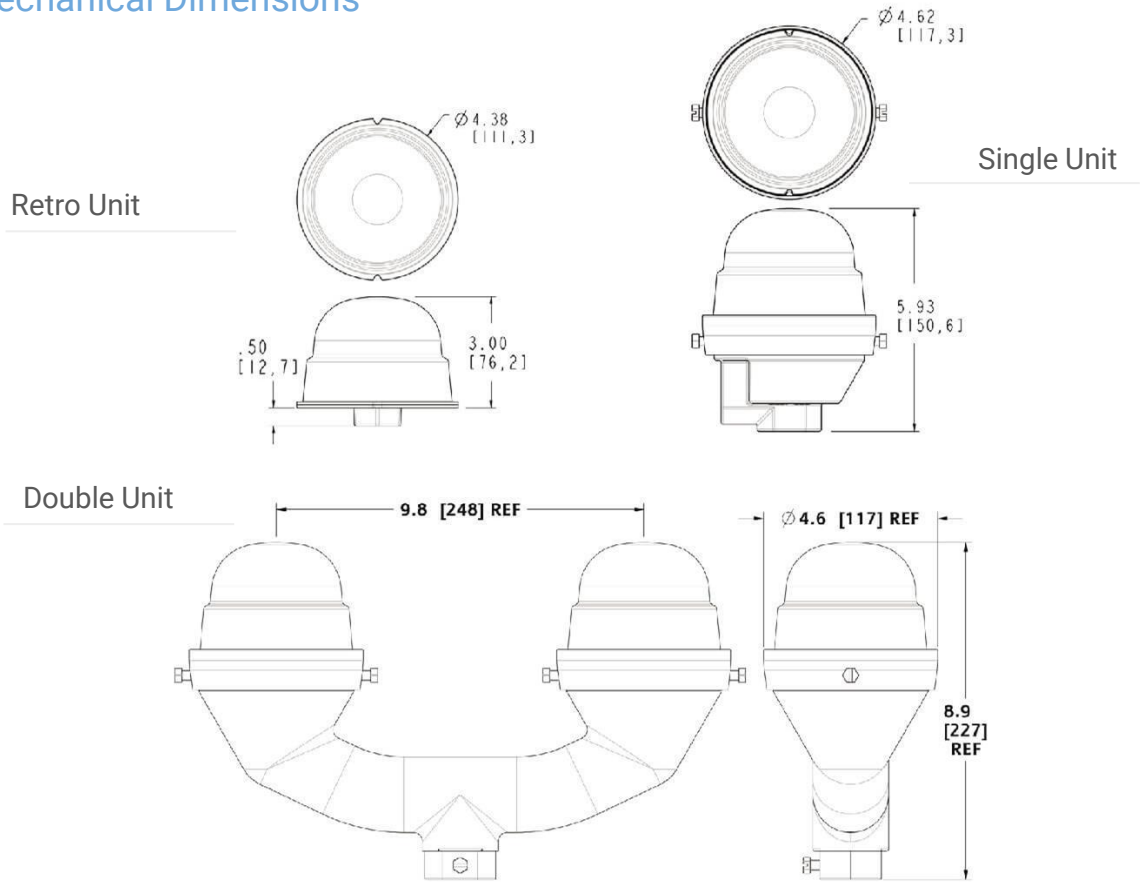

Weights and Measurements

Model	Shipping Wt	Container Dimensions
Retro Unit	1.25 Lbs	7.60" x 5.25" x 5.75" (193mm x 133mm x 146mm)
Single Unit	2.00 Lbs	7.60" x 5.25" x 5.75" (193mm x 133mm x 146mm)
Double Unit	4.60 Lbs	18.6" x 12.5" x 6.40" (472mm x 318mm x 163mm)

Ordering Information

Part Number	Description	Input Voltage
12004-RTO-ER08-001	Single Light - 3.5W (for use with L-864/L-865 systems)	12-48 VDC
12004-RTO-ER08-002	Double Light - 7W (for use with L-864/L-865 systems)	12-48 VDC
12004-RTO-2R07-001	Single Light - 6.5W (for use with L-864/L-865 systems)	120-240 VAC
12004-RTO-2R07-002	Double Light - 13W (for use with L-864/L-865 systems)	120-240 VAC