



ELECTRIC SCOOTER // // // **MINIMOTORS**  
***SPEEDWAY IV***

PERSONAL MOBILITY

User Manual

## Brand Introduction

'DUALTRON' brand is a worldwide electric scooter brand name that Minimotors Co. LTD., is manufacturing.



## Company Introduction

**Minimotors Co., LTD. is a personal mobility manufacturing and distributing company with a professional production system that has been out of personal mobility since 1999.**

Minimotors Co., LTD. has been making the electric mobility brand [DUALTRON] to meet the people of the world with the aim of making more innovative, more sensuous, and more convenient personal mobility from 1999 to the present and making a product that is loved by people in the world. Minimotors Co.,LTD. Is doing its best to become the world best electric mobility company.



## Before Reading Manual

**01** This manual contains important information to help you use your product more safely. Failure to follow these instructions could be the cause of property damage and serious injury. For safe use, it is marked as 'Danger', 'Caution' and 'Warning' depending on the degree of danger and the meaning is as below.



Indicates a hazardous situation that could be a result of serious injury.



Indicates a potentially hazardous situation that could be a result in serious injury.



Indicates a potentially hazardous situation that could be a result in light injury.

**02** Please read this manual carefully before using this product. If you have any problems with your product, you can get technical support from our head office or a seller. ([www.dual-tron.com](http://www.dual-tron.com))

# Speedway4 User Manual Contents



|   |    |
|---|----|
| 1. General safety guidelines and restrictions ..... | 04 |
| 2. Safety precautions for Lithium-ion battery ..... | 06 |
| 3. Product Components .....                         | 08 |
| 4. Name of each part .....                          | 09 |
| 5. How to use the product .....                     | 10 |
| 1) How to assemble .....                            | 10 |
| 2) How to unfold .....                              | 11 |
| 3) How to fold .....                                | 12 |
| 4) How to charge .....                              | 13 |
| 5) Checklist before using.....                      | 15 |
| 6) Safe driving tips.....                           | 17 |
| 7) How to start .....                               | 18 |
| 8) How to stop .....                                | 19 |
| 9) How to control dashboard.....                    | 20 |
| 6. How to maintenance .....                         | 22 |
| 7. Product specification .....                      | 27 |

## General safety guidelines and restrictions



### 1. Be careful of water!

Speedway4 is not waterproof product. Never use when it is rainy or snowy and if the road is wet or icy. Electric device, motor, battery and the other parts can be damaged and it can be the reason of the malfunction or fire. The damage from the water is not free even though it is in warranty period.



### 2. Be careful the point can be caught in as a folding parts and spinning parts!

If a part of the body as a finger or hair touch or be caught in the spinning parts as a tire and wheel disc or folding part and handle parts it can be a cause of the big problem of the body. Before driving, make sure the cloth or shoes rope doesn't meet or caught in the spinning parts.



### 3. Don't tune by yourself. Electric shock can be occurred!

Don't open or tune the electric parts(controller, battery and motor system). It can be the cause of malfunction and fire. And then, You will be charged when you repair your scooter even though it is in warranty period.



### 4. Be sure to wear safety equipment before use and comply with the Road Traffic Law.

All vehicles involve risks and requires the ability to cope with safety. For the safety of passengers, be sure to wear a helmet and protective gear(knee guards, etc.) and follow the Road traffic law.

5. For safety, beginners should practice in the wide area in slow start mode in advance.
6. This product is for one person and it is prohibited by law to drive with an infant or drive with the two passengers. It can be cause of product breakdown and accidents.
7. Standing products must be handled securely with both hands as it is not safe to drive with one hand.
8. Do not use if the braking force is abnormal after checking the operating condition of the brake.
9. If the obstacle appears suddenly, be careful to do not stop the scooter with your foot without using the brakes.

10. Stop the vehicle by stopping the rear brakes properly when stopping, and be careful as there is a risk of overturning if the front brake is applied suddenly while driving.
11. In case of high speed driving, braking distance is longer than low speed.
12. Never use in a slippery place.
13. Never use in an unsafe place such as a driveway, a crowded area, or on a steep slope.
14. Never use on pavements or roads where has a risk of accident of the passenger or the other people.
15. Never use on uneven surfaces.
16. When you pass the speed bump or obstacles, you should slow down. If you don't slow down, it can be a cause of product malfunction and accident.
17. As handlebar is designed to change direction and balance, do not push or pull it with excessive force. If there is a large play on the handle bar, stop the driving and check the head bearing. If the bolt or nut is loosened, you have to drive after fastening it..
18. Please be sure to charge with the dedicated charger provided. If you use a non-compliant charger, be careful because it is fatal to the circuit or battery.
19. Problems caused by using non-compliant chargers and abnormal methods are not covered under warranty.
20. If the product is flooded, disconnect the power supply from the battery and have it serviced by the place of purchase. (In case of flooding or malfunction due to the user, it is not covered under warranty.)
21. Please note that if you set the kickstand up and drive or apply excessive force to the kickstand, it will be broken.
22. Children's use is prohibited and should be used safely under the care of the guardian if they should use.
23. Before use, be sure to check the normal operation of the brake. If the braking force is weak, make sure to adjust it before using.
24. If tire pressure is low, puncture may occur while driving. Be sure to replenish air pressure before use it.
25. When crossing a crosswalk, please get off and carry the product and do not park on the pedestrian road for the pedestrian safety.

## Safety precautions for Lithium-ion battery



### 1) Proper Lithium battery management tips

1. Only use the charger that was supplied with your product to charge lithium-ion battery. Use of an unauthorized charger could cause serious damage to the battery and can cause fire.
2. Charge lithium-ion battery within 0-45°C and discharge within -20-60°C. Charging and discharging the battery not within the appropriate temperature may damage the lithium-ion battery.
3. Do not leave lithium-ion battery in any place exposed to direct sunlight or high temperature. Do not store it in wet places. Always store it in dry places.
4. Charge lithium-ion battery in dry, open, and well-ventilated place. Do not charge the battery near inflammable goods.
5. In the winter, bring the battery from outside to inside, temperatures changed from low to high and this may cause dew condensation. In this case, do not charge the battery immediately, but charge it after reducing temperature difference.
6. If the battery protection circuit is damaged, the battery emits an unusual smell, or the battery leaks, contact the authorized service center immediately and get technical support.
7. Put lithium-ion battery in a safe place out of the reach of children and pets.
8. Do not reverse the polarity on a battery and short-circuit. Also exposing the battery to excessive shock can result in an explosion of the battery.
9. Do not do stunts or jumps on the product on bumpy surfaces. Exposing a battery pack to excessive shock can result in fire on the battery. If there are some crashes while driving, then you should remove it out of the product to check whether the battery is working well.
10. Connecting the charger when the product is waterlogged, the risk of electric shock and fire is very high. Do not charge the battery in this case and the battery should be checked by an expert before charging.
11. Do not disassemble or incinerate lithium-ion battery. To safely dispose of lithium-ion battery, put it as industrial waste and be careful not short-circuit occurs in the terminals.

12. If the battery requires replacement after long-term use, replace it with the new one through the authorized dealer. Normally, the discharge capacity of lithium-ion battery normally decreases more than 15% after 300 times of cycle use.
13. Do not use the battery if it leaks or gives off an odor, and short-circuit inside the battery pack. Lithium-ion is inflammable material. Avoid charging the battery without proper care. Be very alert to the time that you have charged the battery to prevent fire.
14. External temperature effects much on the battery. In winter, when the temperature is low, the performance of the battery degrades, driving distance and power are reduced, and when the weather gets warmer, it returns to its original state.
15. When the scooter needs to be stored longtime without using, keep it with charging around 70~80% from the max charging.
16. Use only with the authorized and recommended battery and charger. Manufacturer and distributor cannot be held responsible for any damage of your product by using unauthentic battery and charger.
17. If a product with a lithium-ion battery detects overheating, smoke, or ignition, you should stop charging and using it immediately, move the product outdoors as soon as possible, and then evolve using a fire extinguisher. As it is more dangerous, do not spill or immerse the water on the product to evolve.

## **2) Additional seasonal lithium battery management methods**

### **(1) Summer battery management**

1. Avoid rainy or hail day or wet roads after rain. Battery and core components may be damaged by flooding, which cause malfunction or fire.
2. Avoid direct sunlight in summer and do not store or charge it in a car trunk or hot room.
3. If it suddenly rains while it is standing up, do not turn on the power or charge it.

### **(2) Winter battery management**

1. If you run on snowy or rainy days, or on frozen or wet roads, you may be injured by flooding the battery and core components, which cause malfunction or fire.
2. When storing the battery, keep it at room temperature(10~20°C) in a place where is not humid and can avoid snow, rain, direct sunlight.
3. In winter, do not charge the battery immediately after driving and wait 1 to 2 hours for charging.

## Product Components

ELECTRIC SCOOTER MINIMOTORS  
**SPEEDWAY IV**



### Check the components inside of the box

**Top** : Protective Styrofoam. Basic tool

**Bottom** : Body / Default charger(2A), Basic tool(Assembling parts), Charging cable, User manual

As shown in the picture above, the box consists of two stages and contains the contents related to the product. Please check if the contents are the same as the picture when you open and please get the help of the service center if the user can not assemble it.

\* Battery pack of each model is installed with the product when it is shipped.

### After assembly of the product



### How to check the product serial number



After open the box of the product, note serial numbers and keep for easy recognize.

How to check the product serial number.



## Name of each part

ELECTRIC SCOOTER **MINIMOTORS**  
**SPEEDWAY IV**



### Important notice

**\* When turning on the product power Turn on the 1)LCD dashboard for starting driving. When the 7) light button is turning on, the power of dashboard will not be on.(Shot time anti-theft function)**

**\* Speedway4 dashboard power may turned off automatically if it is not used for a few minutes.**

## How to use the product

### 1) How to assemble



#### (1) Pulling out the product Danger

1. If the product is lifted with only handle bar, the inner shaft may be damaged due to the much load on the folding parts.
2. Therefore, when lifting the product, it is better to raise the handle bar first, then lift the body(deck part) of the product with both hands and lift it slowly to prevent damage to the folding part.



#### (2) Assembling headlight

1. Loosen the red screw in the circle position with a 5mm hexagon wrench on the basic tool.
2. Adjust the position of the headlight holder and tighten the fixing bolt.
3. Adjust the position by pressing the head of the headlight at the angle appropriate for the user



## 2) How to unfold

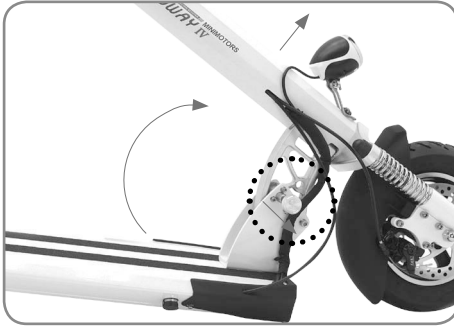

### (1) Releasing the folding lever

Lift the handlebars up with one handle slightly to create a play. With the other hand, pull out the folding lever which is engraved letter S.



### (2) Raise the handle post

Push the handlebar in the direction of the arrow and hold it firmly, then the folding lever is automatically locked. **After installing the handle bar, make sure that the folding lever is fully inserted for safety.**

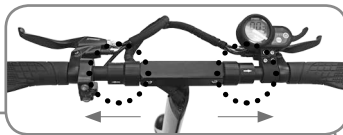

### (3) Unfold the handle parts

1. Unlock the QR lever and pull the handle post up to the height of the user.
2. Unfold the folded handle in the direction of the arrow. Pull out the circle position of the handle as if it is pulled out. The left and right handles are all extended as shown above.
3. **Height adjustment lever(QR lever) must be locked and locked for driving safety.**

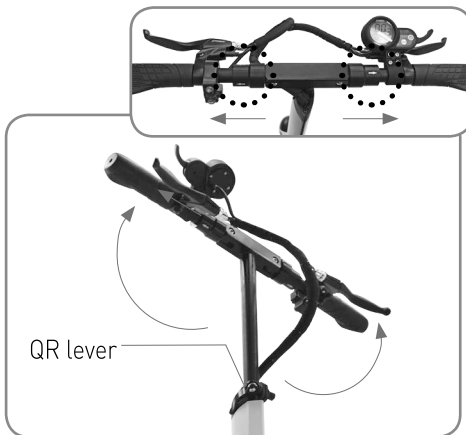

## How to use the product

### 3) How to fold

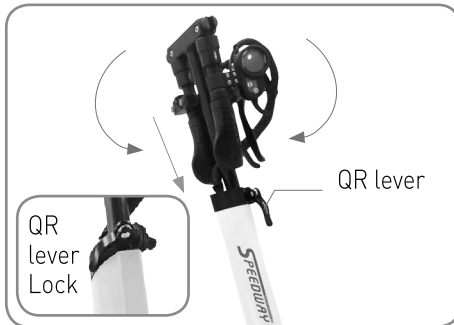

#### (1) Folding handle

Fold the handle down in the direction of the arrow. Open the QR lever and push down on the handle bar with one hand, then lower the height. **Lock the QR lever so that it does not move.**



#### (2) Folding handle post

Hold the handle with one hand and pull the S letter folding button slightly with the other hand to fold down the handle post in the direction of the deck. It would be easier if you push the handle post forward and operate the S letter folding button.



#### (3) Fixing folding part

When you hear a click sound that means the S letter folding button is inserted, the handle post folding is completed. **Before driving, make sure that the folding (S letter folding button) is fully inserted. Be sure to check if the vehicle is traveling without it, it may cause damage to the folding part or lead to an accident.**

## 4) How to charge

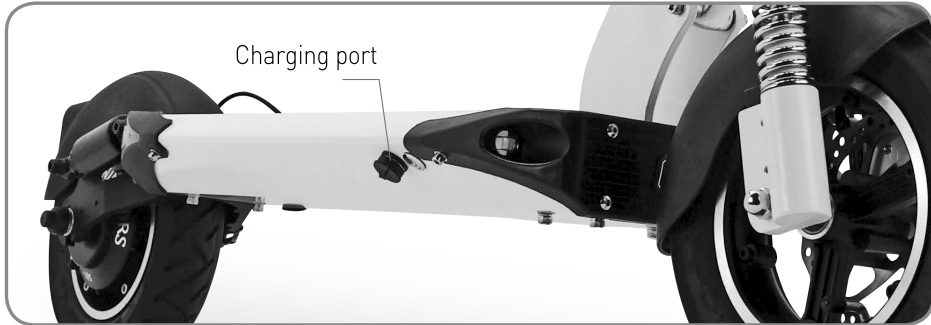

### (1) Standard charging method

1. As shown in the picture, you can open one of the two right-side charging ports and connect them to the charger's connector and connect them into a household outlet.
2. Charging status indicator, Red: not fully charged, Green: fully charged.
3. except when charging.
4. When connecting the connector to the charging port, metallic sparks due to the voltage difference may occur, but this is normal.



**\* CAUTION :** Do not multi charge the battery in case of quick charging. If you want to charge with the two chargers, you must use the 2A charger.

### (2) Charging method when using multi charging socket(Option)

1. Make sure to use only the genuine 2A charger(It may cause electrical trouble when using non-standard charger and cause serious damage to the battery.)
2. All chargers connected to the socket should use the same charger only. (Do not mix different chargers with each other.)
3. Connect the charger connector to the main body first, then connect the charger to the charger connector before connecting the AC cord.
4. If the charger indicates green light, it is fully charged, so disconnect the AC cord of the charger and remove the socket from the main body.



**\* CAUTION :** Using multiple non-standard chargers or using different voltage chargers may be the reason of insufficient charging or fatal damage to the battery or electrical system.

## How to use the product

---

### (3) How to use the charger correctly

1. Do not use the charger and contact the service center if the lamp of the charger does not light, or if there is an external shock or damage on the cable cover.
2. Charging terminals should be firmly contacted when charging. Do not use if terminals are corroded.
3. Do not remove the terminal while charging. This can cause considerable stress on the charger's internal circuitry.
4. When using the charger, do not put any drink that can be spilled around and do not operate the machine with the motor.
5. This charger is prohibited in places with high humidity, heat, or flammable materials.
6. Do not modify the charger or use any other charger.
7. We recommend that you always use a dedicated charger. Performance and safety are not guaranteed when using a charger other than the dedicated charger.
8. Charger failure may cause a fire while charging. Be sure to disconnect the charger terminal when you leave the place for a long time.
9. If charging is not completed for a long time, do not use the charger and contact a service center.
10. If the child uses a charger, please use it under the supervision of a guardian.
11. Do not insert metal into the charging hole.
12. After unplugging the charger, do not touch the plug for about 10 seconds.
13. Do not attempt to disassemble, open, crush, bend, deform, perforate, shred or submerge the charger.
14. Be careful not to drop the charger or subject it to excessive shocks.
15. Before using the charger, carefully read and understand the instruction manual and use it safely.

## 5) Checklist before using

### Important notice

Be sure to check the normal operation of the front and rear brakes before use. If the brake operation is not good, be sure to adjust the brakes to ensure braking.

### (1) Safety equipment must be worn before use

This product is a product that can be driven by two-wheel and high speed. All users must use the product after preparing as wearing a helmet on their head and additional protectors(knee, elbow, palm) before use.



### (2) Beginners, women, and elderly people Do not use high-speed mode or dual mode

Beginners and elderly people who have never used the product for the first time or have difficulty in speed control must use low speed mode (ECO) because of high risk of accidents when using high speed mode and dual mode. And single mode. For beginners, it is prohibited to use high speed mode (TURBO) and dual mode on the ground or downhill. Dual mode can be used only for the limited time. \* Pregnant women are prohibited from using.



### (3) Do not accelerate downhill

If you accelerate downhill, the braking distance is too long to be dangerous. If necessary, use the brakes properly. On very long downhill roads, the brakes may overheat and may not work.



### (4) Motor and brake burns Caution



Since the temperature of the motor and brake (especially the disc rotor) increases after running, there is a risk of burns when.



## How to use the product

### (5) When lifting the product after folding the handle

When folding the handle and lifting the product by lifting the handle, the load of the main body may be concentrated on the folding part, which may damage the folding part. When folding the handle and lifting the product, hold the body(Deck) with both hands as shown in the picture.



### (6) Be careful when reassembles the bolt after removing the side cover



If you reassemble after removing the side cover for LED tuning or inspection, make sure that the spring washer is inserted into the bolt. If you assemble without a spring washer or use a bolt longer than the standard, the bolt will penetrate the battery, which cause a serious damage to the battery and serious safety problems such as fire.



### (7) Checking of main fixing parts before driving



Always check if the bolts and nuts fastened to the fixing parts are loosened due to the vibration from continuous driving or if some parts are lost, it may occurs safety accidents. Check the tightening of the nut and use it after self-maintenance or visit the nearest repair shop after stop using it immediately if there is any problem. In particular, make sure that the steering bolt at the bottom of the front fenders that connects the handle to the front wheel is well tightened.



### (8) Fixed state of the QR lever before driving.



Make sure if the QR lever is correctly fixed when the handle is extended. If the QR lever is not fixed correctly, the steering wheel may fold while driving, which may be causing an accident, so make sure that the QR lever is correctly tilted inward as shown in the picture before driving





## 6) Safe driving tips

1. Read the instruction manual that came with the product to understand the features of the product you are using.
2. To prevent a safety accident, wear safety gears such as comfortable shoes, knee protector, helmet and elbow protector.
3. Find a space no pedestrians and cars where is flat and not wet that good to practice for a novice.
4. Hold the foot in the most comfortable position on the deck with no power applied.
5. Take the proper foot position to do not place weight on the handle, and practice to look around the front and back sides when driving.
6. Check where the power supply and accelerating and decelerating devices are located. (Brake position, Acceleration throttle position)
7. For night driving, check the position of the light and the state of the taillight when you hold the brake.
8. Turn on the product and check if it is the speed mode for beginners(beginners should start in safe mode).
9. Check the battery level to make sure if it is enough for driving.
10. Take a look at the various functions of the dashboard and make the appropriate settings for the user. Do not change settings other than the dashboard settings displayed in the user manual(including fixed values). Changing the settings may result in a safety hazard, which is the user's responsibility.
11. Please start and end first driving where there are no obstacles such as people and loads.
12. Hold your feet in a comfortable position on the deck and control comfortably and smoothly.
13. Practice to slow down and stop to cope with various factors that may occur when driving.
14. When turning left and right, make sure that there are no obstacles and then turn slowly with keeping a wide turning radius.
15. If movement to backward is required, it is safe to move down from the product after decelerating and stopping.

**\* In this case, stop driving immediately.**  Caution

1. If the product is noisy while driving, stop driving immediately and consult with the nearest repair shop. (If you prepare a video for checking the noise, much better to consult)
2. If you feel that there is a problem with the operation such as the error message on the dashboard, the heat of the motor, the incomplete operation of the brake and etc., stop and consult with the nearest repair shop.

## How to use the product

### 7) How to start



#### (1) Turning on the main switch

When the button of the main power switch is set to 'I'(IN), the built-in battery and the BMS are activated and ready to start driving. When driving is finished, press 'O'(out) of the main switch to prevent battery consumption.



#### (2) Turning on the dashboard

After turning on the main power switch, press the power button on the dashboard for 2 seconds to turn on the dashboard. Users can determine the appropriate departure speed for users, using the cruise mode and using the electric brake, etc. in the detailed mode.

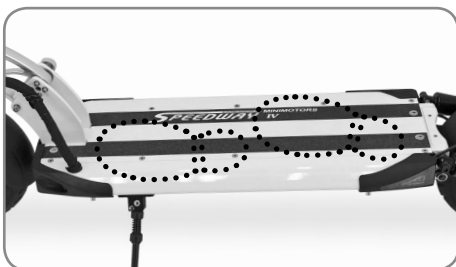

#### (3) Stance for driving

After tilting the kick stand, find a stable position on the deck and then hold the handle grip comfortably. (Be sure to turn on the light button when driving at night.) Be careful not to raise your foot on the rear fender. Excessive load can cause malfunction due to overheating of the motor.



#### (4) Acceleration and deceleration

Acceleration can be performed by using the throttle of the dashboard while driving, and the deceleration or stop can be performed by holding the brakes on both handles.

## 8) How to stop



### (1) Decelerate with rear brake

When stopping while driving, use the rear brake to decelerate slowly. There is a risk of overturning when braking suddenly with front brake. It is necessary to practice to stop after decelerating safely with the rear brake.



### (2) Stop safely

Always use the front and rear brake levers together to stop smoothly and safely after decelerating with the rear brake.



### (3) Deceleration and brake with electric brake

Be sure to set whether or not to use and strength of the electric brake among the detail functions of the dashboard beforehand. If the use of the electric brake is set, the electric brake works together with the brake lever when driving to increase the braking power.

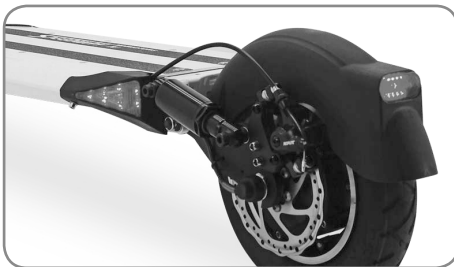

### (4) Check for safe braking

For safe braking, be sure to check for any external changes (bending, exfoliation, disconnection, etc.) on the brake cables and lines before driving. If the braking force of the brake drops considerably even during use, it should be used after the inspection and repair.

## How to use the product

### 9) How to control dashboard



#### (1) Dashboard main screen → Adjusting the speed step

To adjust the speed level in the main screen while the dashboard is on, press to display the currently set speed level. At this time, press the button to set the speed step (L1 - low speed, L2 - medium speed, L3 - high speed). Press to confirm the set speed step value and finish setting.

#### Information

- \* When L1 (low speed) is selected, slow start does not work even if P7 (start mode) is set to slow start in the detail function.
- \* When selecting L3 speed (high speed), exceeded speed may be temporarily displayed on the dashboard in the full accelerator state, which is different from the actual speed

#### (2) Mode functions and setting method of main screen

Each time you press the button briefly on the main screen, the mode changes to the next mode.

| Mode  | Description   |
|-------|---|
| TRIP  | Current mileage (Press and hold the mode button to set "0") |
| ODO   | Accumulate mileage  |
| CHA   | Not used  |
| VOL   | Current voltage (Volt)                                      |
| DST   | Not used  |
| TIME1 | 2 hour stopwatch  |

\* Note : The voltage displayed in VOL mode has about 1V ~ 2V difference from actual battery voltage

#### (3) Returning to the main screen after setting details

Press again to finish all settings and return to the main screen.

#### (4) Setting detail functions of the instrument cluster

| Mode | Display values and settings                       |
|------|---|
| P0   | 10 (Can not change)                               |
| P1   | 430 (Can not change)                              |
| P2   | 10 (Can not change)                               |
| P3   | 0 (Fixed)   |
| P4   | Speed display / Km/h(0), mp/h(1)                  |
| P5   | Start mode / Accelerator start(0), Kick start(1)  |
| P6   | Cruise mode (Auto driving) / Off(0), On(1)(1)     |
| P7   | Start speed / Power start(0), Slow start(1)       |
| P8   | Max speed setting / 1~100%                        |
| P9   | Electric brake power / Off(0), Medium(1), Hard(2) |

## (5) How to enter or return to the detail function setting screen from the main screen



**Ex) P0 default value setting**

You can return to the normal screen or entering the function setting of the dashboard by pressing the power button together with the mode button to the right index finger and the left index finger on the main screen.

Press MODE and POWER button for about 2~3 seconds to enter P0 mode. → Press once to change set value. → The setting value is blinking and displayed below. At this time, press the button to change the setting value. → Press the button to increase the setting value, and press to decrease the setting value.

\* When the setting is finished, press the button for 2~3 seconds to activate the setting value.

\* Press to move between P0 mode and P9 mode, and press to change the setting value.

## (6) Features of cruise mode

The cruise control function allows you to maintain the driving speed automatically. The advantage of using the cruise function is that you can reduce fatigue during long distance driving and fuel consumption.

### \* Starting the Cruise function

- Select the Cruise function part of the dashboard as 'Settings'.
- If the throttle is kept at the same acceleration for about 7 seconds, the cruise function starts.

### \* Ending the cruise function

When you hold and release the brake while the cruise mode is running, the cruise mode is automatically canceled.

### \* Precautions when using the cruise function



In order to release the cruise function in response to the safety situation while driving the cruise function, **be sure to travel in a position where the brake can be used immediately so that the brake can be applied. When switching single mode to dual drive mode in a cruise mode, cruise mode can not be released with using throttle and can only be released via brakes.**

## (7) Intensity adjustment of electronic brake

The Speedway4 is equipped with a physical brake that brakes the front and rear wheels and can be braked by pulling the physical brake lever on the handle. If '1' is selected for P9 of detail function setting of the dashboard, it is medium intensity and if '2' is selected, it is a hard intensity which the maximum braking force. If '0' is selected, the electric brake operation will be off.

### \* The electronic brakes will not operated when the battery is fully charged.



Do not use electric brakes immediately after full charging. **For your safety, it is recommended that you do not use the electric brake in a fully charged condition, but use the electric brake only when more than 5% of the battery capacity is used.**

## How to maintenance

### 1) How to check the product daily before and after driving



#### (1) Check brake and cable

- Before driving, make sure that the braking force is sufficient and the operation is good.
- If the braking force of the brake drops considerably even during use, it should be used immediately after the inspection and action.
- When checking, make sure that the brake pad is not worn, the cable is not loose, and the cable is not damaged.
- Brake cable is a consumable item depending on the user's driving environment. When operating the brake lever, if there is a feeling of being caught unusually or when operating noise is occurring, check if the inner wire of the cable is partially broken, worn or deformed. If you do not pay attention to repetitive handle folding, the brake cable may be broken or deformed, which may cause the operation to be ineffective or the wire may be broken unexpectedly due to damage of the inner wire. Be sure to check before you drive to decide whether to replace or drive.
- Make sure that the bolts, nuts and the various fixing parts of the brake are not loose, and the disc is not deformed or damaged.



#### (2) Tire pressure check and uneven wear caution

- Check the condition of the front and rear tires. Check the condition of wear and puncture and keep tire pressure (proper air pressure 45) properly. When the air pressure is insufficient, the travel distance becomes shorter and the possibility of puncture increases.
- It may cause uneven wear of tires when the tire is suddenly stopped and which makes dangerous situation. Therefore, it is necessary to judge the replacement time by observing the appearance of the tire.



#### (3) Tightening check such as folding part and handle part

- Check the product thoroughly before use.
- Always check that there are play in each part, that the bolts and nuts of the folding or handle parts, the whole fixing parts of the product are properly tightened and that the fastened parts are not loosened.





#### **(4) Checking when to replace consumable parts**

- Spare parts such as tires, tubes, discs, pads, cables and brackets, forks, etc. which require periodic inspection and replacement are subject to replacement at different times. Therefore, periodic inspection and maintenance is required.

#### **(5) Electric products can be damaged by various factors!**



- As with all machines, this product may also fail due to a number of factors. The life of each part can be different depending on the driving habits. Parts exceeding the durability of the product may be damaged and cause accidents. Brake cables and various cables as well as forks or brackets on the car are consumables that can become worn or bent depending on the external driving environment. Therefore, it is recommended to visit the repair shop for replacing and safety inspection as the basic shape deformation, cracking due to compression, crack or discoloration which shows durability of the product is low

## How to maintenance

### 2) Speedway4 rear suspension 2step tension adjustment



#### (1) Release for rear suspension tension adjustment

- Use a 6mm hex wrench on both sides of the motor side rear suspension fixing bolt.



#### (2) Move the rear suspension to the second stage hole position to adjust the tension

- Use a 6mm hex wrench on both sides of the motor side rear suspension fixing bolt.

\* **CAUTION** : If one side is tightened first, the opposite side may be deflected. Tighten tightly after tightening.



**Notice** : The below pictures show Dualtron as an example and applies to Speedway4 as well.

### 3) Brake adjustment method

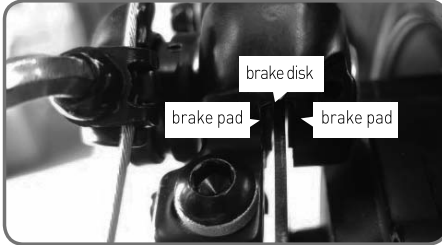

As you continue to use the brakes, the brake pads become worn out and the gap between the pads and the brake disc becomes wider. When the braking power drops, it can be adjusted simply as shown in the picture below.



(1) As shown in the picture, if you release it with a 5mm hexagon wrench, the caliper will be detached.



(2) Caliper will be separated as the picture



(3) A small set screw hole is shown in the picture. The role of this bolt is to keep the brake pads on the motor stationary. So, after adjusting the pad, you have to lock it again



(4) Release the set screw with a 2mm hex wrench in this way.



(5) Next, turn the pad clockwise with a 5mm hexagon wrench to make the pad closer to the disk, and turn it counterclockwise to move the pad away from the disk.



(6) Turn it clockwise in this state.

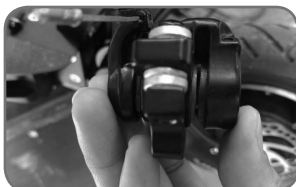

(7) It will enter as shown in the picture.



(8) When reassembling, the left and right alignment may not match. In this case, the two upper bolts are loosened as shown in the picture to adjust the calipers' body to the left and right.

## How to maintenance

**Notice :** The below pictures show Dualtron as an example and **SPEEDWAY IV** applies to Speedway4 as well.

ELECTRIC SCOOTER // MINIMOTORS  
**SPEEDWAY IV**

### 4) Causes and Countermeasures for Noise of Disc Brake

The disc braking system has a good braking power, so many electric scooters use disc braking. However, if you get a sharp chirping sound when you take a disc brake, you can make a simple correction in the following way. Most of the causes of disc brake noise are dust or sand scattered on the ground during driving, which caused foreign substances to adhere to the brake pad or disc surface.

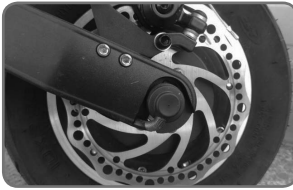

(1) It is a common disc pad and caliper.



(2) There is a stripe on the part where the pad touches, but it does not look dirty when you see it with your eyes.



(3) Prepare a clean dry cloth.



(4) Prepare a clean dry cloth.

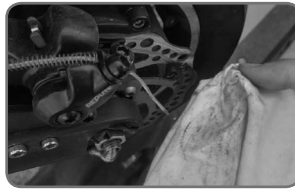

(5) Turn it several times and wipe.



(6) Brake sound is simply eliminated.

#### Note:

If you can't solve it with the method above, visit the nearest repair shop and take a safety check. There may be another problem.

## Product specification



| Product Name     | Speedway 4  | Note  |
|------------------|---|---|
| Motor type       | 52V 600W BLDC HUB motor   | Rear wheel drive  |
| Battery type     | EX plus   | Li-Polymer high discharging cell  |
| Battery capacity | 26AH (1347Wh)   |   |
| Product weight   | Around 23.7kg   | Battery included  |
| Charging hour    | 11-12hr   | Depending on the battery condition  |
| Charging hour    | 85-100km  | 60kg load<br>25 degrees of ambient temperature<br>Based on the flat road 20km/h<br>constant speed driving                               |
| Max speed        | 15km/h(L1), 35km/h(L2), 45km/h(L3)  |   |
| Folding          | Handle one touch quick folding(S Button)<br>/ Handle bar one touch slide folding  |   |
| Gradeability     | Length x Width x Height   |   |
| Unfolding size   | 121 x 57.5 x 118cm  | Length x Width x Height   |
| Folding size     | 124 x 25 x 40cm   | Length x Width x Height   |
| Dashboard        | Multifunction smart LED dashboard<br>(Battery level, voltage, trip, ODO, driving speed, driving speed and mode change function) | Cruise function / Electric brake function / Slow-Power start function, Kick start-Accelator start function / Auto save power(3 minutes) |
| Button function  | LED headlight&Taillight(Red button) / Electric horn(Green button)   | Left and Right signal light switch<br>Deck right bottom front lamp button (Power button)  |
| Brake system     | Disk brake(Front&Rear) + Electric brake   | For both front&rear / When the electric brake function is set on the dashboard  |
| Suspension       | Hydraulic spring suspension(Front)+Air Suspension(Rear)   | Front and rear dual suspension  |
| Tire size        | 10inch(10x2.5) Wide tube tire<br>(Proper air pressure 45psi)  | Tire width<br>Around 5.8cm  |
| Product material | Special aluminum alloy (Flame, steering handle bar),<br>ABS(Cover)  | CNC method casting  |

\* Parts and specifications are can be changed without notice to improve product quality and safety.

\* The mileage on the above specifications is measured on 60kg loading, 20km/h, and flat road continuous(nonstop) driving. If the driving environment and driving method are different, driving mileage may be different.

\* The mileage can be greatly affected by the loaded weight, the ambient temperature, the wind direction (wind speed), the road surface condition, the slope, the tire pressure and so on.



**SPEEDWAY IV**  
Electric Scooter  
User Manual