



TECHNICAL FILE

Skylux® 160° CE LM

Electric skylight for
smoke and heat extraction

CE approved according to EN 12101-2
and in conformity with NBN S21-208*

Hello daylight!

General product description

The Skylux® 160° CE skylight consists of:

- An EN approved Skylux® skylight** in acrylic, polycarbonate, glass (iWindow2 or 3), hybrid (iDome) or Pergotop assembled according to the Skylux® specifications.
- A PVC curb (type 16/00, 30/20 or 35/30), polyester (PO30 or PO50), metal, timber or concrete, with a composed height of at least 300 mm and which is part of the CE agreement for SHE systems (see pictures opposite).
- A hinging PVC frame (standard or EP) or a round GRP frame.
- External supporting sheets with accessories for PVC curbs.
- An opening system with one or two 24 volts actuator(s) depending on the sizes and the chosen skylight).

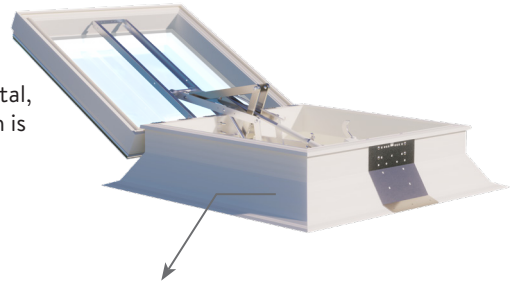

Skylux 160° CE square

Complementary:

- One detection unit Skycom® MASTER CE (+ Skycom® SLAVE CE) in conformity with EN 12.101-(9)/10
- Two angle spoilers (optional to improve the aerodynamic coefficient C_v)
- Inner spoilers (optional to improve the aerodynamic coefficient C_v)



Skylux 160° CE rectangular

Features

- Large range of sizes (up to daylight size 160 x 280 cm) and excellent C_v -values (up to 0.78) decrease the number of appliances needed
- Exceptional insulation (U_t value ***)
 - iWindow2: 1 W/m².K
 - iWindow3: 0.5 W/m².K
- Air permeability class 2 according to EN 1873:2014+A1:2016
- 100 % thermal break
- Skylux® quick mounting concept
- Skylux® 160° CE is also available in round sizes
- Dimensions 100x130 – 100x110 – 120x120 are in accordance with NBN S-21-208-3:2018 for buildings > 10 metres



Skylux 160° CE round

CE specification according to EN 12101-2 for Skylux® 160° CE

Time until full opening	< 60 sec
Min. functioning temperature (°C)	-15 °C
Heat resistance (°C)	B300
Snow load (N/m ²)	SL 500 to SL 1000
Wind load (N/m ²)	WL 1500
Aerodynamic coefficient****	according to size, type curb and spoilers (until 0.78)
Liability SHE	Re 1000
Liability ventilation	Re 10.000
Maximum slope	10°

- * With the use of a Skycom® Master CE and Skycom® Slave CE detection unit, is the installation Fail Safe and the Skylux® 160° CE meets the norms NBN S21-208.1 en NBN S21-208.3.
- ** Skylux® skylights are CE marked according to EN 1873:2014+A1:2016.
- *** U_t (transparent) value or insulation value of the Skylux® skylight according to EN 1873:2014+A1:2016
- **** Always ask for the aerodynamic coefficient determined by lateral wind

Product description opening mechanism

The Skylux® 160° CE is a skylight for smoke and heat extraction equipped with a daily ventilation function. On alarm, the skylight fully opens up to the standard plant regulation (160° or 140° according to the CE certification). Every required opening smaller than 160° or 140° can be set on request (but without CE certificate). The actuator has an external electric final course.

Specific characteristics opening mechanism

	small daylight sizes (≤ 100 x 150 cm)	large daylight sizes (> 100 x 150 cm)
Tension.....	24 V DC - 48 V DC	24 V DC - 48 V DC
Current.....	nominal 2.5 A (per actuator)	nominal 4.0 A (per actuator)
Number of motors.....	1	1 of 2 (see pricelist)
Opening angle.....	160°	160°
Weight.....	15.5 kg	25.1 kg
Final course.....	electronic	electronic
Density.....	IP 54	IP 54
Certification.....	CE according to EN 12.101-2	CE according to EN 12.101-2
Finish.....	white lacquered	galvanised

Product description detection units

The Skylux® 160° CE is operated by a Skycom® Master CE control unit, which meets the EN 12.101-10 norm. This detection unit with operation on the front panel, specially developed for the Skylux® 160° SHE dome, is equipped with several connection possibilities (see technical file Skycom® CE detection unit). The detection unit has autonomy for at least 72h thanks to the incorporated batteries. The number of Skycom® Masters CE and Skycom® Slaves CE is determined per project. The Skycom® Master CE detection unit:

It can operate 1 or more lineair actuators. For installations with several actuators, the Skycom® Master CE detection unit is extendable with extra detection units Skycom® Slave CE. The Skycom® Slave CE is equipped with a temperature sensor as positive safety (Fail Safe) if the norm NBN S21-208.1 or NBN S21-208.3 is required. Cable sections are set in function of the number of actuators and the distance to the Skycom® Master CE detection unit. It is equipped with an operation panel with breakable glass for opening and closing. The LED-lights inform you about the condition of the EFC installation, the (battery) tension, alarm, cable rupture, ...



Remark

To avoid heat build-up under the transparent skylight (plastic, hybrid, glass) and therefore possible deformation or damage to the PVC curb, frame, skylight dome or electrical components, it is recommended that no closed surface (e.g. black closed attic hatch) is installed under the skylights. A reflective (e.g. white) surface and/or ventilation is recommended.

Curb combinations

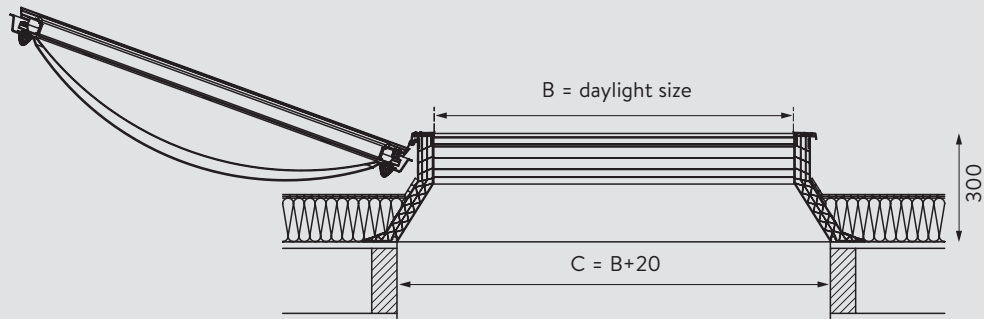

with PVC curb 30/20 (Installation in timber roof construction)

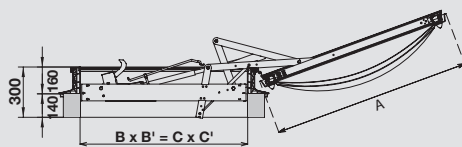

with PVC curb 16/00

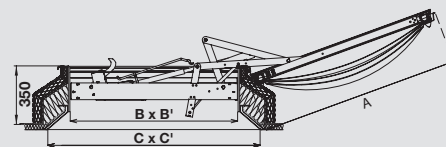

with PVC curb 35/30 in refurbishment project

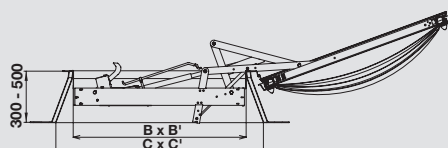

with polyester curb PO30 - PO50

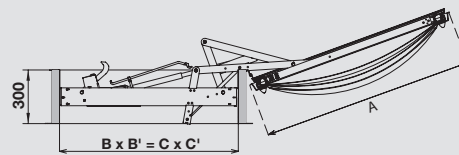

with metal curb M30

Attestations, certificates and documentation

- CE of the SHE system according to EN 12.101-2
- CE of the Skycom® Master CE and Skycom® Slave CE detection unit according to EN 12.101-(9)/10
- In accordance with NBN S21-208*
- DoP on www.skylux.be
- Mounting instructions on www.skylux.be



Attention: the CE certification is only valid if the composition, execution and the installation regulations are respected. Skylux guarantees the CE conformity as described in the documentation and according to the plant regulations of the appliances. Every variance, cancels the CE conformity.

ONLY USE ORIGINAL PARTS DELIVERED BY SKYLUX. EVERY GUARANTEE IS CANCELLED IF NON-ORIGINAL PARTS ARE USED. THE SHE DETECTION UNIT MUST BE USED WITH THE RIGHT SHE OPENING SYSTEM. THE USE OF NON-ORIGINAL SHE PARTS CAN LEAD TO DEFECTS OF THE SYSTEM.

SKYLUX
SPINNERIJSTRAAT 100 - B-8530 STASEGEM
T +32 (0)56 20 00 00 - F +32 (0)56 21 95 99
INFO@SKYLUX.BE
WWW.SKYLUX.BE

