

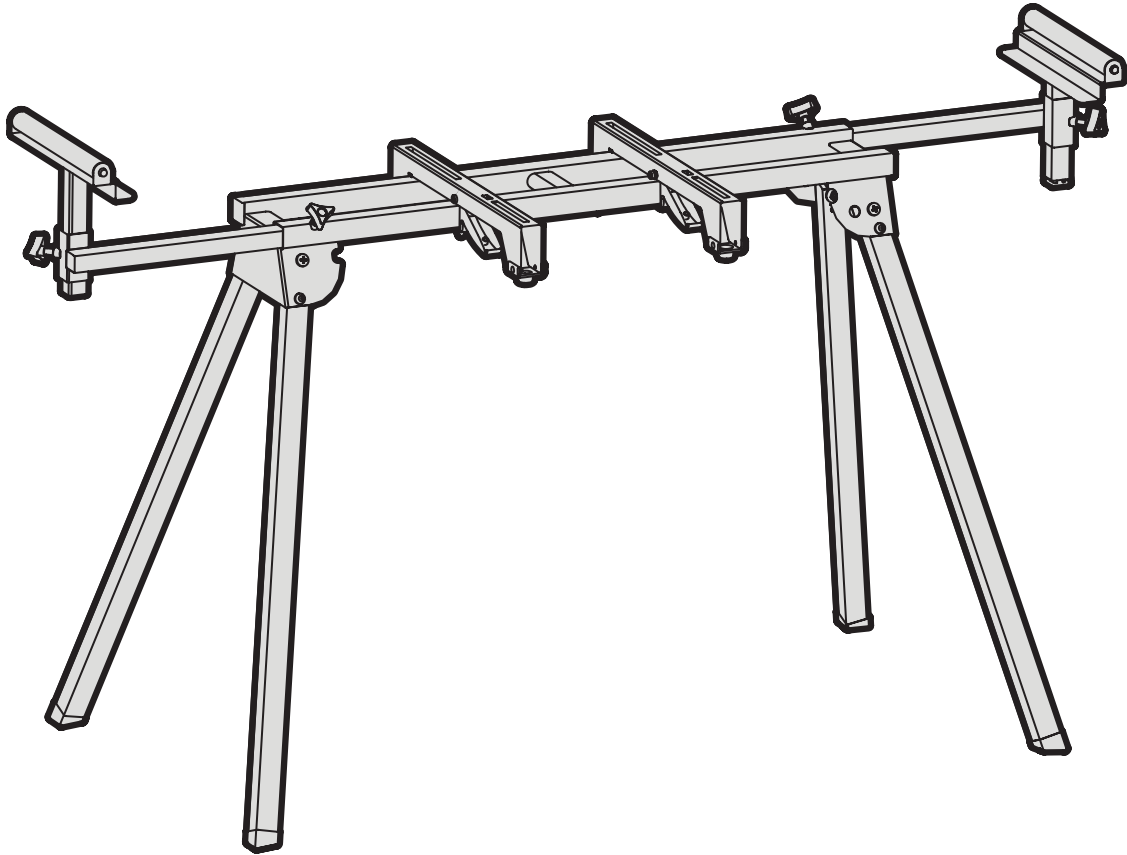

MODEL MSA200

COLLAPSIBLE MITER SAW STAND

Instruction Manual



NEED HELP? CONTACT US!

Have product questions? Need technical support? Please feel free to contact us:



1-847-429-9263 (M-F 8AM-5PM CST)



TECHSUPPORT@WENPRODUCTS.COM

IMPORTANT: Your new tool has been engineered and manufactured to WEN's highest standards for dependability, ease of operation, and operator safety. When properly cared for, this product will supply you years of rugged, trouble-free performance. Pay close attention to the rules for safe operation, warnings, and cautions. If you use your tool properly and for its intended purpose, you will enjoy years of safe, reliable service.

For replacement parts and the most up-to-date instruction manuals, visit ***WENPRODUCTS.COM***

CONTENTS

WELCOME	3
Introduction	3
Specifications.....	3
SAFETY	4
General Safety Rules	4
BEFORE OPERATING	6
Unpacking & Packing List	6
Know Your Miter Saw Stand	7
Assembly & Adjustment.....	8
OPERATION & MAINTENANCE	10
Operation	10
Maintenance.....	11
Exploded View & Parts List.....	12
Warranty Statement	13

INTRODUCTION

Thanks for purchasing the WEN Miter Saw Stand. We know you are excited to put your tool to work, but first, please take a moment to read through the manual. Safe operation of this tool requires that you read and understand this operator's manual and all the labels affixed to the tool. This manual provides information regarding potential safety concerns, as well as helpful assembly and operating instructions for your tool.

 **SAFETY ALERT SYMBOL:** Indicates danger, warning, or caution. The safety symbols and the explanations with them deserve your careful attention and understanding. Always follow the safety precautions to reduce the risk of fire, electric shock or personal injury. However, please note that these instructions and warnings are not substitutes for proper accident prevention measures.

NOTE: The following safety information is not meant to cover all possible conditions and situations that may occur. WEN reserves the right to change this product and specifications at any time without prior notice.

At WEN, we are continuously improving our products. If you find that your tool does not exactly match this manual, please visit wenproducts.com for the most up-to-date manual or contact our customer service at **1-847-429-9263**.

Keep this manual available to all users during the entire life of the tool and review it frequently to maximize safety for both yourself and others.

SPECIFICATIONS

Model Number	MSA200
Maximum Loading Capacity	350 Pounds (158.8 kg) Evenly Distributed
Extension Support Distance	36 in. - 80in. (91.4 cm - 203.2 cm)
Roller Support Width	9.85 Inches (250 mm)
Mounting Bracket Height	31 Inches (78.4 cm)
Maximum Front-to-Back Mounting Distance	14.98 Inches (38 cm)
Maximum Product Dimensions	81 in. x 25 in. x 36 in.
Product Net Weight	22 Pounds

GENERAL SAFETY RULES

 **WARNING!** Read all safety warnings and all instructions. Failure to follow the warnings and instructions may result in electric shock, fire and/or serious injury.

Safety is a combination of common sense, staying alert and knowing how your item works. The term “power tool” in the warnings refers to your mains-operated (corded) power tool or battery-operated (cordless) power tool.

SAVE THESE SAFETY INSTRUCTIONS.

WORK AREA SAFETY

- 1. Keep work area clean and well lit.** Cluttered or dark areas invite accidents.
- 2. Do not operate power tools in explosive atmospheres, such as in the presence of flammable liquids, gases or dust.** Power tools create sparks which may ignite the dust or fumes.
- 3. Keep children and bystanders away while operating a power tool.** Distractions can cause you to lose control.

ELECTRICAL SAFETY

- 1. Power tool plugs must match the outlet. Never modify the plug in any way. Do not use any adapter plugs with earthed (grounded) power tools.** Unmodified plugs and matching outlets will reduce risk of electric shock.
- 2. Avoid body contact with earthed or grounded surfaces such as pipes, radiators, ranges and refrigerators.** There is an increased risk of electric shock if your body is earthed or grounded.
- 3. Do not expose power tools to rain or wet conditions.** Water entering a power tool will increase the risk of electric shock.
- 4. Do not abuse the cord. Never use the cord for carrying, pulling or unplugging the power tool. Keep cord away from heat, oil, sharp edges or moving parts.** Damaged or entangled cords increase the risk of electric shock.
- 5. When operating a power tool outdoors, use an extension cord suitable for outdoor use.** Use of a cord suitable for outdoor use reduces the risk of electric shock.

6. If operating a power tool in a damp location is unavoidable, use a ground fault circuit interrupter (GFCI) protected supply. Use of a GFCI reduces the risk of electric shock.

PERSONAL SAFETY

- 1. Stay alert, watch what you are doing and use common sense when operating a power tool. Do not use a power tool while you are tired or under the influence of drugs, alcohol or medication.** A moment of inattention while operating power tools may result in serious personal injury.
- 2. Use personal protective equipment. Always wear eye protection.** Protective equipment such as a respiratory mask, non-skid safety shoes and hearing protection used for appropriate conditions will reduce the risk of personal injury.
- 3. Prevent unintentional starting. Ensure the switch is in the off-position before connecting to power source and/or battery pack, picking up or carrying the tool.** Carrying power tools with your finger on the switch or energizing power tools that have the switch on invites accidents.
- 4. Remove any adjusting key or wrench before turning the power tool on.** A wrench or a key left attached to a rotating part of the power tool may result in personal injury.
- 5. Do not overreach. Keep proper footing and balance at all times.** This enables better control of the power tool in unexpected situations.
- 6. Dress properly. Do not wear loose clothing or jewelry. Keep your hair and clothing away from moving parts.** Loose clothes, jewelry or long hair can be caught in moving parts.

GENERAL SAFETY RULES

 **WARNING!** Read all safety warnings and all instructions. Failure to follow the warnings and instructions may result in electric shock, fire and/or serious injury.

Safety is a combination of common sense, staying alert and knowing how your item works. The term “power tool” in the warnings refers to your mains-operated (corded) power tool or battery-operated (cordless) power tool.

SAVE THESE SAFETY INSTRUCTIONS.

7. If devices are provided for the connection of dust extraction and collection facilities, ensure these are connected and properly used. Use of dust collection can reduce dust-related hazards.

POWER TOOL USE AND CARE

1. Do not force the power tool. Use the correct power tool for your application. The correct power tool will do the job better and safer at the rate for which it was designed.

2. Do not use the power tool if the switch does not turn it on and off. Any power tool that cannot be controlled with the switch is dangerous and must be repaired.

3. Disconnect the plug from the power source and/or the battery pack from the power tool before making any adjustments, changing accessories, or storing power tools. Such preventive safety measures reduce the risk of starting the power tool accidentally.

4. Store idle power tools out of the reach of children and do not allow persons unfamiliar with the power tool or these instructions to operate the power tool. Power tools are dangerous in the hands of untrained users.

5. Maintain power tools. Check for misalignment or binding of moving parts, breakage of parts and any other condition that may affect the power tool's operation. If damaged, have the power tool repaired before use. Many accidents are caused by poorly maintained power tools.

6. Keep cutting tools sharp and clean. Properly maintained cutting tools with sharp cutting edges are less likely to bind and are easier to control.

7. Use the power tool, accessories and tool bits, etc. in accordance with these instructions, taking into account the working conditions and the work to be performed. Use of the power tool for operations different from those intended could result in a hazardous situation.

8. Use clamps to secure your workpiece to a stable surface. Holding a workpiece by hand or using your body to support it may lead to loss of control.

9. KEEP GUARDS IN PLACE and in working order.

SERVICE

1. Have your power tool serviced by a qualified repair person using only identical replacement parts. This will ensure that the safety of the power tool is maintained.

CALIFORNIA PROPOSITION 65 WARNING

Some dust created by power sanding, sawing, grinding, drilling, and other construction activities may contain chemicals, including lead, known to the State of California to cause cancer, birth defects, or other reproductive harm. Wash hands after handling. Some examples of these chemicals are:

- Lead from lead-based paints.
- Crystalline silica from bricks, cement, and other masonry products.
- Arsenic and chromium from chemically treated lumber.

Your risk from these exposures varies depending on how often you do this type of work. To reduce your exposure to these chemicals, work in a well-ventilated area with approved safety equipment such as dust masks specially designed to filter out microscopic particles.

UNPACKING & PACKING LIST

UNPACKING

With the help of a friend or trustworthy foe, such as one of your in-laws, carefully remove the miter saw stand from the packaging and place it on a sturdy, flat surface. Make sure to take out all contents and accessories. Do not discard the packaging until everything is removed. Check the packing list below to make sure you have all of the parts and accessories. If any part is missing or broken, please contact customer service at **1-847-429-9263** (M-F 8-5 CST), or email techsupport@wenproducts.com.

Components

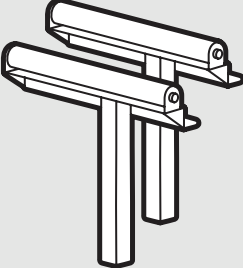

Workpiece Supports with Rollers (2)

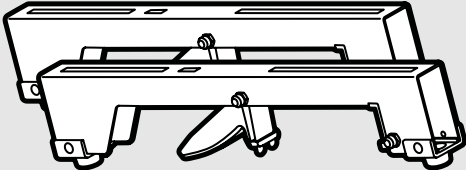

Mounting Brackets (2)



Main Frame (1)



Extension Arms (2)



Lock Knobs (4)

Hardware & Tools



M6 Nuts (4)



6mm Lock Washers (4)



6mm Washers (4)

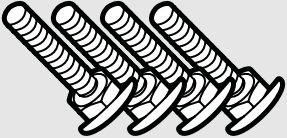

M6x45 Carriage Bolts (4)

KNOW YOUR MITER SAW STAND

TOOL PURPOSE

Miter saw stands adequately support both your miter saw and your workpiece to help you get the job done. Refer to the following diagrams to become familiarized with all the parts and controls of your miter saw stand. The components will be referred to later in the manual for assembly and operation instructions.

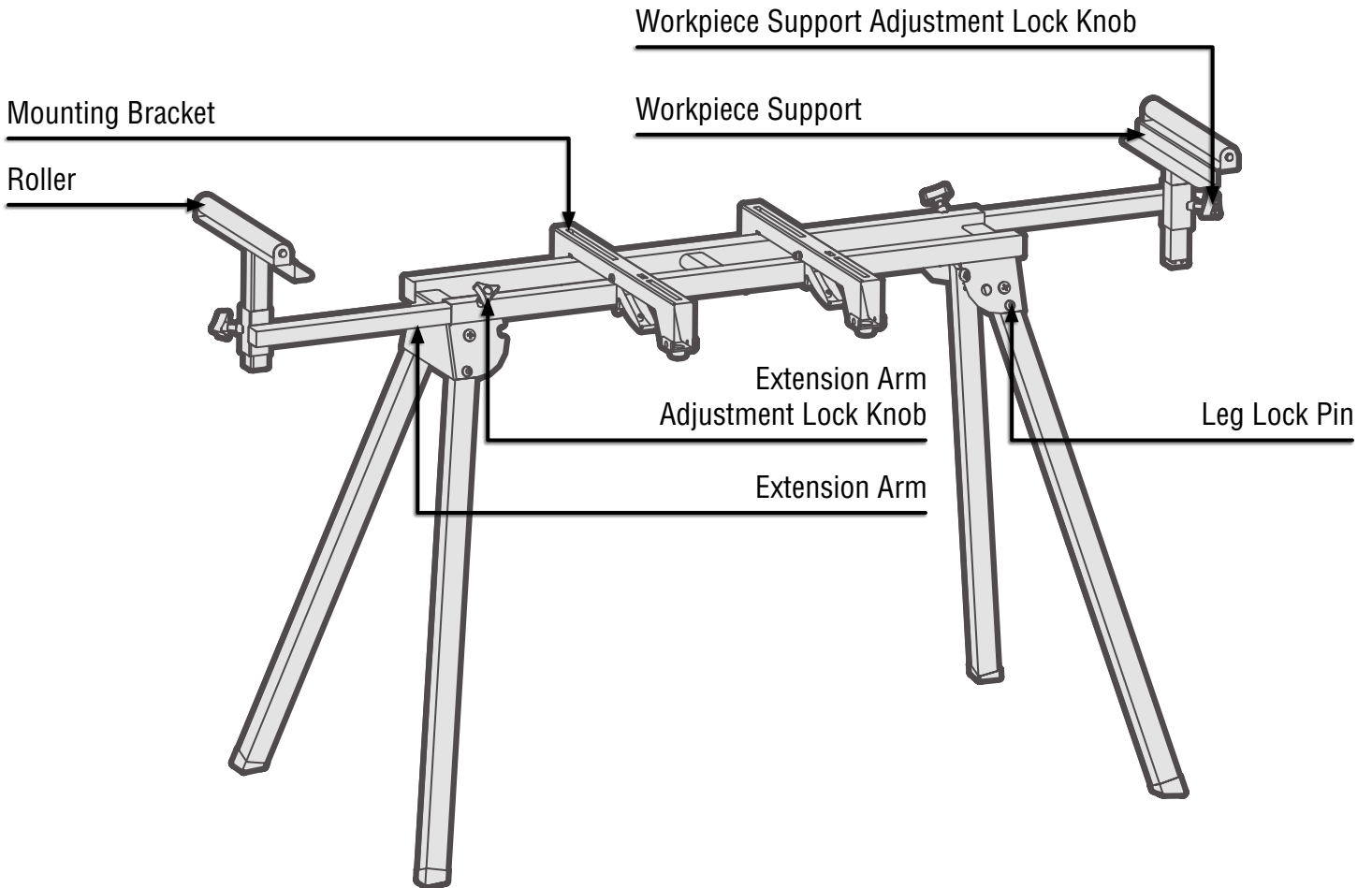

MOUNTING DIMENSIONS

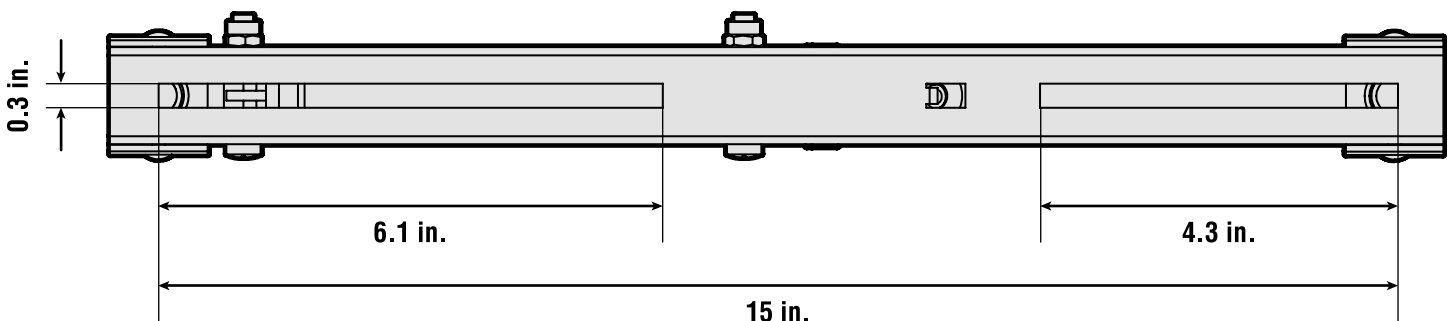

ASSEMBLY & ADJUSTMENTS

UNFOLDING THE LEGS

1. Place the miter saw stand on a flat surface with the folded legs facing up as shown in Fig. 1.
2. Press down on the leg lock pin (Fig. 1 - 1) and rotate the leg (Fig. 1 - 2) up until the locking pin clicks into the open position.
3. Open all four legs and lock them into place.
4. Flip the stand over to the upright position and double check that the stand is stable on the ground.

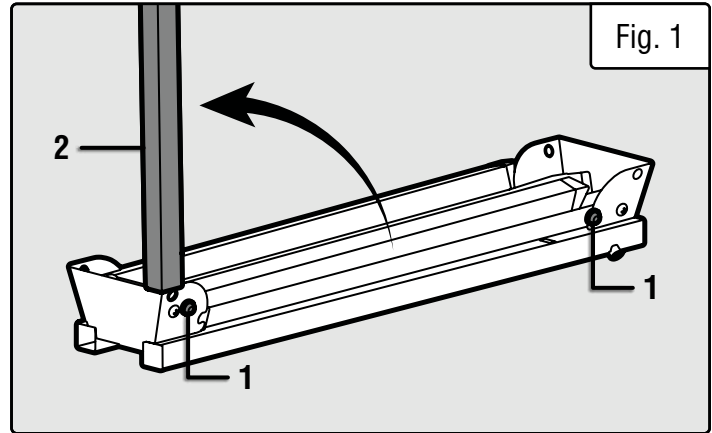

INSTALLING THE EXTENSION ARMS & ROLLERS

1. Insert the workpiece support (Fig. 2 - 1) into the extension bracket on the extension arm (Fig. 2 - 2). Slide the workpiece support to the desired height and secure it with a workpiece support adjustment lock (Fig. 2 - 3). Repeat for the other workpiece support.
2. Insert the extension arm (Fig. 3 - 1) into the main frame. Slide the extension arm to the desired distance and lock the arm in place with an extension arm adjustment lock (Fig. 3 - 2). Repeat for the other extension arm.

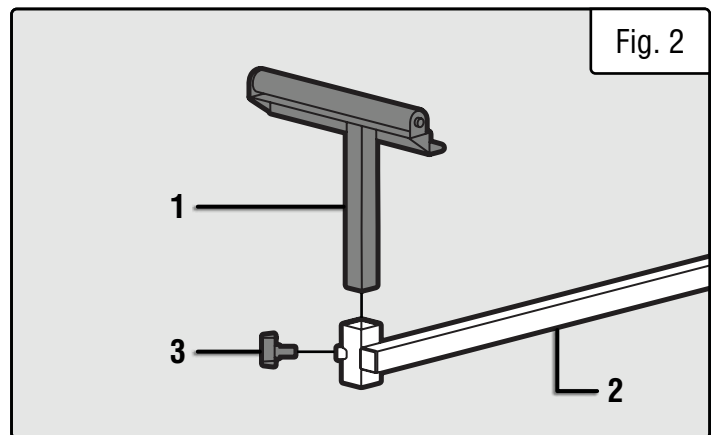

For Normal Cutting Operations

The top of the rollers should be level with the surface of the miter saw's table. This will ensure a level support for your workpiece.

For Repetitive Cutting Operations

Turn the roller so that the workpiece support faces the miter saw. Adjust the height of the roller so that the workpiece stop is level with the surface of the miter saw's table. Adjust the relevant extension arm until the workpiece stop is at the required stopping distance.

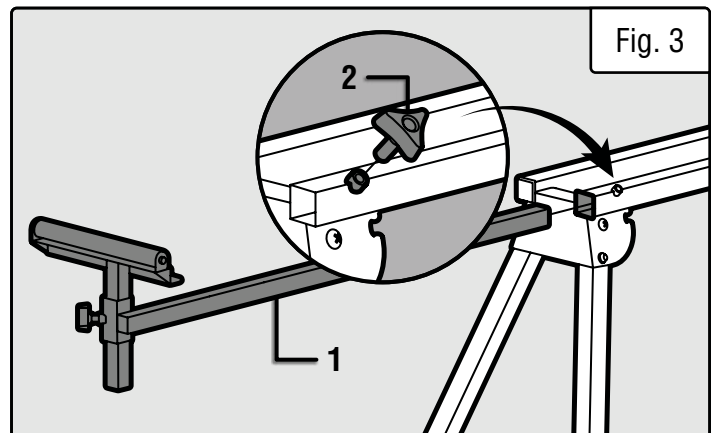

⚠ WARNING! Make sure that the miter saw (not included) is switched OFF and unplugged from the power source before attempting to mount.

MOUNTING THE MITER SAW

1. Attach the miter saw (not included) to the two mounting brackets (Fig. 4 - 1) through the four mounting holes on the saw using the four included carriage bolts (Fig. 4 - 2), flat washers (Fig. 4 - 3), spring washers (Fig. 4 - 4), and nuts (Fig. 4 - 5). Make sure that the mounting bracket levers face the rear of the saw as shown in Fig. 4.

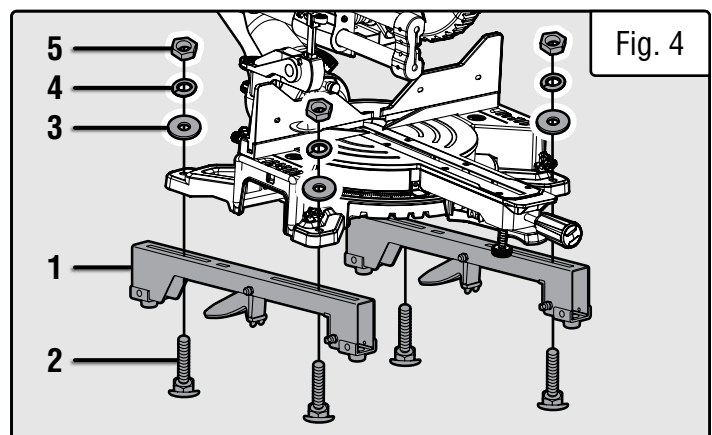

ASSEMBLY & ADJUSTMENTS

MOUNTING THE MITER SAW (CONT.)

⚠ WARNING! To properly secure the miter saw to the mounting brackets, the included carriage bolts must be threaded all the way through the washers and nuts. They also must not interfere with the safe operation of the saw. The included carriage bolts may be too long or too short for your particular miter saw. If needed, replacement carriage bolts can be used, but they must be grade 5, have the same type of head, have a 1.0mm thread pitch, and have a M6 thread diameter.

NOTE: The two mounting brackets must be parallel to each other. If the miter saw does not have at least four mounting holes that line up with the bolts on the mounting bracket, the miter saw will need to be attached using an adaptor plate. See page 10.

NOTE: Be sure that the mounting brackets are installed in the correct orientation. The mounting bracket levers should be facing the front of the saw as shown in Fig. 4.

2. With help, lift the miter saw and mounting brackets onto the main frame.

3. Squeeze the levers (Fig. 5 - 1) on both of the mounting brackets to open them.

4. Align the clamp blocks (Fig. 5 - 2) on the inside of the mounting brackets to the main frame as shown in Fig. 5. Guide the mounting brackets down so that the levers align with the other side of the main frame.

5. Release the levers once everything is aligned with the frame. Releasing the levers will lock the miter saw and mounting brackets onto the main frame.

6. To move the saw, squeeze the levers on both mounting brackets. Slide the saw across the main frame and into its desired position. Once set, release the levers to lock the saw and mounting brackets in place.

7. To remove the saw from the main frame, squeeze the levers on both mounting brackets. The mounting brackets will open, allowing you to lift the saw and mounting brackets off of the stand.

8. Once the saw is positioned on the frame, check that it is fully seated and locked in place before beginning any operations. The clamp blocks should be on the same side of the frame as the operator. Make sure the saw and stand are stable and will not tip over. Test the saw's full range of motion before making any cuts.

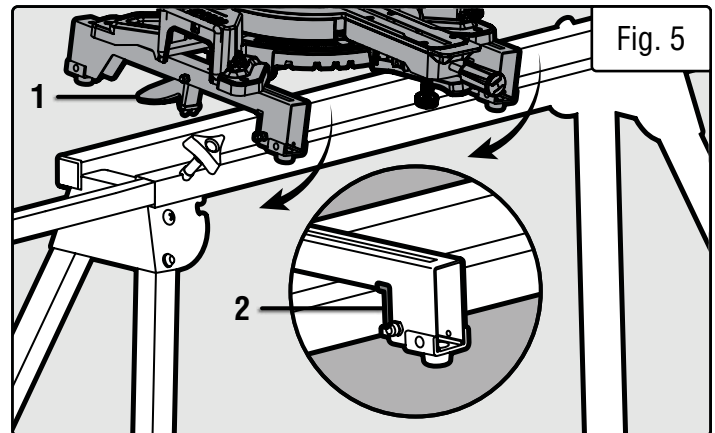

ASSEMBLY & ADJUSTMENTS

MOUNTING UNUSUAL MITER SAWS

If your miter saw is strange or unusual in terms of either its mounting holes or its social skills, don't be alarmed. Every miter saw is special in its own unique way. If you have one of these special miter saws, an adaptor plate may be necessary. The adaptor should be a square or rectangular worktop (such as a piece of plywood) that fits the footprint and mounting hole configuration of your miter saw. We recommend using a piece of plywood at least one inch thick.

1. Bolt the adaptor plate securely to the two saw mounting brackets.
2. Attach the adaptor plate onto the miter saw stand using the saw mounting brackets and lock it in place.
3. Position the miter saw above the adaptor plate. Ensure that the bulk and weight of the miter saw is centrally located over the two crossbars. The saw fence should align as closely as possible with the center line of the miter saw stand's rear crossbar. Bolt the miter saw securely to the adaptor plate with appropriate screws and fixings.
4. Check the stability of the machine and installation before operation.

NOTE: Consult the manufacturer of the saw for any special adjustments, requirements or fixings needed to permanently mount your saw to a worktop. Take precaution over a full range of operating conditions. Don't be judgmental towards your saw for being different than the other saws on the market. You will hurt its feelings.

OPERATION

EXTENSION ARMS

1. To provide support for longer workpieces, loosen the extension arm adjustment locks (Fig. 6 - 1) to unlock the extension arms (Fig. 6 - 2).
2. Extend the extension arms to the desired length. Make sure not to exceed the "MAXIMUM WORKING LENGTH" lines on the extension arms. Doing so is a tipping hazard.
3. Retighten the extension arm adjustment locks to lock the extension arms in place. Make sure the arms are secure before beginning operation.

ROLLERS & WORKPIECE SUPPORTS

1. To adjust the height of the workpiece supports (Fig. 7 - 1), loosen the workpiece support adjustment locks (Fig. 7 - 2) and raise or lower the supports so that they are level with the saw table.

⚠ WARNING! Make sure that the workpiece lays flat on the saw table before beginning operation. The saw blade may bind if the workpiece isn't laying completely flat.

2. Retighten the workpiece support adjustment locks to lock the workpiece supports in place. Make sure the workpiece supports are secure before beginning operation.

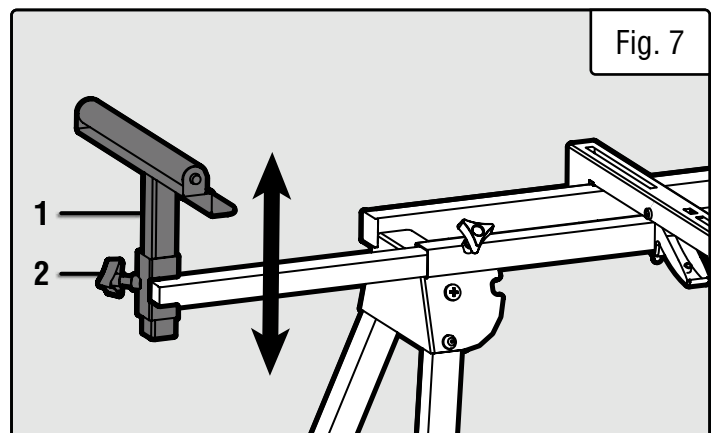
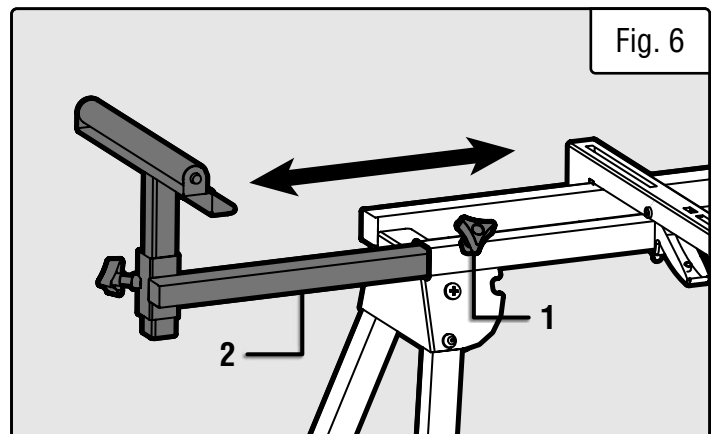

MAINTENANCE

1. Before each use, inspect the general condition of the miter saw stand and miter saw. Check for:
 - Loose hardware
 - Misalignment or binding of moving parts
 - Damaged cord / electrical wiring
 - Cracked or broken parts
 - Any other condition that may affect its safe operation.
2. After every use, wipe the external surfaces with a clean cloth.
3. Store the tool indoors in a safe, dry area away from children. Inspect the tool for good working condition prior to storage and before re-use.

PRODUCT DISPOSAL

The tool, accessories and packaging should be sorted for recycling instead of disposed of with household waste. Please take them to your local recycling facility for responsible disposal and to minimize the environmental impact.



Please recycle the packaging and electronic components where facilities exist. Please contact your local auto garage or recycling facility to properly dispose of oil/fuel.

EXPLODED VIEW & PARTS LIST

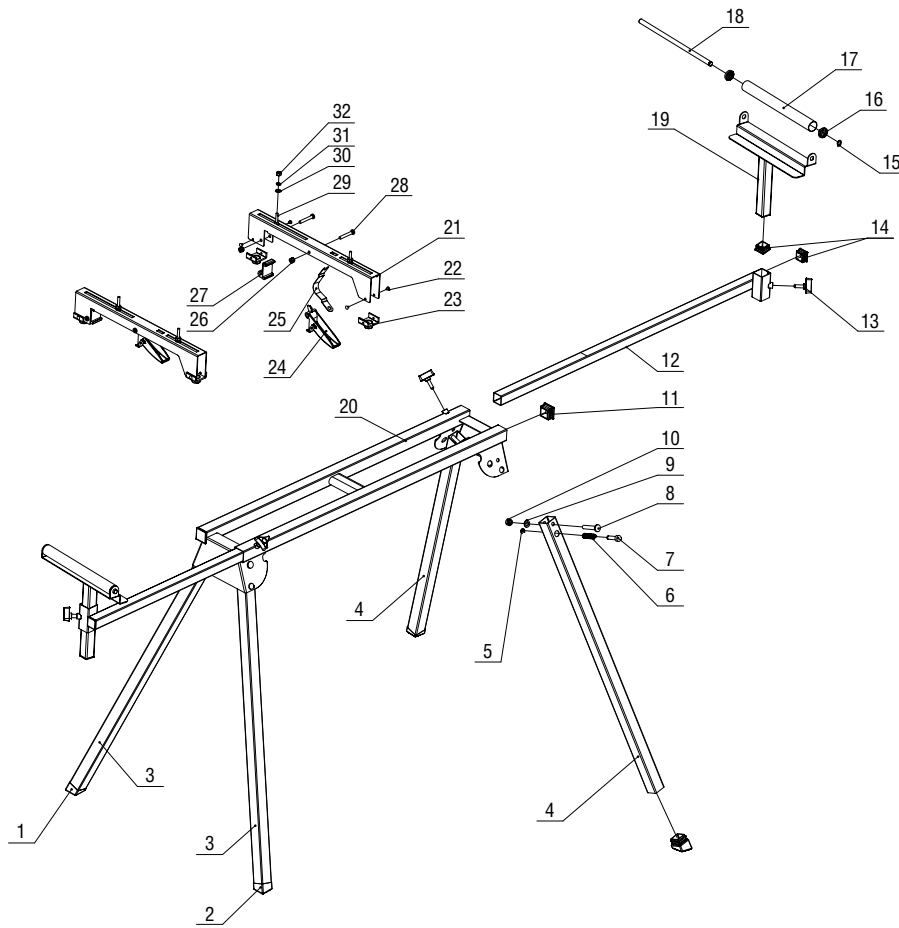

No.	Part No.	Description	Qty.
1	MSA200-001	Rear Leg Cap	2
2	MSA200-002	Front Leg Cap	2
3	MSA200-003	Support Leg 1	2
4	MSA200-004	Support Leg 2	2
5	MSA200-005	Retaining Ring, 6mm	4
6	MSA200-006	Spring	4
7	MSA200-007	Lock Pin	4
8	MSA200-008	Carriage Bolt, M8x45	4
9	MSA200-009	Flat Washer, 8mm	4
10	MSA200-010	Lock Nut, M8	4
11	MSA200-011	Main Beam Cap	2
12	MSA200-012	Extension Arm	2
13	MSA200-013	Lock Knob, M8	4
14	MSA200-014	End Cap	4
15	MSA200-015	Shaft Washer, 10mm	2
16	MSA200-016	Roller Bearing	4
17	MSA200-017	Roller	2

No.	Part No.	Description	Qty.
18	MSA200-018	Roller Shaft	2
19	MSA200-019	Workpiece Support	2
20	MSA200-020	Main Frame	1
21	MSA200-021	Mounting Bracket	2
22	MSA200-022	Core Rivet	8
23	MSA200-023	Mounting Bracket Cap	4
24	MSA200-024	Mounting Bracket Lever	2
25	MSA200-025	Leaf Spring	2
26	MSA200-026	Lock Nut, M6	4
27	MSA200-027	Clamping Block	2
28	MSA200-028	Phillips-head Screw, M6x37	4
29	MSA200-029	Carriage Bolt, M6x45	4
30	MSA200-030	Flat Washer, 6 x 20 x 2	4
31	MSA200-031	Lock Washer, 6mm	4
32	MSA200-032	Nut, M6	4

WARRANTY STATEMENT

WEN Products is committed to building tools that are dependable for years. Our warranties are consistent with this commitment and our dedication to quality.

LIMITED WARRANTY OF WEN PRODUCTS FOR HOME USE

GREAT LAKES TECHNOLOGIES, LLC (“Seller”) warrants to the original purchaser only, that all WEN consumer power tools will be free from defects in material or workmanship during personal use for a period of two (2) years from date of purchase or 500 hours of use; whichever comes first. Ninety days for all WEN products if the tool is used for professional or commercial use. Purchaser has 30 days from the date of purchase to report missing or damaged parts.

SELLER’S SOLE OBLIGATION AND YOUR EXCLUSIVE REMEDY under this Limited Warranty and, to the extent permitted by law, any warranty or condition implied by law, shall be the replacement of parts, without charge, which are defective in material or workmanship and which have not been subjected to misuse, alteration, careless handling, misrepair, abuse, neglect, normal wear and tear, improper maintenance, or other conditions adversely affecting the Product or the component of the Product, whether by accident or intentionally, by persons other than Seller. To make a claim under this Limited Warranty, you must make sure to keep a copy of your proof of purchase that clearly defines the Date of Purchase (month and year) and the Place of Purchase. Place of Purchase must be a direct vendor of Great Lakes Technologies, LLC. Purchasing through third party vendors, including but not limited to garage sales, pawn shops, resale shops, or any other secondhand merchant, voids the warranty included with this product. Contact techsupport@wenproducts.com or 1-800-232-1195 with the following information to make arrangements: your shipping address, phone number, serial number, required part numbers, and proof of purchase. Damaged or defective parts and products may need to be sent to WEN before the replacements can be shipped out.

Upon the confirmation of a WEN representative, your product may qualify for repairs and service work. When returning a product for warranty service, the shipping charges must be prepaid by the purchaser. The product must be shipped in its original container (or an equivalent), properly packed to withstand the hazards of shipment. The product must be fully insured with a copy of the proof of purchase enclosed. There must also be a description of the problem in order to help our repairs department diagnose and fix the issue. Repairs will be made and the product will be returned and shipped back to the purchaser at no charge for addresses within the contiguous United States.

THIS LIMITED WARRANTY DOES NOT APPLY TO ITEMS THAT WEAR OUT FROM REGULAR USAGE OVER TIME, INCLUDING BELTS, BRUSHES, BLADES, BATTERIES, ETC. ANY IMPLIED WARRANTIES SHALL BE LIMITED IN DURATION TO TWO (2) YEARS FROM DATE OF PURCHASE. SOME STATES IN THE U.S. AND SOME CANADIAN PROVINCES DO NOT ALLOW LIMITATIONS ON HOW LONG AN IMPLIED WARRANTY LASTS, SO THE ABOVE LIMITATION MAY NOT APPLY TO YOU.

IN NO EVENT SHALL SELLER BE LIABLE FOR ANY INCIDENTAL OR CONSEQUENTIAL DAMAGES (INCLUDING BUT NOT LIMITED TO LIABILITY FOR LOSS OF PROFITS) ARISING FROM THE SALE OR USE OF THIS PRODUCT. SOME STATES IN THE U.S. AND SOME CANADIAN PROVINCES DO NOT ALLOW THE EXCLUSION OR LIMITATION OF INCIDENTAL OR CONSEQUENTIAL DAMAGES, SO THE ABOVE LIMITATION OR EXCLUSION MAY NOT APPLY TO YOU.

THIS LIMITED WARRANTY GIVES YOU SPECIFIC LEGAL RIGHTS, AND YOU MAY ALSO HAVE OTHER RIGHTS WHICH VARY FROM STATE TO STATE IN THE U.S., PROVINCE TO PROVINCE IN CANADA AND FROM COUNTRY TO COUNTRY.

THIS LIMITED WARRANTY APPLIES ONLY TO ITEMS SOLD WITHIN THE UNITED STATES OF AMERICA, CANADA AND THE COMMONWEALTH OF PUERTO RICO. FOR WARRANTY COVERAGE WITHIN OTHER COUNTRIES, CONTACT THE WEN CUSTOMER SUPPORT LINE. FOR WARRANTY PARTS OR PRODUCTS REPAIRED UNDER WARRANTY SHIPPING TO ADDRESSES OUTSIDE OF THE CONTIGUOUS UNITED STATES, ADDITIONAL SHIPPING CHARGES MAY APPLY.

**THANKS FOR
REMEMBERING**  [®]