

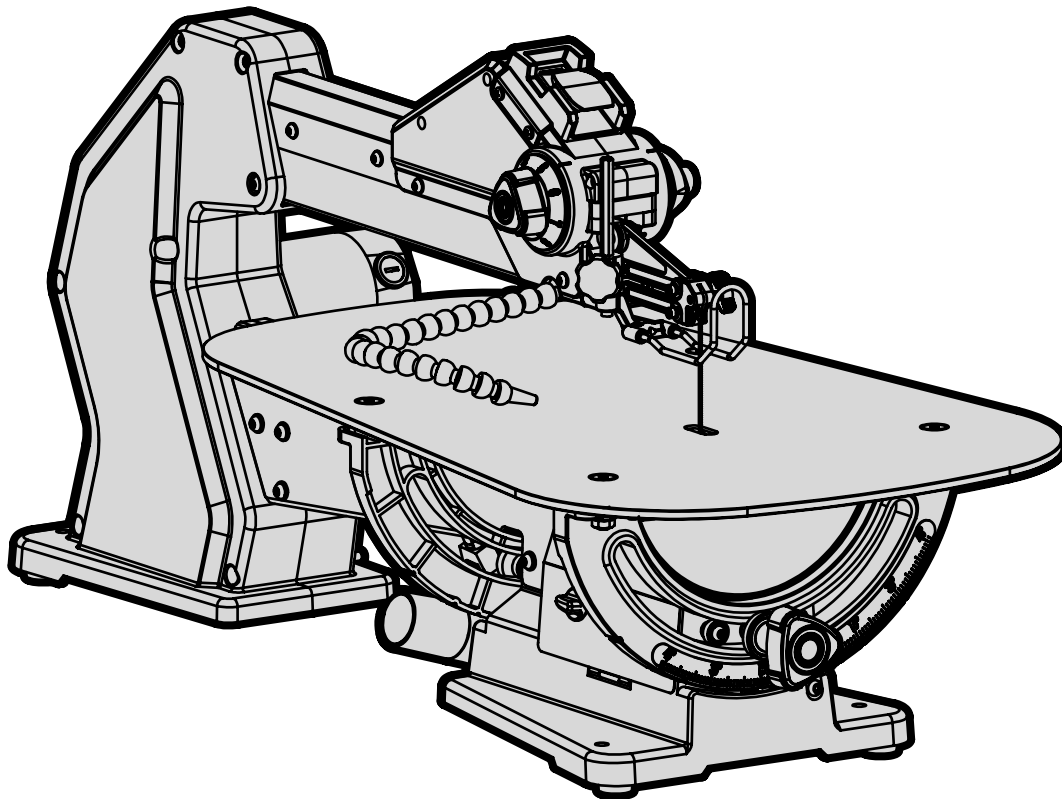

MODEL LL2156

21-INCH SCROLL SAW

Instruction Manual



NEED HELP? CONTACT US!

Have product questions? Need technical support? Please feel free to contact us:



1-800-232-1195 (M-F 8AM-5PM CST)



TECHSUPPORT@WENPRODUCTS.COM

IMPORTANT: Your new tool has been engineered and manufactured to WEN's highest standards for dependability, ease of operation, and operator safety. When properly cared for, this product will supply you years of rugged, trouble-free performance. Pay close attention to the rules for safe operation, warnings, and cautions. If you use your tool properly and for its intended purpose, you will enjoy years of safe, reliable service.

For replacement parts and the most up-to-date instruction manuals, visit ***WENPRODUCTS.COM***

CONTENTS

WELCOME	3
Introduction	3
Specifications.....	3
SAFETY	4
General Safety Rules	4
Scroll Saw Safety Warnings	6
Electrical Information	7
BEFORE OPERATING	8
Unpacking & Packing List	8
Know Your Scroll Saw	9
Preparation	9
Assembly & Adjustments	10
OPERATION & MAINTENANCE	14
Operation	14
Maintenance.....	18
Troubleshooting Guide	20
Exploded View & Parts List	21
Warranty Statement	24

To purchase accessories and replacement blades for your tool, visit ***WENPRODUCTS.COM***

120V 15-Amp Momentary Power Foot Pedal Switch (Model WA0392)

INTRODUCTION

Thanks for purchasing the WEN Scroll Saw. We know you are excited to put your tool to work, but first, please take a moment to read through the manual. Safe operation of this tool requires that you read and understand this operator's manual and all the labels affixed to the tool. This manual provides information regarding potential safety concerns, as well as helpful assembly and operating instructions for your tool.

 Indicates danger, warning, or caution. The safety symbols and the explanations with them deserve your careful attention and understanding. Always follow the safety precautions to reduce the risk of fire, electric shock or personal injury. However, please note that these instructions and warnings are not substitutes for proper accident prevention measures.

NOTE: The following safety information is not meant to cover all possible conditions and situations that may occur. WEN reserves the right to change this product and specifications at any time without prior notice.

At WEN, we are continuously improving our products. If you find that your tool does not exactly match this manual, please visit wenproducts.com for the most up-to-date manual or contact our customer service at **1-800-232-1195**.

Keep this manual available to all users during the entire life of the tool and review it frequently to maximize safety for both yourself and others.

SPECIFICATIONS

Model Number	LL2156
Motor	120V, 60 Hz, S1 1.2A, S2 30 min 1.6A
Speed	550 - 1600 SPM
Throat Depth	21 Inches
Maximum Workpiece Thickness	2 in. at 0°
	3/4 in. at 45°
Blade Stroke	3/4 Inch
Table Bevel	0° - 45° Left, 0° - 30° Right
Table Size	25-5/8 in. x 16 in.
Blade Type	5 Inches, Pinless
Dust Port Adapter	1-1/2 in. Outer Diam., 1-5/16 in. Inner Diam.
Dimensions	36-1/2 in. x 16 in. x 17-3/4 in.
Weight	53.8 Pounds

GENERAL SAFETY RULES

 **WARNING!** Read all safety warnings and all instructions. Failure to follow the warnings and instructions may result in electric shock, fire and/or serious injury.

Safety is a combination of common sense, staying alert and knowing how your item works. The term “power tool” in the warnings refers to your mains-operated (corded) power tool or battery-operated (cordless) power tool.

SAVE THESE SAFETY INSTRUCTIONS.

WORK AREA SAFETY

- 1. Keep work area clean and well lit.** Cluttered or dark areas invite accidents.
- 2. Do not operate power tools in explosive atmospheres, such as in the presence of flammable liquids, gases or dust.** Power tools create sparks which may ignite the dust or fumes.
- 3. Keep children and bystanders away while operating a power tool.** Distractions can cause you to lose control.

ELECTRICAL SAFETY

- 1. Power tool plugs must match the outlet. Never modify the plug in any way. Do not use any adapter plugs with earthed (grounded) power tools.** Unmodified plugs and matching outlets will reduce risk of electric shock.
- 2. Avoid body contact with earthed or grounded surfaces such as pipes, radiators, ranges and refrigerators.** There is an increased risk of electric shock if your body is earthed or grounded.
- 3. Do not expose power tools to rain or wet conditions.** Water entering a power tool will increase the risk of electric shock.
- 4. Do not abuse the cord. Never use the cord for carrying, pulling or unplugging the power tool. Keep cord away from heat, oil, sharp edges or moving parts.** Damaged or entangled cords increase the risk of electric shock.
- 5. When operating a power tool outdoors, use an extension cord suitable for outdoor use.** Use of a cord suitable for outdoor use reduces the risk of electric shock.

- 6. If operating a power tool in a damp location is unavoidable, use a ground fault circuit interrupter (GFCI) protected supply.** Use of a GFCI reduces the risk of electric shock.

PERSONAL SAFETY

- 1. Stay alert, watch what you are doing and use common sense when operating a power tool. Do not use a power tool while you are tired or under the influence of drugs, alcohol or medication.** A moment of inattention while operating power tools may result in serious personal injury.
- 2. Use personal protective equipment. Always wear eye protection.** Protective equipment such as a respiratory mask, non-skid safety shoes and hearing protection used for appropriate conditions will reduce the risk of personal injury.
- 3. Prevent unintentional starting. Ensure the switch is in the off-position before connecting to power source and/or battery pack, picking up or carrying the tool.** Carrying power tools with your finger on the switch or energizing power tools that have the switch on invites accidents.
- 4. Remove any adjusting key or wrench before turning the power tool on.** A wrench or a key left attached to a rotating part of the power tool may result in personal injury.
- 5. Do not overreach. Keep proper footing and balance at all times.** This enables better control of the power tool in unexpected situations.
- 6. Dress properly. Do not wear loose clothing or jewelry. Keep your hair and clothing away from moving parts.** Loose clothes, jewelry or long hair can be caught in moving parts.

GENERAL SAFETY RULES

⚠ WARNING! Read all safety warnings and all instructions. Failure to follow the warnings and instructions may result in electric shock, fire and/or serious injury.

Safety is a combination of common sense, staying alert and knowing how your item works. The term “power tool” in the warnings refers to your mains-operated (corded) power tool or battery-operated (cordless) power tool.

SAVE THESE SAFETY INSTRUCTIONS.

7. If devices are provided for the connection of dust extraction and collection facilities, ensure these are connected and properly used. Use of dust collection can reduce dust-related hazards.

POWER TOOL USE AND CARE

1. Do not force the power tool. Use the correct power tool for your application. The correct power tool will do the job better and safer at the rate for which it was designed.

2. Do not use the power tool if the switch does not turn it on and off. Any power tool that cannot be controlled with the switch is dangerous and must be repaired.

3. Disconnect the plug from the power source and/or the battery pack from the power tool before making any adjustments, changing accessories, or storing power tools. Such preventive safety measures reduce the risk of starting the power tool accidentally.

4. Store idle power tools out of the reach of children and do not allow persons unfamiliar with the power tool or these instructions to operate the power tool. Power tools are dangerous in the hands of untrained users.

5. Maintain power tools. Check for misalignment or binding of moving parts, breakage of parts and any other condition that may affect the power tool's operation. If damaged, have the power tool repaired before use. Many accidents are caused by poorly maintained power tools.

6. Keep cutting tools sharp and clean. Properly maintained cutting tools with sharp cutting edges are less likely to bind and are easier to control.

7. Use the power tool, accessories and tool bits, etc. in accordance with these instructions, taking into account the working conditions and the work to be performed. Use of the power tool for operations different from those intended could result in a hazardous situation.

8. Use clamps to secure your workpiece to a stable surface. Holding a workpiece by hand or using your body to support it may lead to loss of control.

9. KEEP GUARDS IN PLACE and in working order.

SERVICE

1. Have your power tool serviced by a qualified repair person using only identical replacement parts. This will ensure that the safety of the power tool is maintained.

CALIFORNIA PROPOSITION 65 WARNING

Some dust created by power sanding, sawing, grinding, drilling, and other construction activities may contain chemicals, including lead, known to the State of California to cause cancer, birth defects, or other reproductive harm. Wash hands after handling. Some examples of these chemicals are:

- Lead from lead-based paints.
- Crystalline silica from bricks, cement, and other masonry products.
- Arsenic and chromium from chemically treated lumber.

Your risk from these exposures varies depending on how often you do this type of work. To reduce your exposure to these chemicals, work in a well-ventilated area with approved safety equipment such as dust masks specially designed to filter out microscopic particles.

SCROLL SAW SAFETY WARNINGS

 **WARNING!** Do not operate the power tool until you have read and understood the following instructions and the warning labels.

BEFORE OPERATION

1. Check for both proper assembly and proper alignment of moving parts.

2. Understand the proper use of the ON / OFF switch.

3. Know the condition of the scroll saw. If any part is missing, bent, or does not operate properly, replace the component before attempting to operate the scroll saw.

4. Determine the type of work you are going to be doing. Properly protect your body including your eyes, hands, face, and ears.

5. To avoid injury caused by pieces thrown from accessories, use only recommended accessories designed for this saw. Follow the instructions supplied with the accessory. The use of improper accessories may cause risk of injury.

6. To avoid contact with rotating equipment:

- Do not put your fingers in a position where they risk contacting the blade if the workpiece unexpectedly shifts or your hand unexpectedly slips.

- Do not cut a workpiece too small to be held safely.

- Do not reach under the scroll saw table when the motor is running.

- Do not wear loose clothing or jewelry. Roll long sleeves above the elbow. Tie back long hair.

7. To avoid injury from accidental startups of the scroll saw:

- Make sure to turn OFF the switch and unplug the power cord from the electric outlet before changing the blade, performing maintenance or making adjustments.

- Make sure the switch is OFF before plugging in the power cord to an electric outlet.

8. To avoid injury from a fire hazard, do not operate the scroll saw near flammable liquids, vapors or gases.

9. To avoid back injury:

- Obtain help when raising the scroll saw more than 10 inches (25.4 cm). Bend your knees when lifting the scroll saw.

- Carry the scroll saw by its base. Do not move the scroll saw by pulling on the power cord. Pulling on the power cord could cause damage to the insulation or the wire connections resulting in electric shock or fire.

SCROLL SAW SAFETY

1. To avoid injury from unexpected saw movement:

- Use the scroll saw on a firm level surface with adequate space for handling and supporting the workpiece.

- Be sure the scroll saw cannot move when operated. Secure the scroll saw to a workbench or table with wood screws or bolts, washers and nuts.

2. Before moving the scroll saw, unplug the power cord from the electrical outlet.

3. To avoid injury from kickback:

- Hold the workpiece firmly against the tabletop.

- Do not feed the workpiece too fast while cutting. Only feed the workpiece at the rate the saw will cut.

- Install the blade with the teeth pointing downward.

- Do not start the saw with the workpiece pressing against the blade. Slowly feed the workpiece into the moving blade.

- Use caution when cutting round or irregularly shaped workpieces. Round items will roll and irregularly shaped workpieces can pinch the blade.

4. To avoid injury when operating the scroll saw:

- Obtain advice from a qualified person if you're not thoroughly familiar with the operation of scroll saws.

- Before starting the saw, make sure the blade tension is correct. Recheck and adjust tension as needed.

- Make sure the table is locked into position before starting the saw.

- Do not use dull or bent blades.

- When cutting a large workpiece, make sure the material is supported at the table height.

- Turn the saw OFF and unplug the power cord if the blade jams in the workpiece. This condition is usually caused by sawdust clogging the line you are cutting. Wedge open the workpiece and back out the blade after turning off and unplugging the machine.

ELECTRICAL INFORMATION

GROUNDING INSTRUCTIONS

In the event of a malfunction or breakdown, grounding provides the path of least resistance for an electric current and reduces the risk of electric shock. This tool is equipped with an electric cord that has an equipment grounding conductor and a grounding plug. The plug **MUST** be plugged into a matching outlet that is properly installed and grounded in accordance with ALL local codes and ordinances.

1. Do not modify the plug provided. If it will not fit the outlet, have the proper outlet installed by a licensed electrician.

2. Improper connection of the equipment grounding conductor can result in electric shock. The conductor with the green insulation (with or without yellow stripes) is the equipment grounding conductor. If repair or replacement of the electric cord or plug is necessary, **DO NOT** connect the equipment grounding conductor to a live terminal.

3. Check with a licensed electrician or service personnel if you do not completely understand the grounding instructions or whether the tool is properly grounded.

4. Use only three-wire extension cords that have three-pronged plugs and outlets that accept the tool's plug. Repair or replace a damaged or worn cord immediately.

CAUTION! In all cases, make certain the outlet in question is properly grounded. If you are not sure, have a licensed electrician check the outlet.

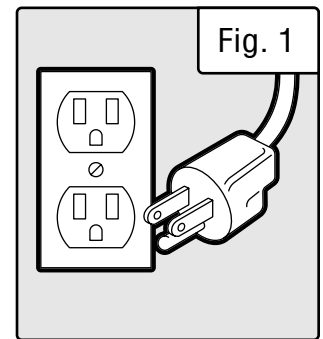

GUIDELINES AND RECOMMENDATIONS FOR EXTENSION CORDS

When using an extension cord, be sure to use one heavy enough to carry the current your product will draw. An undersized cord will cause a drop in line voltage resulting in loss of power and overheating. The table below shows the correct size to be used according to cord length and ampere rating. When in doubt, use a heavier cord. The smaller the gauge number, the heavier the cord.

AMPERAGE	REQUIRED GAUGE FOR EXTENSION CORDS			
	25 ft.	50 ft.	100 ft.	150 ft.
1.2A	18 gauge	16 gauge	16 gauge	14 gauge

1. Examine extension cord before use. Make sure your extension cord is properly wired and in good condition. Always replace a damaged extension cord or have it repaired by a qualified person before using it.

2. Do not abuse extension cord. Do not pull on cord to disconnect from receptacle; always disconnect by pulling on plug. Disconnect the extension cord from the receptacle before disconnecting the product from the extension cord. Protect your extension cords from sharp objects, excessive heat and damp/wet areas.

3. Use a separate electrical circuit for your tool. This circuit must not be less than a 12-gauge wire and should be protected with a 15A time-delayed fuse. Before connecting the motor to the power line, make sure the switch is in the OFF position and the electric current is rated the same as the current stamped on the motor nameplate. Running at a lower voltage will damage the motor.

UNPACKING & PACKING LIST

UNPACKING

With the help of a friend or trustworthy foe, such as one of your in-laws, carefully remove the scroll saw from the packaging and place it on a sturdy, flat surface. Make sure to take out all contents and accessories. Do not discard the packaging until everything is removed. Check the packing list below to make sure you have all of the parts and accessories. If any part is missing or broken, please contact customer service at **1-800-232-1195** (M-F 8-5 CST), or email techsupport@wenproducts.com.

⚠ CAUTION! Do not lift the saw by the upper arm. The saw will be damaged. Lift the saw by the table and back housing.

⚠ WARNING! To avoid injury from accidental startups, turn switch OFF and remove the plug from the power source before making any adjustments.

Components

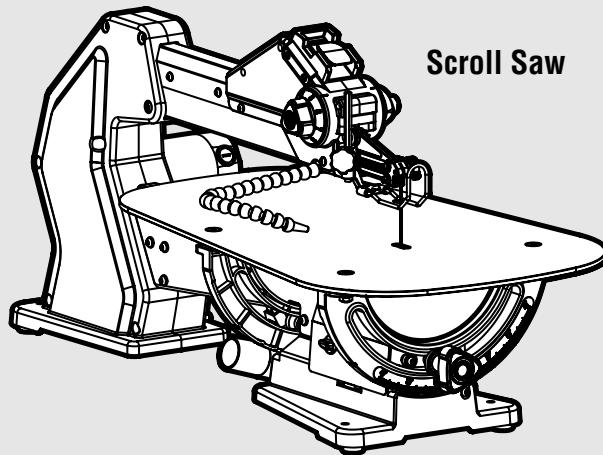

Accessories

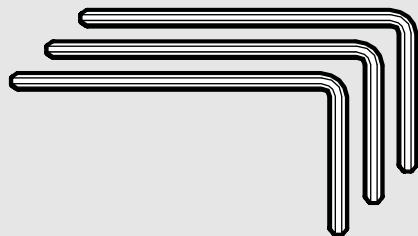

Hex Wrenches (2.5mm, 3mm, 4mm) (3)



15 TPI Pinless Blade
(Assembled on the saw)



18 TPI Pinless Blade

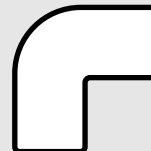

Dust Port Adapter (1)

KNOW YOUR SCROLL SAW

TOOL PURPOSE

Let the good times scroll! Take on the most intricate and artful cuts with your WEN Scroll Saw. Refer to the following diagrams to become familiarized with all the parts and controls of your scroll saw. The components will be referred to later in the manual for assembly and operation instructions.

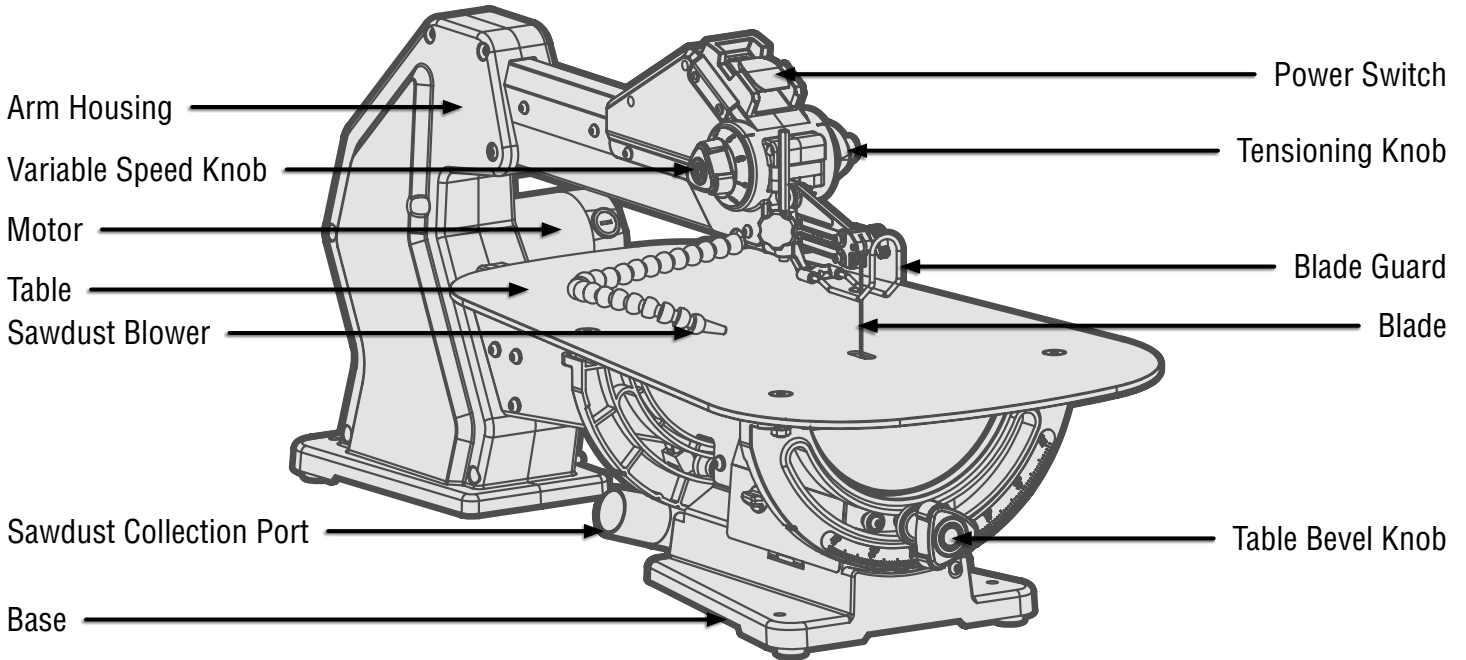

PREPARATION

PREPARING THE SAW

Your saw comes with a light protective coating of machine oil to guard against rust. Wipe off the coating with a soft cloth. If desired, apply a light coat of good-quality paste wax (not included) to the table. This will reduce friction and make your workpieces easy to maneuver.

ASSEMBLY & ADJUSTMENTS

NOTE: Prior to making adjustments, mount the scroll saw on a stable surface. See “Bench mounting the saw.”

ALIGN THE BEVEL INDICATOR

The bevel indicator has been adjusted at the factory, but should be rechecked prior to use for best operation.

1. Loosen the blade guard knob (Fig. 2 - 1) and move the blade guard (Fig. 2 -2) all the way up.
2. Loosen the table bevel lock knob (Fig. 3 - 1) and bevel the table until it is approximately at a right angle to the blade.
3. Use a combination square (Fig. 4 - 1) to set the table exactly 90° to the blade (Fig. 4 - 2). If there is space between the square and blade, adjust the table angle until the space is closed. You may feel the 0-degree table detent engage.
4. Tighten the table bevel lock knob (Fig. 3 - 1).
5. Loosen the screw (Fig. 3 - 2) holding the bevel scale pointer and position pointer to 0°. Tighten the screw.
6. Lower the blade guard foot.

BENCH MOUNTING THE SAW

Before operating the saw, it must be firmly mounted to a workbench or another rigid frame. Use the base of the saw to mark and pre-drill the mounting holes on the mounting surface. If the saw is to be used in one location, permanently secure it to the work surface. Use wood screws if mounting to wood. Use bolts, washers, and nuts if mounting into metal. To reduce noise and vibration, install a soft foam pad (not supplied) between the scroll saw and the workbench.

NOTE: Mounting hardware is not included.

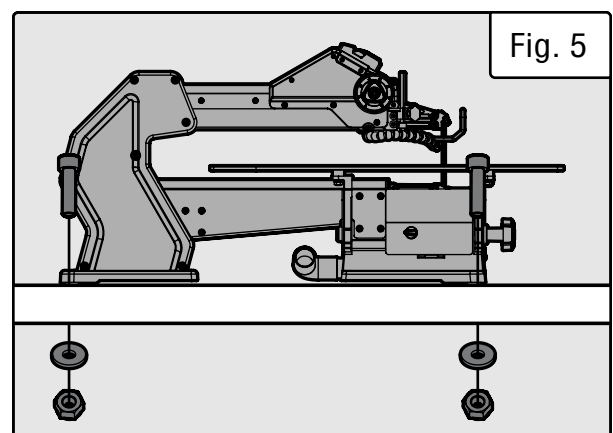
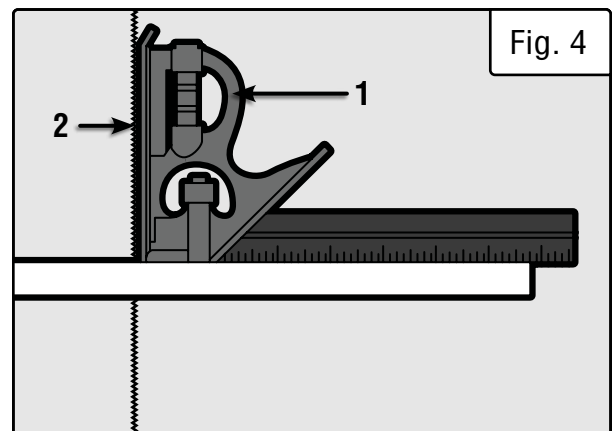
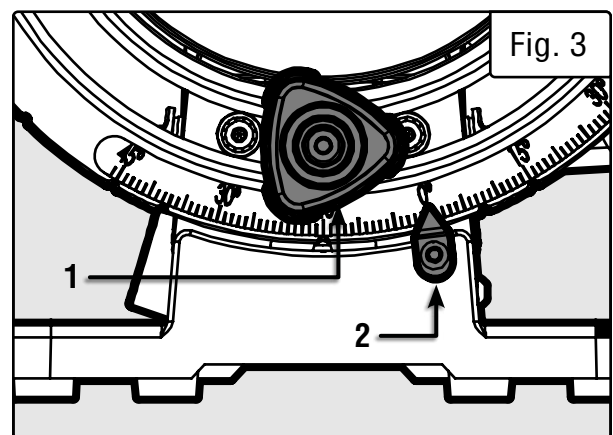
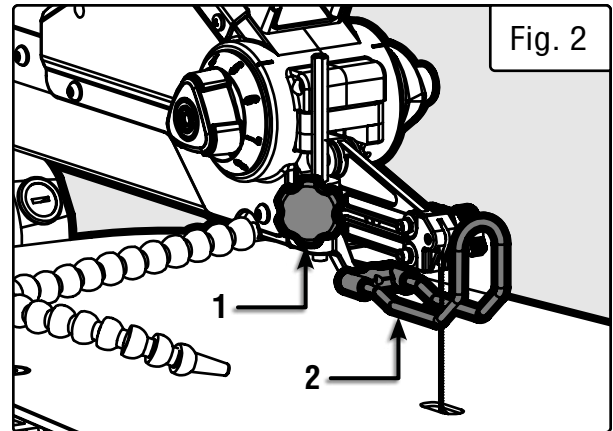

ASSEMBLY & ADJUSTMENTS

⚠ WARNING! TO REDUCE RISK OF INJURY:

- When carrying the saw, hold it close to your body to avoid injury to your back. Bend your knees when lifting the saw.
- Carry the saw by the base, table, housing, or motor. Do not carry the saw by the power cord or upper arm.
- Secure the saw in a position where people cannot stand, sit, or walk behind it. Debris thrown from the saw could injure people standing, sitting, or walking behind it. Secure the saw on a firm, level surface where the saw cannot rock. Make sure there is adequate room for handling and properly supporting the workpiece.

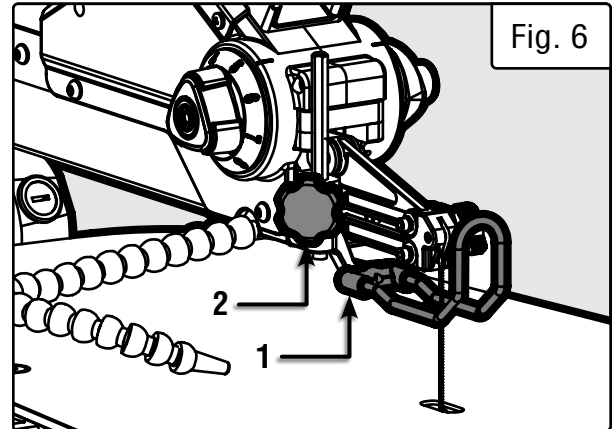

BLADE GUARD FOOT ADJUSTMENT

When cutting at angles, the blade guard foot should be adjusted so it is parallel to the table and rests just above the workpiece.

1. To adjust, use a hex wrench to loosen the screw on the back of the blade guard foot (Fig. 6 - 1), tilt the foot so it is parallel to the table, and tighten the screw.
2. Loosen the blade guard knob (Fig. 6 - 2) to raise or lower the foot until it just rests on top of the workpiece. Tighten the knob.

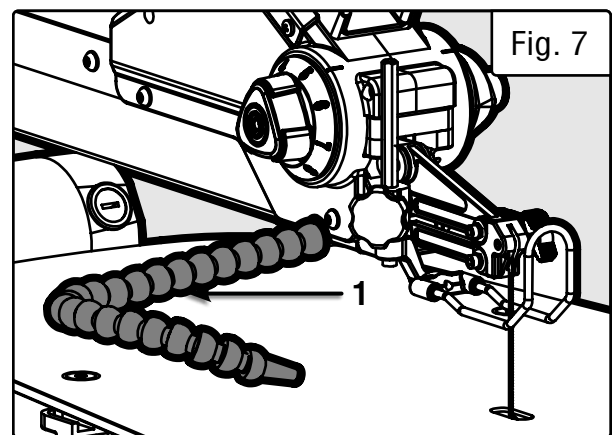

ADJUSTING THE DUST BLOWER

For best results, the dust blower tube (Fig. 7 - 1) should be adjusted to direct air at both the blade and the workpiece.

DUST COLLECTION PORT

A hose or vacuum accessory (not provided) should be connected to the dust port adapter (Fig. 8 - 1). Push the short end of the dust port adapter onto the dust port at the rear of the saw base. If excessive sawdust buildup occurs inside the base, use a wet/dry vacuum cleaner or manually remove sawdust by unlocking both side panel knobs and opening the side panels. Once the sawdust is removed, close the side panels and re-lock both knobs to ensure safe and efficient cutting. The outer diameter of the dust port adapter is 1-1/2 inches; the inner diameter is 1-5/16 inches.

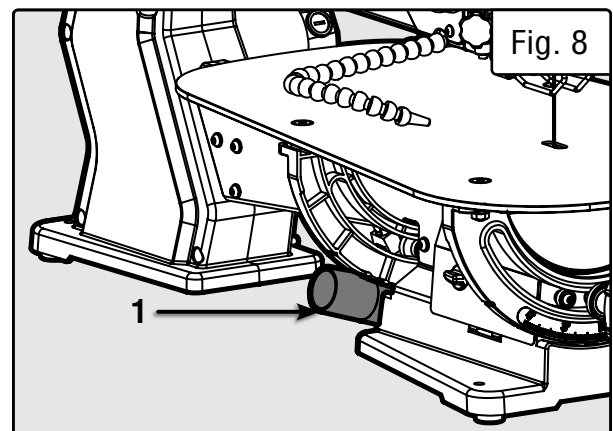

ASSEMBLY & ADJUSTMENTS

BLADE SELECTION

This scroll saw accepts 5" pinless blades, with a wide variety of blade thicknesses and widths. The type of material and intricacies of cutting operations will determine the number of teeth per inch. Always select the narrowest blades for intricate curve cutting and the widest blades for straight and large curve cutting operations. The table below represents suggestions for various materials. Use this table as an example, but with practice, personal preference will be the best selection method.

When choosing a blade, use very fine, narrow blades to scroll cut in thin wood 1/4" thick or less.

Use wider blades for thicker materials.

NOTE: This will reduce the ability to cut tight curves. A smaller blade width can cut circles with smaller diameters.

NOTE: Thinner blades will tend to deflect more when making bevel cuts.

Teeth per Inch	Blade Width	Blade Thickness	Blade SPM	Material Cut
10 to 15	0.11"	0.018"	550 to 1200 SPM	Medium turns on 1/4" to 1-3/4" wood, soft metal, hardwood
15 to 28	0.055" to 0.11"	0.01" to 0.018"	800 to 1600 SPM	Small turns on 1/8" to 1-1/2" wood, soft metal, hardwood

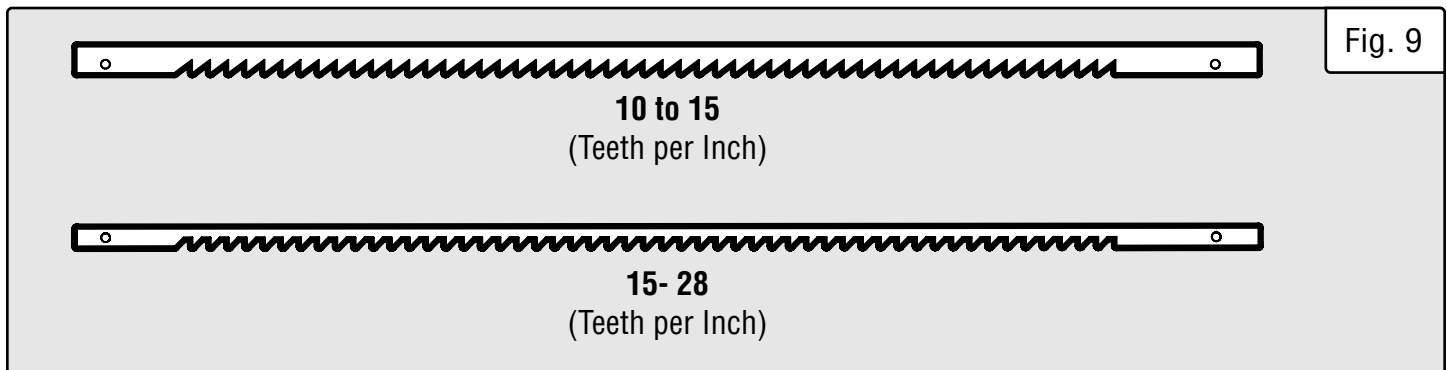

BLADE CARE

To maximize the life of your scroll saw blades:

1. Do not bend blades when installing.
2. Always set proper blade tension.
3. Use the right blade (see instruction on replacement blade packaging for proper use).
4. Feed the work correctly into the blade.
5. Use thin blades for intricate cutting.

CAUTION! Any and all servicing should be performed by a qualified service center.

WARNING! To prevent personal injury, always turn saw OFF and disconnect the plug from the power source before changing blades or making adjustments.

ASSEMBLY & ADJUSTMENTS

This saw uses 5" pinless blades.

REMOVING THE BLADE

Make sure the saw is turned OFF and unplugged before making any adjustments to the blade.

1. To remove the blade, rotate the tension knob (Fig. 10 - 1) toward you to relieve tension. Make sure the knob indicates tension setting 1.
2. Open the right side panel (Fig. 10 - 2).
3. Loosen the top (Fig. 11 - 1), then the bottom blade locking knob (Fig. 11 - 2). Remove the blade.

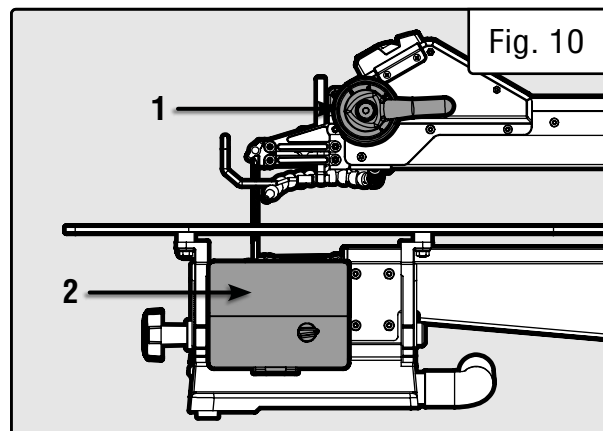

INSTALLING THE BLADE

Make sure the saw is turned OFF and unplugged before making any adjustments to the blade.

1. With the blade's teeth facing toward you and pointing down, thread the new blade through the table slot so that its bottom rests in the bottom clamp.

TIP: There is a clear shield below the table to let you see the bottom clamp better when installing a blade.

2. Tighten the bottom blade locking knob (Fig. 11 - 2). This locks the blade in place. Close the side panel (Fig. 10 - 2).
3. Insert the top of the blade into the top clamp. Tighten the top blade locking knob (Fig. 11 - 1).
4. Rotate the tension knob (Fig. 10 - 1) away from you to apply tension.

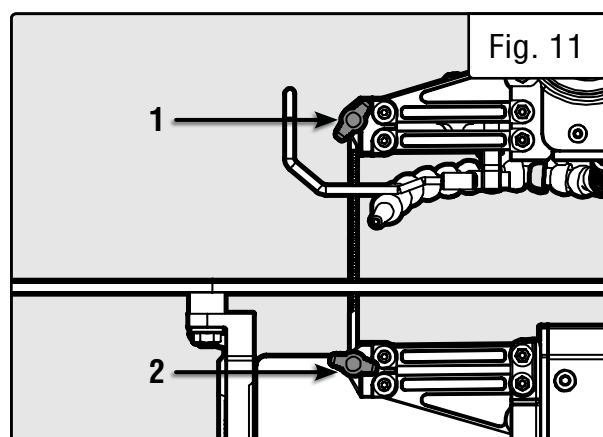

TIP: A properly-tensioned blade will make a high-C sound (C6, 1047 Hz) when plucked with a finger.

BLADE TIPS AND TRICKS

1. You may need to adjust the blade tension. New blades, especially thin ones, will stretch once installed, and may need more tension applied. Use the numbers on the tension knob as a rough guide. 1 represents no tension, 5 represents the most tension. Practice cutting scrap material with various blade thicknesses and types to get familiar with what settings give you the best results.
2. If you are breaking blades frequently, use a lower tension setting.
3. To prolong the life of your blade (and your scroll saw), reduce tension on the blade when you are not using the saw, or remove the blade altogether.

OPERATION

RECOMMENDATIONS FOR CUTTING

A scroll saw is basically a curve-cutting machine. It can also be used for straight cutting and beveling or angle cutting operations. Please read and understand the following directions before attempting to use the saw.

1. When feeding the workpiece into the blade, do not force it against the blade. This could cause blade deflection and poor cutting performance. Let the tool do the work.
2. The blade teeth cut material **ONLY** on the down stroke. Ensure the blade teeth point downwards.
3. Guide the wood into the blade slowly. Again, let the tool do the work.
4. There is a learning curve for each person using this saw. During that period, expect some blades to break as you get the hang of using the saw.
5. Best results are achieved when cutting wood one inch thick or less.
6. When cutting wood thicker than one inch, guide the wood slowly into the blade and take extra care not to bend or twist the blade while cutting, in order to maximize blade life.
7. Teeth on scroll saw blades wear out, and the blades must be replaced frequently for best cutting results. Scroll saw blades generally stay sharp for 1/2 hour to 2 hours of cutting, depending on the type of cut, wood species, etc.
8. To get accurate cuts, be prepared to compensate for the blade's tendency to follow the wood grain.
9. This scroll saw is primarily designed to cut wood or wood products. For cutting precious and non-ferrous metals, the variable control switch must be set at very slow speeds.
10. When choosing a blade, use very fine, narrow blades to scroll cut in thin wood 1/4" thick or less. Use wider blades for thicker materials. This, however, will reduce the ability to cut tight curves.
11. Blades wear down faster when cutting plywood or very abrasive particle board. Angle cutting in hardwoods also wears blades down faster.
12. Before cutting, adjust the blade guard to sit just above the workpiece. This will help you maintain better control over the workpiece.

OPERATION

POWER SWITCH & SPEED CONTROL KNOB

Always wait for the saw to come to a complete stop before re-starting.

1. To turn the saw on, flip the ON/OFF switch (Fig. 12 - 1) to ON. When first starting the saw, it is best to move the speed control knob (Fig. 12 - 2) to the middle speed position.
2. Adjust the blade speed to the desired setting between 550 to 1600 strokes per minute (SPM). Turning the control knob away from you increases speed; turning it towards you reduces speed. Use the numbers on the knob as a reference. 1 represents the minimum speed; 8 represents the maximum.
3. To turn the saw off, flip the ON/OFF switch back to OFF.
4. To lock the switch in the OFF position, remove the yellow safety key from the switch. This will prevent accidental operation. Store the safety key in a safe place.

⚠ WARNING! Remove the safety key whenever the saw is not in use. Place the key in a safe place and out of the reach of children.

⚠ WARNING! To avoid injury from accidental start-ups, always turn the switch OFF and unplug the scroll saw before moving the saw, replacing the blade, or making adjustments.

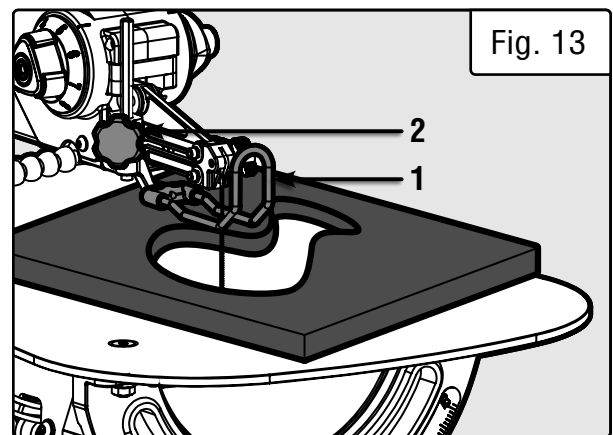
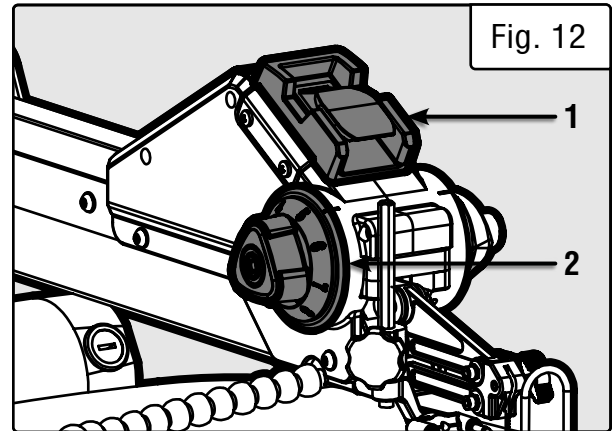

FREEHAND CUTTING

1. Lay out desired design, or secure design to the workpiece.
2. Raise the blade guard foot (Fig. 13 - 1) by loosening the height adjustment knob (Fig. 13 - 2).
3. Position the workpiece against the blade and place the blade guard foot just above the top surface of the workpiece.
4. Secure the blade guard foot (Fig. 13 - 1) by tightening the height adjustment knob (Fig. 13 - 2).
5. Remove the workpiece from the blade prior to turning the scroll saw ON.

⚠ CAUTION! Always make sure the blade is not in contact with the workpiece before turning the saw ON.

6. Slowly feed the workpiece into the blade while holding the workpiece securely against the table.

⚠ CAUTION! Do not force the leading edge of the workpiece into the blade. The blade will deflect, reducing accuracy of cut, and may break

7. When cutting is complete, move trailing edge of the workpiece beyond the blade guard foot. Turn the switch OFF.

OPERATION

ANGLE CUTTING (BEVELING)

1. Layout or secure design to workpiece.
 2. Loosen the height adjustment knob (Fig. 14 - 2), move the blade guard foot (Fig. 14 - 1) to the highest position, and retighten the knob.
 3. Tilt the table to the desired angle by loosening the table bevel lock knob (Fig. 14 - 3). Move the table to the proper angle using the degree scale and the pointer (Fig. 14 - 4).
- TIP:** The table has positive stops at 0, 22.5, 30, and 45 degrees.
4. Tighten the table bevel lock knob (Fig. 14 - 3).
 5. Loosen the blade guard screw, and tilt the blade guard (Fig. 14 - 1) to the same angle as the table. Retighten the blade guard screw. (See also Fig. 6 on p. 11.)
 6. Position the workpiece on the right side of the blade. Lower the blade guard foot against the surface by loosening the height adjustment knob. Retighten.
 7. Follow steps 5 to 7 under Freehand cutting.

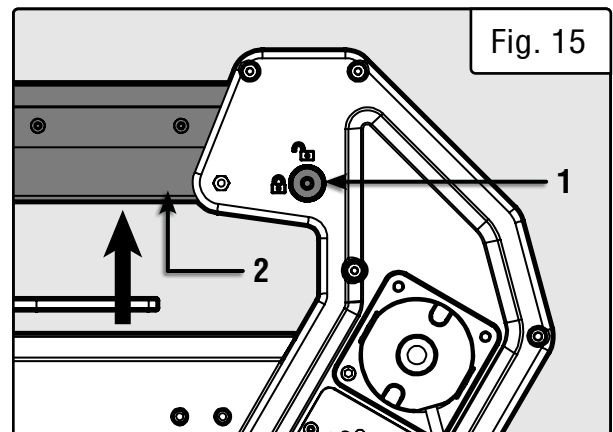
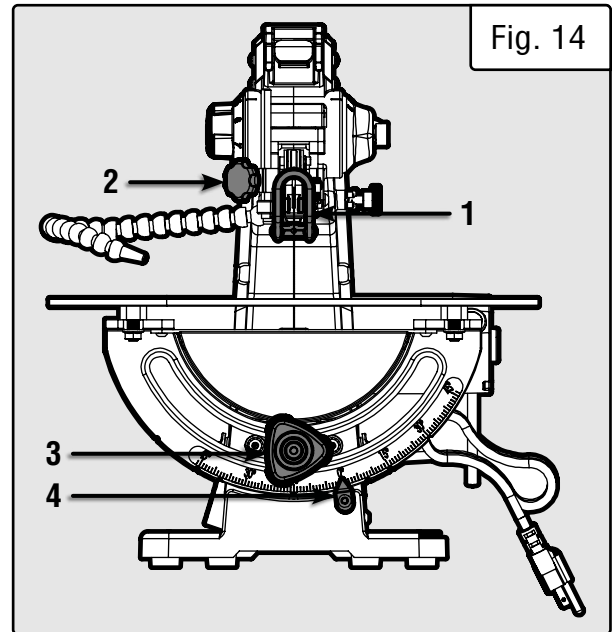

INTERIOR CUTTING & FRETWORK

1. Lay out the design on the workpiece. Drill a 1/4" pilot hole in the workpiece.
2. Remove the blade. See "Blade removal and installation" on p. 13.

NOTE: If you are not changing blades, only remove the blade from upper blade clamp. Leave it installed in the lower blade clamp. If you are changing blades, install new blade in the lower blade clamp. Do not secure it in the upper blade clamp yet.

3. Pull the upper arm release knob (Fig. 15 - 1) outward, and turn it clockwise so the pin rests in the shallow groove.
4. Gently press up on the upper arm (Fig. 15 - 2) of the saw to raise it. Pull the upper arm release knob outward, and turn it so the pin rests in the deep groove. This will lock the upper arm in place. Gently press up on the upper arm to make sure it is locked in place.
5. Place the workpiece on the saw table, threading the blade through the hole in the workpiece.
6. Pull the upper arm release knob outward, and turn it so the pin rests in the shallow groove. Lower the upper arm.
7. Secure the blade in the upper blade clamp, as directed in "Installing the Blade" on p. 13.
8. Follow steps 4 - 7 under "Freehand cutting" on p. 15.
9. When finished making the interior cuts, turn the scroll saw OFF and unplug it. Relieve blade tension and remove the blade from the upper blade clamp. Raise the upper arm, lock it in place, and remove the workpiece. Unlock the upper arm, then lower it.

OPERATION

RIP OR STRAIGHT LINE CUTTING

You will need a straight edge and a clamp (not included).

1. Raise the blade guard foot (Fig. 16 - 1) by loosening the height adjustment knob (Fig. 16 - 2).
2. Measure from the tip of the blade to the desired distance. Position the straight edge parallel to the blade at that distance.
3. Clamp the straight edge to the table.
4. Recheck your measurements using the workpiece to be cut and make sure the straight edge is secure.
5. Position the workpiece against the blade and place the blade guard foot against the top surface of the workpiece.
6. Secure the blade guard foot in place by tightening the height adjustment knob.
7. Remove the workpiece from the blade prior to turning the scroll saw ON.

 **CAUTION!** In order to avoid uncontrollable lifting of the workpiece and reduce blade breakage, do not turn the switch on while the workpiece is against the blade.

8. Position the workpiece against the straight edge prior to touching the leading edge of the workpiece against the blade.
9. Slowly feed the workpiece into the blade, guiding the workpiece against the straight edge and pressing the workpiece down against the table.

 **CAUTION!** Do not force the leading edge of the workpiece into the blade. The blade will deflect, reducing the accuracy of the cut, and may even break.

10. When the cut is complete, move trailing edge of the workpiece beyond the blade guard foot. Turn the switch OFF.

MAINTENANCE

⚠ WARNING! Always turn the switch OFF and unplug the power cord from the outlet before maintaining or lubricating the scroll saw.

To ensure that the wood glides smoothly across the work surface, periodically apply a coat of paste wax (sold separately) to the surface of the worktable. If the power cord is worn out or damaged in any way, replace it immediately. Do not attempt to oil the motor bearings or service the motor's internal parts.

CARBON BRUSH REPLACEMENT

The wear on the carbon brushes depends on how frequently and how heavily the tool is used. To maintain maximum efficiency of the motor, we recommend inspecting the two carbon brushes every 60 hours of operation or when the tool stops working. New carbon brushes are available for purchase from **wenproducts.com** (part number **LL2156-006.1**).

1. Unplug the saw. To access the carbon brushes, remove the carbon brush cover (Fig. 16 - 1) with a flat-head screwdriver (not included).

2. Carefully remove the old carbon brushes. Keep track of which orientation the old carbon brushes were in to prevent unnecessary wear if they will be reinstalled.

3. Measure the length of the brushes. Install the new set of carbon brushes if either carbon brush length is worn down to 3/16" or less. Reinstall the old carbon brushes (in their original orientation) if your brushes are not worn down to 3/16" or less. Both carbon brushes should be replaced at the same time (Fig. 17).

4. Replace the carbon brush cover.

NOTE: New carbon brushes tend to spark for a few minutes during the first use as they wear down.

OVERLOAD PROTECTION

Your scroll saw is equipped with a 5A fuse to protect the motor and electronics. If your scroll saw stops operating, turn off and unplug the saw. To check for a blown fuse:

1. Remove four screws from circuit board cover. Remove cover.

2. Gently slide the circuit board out.

3. Flip up the cover on the fuse compartment (black box on the right side of the board). See Fig. 18.

4. Remove fuse. Replace it with an identical 5A, 250V glass fuse, 5mm x 20mm. Fuse designation is F5AL250V, and is available for purchase at **wenproducts.com** under **part no. LL2156-016.1**.

5. Replace the fuse. Follow steps 1 – 3 in reverse to re-assemble the saw.

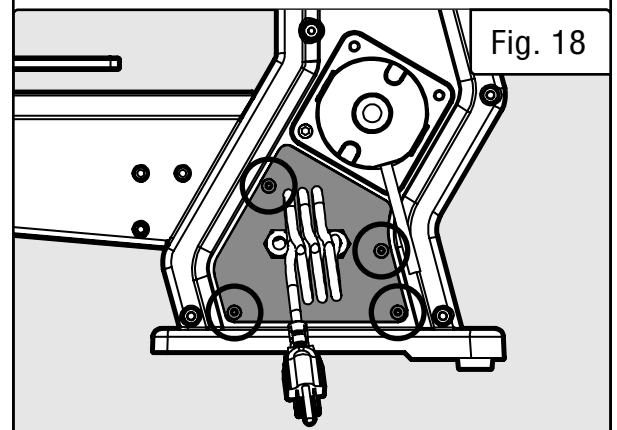
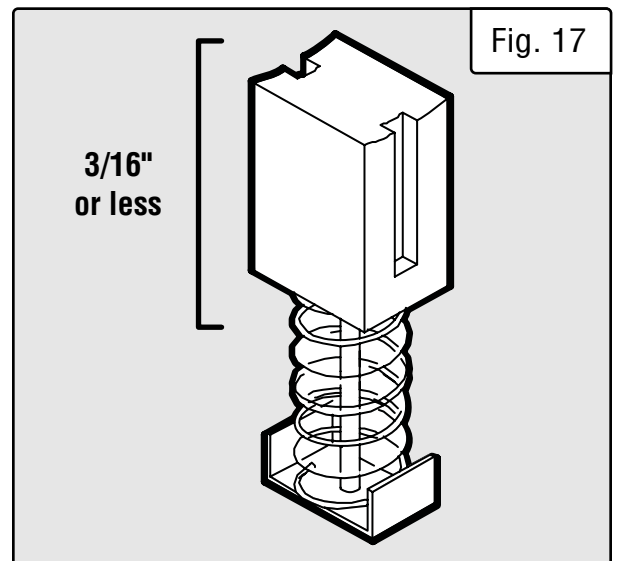
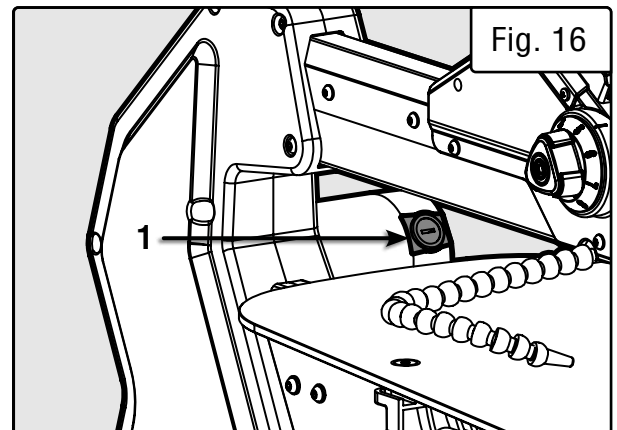

MAINTENANCE

 **WARNING!** Always turn the switch OFF and unplug the power cord from the outlet before maintaining or lubricating the scroll saw.

GENERAL MAINTENANCE

1. Clean your saw after each use. Wipe it down with a soft cloth. Clean any accumulated sawdust out of the base. Use low-pressure compressed air (not to exceed 25 PSI) to blow any sawdust out of the blade holders, blade bevel rails, etc.
2. If desired, apply a light coat of dry lubricant (such as PTFE) to the inside of the blade bevel rails. This will help the table bevel smoothly.
3. The motor bearings, interior bearings, and table bevel rail bearings are all sealed and require no additional lubrication.

TROUBLESHOOTING GUIDE

PROBLEM	POSSIBLE CAUSE	SOLUTION
Motor will not start.	1. Machine not plugged in.	1. Plug unit into power source.
	2. Incorrect size of extension cord.	2. Choose the proper size and length of extension cord.
	3. Worn carbon brushes.	3. Replace carbon brushes; see p. 18.
	4. Blown fuse on main PCB.	4. Replace fuse (F5AL250V). Contact customer service at 1-800-232-1195 for assistance.
	5. Defective power switch, PCB, or motor.	5. Contact customer service at 1-800-232-1195 .
Variable speed does not work.	1. Defective potentiometer (LL2156-055).	1. Contact customer service at 1-800-232-1195
	2. Defective PCB.	2. Contact customer service at 1-800-232-1195
Dust collection ineffective.	1. Side panel open.	1. Make sure side panel is closed for optimum dust collection.
	2. Dust collection system not strong enough.	2. Use a stronger system, or reduce the length of the dust collection hose.
	3. Broken/blocked blower bellows or line.	3. Contact customer service at 1-800-232-1195 .
Excessive vibration.	1. Machine speed set at a harmonic frequency of the saw.	1. Adjust speed up or down to see if issue is resolved.
	2. Machine not secured to work surface.	2. Secure machine to work surface.
	3. Incorrect blade tension.	3. Adjust blade tension (see p. 13).
	4. Hold-down foot not being used.	4. Adjust hold-down foot to slightly clear workpiece surface when cutting.
	5. Loose fastener.	5. Check machine for loose fasteners.
	6. Defective bearing.	6. Contact customer service at 1-800-232-1195 .
Blades keep breaking.	1. Blade tension set too high.	1. Reduce blade tension; see p. 13.
	2. Incorrect blade size.	2. Use a larger (thicker) blade more suitable for the job at hand.
	3. Incorrect blade tooth pitch.	3. Choose a blade with more or fewer teeth per inch (TPI); a minimum of 3 teeth should contact workpiece at all times.
	4. Excessive pressure on blade.	4. Reduce pressure on blade. Let the tool do the work.
Blade drift, or otherwise poor cuts.	1. Excessive pressure on blade.	1. Reduce pressure on blade. Let the tool do the work.
	2. Blade mounted upside-down.	2. Mount blade with teeth pointing down (towards work table).
Tension mechanism does not work.	1. Broken tension linkage or knob.	1. Contact customer service at 1-800-232-1195 .

EXPLODED VIEW & PARTS LIST

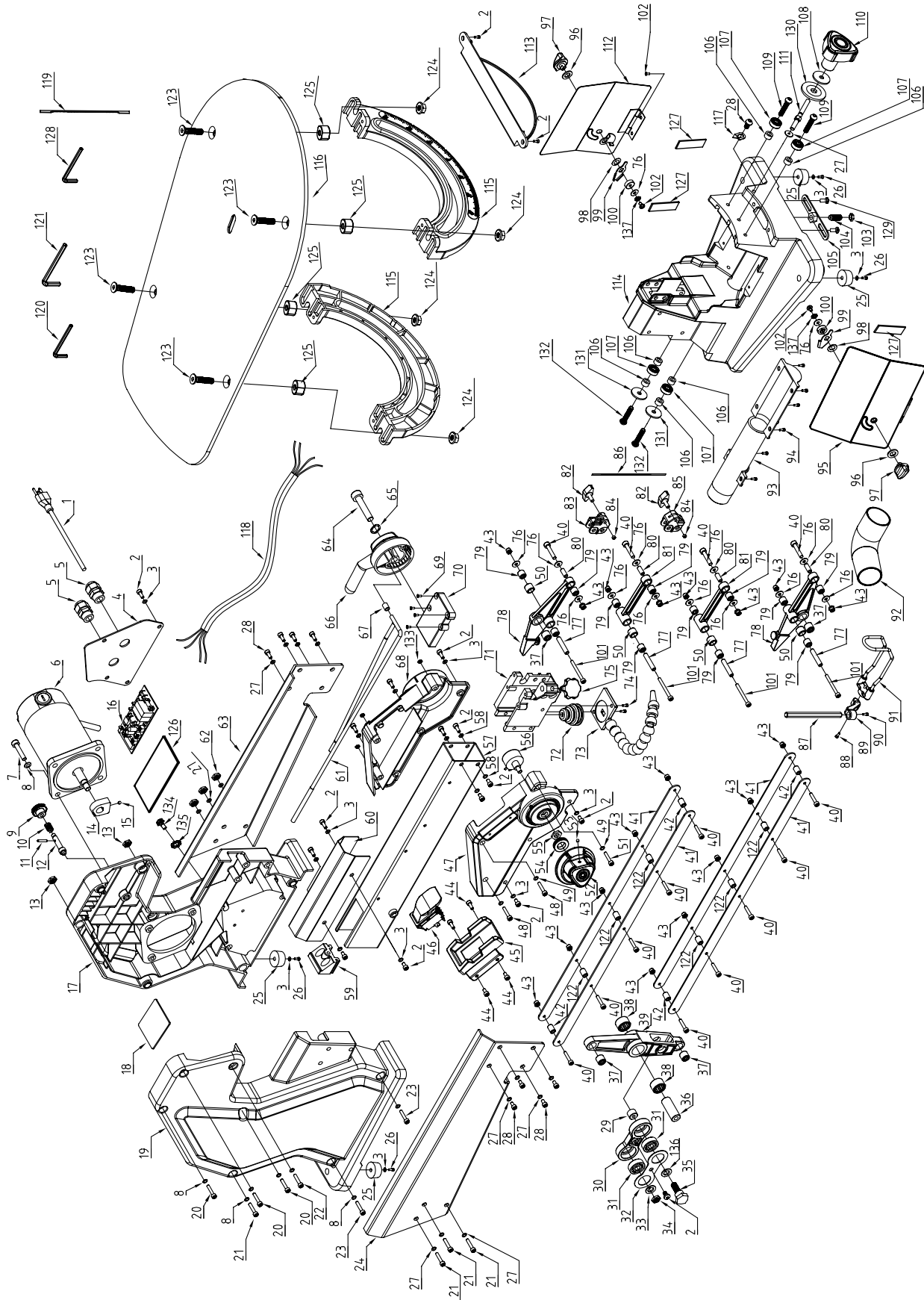

NOTE: Not all parts may be available for purchase. Parts and accessories that wear down over the course of normal use are not covered under the warranty.

EXPLODED VIEW & PARTS LIST

No.	Part No.	Description	Qty.	No.	Part No.	Description	Qty.
1	LL2156-001	Power Cord	1	31	LL2156-031	Bearing, 628-2Z	2
2	LL2156-002	Socket Head Pan Screw, M5x8	21	32	LL2156-032	Connecting Rod Cover Plate	1
3	LL2156-003	Flat Washer, 5mm	18	33	LL2156-033	Lock Washer, 8mm	2
4	LL2156-004	Circuit Board Cover	1	34	LL2156-034	Nut, M8	1
5	LL2156-005	Power Cord Strain Relief	2	35	LL2156-035	Crankshaft Bolt	1
6	LL2156-006	Motor	1	36	LL2156-036	Rocker Arm Shaft	1
N.P.	LL2156-006.1	Carbon Brush (set of 2)	1	37	LL2156-037	Bearing, HK0810	4
7	LL2156-007	Socket Head Cap Screw, M6x20	4	38	LL2156-038	Bearing, HK1412	2
8	LL2156-008	Lock Washer, 6mm	11	39	LL2156-039	Drive Rocker Arm	1
9	LL2156-009	Arm Locking Knob	1	40	LL2156-040	Screw, M4x20	14
10	LL2156-010	Arm Lock Spring	1	41	LL2156-041	Drive Linkage	4
11	LL2156-011	Spring Pin	1	42	LL2156-042	Bearing Sleeve	4
12	LL2156-012	Arm Lock	1	43	LL2156-043	Nut, M4	18
13	LL2156-013	Nut, M6	7	44	LL2156-044	Self-tapping Screw, ST4.2x10	4
14	LL2156-014	Eccentric Wheel	1	45	LL2156-045	Switch Plate	1
15	LL2156-015	Set Screw, M6x10	1	46	LL2156-046	Switch	1
16	LL2156-016	PCB	1	47	LL2156-047B	Left Switch Housing	1
17	LL2156-017	Right Rear Housing	1	48	LL2156-048	Screw, M4x50	2
18	LL2156-018	Tension Plate	1	49	LL2156-049	Flat Washer, 4mm	3
19	LL2156-019	Left Rear Housing	1	50	LL2156-050	Bearing Cushion	4
20	LL2156-020	Socket Head Pan Screw, M6x50	3	51	LL2156-051	Screw, M4x40	1
21	LL2156-021	Socket Head Pan Screw, M6x70	4	52	LL2156-052B	Speed Knob	1
22	LL2156-022	Socket Head Pan Screw, M6x65	1	53	LL2156-053	Screw, M5x8	1
23	LL2156-023	Socket Head Pan Screw, M6x80	2	54	LL2156-054	Rubber Bushing	1
24	LL2156-024	Left Support Plate	1	55	LL2156-055	Potentiometer	1
25	LL2156-025	Rubber Foot	4	56			
26	LL2156-026	Screw, M5x16	4	57	LL2156-057	Arm	1
27	LL2156-027	Flat Washer, 6mm	15	58	LL2156-058	Lock Washer, 5mm	4
28	LL2156-028	Socket Head Pan Screw, M6x12	9	59	LL2156-059	Tension Block	1
29	LL2156-029	Bushing	1	60	LL2156-060	Arm Cover	1
30	LL2156-030	Connecting Rod	1	61	LL2156-061	Tension Rod	1
				62	LL2156-062	Nut, M6	3
				63	LL2156-063	Right Support Plate	1
				64	LL2156-064	Socket Head Cap Screw, M10x40	1
				65	LL2156-065	Wavy Washer, 10mm	1
				66	LL2156-066	Tension Knob	1

EXPLODED VIEW & PARTS LIST

No.	Part No.	Description	Qty.	No.	Part No.	Description	Qty.
67	LL2156-067	Tension Bushing	1	104	LL2156-104	Screw, M8x20	1
68	LL2156-068	Right Switch Housing	1	105	LL2156-105	Positive Stop Positioning Plate	1
69	LL2156-069	Screw M4X20	4	106	LL2156-106	Bearing Spacer	6
70	LL2156-070	Tension Rod Plate	1	107	LL2156-107	Bearing, 606-2Z	4
71	LL2156-071	Upper Housing	1	108	LL2156-108	Bearing Washer	1
72	LL2156-072	Bellows	1	109	LL2156-109	Screw, M6x25	2
73	LL2156-073	Blower	1	110	LL2156-110	Bevel Locking Knob	1
74	LL2156-074	Screw, M4x10	2	111	LL2156-111	Bevel Locking Knob Stud	1
75	LL2156-075	Blade Guard Locking Knob	1	112	LL2156-112	Right Panel Assembly	1
76	LL2156-076	Washer, 4mm	14	113	LL2156-113	Front Guard	1
77	LL2156-077	Bearing Sleeve A	4	114	LL2156-114	Base	1
78	LL2156-078	Front Rocker Arm	2	115	LL2156-115	Table Bevel Rail	2
79	LL2156-079	Bearing, HK0609	12	116	LL2156-116	Table	1
80	LL2156-080	Bearing Sleeve B	4	117	LL2156-117	Pointer	1
81	LL2156-081	Front Pusher Arm	2	118	LL2156-118	Wiring Harness	1
82	LL2156-082	Blade Locking Knob	2	119	LL2156-119	Blade, 18TPI, Pinless	1
83	LL2156-083	Upper Blade Clamp	1	120	LL2156-120	Hex Wrench, 2.5mm	1
84	LL2156-084	Set Screw	2	121	LL2156-121	Hex Wrench, 4mm	1
85	LL2156-085	Lower Blade Clamp	1	122	LL2156-122	Roller	6
86	LL2156-086	Blade, 15TPI, Pinless	1	123	LL2156-123	Flat Hex Head Screw, M8x35	4
87	LL2156-087	Blade Guard Shaft	1	124	LL2156-124	Nut, M8	4
88	LL2156-088	Screw, M5x20	1	125	LL2156-125	Table Damper	4
89	LL2156-089	Blade Guard Seat	1	126	LL2156-126	Foam Pad	1
90	LL2156-090	Screw, M4x12	1	127	LL2156-127	Panel Cushion	4
91	LL2156-091	Blade Guard	1	128	LL2156-128	Hex Wrench, 3mm	1
92	LL2156-092	Dust Port Adapter	1	129	LL2156-129	Screw, M6x12	2
93	LL2156-093	Dust Port	1	130	LL2156-130	Front Rail Plastic Washer	1
94	LL2156-094	Screw, M5x10	6	131	LL2156-131	Rear Rail Plastic Washer	2
95	LL2156-095	Left Panel Assembly	1	132	LL2156-132	Screw, M6x35	2
96	LL2156-096	Flat Washer, 8mm	2	133	LL2156-133	Nut, M4	3
97	LL2156-097	Side Panel Knob	2	134	LL2156-134	Grounding Screw & Washer	1
98	LL2156-098	Wavy Washer, 12.5mm	2	135	LL2156-135	Toothed Lock Washer	1
99	LL2156-099	Door Latch	2				
100	LL2156-100	Guide Sleeve	2				
101	LL2156-101	Screw, M4x40	4				
102	LL2156-102	Screw, M4x12	6				
103	LL2156-103	Nut, M8	1				

NOTE: Not all parts may be available for purchase. Parts and accessories that wear down over the course of normal use are not covered under the warranty.

WARRANTY STATEMENT

WEN Products is committed to building tools that are dependable for years. Our warranties are consistent with this commitment and our dedication to quality.

LIMITED WARRANTY OF WEN PRODUCTS FOR HOME USE

GREAT LAKES TECHNOLOGIES, LLC (“Seller”) warrants to the original purchaser only, that all WEN consumer power tools will be free from defects in material or workmanship during personal use for a period of two (2) years from date of purchase or 500 hours of use; whichever comes first. Ninety days for all WEN products if the tool is used for professional or commercial use. Purchaser has 30 days from the date of purchase to report missing or damaged parts.

SELLER’S SOLE OBLIGATION AND YOUR EXCLUSIVE REMEDY under this Limited Warranty and, to the extent permitted by law, any warranty or condition implied by law, shall be the replacement of parts, without charge, which are defective in material or workmanship and which have not been subjected to misuse, alteration, careless handling, misrepair, abuse, neglect, normal wear and tear, improper maintenance, or other conditions adversely affecting the Product or the component of the Product, whether by accident or intentionally, by persons other than Seller. To make a claim under this Limited Warranty, you must make sure to keep a copy of your proof of purchase that clearly defines the Date of Purchase (month and year) and the Place of Purchase. Place of Purchase must be a direct vendor of Great Lakes Technologies, LLC. Purchasing through third party vendors, including but not limited to garage sales, pawn shops, resale shops, or any other secondhand merchant, voids the warranty included with this product. Contact techsupport@wenproducts.com or 1-800-232-1195 with the following information to make arrangements: your shipping address, phone number, serial number, required part numbers, and proof of purchase. Damaged or defective parts and products may need to be sent to WEN before the replacements can be shipped out.

Upon the confirmation of a WEN representative, your product may qualify for repairs and service work. When returning a product for warranty service, the shipping charges must be prepaid by the purchaser. The product must be shipped in its original container (or an equivalent), properly packed to withstand the hazards of shipment. The product must be fully insured with a copy of the proof of purchase enclosed. There must also be a description of the problem in order to help our repairs department diagnose and fix the issue. Repairs will be made and the product will be returned and shipped back to the purchaser at no charge for addresses within the contiguous United States.

THIS LIMITED WARRANTY DOES NOT APPLY TO ITEMS THAT WEAR OUT FROM REGULAR USAGE OVER TIME, INCLUDING BELTS, BRUSHES, BLADES, BATTERIES, ETC. ANY IMPLIED WARRANTIES SHALL BE LIMITED IN DURATION TO TWO (2) YEARS FROM DATE OF PURCHASE. SOME STATES IN THE U.S. AND SOME CANADIAN PROVINCES DO NOT ALLOW LIMITATIONS ON HOW LONG AN IMPLIED WARRANTY LASTS, SO THE ABOVE LIMITATION MAY NOT APPLY TO YOU.

IN NO EVENT SHALL SELLER BE LIABLE FOR ANY INCIDENTAL OR CONSEQUENTIAL DAMAGES (INCLUDING BUT NOT LIMITED TO LIABILITY FOR LOSS OF PROFITS) ARISING FROM THE SALE OR USE OF THIS PRODUCT. SOME STATES IN THE U.S. AND SOME CANADIAN PROVINCES DO NOT ALLOW THE EXCLUSION OR LIMITATION OF INCIDENTAL OR CONSEQUENTIAL DAMAGES, SO THE ABOVE LIMITATION OR EXCLUSION MAY NOT APPLY TO YOU.

THIS LIMITED WARRANTY GIVES YOU SPECIFIC LEGAL RIGHTS, AND YOU MAY ALSO HAVE OTHER RIGHTS WHICH VARY FROM STATE TO STATE IN THE U.S., PROVINCE TO PROVINCE IN CANADA AND FROM COUNTRY TO COUNTRY.

THIS LIMITED WARRANTY APPLIES ONLY TO ITEMS SOLD WITHIN THE UNITED STATES OF AMERICA, CANADA AND THE COMMONWEALTH OF PUERTO RICO. FOR WARRANTY COVERAGE WITHIN OTHER COUNTRIES, CONTACT THE WEN CUSTOMER SUPPORT LINE. FOR WARRANTY PARTS OR PRODUCTS REPAIRED UNDER WARRANTY SHIPPING TO ADDRESSES OUTSIDE OF THE CONTIGUOUS UNITED STATES, ADDITIONAL SHIPPING CHARGES MAY APPLY.