

No.	Part No.	Description	Qty.	No.	Part No.	Description	Qty.
1	LA4374-001	Back Plate Screw, Phillips-Head, M4x6	2	10	LA4374-010	Jaw 4	1
2	LA4374-002	Back Plate	1	11	LA4275-011	Stop Screw, M4-0.7x8	1
3	LA4374-003	Pinion Screw	2	12	LA4374-012	Screw Chuck, M10-3.0x30	1
4	LA4374-004	Pinion	2	13	LA4374-013	Jaw 3	1
5	LA4374-005	Jaw Carriage 1	1	14	LA4374-014	Jaw Carriage 3	1
6	LA4374-006	Jaw 1	1	15	LA4374-015	Jaw 2	1
7	LA4374-007	Jaw-Mounting Screw, Hex Head, M5x8	8	16	LA4374-016	Jaw Carriage 2	1
8	LA4374-008	Chuck Body Assembly	1	17	LA4275-017	Chuck Key	1
9	LA4374-009	Jaw Carriage 4	1	18	LA4374-018	Hex Wrench, T-Handle, 4mm	1

HAVE PRODUCT QUESTIONS? NEED TECHNICAL SUPPORT? Please feel free to contact us:

1-800-232-1195 (M-F 8AM-5PM CST) | TECHSUPPORT@WENPRODUCTS.COM

This item has a 2-year warranty - for the full warranty statement, please visit wenproducts.com.

Replacement jaws and the most up-to-date instruction manuals can be found on wenproducts.com.



3.75-INCH 4-JAW SELF-CENTERING LATHE CHUCK

Compatible with all WEN Wood Lathes

SPECIFICATIONS

Packing List

Mounting Thread	1"-8
Screw Chuck Thread	M10-3.0x30
Jaw Type	Dovetail
External Grip Range (Fig. 1)	1-1/4" to 2-1/2"
Internal Grip Range (Fig. 2)	1-3/4" to 3-1/8"
Self-Centering	Yes

1) Chuck 1 3) Chuck Key 1
 2) Screw Chuck 1 4) Hex Wrench 1

Your chuck is designed to aid in holding wooden workpieces on your lathe, and is capable of gripping on both the outside and inside of various workpieces.

EXTERNAL GRIP VS INTERNAL GRIP

The external grip is applied on the exterior of the workpiece, while the internal grip is applied on the interior of the workpiece. See Figures 1 & 2.

DOVETAIL JAWS

Your chuck has dovetailed jaws that are suitable for gripping a recess or tenon prepared in your workpiece for clamping. Ensure that the recess or tenon prepared has a flat base so that it can rest flush against the flat surface of the chuck jaws. For the dimensions of your chuck's dovetailed jaws, see Fig. 3.

Visit wenproducts.com and search the phrase "wood lathe" to purchase live centers and other lathe accessories.

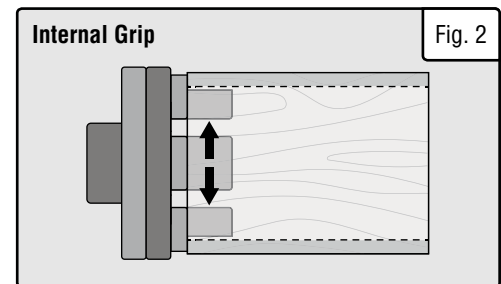
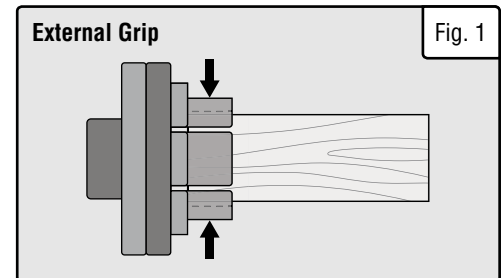

OPERATION

REMOVING THE GREASE

Your chuck comes with a protective layer of grease coating its surfaces. Before you use the chuck, use a dry cloth to remove the protective layer of grease.

USING A LIVE CENTER

If turning long workpieces, use a live center in your tailstock to support the workpiece. Refer to your lathe's manual.

MOUNTING THE CHUCK ON YOUR LATHE

This chuck is compatible with the entire line of WEN wood lathes along with any other wood lathe that has a headstock spindle of 1 inch diameter and 8 threads per inch (1"-8).

1. Thread the chuck onto the headstock spindle by turning the chuck clockwise. Hold the headstock handwheel to keep the spindle stationary. **NOTE:** Depending on your lathe, there may be a different method for keeping the spindle stationary, such as a spindle key or another tool.

2. While holding the spindle stationary, insert the chuck key and use it as a handle to turn the chuck clockwise on the spindle until the chuck is fully secured.

OPENING/CLOSING THE JAWS

1. With the chuck mounted on the lathe, you can open or close the chuck jaws to secure your workpiece. Insert the chuck key into the key hole on the chuck body. See Fig 4.

2. **To open the jaws:** Turn the chuck key counter clockwise.

3. **To close the jaws:** Turn the chuck key clockwise.

4. Place your workpiece flush against the jaw face.

5. Open or close the jaws to internally or externally grip your workpiece (Fig. 1 & 2). The jaws should be fully tightened on your workpiece.

6. To remove the workpiece from the chuck, open or close the jaws to release the grip. Hold your workpiece as you release the grip so it does not fall.

MOUNTING THE SCREW CHUCK

Your LA4374 chuck comes with an M10-3.0x30 screw chuck. The screw chuck is helpful when turning larger workpieces.

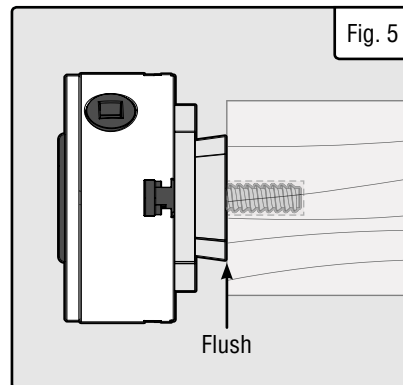
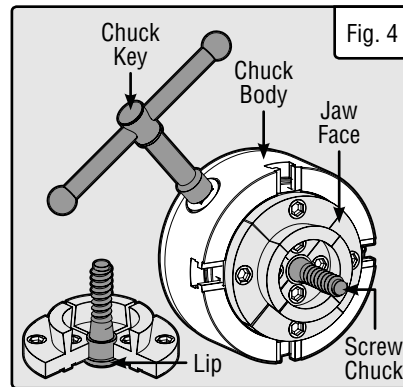
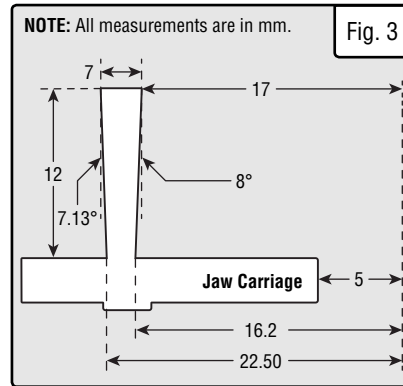

1. Turn OFF and unplug your lathe.

2. Mount the screw chuck in your chuck with an internal grip. The bottom lip of the screw chuck should be under the jaws to help hold it in place. See Fig. 4.

3. The base of the workpiece should be flat and square to its sides. Using a 3/8" drill bit, drill a pilot hole straight down into the center of the workpiece, approximately 31mm (1-7/32") deep.

4. Screw the workpiece onto the screw chuck. The base of the workpiece should be flush against the top of the jaws. See Fig. 5.

MAINTENANCE

WARNING: To avoid accidents, turn OFF the lathe before cleaning, adjusting, or performing any maintenance or lubrication work.

WARNING: When servicing, use only identical WEN replacement parts. Use of other parts may be hazardous or induce product failure.

CLEANING & LUBRICATION

The more care you give your chuck, the longer service life it will give you. For more information on lathe maintenance visit wenproducts.com and search model number LA4374 - you will find links to helpful maintenance guides on the product page.

1. Your chuck will get dirty as it collects chips, dust and other debris from your turning projects. Wipe your chuck down after each use with a soft cloth.

2. If you choose to use compressed air to spray away debris, direct the air outwards, spraying from the center. Limit air pressure to 25 PSI or lower.

3. Apply a dry lubricant (PTFE works well) to the moving parts of the chuck to ensure smooth movement. **NOTE:** Use only dry lubricants - a wet lubricant or grease will cause dust and chips to stick, possibly getting into the interior of the chuck and lead to decreased performance or damage.

4. Occasionally use a small brush, such as a toothbrush, to get hard-to-reach chips off the jaws, jaw carriages, body, etc.

5. Occasionally, open up the jaws and use a wire bottle brush to clean the scroll screw. Run the brush along the screw while turning the chuck key in the keyhole.

6. If desired, you may decide to occasionally tear down your chuck and give it a thorough cleaning. The frequency of this maintenance depends on how often you use the chuck, the species of wood being turned, the size of chips, etc. Visit wenproducts.com and search model number LA4374 - you will find a link with a helpful deep cleaning guide on the product page.

DISPOSAL

When the product reaches the end of its lifetime, please do not dispose of parts with your household waste. This product contains components that should be recycled. Please take this product to your local recycling facility for responsible disposal to minimize its environmental impact.

Please recycle the packaging and components where facilities exist.