

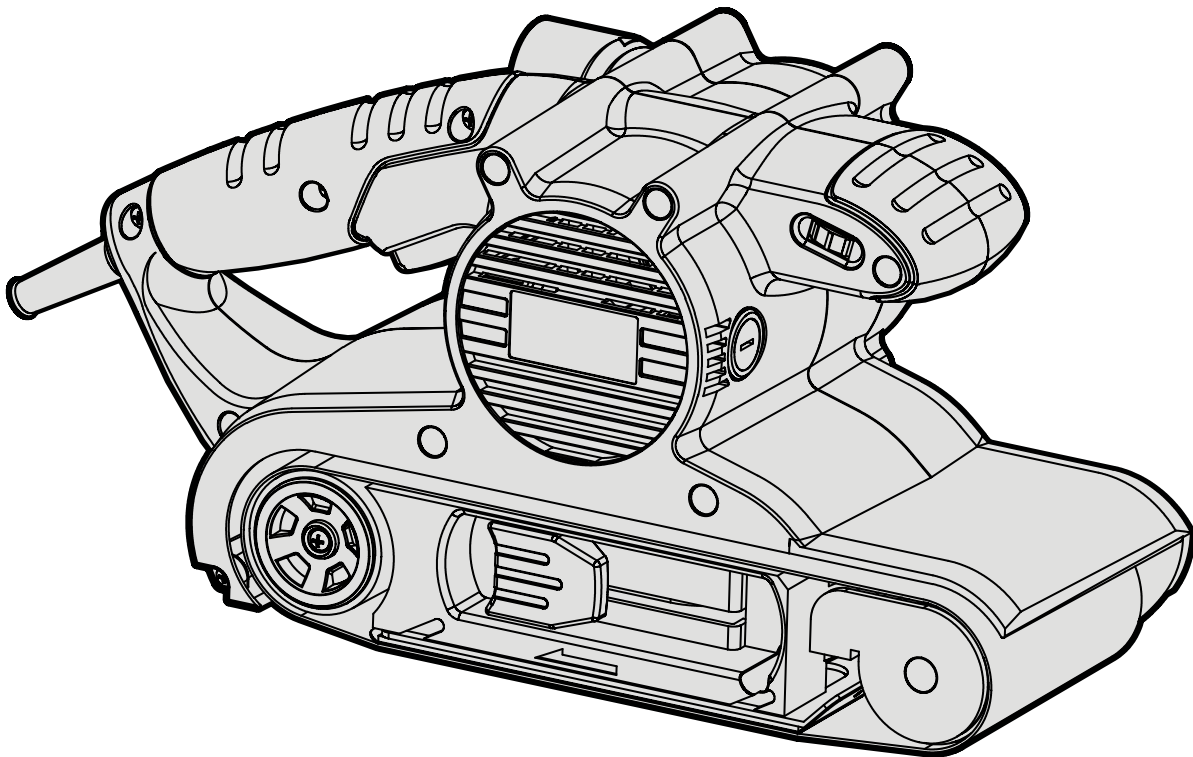

MODEL HB424V

4" x 24" VARIABLE SPEED BELT SANDER

Instruction Manual



NEED HELP? CONTACT US!

Have product questions? Need technical support? Please feel free to contact us:



1-847-429-9263 (M-F 8AM-5PM CST)



TECHSUPPORT@WENPRODUCTS.COM

IMPORTANT: Your new tool has been engineered and manufactured to WEN's highest standards for dependability, ease of operation, and operator safety. When properly cared for, this product will supply you years of rugged, trouble-free performance. Pay close attention to the rules for safe operation, warnings, and cautions. If you use your tool properly and for its intended purpose, you will enjoy years of safe, reliable service.

For replacement parts and the most up-to-date instruction manuals, visit ***WENPRODUCTS.COM***

CONTENTS

WELCOME	3
Introduction	3
Specifications.....	3
SAFETY	4
General Safety Rules	4
Belt Sander Safety Warnings.....	6
Electrical Information.....	8
BEFORE OPERATING	9
Unpacking & Packing List	9
Know Your Belt Sander	10
Assembly & Adjustments.....	11
OPERATION & MAINTENANCE	13
Operation	13
Maintenance.....	14
Troubleshooting Guide.....	15
Exploded View & Parts List.....	16
Warranty Statement	19

To purchase accessories and replacement parts for your tool, visit **WENPRODUCTS.COM**

Replacemet Sanding Belts (Models 424SP60, 424SP80, 424SP120, 424SP240)

INTRODUCTION

Thanks for purchasing the WEN Belt Sander. We know you are excited to put your tool to work, but first, please take a moment to read through the manual. Safe operation of this tool requires that you read and understand this operator's manual and all the labels affixed to the tool. This manual provides information regarding potential safety concerns, as well as helpful assembly and operating instructions for your tool.

 Indicates danger, warning, or caution. The safety symbols and the explanations with them deserve your careful attention and understanding. Always follow the safety precautions to reduce the risk of fire, electric shock or personal injury. However, please note that these instructions and warnings are not substitutes for proper accident prevention measures.

NOTE: The following safety information is not meant to cover all possible conditions and situations that may occur. WEN reserves the right to change this product and specifications at any time without prior notice.

At WEN, we are continuously improving our products. If you find that your tool does not exactly match this manual, please visit wenproducts.com for the most up-to-date manual or contact our customer service at **1-847-429-9263**.

Keep this manual available to all users during the entire life of the tool and review it frequently to maximize safety for both yourself and others.

SPECIFICATIONS

Model Number	HB424V
Motor	120V, 60 Hz, 10A
Belt Speed	656 - 1312 ft / min
Belt Size	4 in. x 24 in.
Sanding Belt	80 Grit
Dust Port Diameter	Outer: 1.40 in. (35.7mm)
	Inner: 1.20 in. (30.7mm)
Product Weight	13.23 Pounds
Product Dimensions	16-1/8 in. x 7-1/8 in. x 7-1/8 in.

GENERAL SAFETY RULES

⚠ WARNING! Read all safety warnings and all instructions. Failure to follow the warnings and instructions may result in electric shock, fire and/or serious injury.

Safety is a combination of common sense, staying alert and knowing how your item works. The term “power tool” in the warnings refers to your mains-operated (corded) power tool or battery-operated (cordless) power tool.

SAVE THESE SAFETY INSTRUCTIONS.

WORK AREA SAFETY

- 1. Keep work area clean and well lit.** Cluttered or dark areas invite accidents.
- 2. Do not operate power tools in explosive atmospheres, such as in the presence of flammable liquids, gases or dust.** Power tools create sparks which may ignite the dust or fumes.
- 3. Keep children and bystanders away while operating a power tool.** Distractions can cause you to lose control.

ELECTRICAL SAFETY

- 1. Power tool plugs must match the outlet. Never modify the plug in any way. Do not use any adapter plugs with earthed (grounded) power tools.** Unmodified plugs and matching outlets will reduce risk of electric shock.
- 2. Avoid body contact with earthed or grounded surfaces such as pipes, radiators, ranges and refrigerators.** There is an increased risk of electric shock if your body is earthed or grounded.
- 3. Do not expose power tools to rain or wet conditions.** Water entering a power tool will increase the risk of electric shock.
- 4. Do not abuse the cord. Never use the cord for carrying, pulling or unplugging the power tool. Keep cord away from heat, oil, sharp edges or moving parts.** Damaged or entangled cords increase the risk of electric shock.
- 5. When operating a power tool outdoors, use an extension cord suitable for outdoor use.** Use of a cord suitable for outdoor use reduces the risk of electric shock.

- 6. If operating a power tool in a damp location is unavoidable, use a ground fault circuit interrupter (GFCI) protected supply.** Use of a GFCI reduces the risk of electric shock.

PERSONAL SAFETY

- 1. Stay alert, watch what you are doing and use common sense when operating a power tool. Do not use a power tool while you are tired or under the influence of drugs, alcohol or medication.** A moment of inattention while operating power tools may result in serious personal injury.
- 2. Use personal protective equipment. Always wear eye protection.** Protective equipment such as a respiratory mask, non-skid safety shoes and hearing protection used for appropriate conditions will reduce the risk of personal injury.
- 3. Prevent unintentional starting. Ensure the switch is in the off-position before connecting to power source and/or battery pack, picking up or carrying the tool.** Carrying power tools with your finger on the switch or energizing power tools that have the switch on invites accidents.
- 4. Remove any adjusting key or wrench before turning the power tool on.** A wrench or a key left attached to a rotating part of the power tool may result in personal injury.
- 5. Do not overreach. Keep proper footing and balance at all times.** This enables better control of the power tool in unexpected situations.
- 6. Dress properly. Do not wear loose clothing or jewelry. Keep your hair and clothing away from moving parts.** Loose clothes, jewelry or long hair can be caught in moving parts.

GENERAL SAFETY RULES

⚠ WARNING! Read all safety warnings and all instructions. Failure to follow the warnings and instructions may result in electric shock, fire and/or serious injury.

Safety is a combination of common sense, staying alert and knowing how your item works. The term “power tool” in the warnings refers to your mains-operated (corded) power tool or battery-operated (cordless) power tool.

SAVE THESE SAFETY INSTRUCTIONS.

7. If devices are provided for the connection of dust extraction and collection facilities, ensure these are connected and properly used. Use of dust collection can reduce dust-related hazards.

POWER TOOL USE AND CARE

1. Do not force the power tool. Use the correct power tool for your application. The correct power tool will do the job better and safer at the rate for which it was designed.

2. Do not use the power tool if the switch does not turn it on and off. Any power tool that cannot be controlled with the switch is dangerous and must be repaired.

3. Disconnect the plug from the power source and/or the battery pack from the power tool before making any adjustments, changing accessories, or storing power tools. Such preventive safety measures reduce the risk of starting the power tool accidentally.

4. Store idle power tools out of the reach of children and do not allow persons unfamiliar with the power tool or these instructions to operate the power tool. Power tools are dangerous in the hands of untrained users.

5. Maintain power tools. Check for misalignment or binding of moving parts, breakage of parts and any other condition that may affect the power tool's operation. If damaged, have the power tool repaired before use. Many accidents are caused by poorly maintained power tools.

6. Keep cutting tools sharp and clean. Properly maintained cutting tools with sharp cutting edges are less likely to bind and are easier to control.

7. Use the power tool, accessories and tool bits, etc. in accordance with these instructions, taking into account the working conditions and the work to be performed. Use of the power tool for operations different from those intended could result in a hazardous situation.

8. Use clamps to secure your workpiece to a stable surface. Holding a workpiece by hand or using your body to support it may lead to loss of control.

9. KEEP GUARDS IN PLACE and in working order.

SERVICE

1. Have your power tool serviced by a qualified repair person using only identical replacement parts. This will ensure that the safety of the power tool is maintained.

CALIFORNIA PROPOSITION 65 WARNING

Some dust created by power sanding, sawing, grinding, drilling, and other construction activities may contain chemicals, including lead, known to the State of California to cause cancer, birth defects, or other reproductive harm. Wash hands after handling. Some examples of these chemicals are:

- Lead from lead-based paints.
- Crystalline silica from bricks, cement, and other masonry products.
- Arsenic and chromium from chemically treated lumber.

Your risk from these exposures varies depending on how often you do this type of work. To reduce your exposure to these chemicals, work in a well-ventilated area with approved safety equipment such as dust masks specially designed to filter out microscopic particles.

BELT SANDER SAFETY WARNINGS

⚠ WARNING! Do not operate the power tool until you have read and understood the following instructions and the warning labels.

⚠ WARNING! EXTREME CAUTION REQUIRED WHEN SANDING PAINT. The dust residue may contain LEAD, which is poisonous. Exposure to even low levels of lead can cause irreversible brain and nervous system damage, to which young and unborn children are particularly vulnerable. Any pre-1960s building may have paint containing lead on wood or metal surfaces that has since been covered with additional layers of paint. Lead-based paints should only be removed by a professional and should not be removed using a sander. If you suspect that paint on surfaces contains lead, please seek professional advice.

⚠ WARNING! USE A FACE MASK AND DUST COLLECTION. Some wood and wood type products, such as MDF (Medium Density Fiberboard), can produce dust that can be hazardous to your health. We recommend the use of a dust extraction system and an approved face mask with replaceable filters when using this machine.

BELT SANDER SAFETY

1. Two-Hand Operation. This machine requires the use of two hands to ensure safe operation.

2. Maintaining a Stable Stance. Ensure proper balance when using the tool. Do not stand on ladders and step ladders during operation. If the machine is to be used on a higher and otherwise unreachable surface, a suitable and stable platform or scaffold tower with hand rails and kick boards should be used.

3. Preparing the Workpiece. Check the workpiece for any protruding nails, screw heads or anything else that could tear or damage the belt.

4. Securing the Workpiece. Never hold the workpiece in your hand or across your legs. Secure small workpieces to prevent the rotating belt from picking them up during forward motion. An unstable or improperly-secured workpiece could cause the belt to bind, resulting in a loss of control and possible injury.

5. Checking the Power Cord. Make sure that the power cord is prevented from coming into contact with the machine or getting caught up on other objects, preventing completion of the sanding pass.

6. Holding the Sander. Keep handles and hands dry, clean and free from oil and grease. Only hold the power tool by the insulated gripping surfaces in case the belt contacts its own cord. Cutting a “live” wire may make exposed metal parts of the tool “live” and could give the operator an electric shock.

7. Sand on Dry Surfaces Only. This machine is to be used for dry sanding only. Do not attempt to use for wet sanding operations, as fatal electric shock may occur.

8. Starting the Sander. Always start the sander before the sanding belt is in contact with the workpiece. Let the sander reach full speed before using the tool. Do not start the machine while it is in contact with the workpiece.

9. Sanding the Workpiece. CAUTION! When the machine contacts the workpiece it will have a tendency to grab and pull forward. Resist the forward motion and keep the belt sander moving at an even pace. Never pull the tool backwards over the workpiece. Sand in the direction of the grain whenever possible. Remove the sanding dust between each grade of sanding sheet. Never leave the machine unattended while it is still running.

10. Setting Down the Sander. Wait for the belt to stop before setting the tool down. An exposed, rotating belt may engage the surface, leading to possible loss of control and serious injury. Always lay the sander on its side to prevent accidents if the machine is inadvertently started.

11. Unplug Your Sander. Ensure that the sander is disconnected from the main supply before servicing, lubricating, making adjustments, changing accessories, or replacing sanding belts. Accidental start-ups may occur if the tool is plugged in during an accessory change. Before plugging the tool back in, check that the trigger is OFF.

BELT SANDER SAFETY WARNINGS

 **WARNING!** Do not operate the power tool until you have read and understood the following instructions and the warning labels.

12. Replacing the Sanding Belt. Replace the sanding belt as soon as it becomes worn or torn. Torn sanding belts can cause deep scratches that are difficult to remove. Ensure that the sanding belt is the correct size for the machine. After changing a sanding belt, rotate the belt to make sure it doesn't hit any part of the tool.

13. Cleaning Your Sander. Clean and maintain your tool periodically. When cleaning a tool, be careful not to disassemble any portion of the tool. Internal wires may be misplaced or pinched and safety guard return springs may be improperly mounted. Certain cleaning agents such as gasoline, carbon tetrachloride, ammonia, etc. may damage plastic parts.

KICKBACK SAFETY

Kickback is a sudden reaction to a pinched or snagged rotating wheel, backing pad, brush or any other accessory. Pinching or snagging causes rapid stalling of the rotating accessory, which in turn causes the uncontrolled power tool to be forced in the direction opposite of the accessory's rotation at the point of binding.

Kickback is the result of power tool misuse and/or incorrect operating procedures or conditions and can be avoided by taking the proper precautions as given below.

1. Maintain a firm grip on the power tool and position your body and arm to allow you to resist kickback forces. Always use the auxiliary handle, if provided, for maximum control over kickback or torque reaction during start-up. The operator can control torque reactions or kickback forces, if proper precautions are taken.

2. Never place your hand near the rotating accessory. The accessory may kick back over your hand.

3. Do not position your body in the area where the power tool will move if kickback occurs. Kickback will propel the tool in the direction opposite to the wheel's movement at the point of snagging.

4. Use special care when working corners, sharp edges, etc. Avoid bouncing and snagging the accessory. Corners, sharp edges or bouncing have a tendency to snag the rotating accessory and cause loss of control or kickback.

VIBRATION SAFETY

This tool vibrates during use. Repeated or long-term exposure to vibration may cause temporary or permanent physical injury, particularly to the hands, arms and shoulders. To reduce the risk of vibration-related injuries:

1. First, be examined by a doctor and then have regular medical check-ups to ensure medical problems are not being caused or worsened from using this tool. People who are pregnant, have impaired blood circulation to the hand, past hand injuries, nervous system disorders, diabetes, or Raynaud's disease should NOT use this tool.

2. If you feel any symptoms related to vibration (such as tingling, numbness, and white or blue fingers), stop working and seek medical advice as soon as possible.

3. Do not smoke during use. Nicotine reduces the blood supply to the hands and fingers, increasing the risk of vibration-related injury.

4. Wear suitable work gloves to reduce the effects of vibration.

5. Hold the tool firmly enough to keep safe control of it, but NOT too tightly. The risk associated with vibration is increased when the gripping force is high. Let the tool do the work.

6. Take vibration-free breaks during each day of work.

ELECTRICAL INFORMATION

DOUBLE-INSULATED TOOL

The tool's electrical system is double-insulated where two systems of insulation are provided. This eliminates the need for the usual three-wire grounded power cord. Double-insulated tools do not need to be grounded, nor should a means for grounding be added to the product. All exposed metal parts are isolated from the internal metal components with protecting insulation.

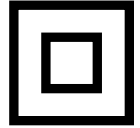

IMPORTANT: Servicing a double-insulated product requires extreme care and knowledge of the system, and should be done only by qualified service personnel using identical replacement parts. Always use original factory replacement parts when servicing.

1. Polarized Plugs. To reduce the risk of electric shock, this equipment has a polarized plug (one blade is wider than the other). This plug will fit in a polarized outlet only one way. If the plug does not fit fully in the outlet, reverse the plug. If it still does not fit, contact a qualified electrician to install a proper outlet. Do not modify the machine plug or the extension cord in any way.

2. Ground fault circuit interrupter protection (GFCI) should be provided on the circuit or outlet used for this power tool to reduce the risk of electric shock.

3. Service and repair. To avoid danger, electrical appliances must only be repaired by a qualified service technician using original replacement parts.

GUIDELINES AND RECOMMENDATIONS FOR EXTENSION CORDS

When using an extension cord, be sure to use one heavy enough to carry the current your product will draw. An undersized cord will cause a drop in line voltage, resulting in loss of power and overheating. The table below shows the correct size to be used according to cord length and ampere rating. When in doubt, use a heavier cord. The smaller the gauge number, the heavier the cord.

AMPERAGE	REQUIRED GAUGE FOR EXTENSION CORDS			
	25 ft.	50 ft.	100 ft.	150 ft.
10A	18 gauge	16 gauge	14 gauge	12 gauge

1. Examine extension cord before use. Make sure your extension cord is properly wired and in good condition. Always replace a damaged extension cord or have it repaired by a qualified person before using it.

2. Do not abuse extension cord. Do not pull on cord to disconnect from receptacle; always disconnect by pulling on plug. Disconnect the extension cord from the receptacle before disconnecting the product from the extension cord. Protect your extension cords from sharp objects, excessive heat and damp/wet areas.

3. Use a separate electrical circuit for your tool. This circuit must not be less than a 12-gauge wire and should be protected with a 15A time-delayed fuse. Before connecting the motor to the power line, make sure the switch is in the OFF position and the electric current is rated the same as the current stamped on the motor nameplate. Running at a lower voltage will damage the motor.

UNPACKING & PACKING LIST

UNPACKING

Carefully remove the belt sander from the packaging and place it on a sturdy, flat surface. Make sure to take out all contents and accessories. Do not discard the packaging until everything is removed. Check the packing list below to make sure you have all of the parts and accessories. If any part is missing or broken, please contact customer service at **1-847-429-9263** (M-F 8-5 CST), or email techsupport@wenproducts.com.

Components

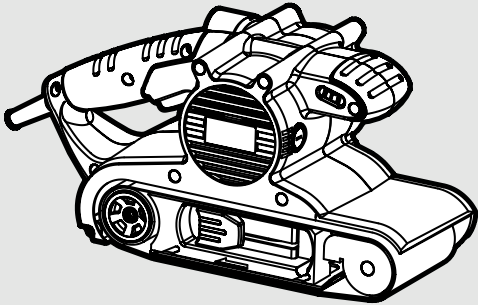

Belt Sander (1)

Accessories

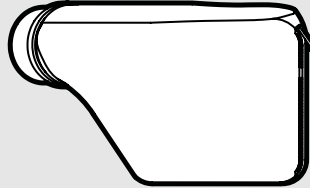

Dust Collection Bag (1)

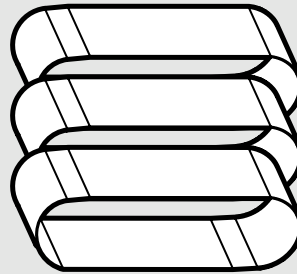

***Sanding Belts (3)**



Rubber Pad (1)

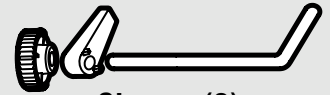
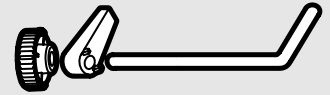

Clamps (2)



Spare Drive Belt (1)

***One sanding belt comes installed on the belt sander.**

KNOW YOUR BELT SANDER

TOOL PURPOSE

Easily shape and finish wood and other materials with your WEN Handheld Belt Sander. Refer to the following diagrams to become familiarized with all the parts and controls of your tool. The components will be referred to later in the manual for assembly and operation instructions.

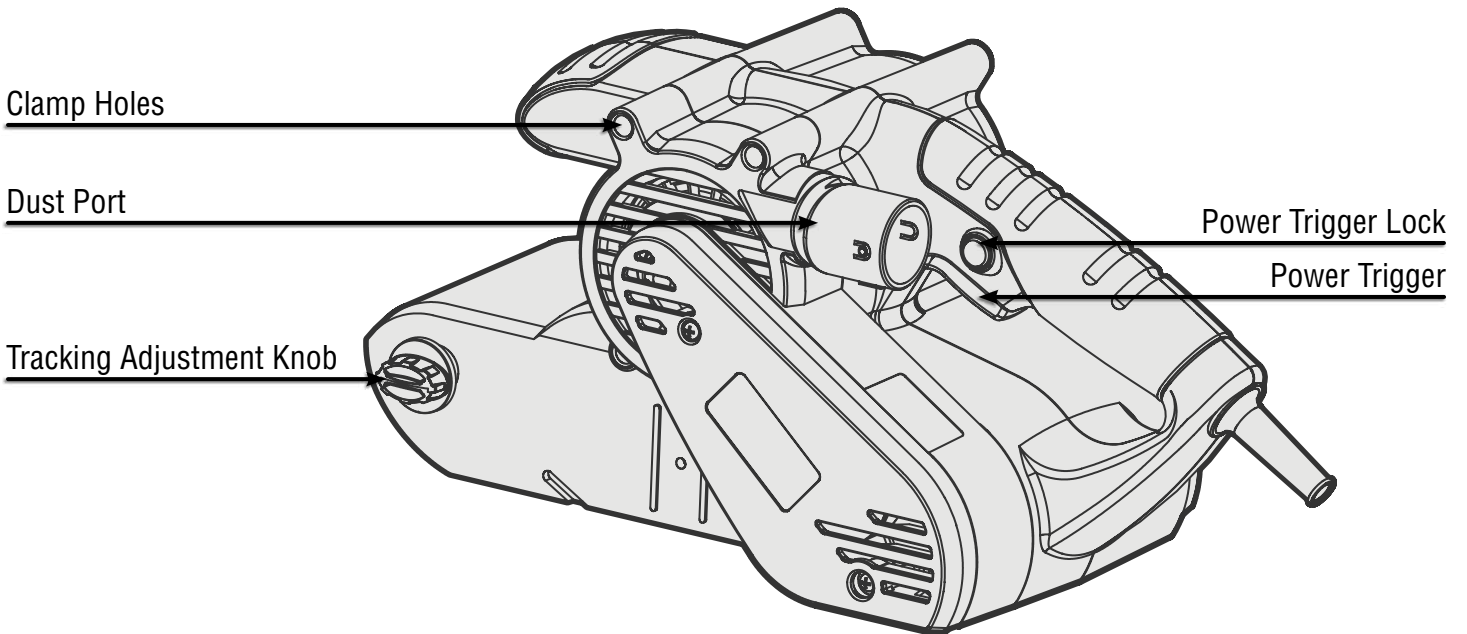
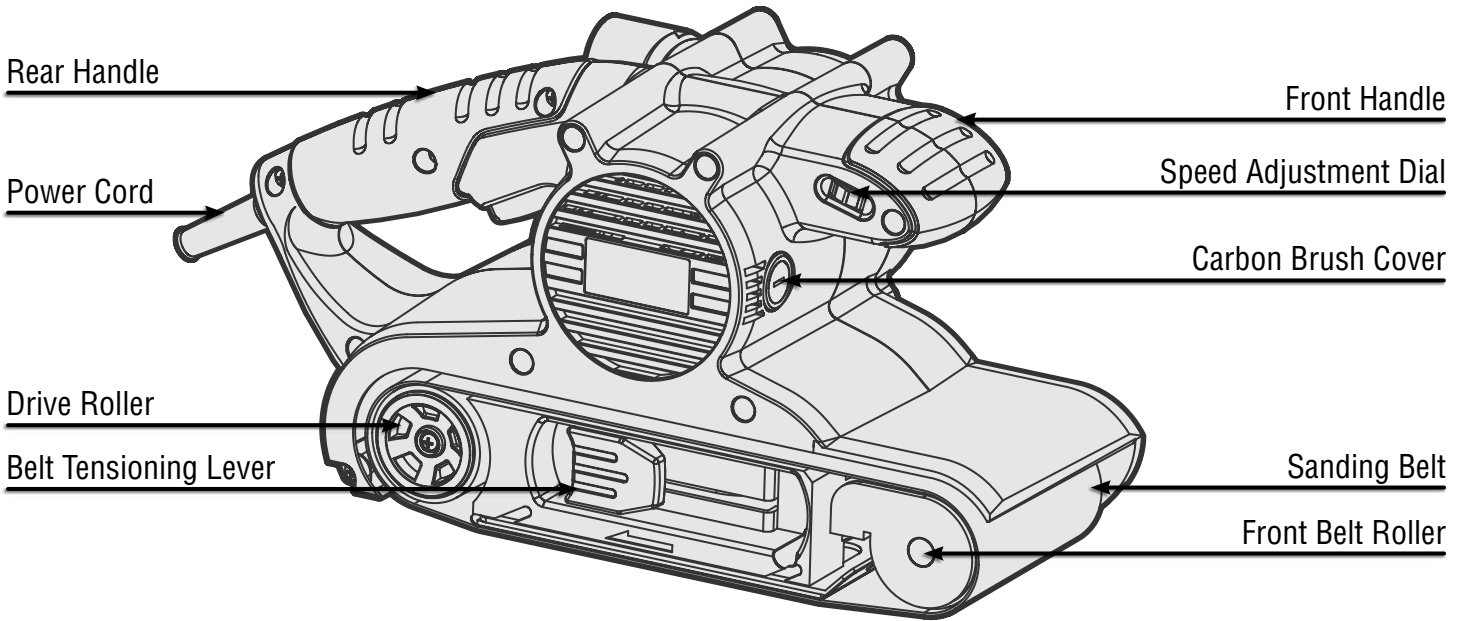

ASSEMBLY & ADJUSTMENTS

CHOOSING SANDING BELTS

Sanding belts come in different grades from rough to smooth. Select the grade required for the particular job. Refer to the table below for the type and applications of different grades. Also refer to the table to select the suitable operating speed setting for your intended use. Your sander comes with three 80-grit sanding belts. Additional sanding belts of various grits can be purchased from wenproducts.com.

NOTE: Do not use the same sanding belt for wood and metal. Avoid creasing by storing belts in hanging positions.

Material	Grit	Rotation Speed
Sanding Softwood	60 - 240	High (5-6)
Sanding Hardwood	60 - 180	High (5-6)
Sanding Chipboard	60 - 150	High (5-6)
Removing Paint/Varnish	60	High (5-6)
Whetting Paints	150 - 320	Low (1-2)
De-Rusting Steel	40 - 120	Med/High (3-4)
Sanding Plastics	120 - 240	Low/Med (2-3)
Nonferrous Metals (ie. Aluminum)	80 - 150	Med/High (3-4)

ATTACHING THE SANDING BELT

1. Unplug the sander, turn it upside down, and set it on a stable surface.

2. Pull out the belt tension lever (Fig. 1 - 1) to retract the front roller (Fig. 1 - 2) and loosen the belt's tension.

3. Slide the sanding belt off.

4. Mount a new sanding belt on the rollers. Make sure that the arrow on the inside of the belt is pointing the same direction as indicated on the tool (Fig. 1 - 3). Check to make sure that the sanding belt does not touch the sides of the casing before turning on the machine.

5. Carefully push the tension lever (Fig. 1 - 1) back to the original position, making sure that it has fully closed.

6. Check that the new belt runs on the center of the rollers. Do this by starting the belt sander to watch how the sanding belt runs. If it shifts along the rollers towards the left or the right, it will require adjustments.

7. To adjust the sanding belt, use the tracking adjustment knob (Fig. 2 - 1), turning it either clockwise or counterclockwise to adjust the angle of the front roller. Run the sander for a short period of time and adjust the tracking until the sanding belt is running in the center of the roller.

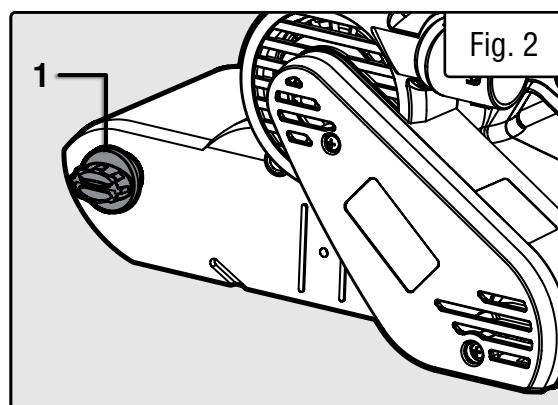
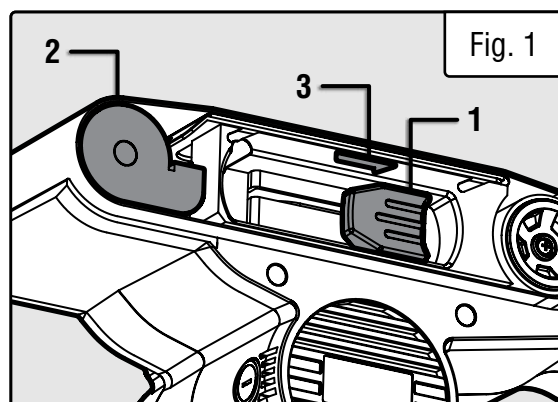

⚠ WARNING! Do not continue to use the sander if the sanding belt is worn or damaged.

⚠ WARNING! Do not use the same sanding belt for wood and metal. Metal particles become embedded in the belt and will damage a wooden surface.

ASSEMBLY & ADJUSTMENTS

DUST COLLECTION

The dust produced by sanding can be hazardous to your health. Always wear a dust mask and operate the tool in a well-ventilated area. This sander comes with a dust collection bag. Before operating the sander, make sure to install the dust bag, or connect the tool to a suitable dust extraction system. The dust port's outer diameter is 1.40 in. (35.7mm); its inner diameter is 1.20 in. (30.7mm).

⚠ CAUTION! When sanding metal, the dust bag or dust extraction system should not be used, as there may be a risk of fire due to flying sparks.

⚠ WARNING! Do not allow the workpiece to overheat. This can cause a fire if the wood dust is mixed with other chemicals, paint residues, or metal residues. Always empty the dust bag and vacuum used before leaving the work station.

INSTALLING DUST COLLECTION BAG

1. 1. Align the notch in the dust collection bag (Fig. 3 - 1) with the tab on the dust extraction port (Fig. 3 - 2) and push the bag onto the port. Make sure that the dust bag is secure and the zipper is closed before beginning operation.

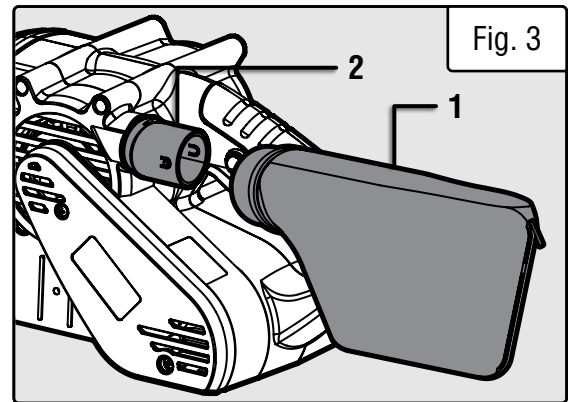

REMOVING & EMPTYING THE DUST COLLECTION BAG

1. Turn off and unplug sander. Pull the dust bag off of the dust extraction port. Open the zipper over a garbage can and empty the bag.

NOTE: Check and empty dust bag often, before it gets full.

⚠ CAUTION! Wear respiratory protection when emptying the bag.

DUST EXTRACTION SYSTEM

1. With the dust collection bag removed, attach the dust hose of your dust extraction system to the dust extraction port (Fig. 3 - 3). You may install a dust port adapter (not included), or reducer to adjust the size of the dust port to fit your dust hose.

2. Attach a dust extraction hose onto the dust port adapter, or reducer (if used).

3. Connect the other end of the dust extraction hose to the dust extraction system of your choice.

NOTE: when using a dust extraction system, you may notice some static discharge.

OPERATION

⚠ CAUTION! Never cover the air vents. They must always be open for proper motor cooling. Make sure that the work piece is free of nails and other foreign objects that could tear the abrasive belt.

OPERATING THE BELT SANDER

1. Hold machine firmly with both hands and assume a balanced position.
2. Pull the trigger switch (Fig. 4 - 1) and allow the motor to reach full speed. For continuous operation, press in the power lock-on button located on the side of the handle (Fig. 4 - 2).
3. Hold the machine parallel to the work piece. Gently bring belt into contact with the surface.

⚠ CAUTION! The sander may initially lunge forward. Resist the forward motion and keep the belt sander moving at an even pace.

Never exert excessive pressure on the tool. The weight of the tool applies adequate pressure. Excessive pressure prevents proper sanding, leaving an uneven finish and excess wear to both the tool and the abrasive belt.

4. Adjust the belt's speed using the speed adjustment dial (Fig. 5 - 1) on the side of the front handle. Consult the chart on p. 11 for recommended belt speeds for various jobs.

4. Once finished, lift the belt sander off the work piece before turning off the switch. Wait until the belt has stopped rotating before setting down the tool on its side.

⚠ CAUTION! If the sander makes an unfamiliar sound or vibrates excessively switch it off immediately and disconnect from the power supply.

USING THE CLAMPS

The included clamps allow you to fix the sander to a work surface with the sanding belt facing upward.

1. Flip the belt sander upside down so that the sanding belt faces upwards. Make sure that the surface you are clamping to is flat and stable. Place the sander on top of the included rubber pad (Fig. 6 - 1). The rubber pad will help prevent damage to your work surface.
2. Insert the two clamps into the clamp holes as shown in Fig. 6. Make sure that the clamps rest securely against the edge of the work surface.
3. Tighten the knobs (Fig. 6 - 2). Make sure that the belt sander is secured to the work surface before beginning operation.

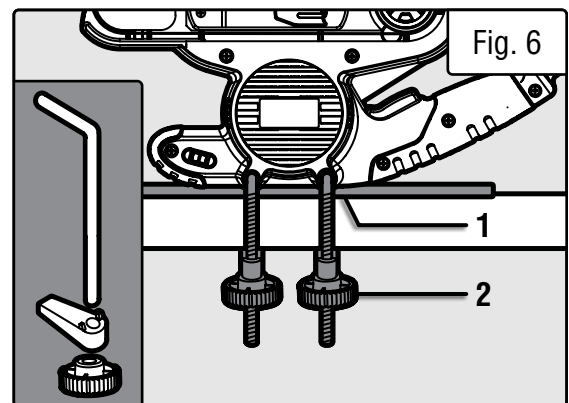
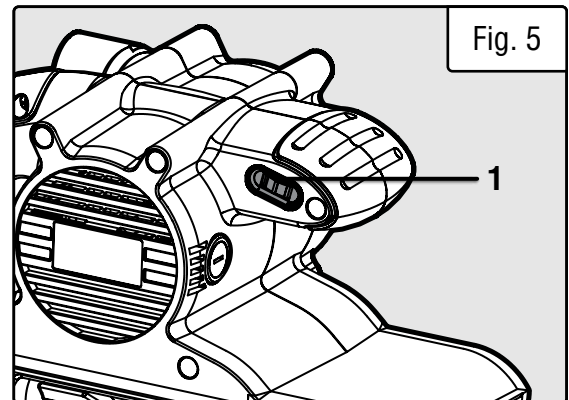
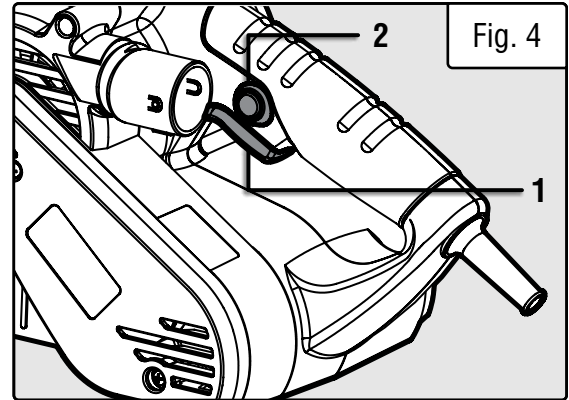

MAINTENANCE

⚠ WARNING! To avoid accidents, make sure the power switch is in the OFF position and unplug the tool from the electrical outlet before cleaning or performing any maintenance. Servicing of the tool must be performed by a qualified technician.

REPLACING THE CARBON BRUSHES

To maintain maximum efficiency of the motor, we recommend changing the carbon brushes every 50 hours of operation. Replacement carbon brushes (**part no. HB424V-093**) are available at **wenproducts.com**. Only genuine WEN replacement brushes designed specifically for your tool should be used.

To inspect or replace the carbon brushes:

1. Remove the two carbon brush covers (Fig. 7 - 1) using a flat-head screw driver (no included).
2. When removing the carbon brushes, take note of their orientation. The new carbon brushes will need to be installed in the same orientation.

NOTE: Both carbon brushes should be replaced at the same time.

3. Install the new carbon brushes and replace the carbon brush covers.
4. Once the new carbon brushes have been installed, run the belt sander to make sure that the brushes have been installed correctly.

NOTE: It is normal for new carbon brushes to spark a bit as they wear in.

REPLACING THE DRIVE BELT

Your sander comes with a replacement drive belt. Further replacement drive belts (**part no. HB424V-064**) are available at **wenproducts.com**.

1. Using a Phillips-head screwdriver (not included), remove the two screws (Fig. 8 - 1) on the drive belt cover.
2. Remove the worn belt by first sliding it off the bottom drive pulley and lifting it away from the sander.
3. Clean all dust and debris from the sander.
4. Place the new drive belt over the top drive pulley and onto the bottom drive pulley. Rotate the belt until it is centered on both pulleys. It should fit between the two grooves on the pulleys.
5. Replace the drive belt cover.
6. Run the belt sander on low speed to ensure that the drive belt has been installed correctly.

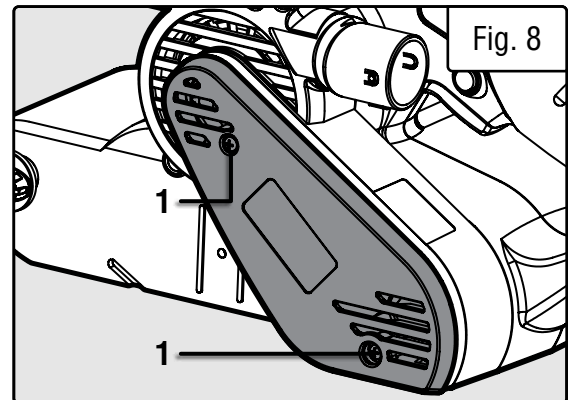
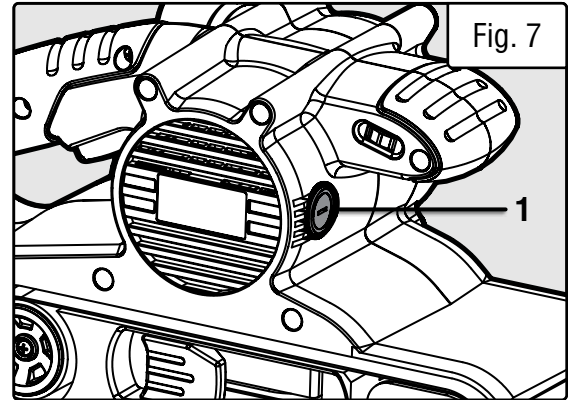

SERVICE

Preventive maintenance performed by unauthorized personnel may result in misplacing of internal wires and components, possibly causing a serious hazard. Call WEN customer service line at **1-847-429-9263** for product support.

CLEANING

Ventilation openings and switch levers must be kept clean and free of foreign matter. The tool may be cleaned most effectively with compressed dry air. Do not attempt to clean these components by inserting pointed objects through openings. Certain cleaning agents and solvents damage plastic parts; this includes but is not limited to gasoline, carbon tetrachloride, chlorinated cleaning solvents, ammonia and household detergents that contain ammonia.

TROUBLESHOOTING GUIDE

⚠ WARNING! Stop using the tool immediately if any of the following problems occur. Repairs and replacements should only be performed by an authorized technician. For any questions, please contact our customer service at **1-847-429-9263**, M-F 8-5 CST or email us at **techsupport@wenproducts.com**.

PROBLEM	CAUSE	SOLUTION
Motor does not start	1. Power cord damaged or not properly plugged in.	1. Check the power cord, extension cord, power plug and the power outlet. Make sure the outlet is functional. Do not use the tool if any cord is damaged.
	2. Defective power switch.	2. Stop using the tool and contact customer service at 1-847-429-9263 , M-F 8-5 CST for assistance.
	3. Insufficient power from power outlet.	3. Make sure the outlet is functional and is the right capacity for the tool.
	4. Carbon brushes (HB424V-093) are worn.	4. Inspect and replace carbon brushes as needed (see p. 11). Replacement brushes (HB424V-093) can be ordered from wenproducts.com .
	5. Defective motor.	5. Stop using the tool and contact customer service at 1-847-429-9263 , M-F 8-5 CST for assistance.
Excessive noise or vibration	1. Internal damage or wear.	1. Contact customer service at 1-847-429-9263 , M-F 8-5 CST for assistance.
Overheating	1. Tool forced to work too fast.	1. Do not force the tool and let it work at its own pace.
	2. The extension cord is too long or too thin	2. See p. 7 for selecting the proper size of extension cord for your tool.
	3. Blocked motor housing vents	3. Blow dust out of the motor housing vents while wearing safety goggles and dust mask.
Ineffective Performance	1. Drive bits worn or damaged.	1. Replace bits as needed.
	2. Carbon brushes (HB424V-093) are worn.	2. Inspect and replace carbon brushes as needed (see p. 11). Replacement brushes (HB424V-093) can be ordered from wenproducts.com .
	3. Demotivated sander.	3. Give your sander some encouragement.

NOTE: Parts that wear down over the course of normal use (like accessories, carbon brushes, etc.) are not covered by the two-year warranty. Repairs and replacements should only be performed by an authorized technician.

EXPLODED VIEW & PARTS LIST

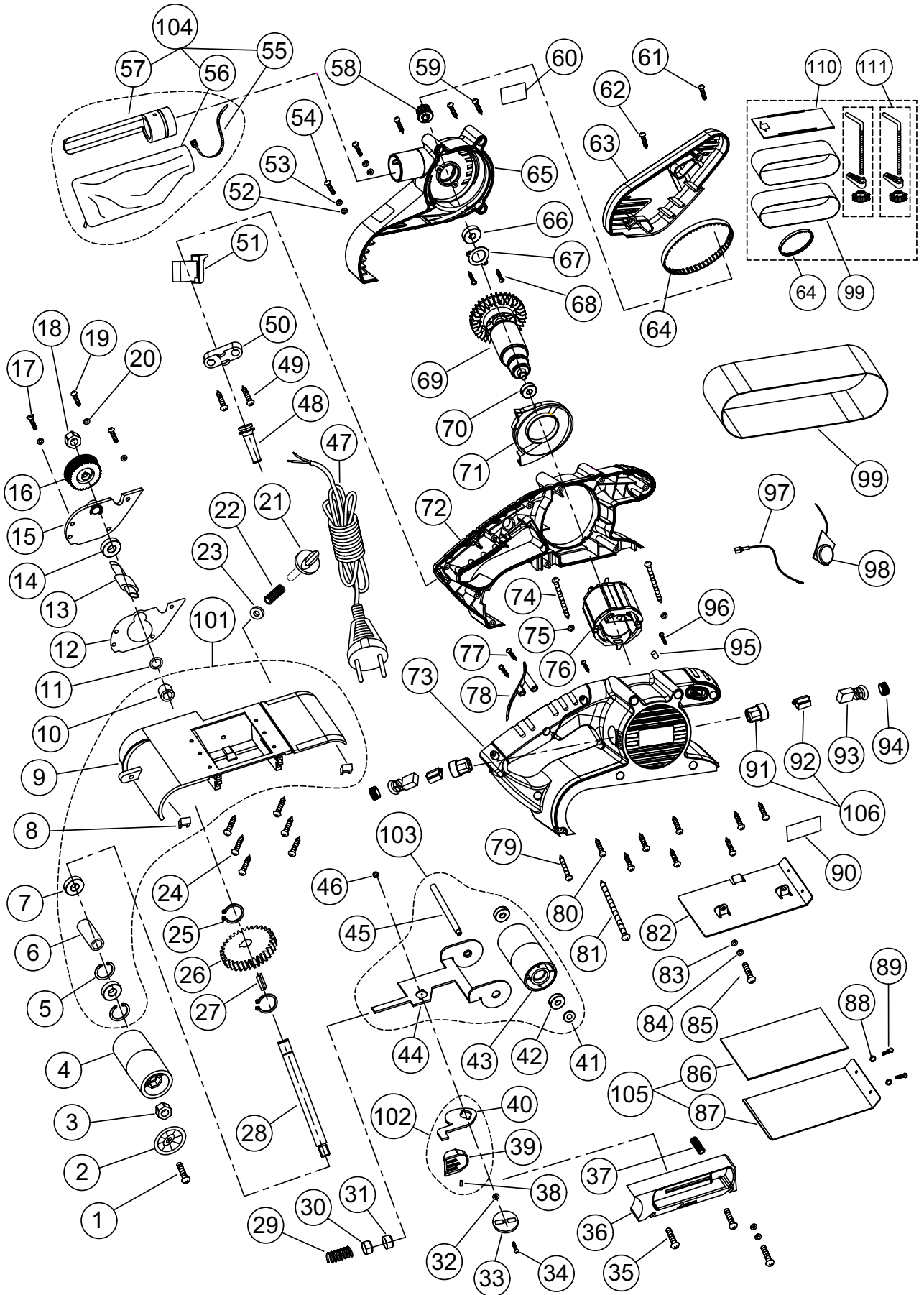

EXPLODED VIEW & PARTS LIST

No.	Part No.	Description	Qty.	No.	Part No.	Description	Qty.
1	HB424V-001	Phillips-Head Screw, M4x10	1	31	HB424V-031	Spring Sleeve	1
2	HB424V-002	Roller Cover	1	32	HB424V-032	Washer, 3mm	1
3	HB424V-003	Nut, M10x1.0, Left-Handed	1	33	HB424V-033	Block	1
4	HB424V-004	Drive Roller	1	34	HB424V-034	Phillips-Head Screw, M3x10	1
101	HB424V-101ASM	Sanding Belt Housing Assembly	1	35	HB424V-017	Phillips-Head Screw, M5x12	2
5	HB424V-005	Sealing Ring, 28mm	3	36	HB424V-036	Tension Lever Housing	1
6	HB424V-006	Roller Sleeve	1	37	HB424V-021	Spring	1
7	HB424V-007	Bearing, 6001-2Z	2	102	HB424V-102ASM	Tension Lever Assembly	1
8	HB424V-008	Ceramic Plate	2	38	HB424V-038	Pin	1
9	HB424V-009	Belt Housing Plate	1	39	HB424V-039	Tension Lever Bracket	1
10	HB424V-010	Needle Bearing, HK081210	1	40	HB424V-040	Tension Lever	1
11	HB424V-011	Washer, 8mm	1	103	HB424V-103ASM	Driven Roller Assembly	1
12	HB424V-012	Cover	1	41	HB424V-041	Driven Roller	1
102	HB424V-102ASM	Pulley Assembly	1	42	HB424V-042	Bearing, 608-2Z	2
13	HB424V-013	Pulley Shaft	1	43	HB424V-043	Washer, 8mm	2
14	HB424V-014	Bearing, 628-RS	1	44	HB424V-044	Fork	1
15	HB424V-015	Pulley Cover	1	45	HB424V-045	Roller Shaft	1
16	HB424V-016	Driven Pulley	1	46	HB424V-046	Hex Nut, M3	1
17	HB424V-017	Phillips-Head Screw, M5x12	1	47	HB424V-047	Power Cord	1
18	HB424V-098	Hex Nut, M8	1	48	HB424V-048	Strain Relief	1
19	HB424V-017	Phillips-Head Screw, M5x12	2	49	HB424V-022	Self-tapping Screw, ST4.0x16	2
20	HB424V-020	Washer, 5mm	3	50	HB424V-050	Cord Clamp	1
21	HB424V-021	Tracking Knob	1	51	HB424V-051	Switch	1
22	HB424V-022	Spring	1	52	HB424V-052	Washer, 5mm	2
23	HB424V-023	Rubber Washer	1	53	HB424V-053	Lock Washer, 5mm	2
24	HB424V-024	Self-Tapping Screw, ST4.0x16	6	54	HB424V-054	Phillips-head Screw, M5x16	2
25	HB424V-025	External Circlip, 12mm	2	104	HB424V-104ASM	Dust Bag Assembly	1
26	HB424V-026	Big Gear	1	55	HB424V-055	Bag Cord	1
27	HB424V-027	Key, 4x4x12	1	56	HB424V-056	Dust Bag	1
28	HB424V-028	Gear Shaft	1	57	HB424V-057	Dust Bag Bracket	1
29	HB424V-029	Roller Fork Spring	1	58	HB424V-022	Drive Pulley	1
30	HB424V-030	Plastic Spring Sleeve	1				

EXPLODED VIEW & PARTS LIST

No.	Part No.	Description	Qty.	No.	Part No.	Description	Qty.
59	HB424V-059	Self-Tapping Screw, ST4.0x16	3	81	HB424V-081	Self-Tapping Screw, ST4.0x76	1
60	HB424V-022	Label	1	82	HB424V-082	Baseplate, Top	1
61	HB424V-017	Self-Tapping Screw, ST4.0x16	1	83	HB424V-052	Washer, 5mm	2
62	HB424V-062	Phillips-Head Screw, M5x12	1	84	HB424V-053	Lock Washer, 5mm	2
63	HB424V-063	Belt Cover	1	85	HB424V-017	Phillips-Head Screw, M5x12	2
64	HB424V-064	Drive Belt, 124XL	1	105	HB424V-106ASM	Base Assembly	1
65	HB424V-065	Left Housing	1	86	HB424V-086	Cork Board	1
66	HB424V-066	Bearing, 629-2RS	1	87	HB424V-087	Baseplate, Bottom	1
67	HB424V-067	Bearing Cover	1	88	HB424V-088	Washer, 4mm	2
68	HB424V-068	Self-Tapping Screw, ST3.0x10	2	89	HB424V-001	"Cross Recess Head Screw"	2
69	HB424V-041	Rotor	1	90	HB424V-090	Logo Label	1
70	HB424V-070	Bearing, 608-2Z	1	107	HB424V-107ASM	Brush Holder Assembly	1
71	HB424V-071	Fan Housing	1	91	HB424V-091	Brush Holder	2
72	HB424V-072	Middle and Right Housing Assembly	1	92	HB424V-092	Brush Support	
73				93	HB424V-093	Carbon Brushes, Set of 2	2
74	HB424V-074	Self-Tapping Screw, ST4.0x65	2	94	HB424V-094	Brush Cap	2
86 to 75	HB424V-086	Washer, 4mm	2	95	HB424V-095	Rubber Bit	1
76	HB424V-076	Stator	1	96	HB424V-096	Self-Tapping Screw, ST3.0x10F	2
77	HB424V-067	Self-Tapping Screw, ST3.0x10	2	97	HB424V-097	Connector Wire	2
78	HB424V-078	Dust Cover	1	98	HB424V-098	PCB	1
79	HB424V-079	Self-Tapping Screw, ST4.0x30	1	99	HB424V-099	Sanding Belt, 80-grit, 4x24	1
80	HB424V-022	Self-Tapping Screw, ST4.0x16	8	110	HB424V-PAD	Rubber Pad	1
				111	HB424V-CLAMP	Clamp Assembly	2

NOTE: Not all parts may be available for purchase. Parts and accessories that wear down over the course of normal use are not covered under the warranty.

WARRANTY STATEMENT

WEN Products is committed to building tools that are dependable for years. Our warranties are consistent with this commitment and our dedication to quality.

LIMITED WARRANTY OF WEN PRODUCTS FOR HOME USE

GREAT LAKES TECHNOLOGIES, LLC (“Seller”) warrants to the original purchaser only, that all WEN consumer power tools will be free from defects in material or workmanship during personal use for a period of two (2) years from date of purchase or 500 hours of use; whichever comes first. Ninety days for all WEN products if the tool is used for professional or commercial use. Purchaser has 30 days from the date of purchase to report missing or damaged parts.

SELLER’S SOLE OBLIGATION AND YOUR EXCLUSIVE REMEDY under this Limited Warranty and, to the extent permitted by law, any warranty or condition implied by law, shall be the replacement of parts, without charge, which are defective in material or workmanship and which have not been subjected to misuse, alteration, careless handling, misrepair, abuse, neglect, normal wear and tear, improper maintenance, or other conditions adversely affecting the Product or the component of the Product, whether by accident or intentionally, by persons other than Seller. To make a claim under this Limited Warranty, you must make sure to keep a copy of your proof of purchase that clearly defines the Date of Purchase (month and year) and the Place of Purchase. Place of Purchase must be a direct vendor of Great Lakes Technologies, LLC. Purchasing through third party vendors, including but not limited to garage sales, pawn shops, resale shops, or any other secondhand merchant, voids the warranty included with this product. Contact techsupport@wenproducts.com or 1-847-429-9263 with the following information to make arrangements: your shipping address, phone number, serial number, required part numbers, and proof of purchase. Damaged or defective parts and products may need to be sent to WEN before the replacements can be shipped out.

Upon the confirmation of a WEN representative, your product may qualify for repairs and service work. When returning a product for warranty service, the shipping charges must be prepaid by the purchaser. The product must be shipped in its original container (or an equivalent), properly packed to withstand the hazards of shipment. The product must be fully insured with a copy of the proof of purchase enclosed. There must also be a description of the problem in order to help our repairs department diagnose and fix the issue. Repairs will be made and the product will be returned and shipped back to the purchaser at no charge for addresses within the contiguous United States.

THIS LIMITED WARRANTY DOES NOT APPLY TO ITEMS THAT WEAR OUT FROM REGULAR USAGE OVER TIME, INCLUDING BELTS, BRUSHES, BLADES, BATTERIES, ETC. ANY IMPLIED WARRANTIES SHALL BE LIMITED IN DURATION TO TWO (2) YEARS FROM DATE OF PURCHASE. SOME STATES IN THE U.S. AND SOME CANADIAN PROVINCES DO NOT ALLOW LIMITATIONS ON HOW LONG AN IMPLIED WARRANTY LASTS, SO THE ABOVE LIMITATION MAY NOT APPLY TO YOU.

IN NO EVENT SHALL SELLER BE LIABLE FOR ANY INCIDENTAL OR CONSEQUENTIAL DAMAGES (INCLUDING BUT NOT LIMITED TO LIABILITY FOR LOSS OF PROFITS) ARISING FROM THE SALE OR USE OF THIS PRODUCT. SOME STATES IN THE U.S. AND SOME CANADIAN PROVINCES DO NOT ALLOW THE EXCLUSION OR LIMITATION OF INCIDENTAL OR CONSEQUENTIAL DAMAGES, SO THE ABOVE LIMITATION OR EXCLUSION MAY NOT APPLY TO YOU.

THIS LIMITED WARRANTY GIVES YOU SPECIFIC LEGAL RIGHTS, AND YOU MAY ALSO HAVE OTHER RIGHTS WHICH VARY FROM STATE TO STATE IN THE U.S., PROVINCE TO PROVINCE IN CANADA AND FROM COUNTRY TO COUNTRY.

THIS LIMITED WARRANTY APPLIES ONLY TO ITEMS SOLD WITHIN THE UNITED STATES OF AMERICA, CANADA AND THE COMMONWEALTH OF PUERTO RICO. FOR WARRANTY COVERAGE WITHIN OTHER COUNTRIES, CONTACT THE WEN CUSTOMER SUPPORT LINE. FOR WARRANTY PARTS OR PRODUCTS REPAIRED UNDER WARRANTY SHIPPING TO ADDRESSES OUTSIDE OF THE CONTIGUOUS UNITED STATES, ADDITIONAL SHIPPING CHARGES MAY APPLY.

**THANKS FOR
REMEMBERING**  [®]