

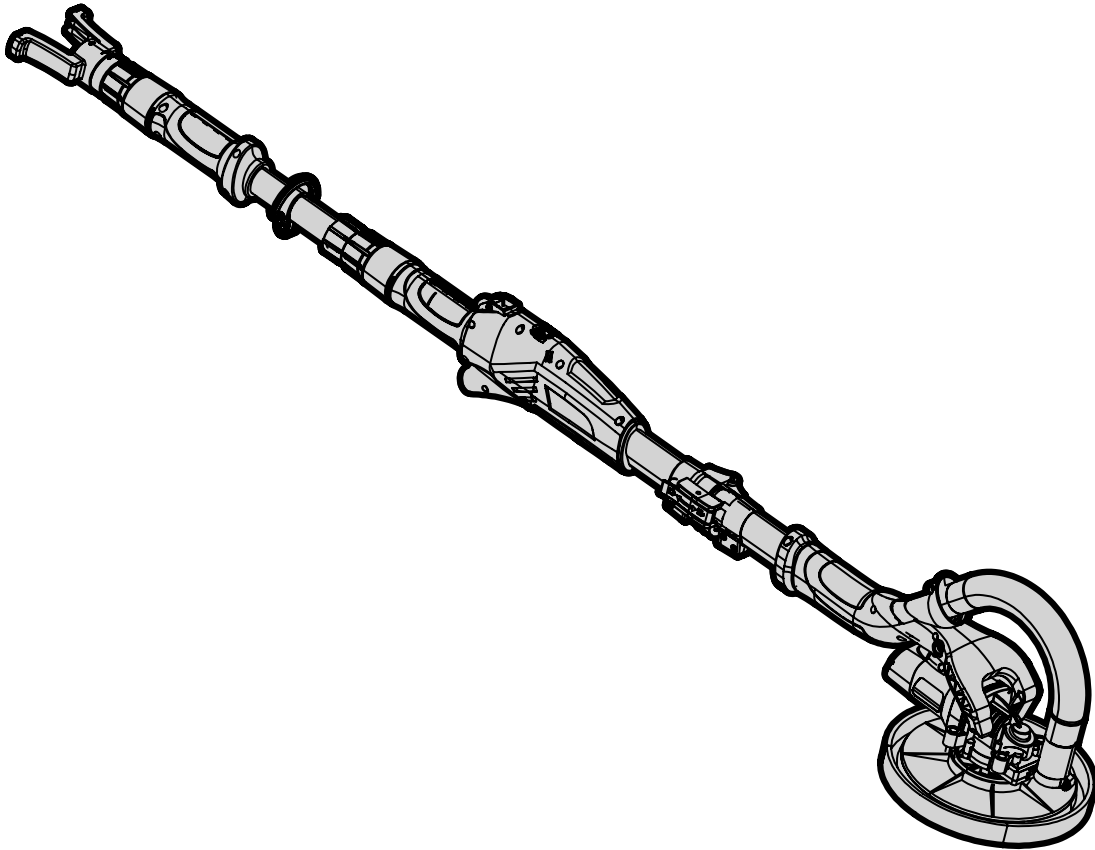

**MODEL DW5062**

# ***VARIABLE SPEED DRYWALL SANDER***

**Instruction Manual**



## ***NEED HELP? CONTACT US!***

Have product questions? Need technical support? Please feel free to contact us:



**1-847-429-9263 (M-F 8AM-5PM CST)**



**TECHSUPPORT@WENPRODUCTS.COM**

**IMPORTANT:** Your new tool has been engineered and manufactured to WEN's highest standards for dependability, ease of operation, and operator safety. When properly cared for, this product will supply you years of rugged, trouble-free performance. Pay close attention to the rules for safe operation, warnings, and cautions. If you use your tool properly and for its intended purpose, you will enjoy years of safe, reliable service.

For replacement parts and the most up-to-date instruction manuals, visit ***WENPRODUCTS.COM***

# CONTENTS

<b>WELCOME</b>	<b>3</b>
Introduction .....	3
Specifications.....	3
<b>SAFETY</b>	<b>4</b>
General Safety Rules .....	4
Drywall Sander Safety Warnings.....	6
Electrical Information .....	8
<b>BEFORE OPERATING</b>	<b>9</b>
Know Your Drywall Sander .....	9
Assembly & Adjustments.....	10
<b>OPERATION &amp; MAINTENANCE</b>	<b>11</b>
Operation .....	11
Maintenance.....	11
Troubleshooting Guide.....	12
Exploded View & Parts List.....	13
Warranty Statement .....	16

To purchase replacement sandpaper for your tool, visit ***WENPRODUCTS.COM***

**60-Grit Drywall Sandpaper, 10 Pack** (Model DW60SP)  
**80-Grit Drywall Sandpaper, 10 Pack** (Model DW80SP)  
**120-Grit Drywall Sandpaper, 10 Pack** (Model DW120SP)  
**150-Grit Drywall Sandpaper, 10 Pack** (Model DW150SP)  
**180-Grit Drywall Sandpaper, 10 Pack** (Model DW180SP)  
**240-Grit Drywall Sandpaper, 10 Pack** (Model DW240SP)  
**15-Foot Dust Hose** (Part Number 6369-103)

## INTRODUCTION

Thanks for purchasing the WEN Drywall Sander. We know you are excited to put your tool to work, but first, please take a moment to read through the manual. Safe operation of this tool requires that you read and understand this operator's manual and all the labels affixed to the tool. This manual provides information regarding potential safety concerns, as well as helpful assembly and operating instructions for your tool.

 Indicates danger, warning, or caution. The safety symbols and the explanations with them deserve your careful attention and understanding. Always follow the safety precautions to reduce the risk of fire, electric shock or personal injury. However, please note that these instructions and warnings are not substitutes for proper accident prevention measures.

**NOTE:** The following safety information is not meant to cover all possible conditions and situations that may occur. WEN reserves the right to change this product and specifications at any time without prior notice.

At WEN, we are continuously improving our products. If you find that your tool does not exactly match this manual, please visit [wenproducts.com](http://wenproducts.com) for the most up-to-date manual or contact our customer service at **1-847-429-9263**.

**Keep this manual available to all users during the entire life of the tool and review it frequently to maximize safety for both yourself and others.**

## SPECIFICATIONS

Model Number	DW5062
Motor	120V, 60 Hz, 5A
Speed	600 to 1500 RPM (No Load)
Hook & Loop Base Diameter	8.5 Inches
Shortened Length	43.3 Inches
Length with Extension	51.2 to 63 Inches
Sanding Pad Diameter	9 Inches
Sandpaper Grits	60, 80, 120, 150, 180, and 240
Dust Port Size	1.25 Inches
Product Weight	11.5 Pounds

# GENERAL SAFETY RULES

 **WARNING!** Read all safety warnings and all instructions. Failure to follow the warnings and instructions may result in electric shock, fire and/or serious injury.

Safety is a combination of common sense, staying alert and knowing how your item works. The term “power tool” in the warnings refers to your mains-operated (corded) power tool or battery-operated (cordless) power tool.

## SAVE THESE SAFETY INSTRUCTIONS.

### WORK AREA SAFETY

- 1. Keep work area clean and well lit.** Cluttered or dark areas invite accidents.
- 2. Do not operate power tools in explosive atmospheres, such as in the presence of flammable liquids, gases or dust.** Power tools create sparks which may ignite the dust or fumes.
- 3. Keep children and bystanders away while operating a power tool.** Distractions can cause you to lose control.

### ELECTRICAL SAFETY

- 1. Power tool plugs must match the outlet. Never modify the plug in any way. Do not use any adapter plugs with earthed (grounded) power tools.** Unmodified plugs and matching outlets will reduce risk of electric shock.
- 2. Avoid body contact with earthed or grounded surfaces such as pipes, radiators, ranges and refrigerators.** There is an increased risk of electric shock if your body is earthed or grounded.
- 3. Do not expose power tools to rain or wet conditions.** Water entering a power tool will increase the risk of electric shock.
- 4. Do not abuse the cord. Never use the cord for carrying, pulling or unplugging the power tool. Keep cord away from heat, oil, sharp edges or moving parts.** Damaged or entangled cords increase the risk of electric shock.
- 5. When operating a power tool outdoors, use an extension cord suitable for outdoor use.** Use of a cord suitable for outdoor use reduces the risk of electric shock.

**6. If operating a power tool in a damp location is unavoidable, use a ground fault circuit interrupter (GFCI) protected supply.** Use of a GFCI reduces the risk of electric shock.

### PERSONAL SAFETY

- 1. Stay alert, watch what you are doing and use common sense when operating a power tool. Do not use a power tool while you are tired or under the influence of drugs, alcohol or medication.** A moment of inattention while operating power tools may result in serious personal injury.
- 2. Use personal protective equipment. Always wear eye protection.** Protective equipment such as a respiratory mask, non-skid safety shoes and hearing protection used for appropriate conditions will reduce the risk of personal injury.
- 3. Prevent unintentional starting. Ensure the switch is in the off-position before connecting to power source and/or battery pack, picking up or carrying the tool.** Carrying power tools with your finger on the switch or energizing power tools that have the switch on invites accidents.
- 4. Remove any adjusting key or wrench before turning the power tool on.** A wrench or a key left attached to a rotating part of the power tool may result in personal injury.
- 5. Do not overreach. Keep proper footing and balance at all times.** This enables better control of the power tool in unexpected situations.
- 6. Dress properly. Do not wear loose clothing or jewelry. Keep your hair and clothing away from moving parts.** Loose clothes, jewelry or long hair can be caught in moving parts.

# GENERAL SAFETY RULES

 **WARNING!** Read all safety warnings and all instructions. Failure to follow the warnings and instructions may result in electric shock, fire and/or serious injury.

Safety is a combination of common sense, staying alert and knowing how your item works. The term “power tool” in the warnings refers to your mains-operated (corded) power tool or battery-operated (cordless) power tool.

## SAVE THESE SAFETY INSTRUCTIONS.

**7. If devices are provided for the connection of dust extraction and collection facilities, ensure these are connected and properly used.** Use of dust collection can reduce dust-related hazards.

### POWER TOOL USE AND CARE

**1. Do not force the power tool. Use the correct power tool for your application.** The correct power tool will do the job better and safer at the rate for which it was designed.

**2. Do not use the power tool if the switch does not turn it on and off.** Any power tool that cannot be controlled with the switch is dangerous and must be repaired.

**3. Disconnect the plug from the power source and/or the battery pack from the power tool before making any adjustments, changing accessories, or storing power tools.** Such preventive safety measures reduce the risk of starting the power tool accidentally.

**4. Store idle power tools out of the reach of children and do not allow persons unfamiliar with the power tool or these instructions to operate the power tool.** Power tools are dangerous in the hands of untrained users.

**5. Maintain power tools. Check for misalignment or binding of moving parts, breakage of parts and any other condition that may affect the power tool's operation. If damaged, have the power tool repaired before use.** Many accidents are caused by poorly maintained power tools.

**6. Keep cutting tools sharp and clean.** Properly maintained cutting tools with sharp cutting edges are less likely to bind and are easier to control.

**7. Use the power tool, accessories and tool bits, etc. in accordance with these instructions, taking into account the working conditions and the work to be performed.** Use of the power tool for operations different from those intended could result in a hazardous situation.

**8. Use clamps to secure your workpiece to a stable surface.** Holding a workpiece by hand or using your body to support it may lead to loss of control.

**9. KEEP GUARDS IN PLACE** and in working order.

### SERVICE

**1. Have your power tool serviced by a qualified repair person using only identical replacement parts.** This will ensure that the safety of the power tool is maintained.

### CALIFORNIA PROPOSITION 65 WARNING

Some dust created by power sanding, sawing, grinding, drilling, and other construction activities may contain chemicals, including lead, known to the State of California to cause cancer, birth defects, or other reproductive harm. Wash hands after handling. Some examples of these chemicals are:

- Lead from lead-based paints.
- Crystalline silica from bricks, cement, and other masonry products.
- Arsenic and chromium from chemically treated lumber.

Your risk from these exposures varies depending on how often you do this type of work. To reduce your exposure to these chemicals, work in a well-ventilated area with approved safety equipment such as dust masks specially designed to filter out microscopic particles.

## **DRYWALL SANDER SAFETY WARNINGS**

 **WARNING!** Do not let comfort or familiarity with the product replace strict adherence to product safety rules. Failure to follow the safety instructions may result in serious personal injury.

### **DRYWALL SANDER SAFETY**

1. This power tool is intended for sanding drywall for home use only. Using this tool for professional purposes will reduce the tool's lifespan and cause parts to wear down sooner. Do not force the machine to do other jobs, such as grinding, cutting off, grooming, etc. Operations for which the tool was not designed, including modification of the machine, may cause machine damage, personal injuries, and invalidate the warranty.

2. Keep bystanders and all other living creatures, including children and pets, away from the work area.

3. Do not operate the tool in the presence of flammable liquids or gases. Do not operate the tool in wet or damp conditions; doing so significantly increases the risk of electrical shock.

4. The following personal protective equipment must be used to reduce the risk of personal injuries:

- ANSI Z87.1-approved impact-resistant safety goggles with side shields. Safety goggles should be worn during operation, assembly or maintenance of the tool.
- Ear protection such as plugs or muffs. Failure to use adequate ear protectors when the noise level is high can result in hearing loss and other problems, such as tinnitus (ringing, whistling or buzzing in the ear).
- Face mask or dust mask to fight the debris produced by operation. The dust generated during may carry health risks (e.g. cancer, birth defects, asthma and/or dermatitis). Work in a well-ventilated environment and wear a dust masks specially designed to filter out microscopic particles.
- Heavy-duty work gloves to protect your hands.
- Safety non-slip work boots.
- Safety helmet if any work is being carried out above your head.

5. The rated speed of the accessories must be greater than or equal to the tool's maximum speed of 1500 RPM. Do not use accessories rated at speeds below the machine's maximum RPM.

6. Do not use sanding discs larger than the recommended size of 9 inches in diameter. Incorrectly sized accessories will not get along with your sander.

7. Always hold your tool firmly with both hands to maintain control and to avoid kickback.

8. Position the power cord clear of the rotating accessory to avoid accidentally damaging the cord.

9. Do not run the power tool while carrying it at your side. Accidental contact with the rotating accessory could snag your clothing, pulling the accessory into your body.

10. Never lay the power tool down until the accessory has come to a complete stop. The rotating accessory may grab the surface and pull the sander out of your control.

11. Always turn the tool OFF and disconnect the power before making adjustments or performing maintenance.

12. Maintain the tool properly. Keep your machine's ventilation slots and dust port clean. Keep the tool and accessories clean and in good working order. Have your tool serviced by a qualified repair person using only identical replacement parts.

# **DRYWALL SANDER SAFETY WARNINGS**

 **WARNING!** Do not let comfort or familiarity with the product replace strict adherence to product safety rules. Failure to follow the safety instructions may result in serious personal injury.

## **KICKBACK AND RELATED WARNINGS**

Kickback is a sudden reaction to a pinched or snagged rotating wheel, backing pad, brush or any other accessory. Pinching or snagging causes rapid stalling of the rotating accessory which in turn causes the uncontrolled power tool to be forced in the direction opposite of the accessory's rotation at the point of the binding.

Kickback is the result of power tool misuse and/or incorrect operating procedures or conditions and can be avoided by taking proper precautions as given below.

1. Maintain a firm grip on the power tool and position your body and arm to allow you to resist kickback forces. Always use auxiliary handle, if provided, for maximum control over kickback or torque reaction during start-up. The operator can control torque reactions or kickback forces, if proper precautions are taken.
2. Never place your hand near the rotating accessory. The accessory may kickback over your hand.
3. Do not position your body in the area where power tool will move if kickback occurs. Kickback will propel the tool in the direction opposite to the wheel's movement at the point of snagging.
4. Use special care when working corners, sharp edges etc. Avoid bouncing and snagging the accessory. Corners, sharp edges or bouncing have a tendency to snag the rotating accessory and cause loss of control or kickback.

## **VIBRATION SAFETY**

This tool vibrates during use. Repeated or long-term exposure to vibration may cause temporary or permanent physical injury, particularly to the hands, arms and shoulders. To reduce the risk of vibration-related injuries:

1. First be examined by a doctor and then have regular medical check-ups to ensure medical problems are not being caused or worsened from using this tool. People who are pregnant, have impaired blood circulation to the hand, past hand injuries, nervous system disorders, diabetes, or Raynaud's disease should NOT use this tool.
2. If you feel any symptoms related to vibration (such as tingling, numbness, and white or blue fingers), stop working and seek medical advice as soon as possible.
3. Wear suitable work gloves to reduce the effects of vibration.
4. Hold the tool firmly enough to keep safe control of it, but NOT too tightly. The risk associated with vibration is increased when the gripping force is high. Let the tool do the work.
5. Take vibration-free breaks during each day of work.

**These safety instructions can't possibly warn of every scenario that may arise with this tool, so always make sure to stay alert and use common sense during operation.**

# ELECTRICAL INFORMATION

## DOUBLE-INSULATED TOOLS

The tool's electrical system is double-insulated where two systems of insulation are provided. This eliminates the need for the usual three-wire grounded power cord. Double-insulated tools do not need to be grounded, nor should a means for grounding be added to the product. All exposed metal parts are isolated from the internal metal motor components with protecting insulation.

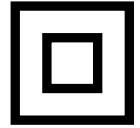

**IMPORTANT:** Servicing a double-insulated product requires extreme care and knowledge of the system, and should be done only by qualified service personnel using identical replacement parts. Always use original factory replacement parts when servicing.

**1. Polarized Plugs.** To reduce the risk of electric shock, this equipment has a polarized plug (one blade is wider than the other). This plug will fit in a polarized outlet only one way. If the plug does not fit fully in the outlet, reverse the plug. If it still does not fit, contact a qualified electrician to install a proper outlet. Do not modify the machine plug or the extension cord in any way.

**2. Ground fault circuit interrupter protection (GFCI)** should be provided on the circuit or outlet used for this power tool to reduce the risk of electric shock.

**3. Service and repair.** To avoid danger, electrical appliances must only be repaired by a qualified service technician using original replacement parts.

## GUIDELINES AND RECOMMENDATIONS FOR EXTENSION CORDS

When using an extension cord, be sure to use one heavy enough to carry the current your product will draw. An undersized cord will cause a drop in line voltage, resulting in loss of power and overheating. The table below shows the correct size to be used according to cord length and ampere rating. When in doubt, use a heavier cord. The smaller the gauge number, the heavier the cord.

AMPERAGE	REQUIRED GAUGE FOR EXTENSION CORDS			
	25 ft.	50 ft.	100 ft.	150 ft.
5A	18 gauge	16 gauge	16 gauge	14 gauge

**1. Examine extension cord before use.** Make sure your extension cord is properly wired and in good condition. Always replace a damaged extension cord or have it repaired by a qualified person before using it.

**2. Do not abuse extension cord.** Do not pull on cord to disconnect from receptacle; always disconnect by pulling on plug. Disconnect the extension cord from the receptacle before disconnecting the product from the extension cord. Protect your extension cords from sharp objects, excessive heat and damp/wet areas.

**3. Use a separate electrical circuit for your tool.** This circuit must not be less than a 12-gauge wire and should be protected with a 15A time-delayed fuse. Before connecting the motor to the power line, make sure the switch is in the OFF position and the electric current is rated the same as the current stamped on the motor nameplate. Running at a lower voltage will damage the motor.



# KNOW YOUR DRYWALL SANDER

## UNPACKING

With the help of a friend or trustworthy foe, such as one of your in-laws, carefully remove the drywall sander from the packaging and place it on a sturdy, flat surface. Make sure to take out all contents and accessories. Do not discard the packaging until everything is removed. Check the packing list below to make sure you have all of the parts and accessories. If any part is missing or broken, please contact customer service at **1-847-429-9263** (M-F 8-5 CST), or email [techsupport@wenproducts.com](mailto:techsupport@wenproducts.com).

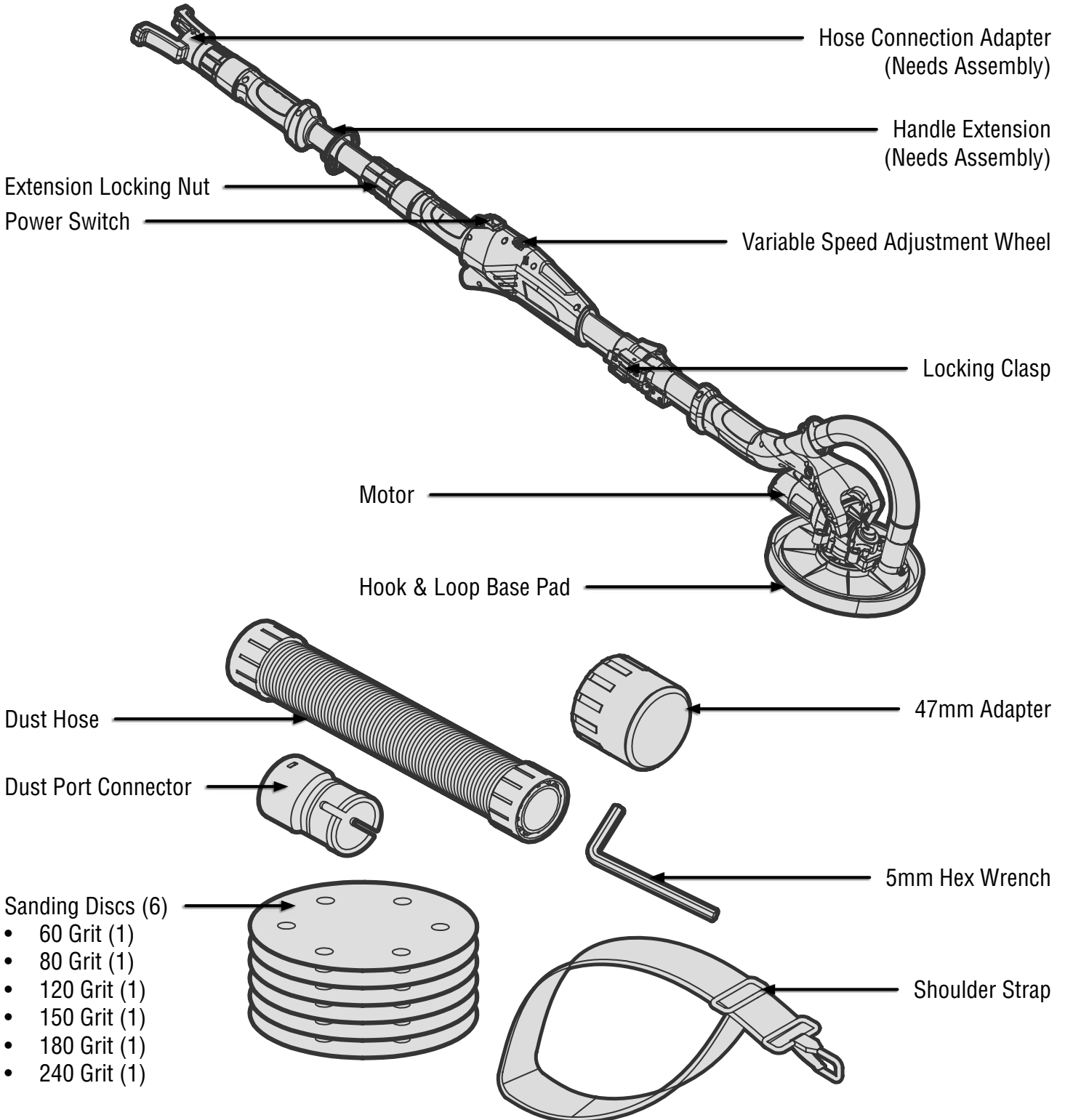

## ASSEMBLY & ADJUSTMENTS

**⚠ WARNING!** To prevent injury from accidental operation, make sure the tool is switched OFF and unplugged from the power source before assembling the tool or making any adjustments.

### ASSEMBLING THE DRYWALL SANDER

1. Unfold the front and back of the drywall sander. Push the locking clasp (Fig. 1 - 1) into the closed position to keep the drywall sander assembly from unfolding.
2. Attach the sanding disk (Fig. 2 - 1) of your choice to the face of the hook and loop base pad (Fig. 2 - 2). Ensure the holes on the sanding disks align with the holes on the bottom of the pad.
3. Attach the optional handle extension (Fig. 3 - 1) by inserting the pole into the main drywall sander. Tighten the extension lock nut (Fig. 3 - 2) to lock the handle extension in place.
4. If you would like to use a dust collection device, screw the hose connection port (Fig. 4 - 1) into the end of the additional handle extension. If you choose not to use the handle extension, attach the hose connection port directly into the end of the main drywall sander assembly.
5. Connect one end of the dust hose to the end of the hose connection port and another to the dust extraction device of your choice.

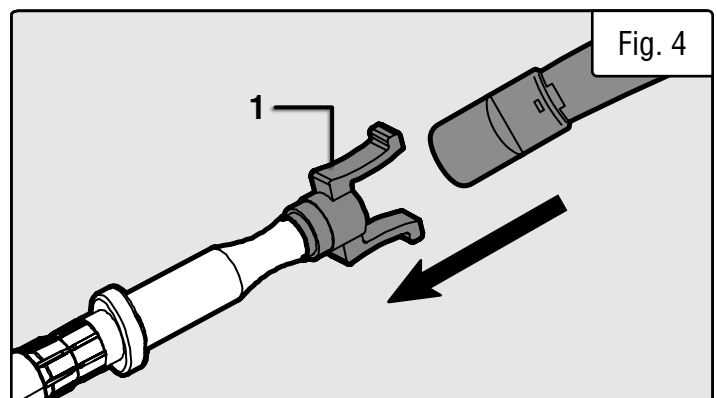
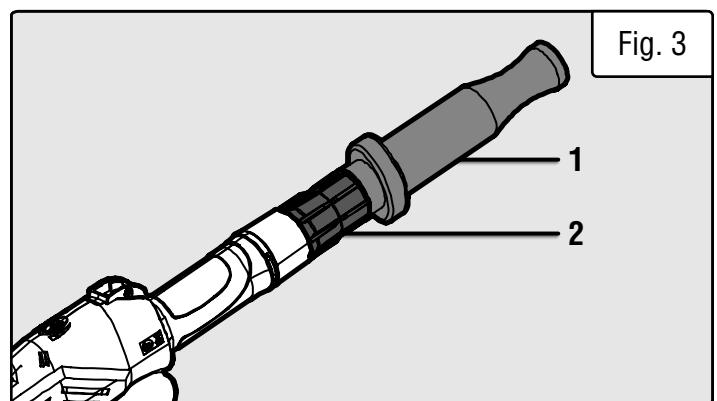
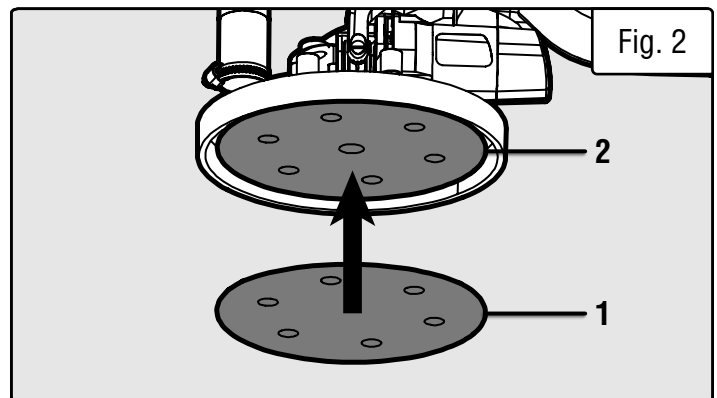
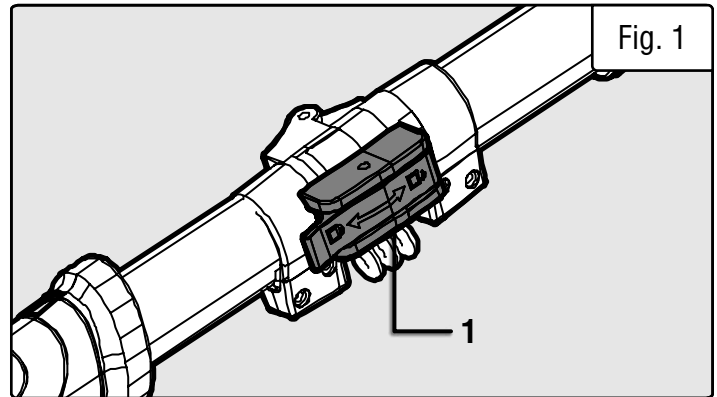

## OPERATION

### OPERATING THE DRYWALL SANDER

1. Hold the machine with both hands.
2. Do not hold the machine by the machine's head.
3. Before operation, make sure every fastener and nut has been properly engaged and that the sanding pad has been properly installed and aligned.
4. Before switching on the machine, keep the sanding head slightly away from the work surface.
5. Do not press down too hard in order to avoid overloading the sander. Use proper pressure for better sanding effects. If the machine slows or bogs down, immediately lessen the applied pressure. The quality of the results are mainly determined by choosing the right abrasive material for the job.
6. Once the sanding task has been completed, turn off the machine. Wait for the pad to stop rotating before setting down the machine.

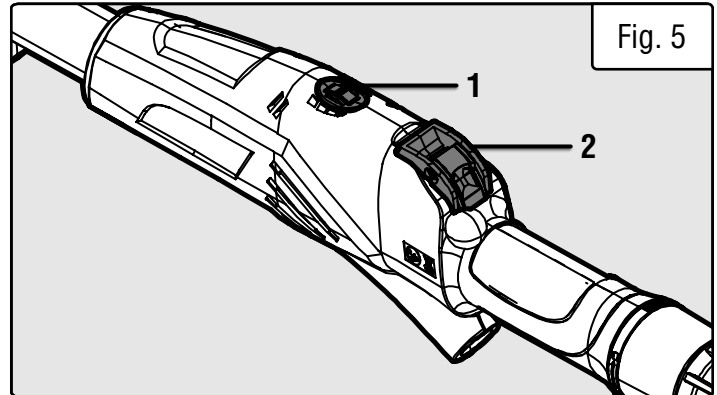

Fig. 5

### VARIABLE SPEED CONTROL

Use the speed wheel (Fig. 5 - 1) to adjust anywhere from 600 to 1500 RPM. This drywall sander is equipped with constant speed control to keep the pad running at a consistent rate despite changes in applied load.

### TURNING ON THE DRYWALL SANDER

After setting the variable speed to your desired RPM, power the machine by pressing forward on the power switch (Fig. 5 - 2).

## MAINTENANCE

### REPLACING THE SANDING PAD

Insert the hex wrench into the hexagonal screw (Fig. 6 - 1) located in the center of the hook and loop sanding pad. Hold the pad firmly while turning the wrench to unscrew the center hex screw. Replace the pad with an identical part suited for this particular model of drywall sander. Attach firmly in place using the hexagonal screw.

### CLEANING YOUR DRYWALL SANDER

Your drywall sander requires no additional lubrication or maintenance. Always store your sander in a dry place away from children. If the supply cord is damaged, it must be replaced by the manufacturer or a similarly qualified technician. Do not use a damaged tool.

If excessive sparking occurs, have the carbon brushes checked by a qualified electrician. Only a qualified technician should change the carbon brushes.

Clean the unit immediately after using it. Regularly clean the unit with a damp cloth and a little soft soap. Do not use cleaners or solvents as they will attack the plastic of the unit. Make sure water does not get into the unit.

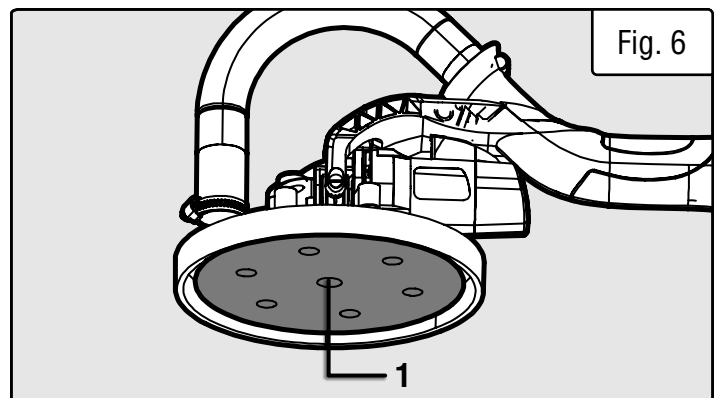

Fig. 6

## **TROUBLESHOOTING GUIDE**

**⚠ WARNING!** Stop using the tool immediately if any of the following problems occur or risk serious personal injury. If you have any questions, please contact customer service at **1-847-429-9263** (M-F 8-5 CST), or email [techsupport@wenproducts.com](mailto:techsupport@wenproducts.com).

<b>PROBLEM</b>	<b>CAUSE</b>	<b>SOLUTION</b>
<b>Motor is not working.</b>	<ol style="list-style-type: none"> <li>1. Wires in the main plug or in the socket are loose.</li> <li>2. The switch is faulty.</li> </ol>	<ol style="list-style-type: none"> <li>1. Have the socket and plug checked by an authorized technician.</li> <li>2. Have the switch replaced by an authorized technician.</li> </ol>
<b>Unusual noises occur during operation. Motor is not working properly.</b>	<ol style="list-style-type: none"> <li>1. Switch contact has failed.</li> <li>2. Components have jammed.</li> <li>3. Too high of load has been applied.</li> </ol>	<ol style="list-style-type: none"> <li>1. Have the switch replaced by an authorized technician.</li> <li>2. Have the tool checked and repaired.</li> <li>3. Use less pressure during sanding operations.</li> </ol>
<b>Motor gets hot.</b>	<ol style="list-style-type: none"> <li>1. Foreign substances have gotten inside the motor.</li> <li>2. Too high of load has been applied.</li> </ol>	<ol style="list-style-type: none"> <li>1. Have the foreign substances removed.</li> <li>2. Use less pressure during sanding operations.</li> </ol>
<b>Frequent sparks occur on the commutator.</b>	<ol style="list-style-type: none"> <li>1. There is a short circuit in the motor (armature).</li> <li>2. Carbon brushes are worn out or jammed.</li> </ol>	<ol style="list-style-type: none"> <li>1. Have the armature replaced.</li> <li>2. Have the carbon brushes checked.</li> </ol>

# EXPLODED VIEW & PARTS LIST

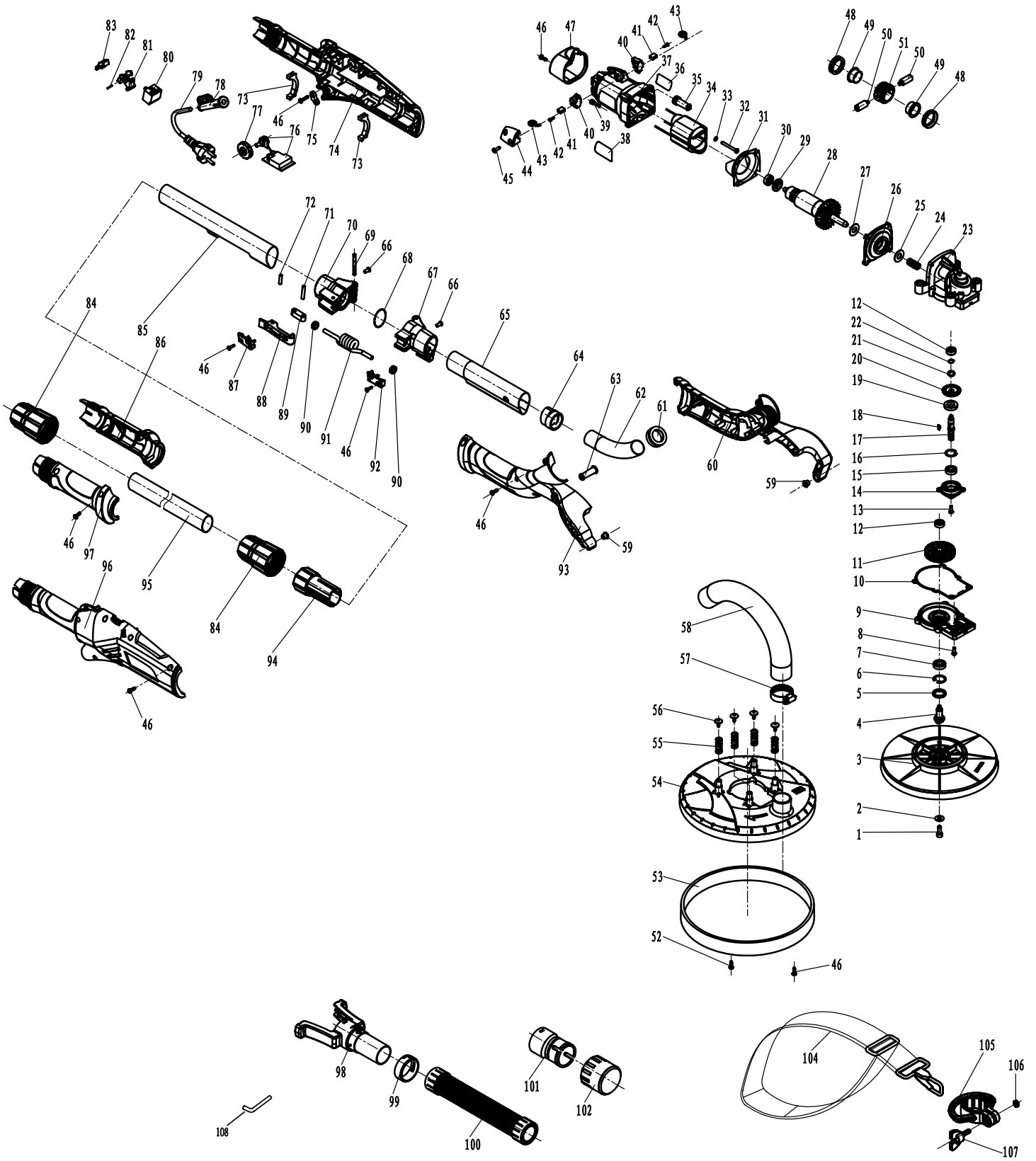

**NOTE:** Not all parts may be available for purchase. Parts and accessories that wear down over the course of normal use are not covered under the warranty.

## **EXPLODED VIEW & PARTS LIST**

No.	Part No.	Description	Qty.
1	6369-001	M6x15 Screw	1
2	6369-002	Ø6 Washer	1
3	DW5062-003	Sanding Pad	1
4	6369-004	Output Shaft	1
5	6369-006	Oil Seal	1
6	6369-007	Collar Ø22	1
7	6369-008	Ball Bearing 6900 RS	1
8	DW5062-008	Screw M4x16	6
9	6369-010	Bearing Cover	1
10	6369-011	Paper Washer	1
11	6369-012	End Gear	1
12	6369-014	Ball Bearing 606 Z	2
13	6369-009	Screw M4x12	4
14	6369-015	Small Bearing Cover	1
15	6369-016	Ball Bearing 699 Z	1
16	6369-017	Collar Ø22	1
17	6369-018	Main Driving Shaft	1
18	6369-020	Semi-Circular Key 3X3X10	1
19	6369-019	Washer	1
20	6369-021	Tapered Gear	1
21	6369-022	Washer	1
22	6369-023	Collar Ø9	1
23	6369-024	Gear Box	1
24	6369-026	Rotor Coil	1
25	6369-027	Wool Cap	1
26	6369-025	Middle Cover	1
27	DW5062-027	Anti-Dust Washer	1
28	6369-028	Rotor	1
29	6369-029	Anti-Dust Ring	1
30	6369-030	Ball Bearing 607 RS	1
31	6369-031	Anti-Wind Ring	1
32	6369-032	Screw ST4x55	2
33	6369-033	Washer	1
34	6369-034	Stator	1
35	6369-035	Sleeve	1
36	DW5062-036	Logo Label	1
37	6369-036	Motor Housing	1

No.	Part No.	Description	Qty.
38	DW5062-038	Specification Label	1
39	6369-039	Screw M4x20	4
40	6369-040	Brush Holder	2
41	6369-041	Carbon Brush	2
42	6369-042	Screw ST3x10	2
43	6369-043	Coil Spring	2
44	6369-047	Pressing Block On Motor Housing	1
45	6369-045	Screw ST4x12	2
46	6369-046	Screw ST4x14	37
47	6369-044	Back Cover	1
48	6369-048	Vibration Damping	2
49	6369-049	Rubber Sleeve	2
50	6369-050	Screw Pin	2
51	6369-051	Flexible Sleeve	1
53	6369-052	Brush Segment	1
54	6369-053	Sanding Pad Cover	1
55	6369-064	Compressed Spring	4
56	6369-063	Washer Ø4	4
57	6369-054	Hose Clamp 25-38	1
58	6369-055	350 Hose	1
59	6369-057	Small Rubber Cover	2
60	6369-062	Left Handle Stand	1
61	6369-059	Ø28 Connector	1
62	6369-060	Plastic Soft Pipe Ø28	1
63	6369-056	Cable Sleeve	1
64	6369-061	Ellipticle Connector	1
65	6369-083	Aluminium Pipe	1
66	6369-080	Ø5 Clinch Bolt	2
67	6369-082	Front Hinge	1
68	6369-081	Ø1.2 Sealed Ring	1
69	6369-079	Ø5x45 Pin	1
70	6369-078	Back Hinge	1
71	6369-085	Pin Ø5x30	1
72	6369-086	Pin Ø5x16.8	1
73	6369-066	Cable Plate	2
74	6369-073	Left Main Handle	1
75	6369-075	Cable Pressing Plate	1
76	6369-069	Potentiometer	1

## **EXPLODED VIEW & PARTS LIST**

No.	Part No.	Description	Qty.
77	6369-070	Speed Button	1
78	6369-072	Cable Sleeve	1
79	6369-071	Cable	1
80	6369-093	Switch	1
81	6369-094	Switch Pushing Lever	1
82	6369-097	Circular Pin Ø1.5x11.8	1
83	6369-095	Switch Button	1
84	6369-098	Back Screw Nut	2
85	6369-077	Aluminium Pipe	1
86	6369-076	Left Sub-Handle	1
87	6369-090	Latch Pivot	1
88	6369-091	Fixed Plate	1
89	6369-084	Supporting Arm	1
90	6369-087	Sleeve	2
91	6369-089	Spring	1
92	6369-088	Front Latch	1
93	6369-058	Right Handle Stand	1

No.	Part No.	Description	Qty.
94	6369-074	Aluminium Pipe Insert	1
95	6369-092	Aluminium Pipe	1
96	6369-099	Right Main Handle	1
97	6369-096	Right Sub-Handle	1
98	6369-100	Hose Connection Adapter	1
99	6369-101	Adjustable Ring	1
100	6369-103	Flexible Hose	1
101	6362-054	Middle Connector	1
102	DW5062-102	Ø47 Vacuum Adapter	1
104	DW5062-104	Shoulder Strap with hook	1
105	DW5062-105	Hook Seat	1
106	DW5062-106	Nut M5	1
107	DW5062-107	Bolt M5x18	1
108	DW5062-108	Hex Wrench S5	1

**NOTE:** Not all parts may be available for purchase. Parts and accessories that wear down over the course of normal use are not covered under the warranty.

# **WARRANTY STATEMENT**

WEN Products is committed to building tools that are dependable for years. Our warranties are consistent with this commitment and our dedication to quality.

## **LIMITED WARRANTY OF WEN PRODUCTS FOR HOME USE**

GREAT LAKES TECHNOLOGIES, LLC (“Seller”) warrants to the original purchaser only, that all WEN consumer power tools will be free from defects in material or workmanship during personal use for a period of two (2) years from date of purchase or 500 hours of use; whichever comes first. Ninety days for all WEN products if the tool is used for professional or commercial use. Purchaser has 30 days from the date of purchase to report missing or damaged parts.

SELLER’S SOLE OBLIGATION AND YOUR EXCLUSIVE REMEDY under this Limited Warranty and, to the extent permitted by law, any warranty or condition implied by law, shall be the replacement of parts, without charge, which are defective in material or workmanship and which have not been subjected to misuse, alteration, careless handling, misrepair, abuse, neglect, normal wear and tear, improper maintenance, or other conditions adversely affecting the Product or the component of the Product, whether by accident or intentionally, by persons other than Seller. To make a claim under this Limited Warranty, you must make sure to keep a copy of your proof of purchase that clearly defines the Date of Purchase (month and year) and the Place of Purchase. Place of Purchase must be a direct vendor of Great Lakes Technologies, LLC. Purchasing through third party vendors, including but not limited to garage sales, pawn shops, resale shops, or any other secondhand merchant, voids the warranty included with this product. Contact [techsupport@wenproducts.com](mailto:techsupport@wenproducts.com) or 1-847-429-9263 with the following information to make arrangements: your shipping address, phone number, serial number, required part numbers, and proof of purchase. Damaged or defective parts and products may need to be sent to WEN before the replacements can be shipped out.

Upon the confirmation of a WEN representative, your product may qualify for repairs and service work. When returning a product for warranty service, the shipping charges must be prepaid by the purchaser. The product must be shipped in its original container (or an equivalent), properly packed to withstand the hazards of shipment. The product must be fully insured with a copy of the proof of purchase enclosed. There must also be a description of the problem in order to help our repairs department diagnose and fix the issue. Repairs will be made and the product will be returned and shipped back to the purchaser at no charge for addresses within the contiguous United States.

THIS LIMITED WARRANTY DOES NOT APPLY TO ITEMS THAT WEAR OUT FROM REGULAR USAGE OVER TIME, INCLUDING BELTS, BRUSHES, BLADES, BATTERIES, ETC. ANY IMPLIED WARRANTIES SHALL BE LIMITED IN DURATION TO TWO (2) YEARS FROM DATE OF PURCHASE. SOME STATES IN THE U.S. AND SOME CANADIAN PROVINCES DO NOT ALLOW LIMITATIONS ON HOW LONG AN IMPLIED WARRANTY LASTS, SO THE ABOVE LIMITATION MAY NOT APPLY TO YOU.

IN NO EVENT SHALL SELLER BE LIABLE FOR ANY INCIDENTAL OR CONSEQUENTIAL DAMAGES (INCLUDING BUT NOT LIMITED TO LIABILITY FOR LOSS OF PROFITS) ARISING FROM THE SALE OR USE OF THIS PRODUCT. SOME STATES IN THE U.S. AND SOME CANADIAN PROVINCES DO NOT ALLOW THE EXCLUSION OR LIMITATION OF INCIDENTAL OR CONSEQUENTIAL DAMAGES, SO THE ABOVE LIMITATION OR EXCLUSION MAY NOT APPLY TO YOU.

THIS LIMITED WARRANTY GIVES YOU SPECIFIC LEGAL RIGHTS, AND YOU MAY ALSO HAVE OTHER RIGHTS WHICH VARY FROM STATE TO STATE IN THE U.S., PROVINCE TO PROVINCE IN CANADA AND FROM COUNTRY TO COUNTRY.

THIS LIMITED WARRANTY APPLIES ONLY TO ITEMS SOLD WITHIN THE UNITED STATES OF AMERICA, CANADA AND THE COMMONWEALTH OF PUERTO RICO. FOR WARRANTY COVERAGE WITHIN OTHER COUNTRIES, CONTACT THE WEN CUSTOMER SUPPORT LINE. FOR WARRANTY PARTS OR PRODUCTS REPAIRED UNDER WARRANTY SHIPPING TO ADDRESSES OUTSIDE OF THE CONTIGUOUS UNITED STATES, ADDITIONAL SHIPPING CHARGES MAY APPLY.