

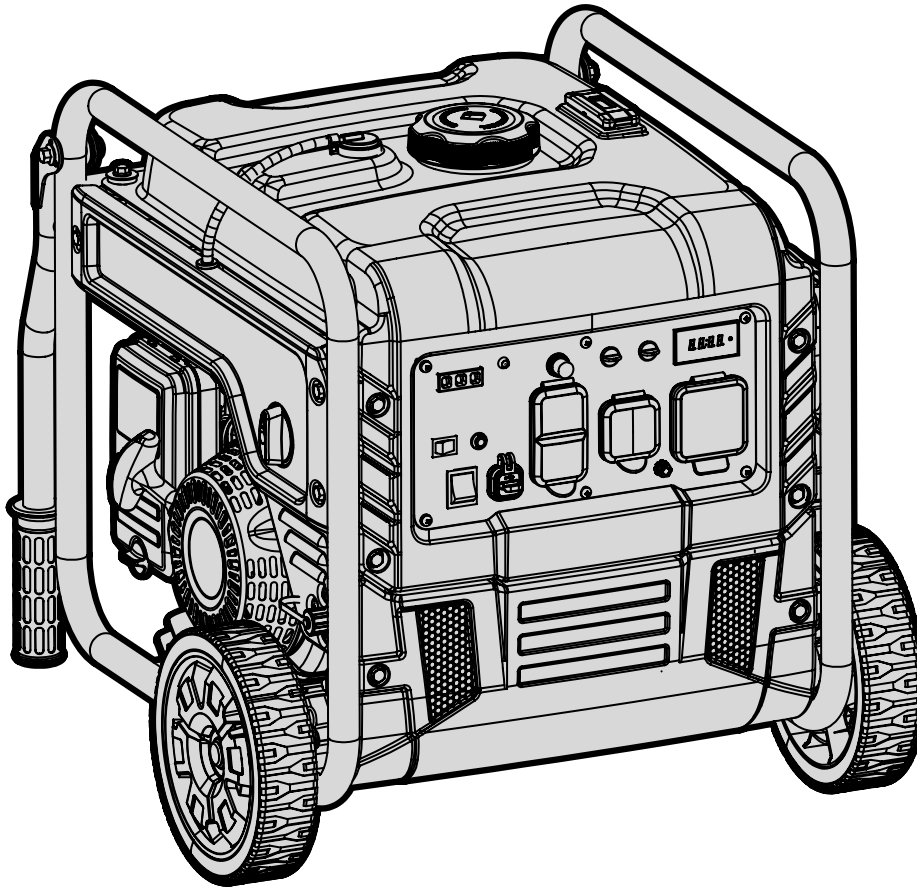

MODEL DG4500iX

4500W DUAL FUEL INVERTER GENERATOR

Instruction Manual



NEED HELP? CONTACT US!

Have product questions? Need technical support? Please feel free to contact us:

 **1-800-232-1195 (M-F 8AM-5PM CST)** |  **TECHSUPPORT@WENPRODUCTS.COM**

IMPORTANT: Your new tool has been engineered and manufactured to WEN's highest standards for dependability, ease of operation, and operator safety. When properly cared for, this product will supply you years of rugged, trouble-free performance. Pay close attention to the rules for safe operation, warnings, and cautions. If you use your tool properly and for its intended purpose, you will enjoy years of safe, reliable service.

For replacement parts and the most up-to-date instruction manuals, visit ***WENPRODUCTS.COM***

CONTENTS

| | |
|------------------------------------|-----------|
| WELCOME | 3 |
| Specifications..... | 3 |
| Introduction | 4 |
| | |
| SAFETY | 5 |
| Safety Information | 5 |
| Generator Safety Warnings | 6 |
| | |
| BEFORE OPERATING | 9 |
| Unpacking & Packing List | 9 |
| Know Your Inverter Generator..... | 10 |
| Assembly & Adjustments..... | 12 |
| Generator Preparation..... | 12 |
| | |
| OPERATION & MAINTENANCE | 19 |
| Starting Your Generator | 19 |
| Using Your Generator..... | 22 |
| Shutting Off Your Generator..... | 29 |
| Maintenance..... | 31 |
| Transportation & Storage..... | 39 |
| Troubleshooting Guide..... | 40 |
| Wiring Diagram..... | 41 |
| Exploded View & Parts List..... | 42 |
| Warranty Statement | 49 |

To purchase accessories for your tool, visit ***WENPRODUCTS.COM***

WEN Parallel Connection Kit

Weatherproof Generator Cover, Medium (Model 56406)

High-Altitude Kit (Part DG4500iX-HA36 and DG4500iX-HA69)

SPECIFICATIONS

GENERATOR

| | |
|--------------------|--|
| Rated Wattage | Gasoline: 3650 Watts; LPG: 3285 Watts |
| Surge Wattage | Gasoline: 4500 Watts; LPG: 4500 Watts |
| Rated Voltage | AC: 120V |
| | DC: 5V (USB) |
| Rated Amperage | AC: 30.4A Total (Total), 30A (TT-30R), 20A (5-20R), 30A (L5-30R) |
| | DC: 2.1A / 2.1A (USB) |
| Phase | Single |
| Frequency | 60Hz |
| Decibel Rating | 68 dBA (25% load from 22 feet away) |
| Product Dimensions | With Wheel Kit: 22-3/4 in. x 22-3/4 in. x 21-1/2 in. |
| | Without Wheel Kit: 20-3/4 in. x 18 in. x 18-3/4 in. |
| Product Net Weight | With Wheel Kit: 90.8 Pounds |
| | Without Wheel Kit: 83.8 Pounds |

ENGINE

| | |
|---------------------|---|
| Engine Type | 4-Stroke, OHV, Single Cylinder with Forced Air Cooling System |
| Engine Displacement | 224cc |
| Engine Speed | 3600 RPM |
| Fuel Tank Capacity | 4 gal (15.20 L), 87 Octane Minimum |
| Oil Capacity | 20 fl. oz. (0.60 L) |
| Half-Load Run Time | 12 Hours (Gasoline), 12 Hours (20 lb LPG tank) |
| Lubrication System | Splash Lubrication |
| Spark Plug Type | F6RTC |
| Spark Plug Gap | 0.6 - 0.8 mm (0.024 - 0.031 in.) |
| Spark Plug Torque | 1/2 - 3/4 turn after gasket contacts base or 15 ft-lbs |
| Battery | 12V, 7Ah, Lead-Acid |

INTRODUCTION

Thanks for purchasing the WEN 4500-Watt Dual-Fuel Inverter Generator. Refer to the illustration below for the location of the serial number on the specifications label. Record the generator information in the spaces provided below. If assistance for information or service is required, please contact customer service by calling **1-800-232-1195**, M-F 8-5 CST; you will be asked to provide the following generator information when calling.

Generator Model Number: DG4500iX

Date of Purchase: _____

Purchased From: _____

Serial Number: _____



**4500-WATT
DUAL FUEL INVERTER GENERATOR**

MODEL DG4500iX

| | | | |
|-------------------|-----------------------|-----------------|---------------------|
| RATED WATTAGE | GAS: 3650W LPG: 3285W | RATED FREQUENCY | 60 Hz |
| SURGE WATTAGE | GAS: 4500W LPG: 4500W | RATED VOLTAGE | AC: 120V DC: 5V |
| SERIAL NO. | | OIL CAPACITY | 20 fl. oz. (0.60 L) |
| ENGINE SERIAL NO. | | FUEL TANK | 4 gal (15.20 L) |

1-800-232-1195 WENPRODUCTS.COM

Great Lakes Technologies LLC • 1101 Wesemann Drive • West Dundee, IL 60118

MADE IN CHINA

TYPE 1

Serial Number →

SERVICE RECORD

Record the service dates of your generator in the chart below. Please perform maintenance checks and operations according to the “Maintenance” section of the manual.

| Service Record | Date | Date | Date | Date | Date | Date |
|----------------------|------|------|------|------|------|------|
| Change Oil | | | | | | |
| Change Spark Plug | | | | | | |
| Clean Fuel Tank | | | | | | |
| Clean Air Filter | | | | | | |
| Clean Spark Arrestor | | | | | | |

TO MAXIMIZE THE LIFESPAN OF YOUR GENERATOR: We recommend running your generator at least once a month for 20 to 30 minutes. Start the generator according to the instructions and plug a small load in to make sure the outlet is producing electricity.

SAFETY INFORMATION

 **WARNING!** Before operating the generator, make sure to read all safety warnings and all instructions. Failure to follow the warnings and instructions may result in electric shock, fire or serious injury.

SAFETY INTRODUCTION

Safety is a combination of common sense, staying alert, and knowing how your tool works. This manual contains important information regarding the generator's potential safety concerns, as well as preparation, operation, and maintenance instructions. Before operating this generator, be sure to read and observe all warnings and instructions both on the generator labels and in this instruction manual. Failure to follow all instructions listed below may result in personal injury.

NOTE: The following safety information is not meant to cover all possible conditions and situations that may occur. WEN reserves the right to change this product and specifications at any time without prior notice.

At WEN, we are continuously improving our products. If you find that your tool does not exactly match this manual, please visit wenproducts.com for the most up-to-date manual or contact customer service at **1-800-232-1195**, M-F 8-5 CST.

Keep this manual available to all users during the entire life of the tool and review it frequently to maximize safety for both yourself and others.

SAVE THESE SAFETY INSTRUCTIONS.

SAFETY SYMBOLS

The purpose of following safety symbols is to attract your attention to possible dangers. The safety symbols, and their explanations, deserve your careful attention and understanding. The safety warnings do not by themselves eliminate any danger. The instructions or warnings they give are not substitutes for proper accident prevention measures.

 **DANGER:** indicates a hazard, which, if not avoided, will result in death or serious injury.

 **WARNING:** indicates a hazard, which, if not avoided, could result in death or serious injury.

 **CAUTION:** indicates a hazard, which, if not avoided, might result in minor or moderate injury.

CAUTION! when used without the alert symbol, indicates a situation that could result in damage to the machine.

NOTICE REGARDING EMISSIONS

Engines that are certified to comply with U.S. EPA emission regulations for SORE (Small Off Road Equipment), are certified to operate on regular unleaded gasoline, and may include the following emission control systems: (EM) Engine Modifications and (TWC) Three-Way Catalyst (if so equipped).

QUESTIONS? PROBLEMS?

In order to answer questions and solve problems in the most efficient and speedy manner, contact customer service at **1-800-232-1195**, M-F 8-5 CST or email techsupport@wenproducts.com.

GENERATOR SAFETY WARNINGS

DANGER! CARBON MONOXIDE

Using a generator indoors **CAN KILL YOU IN MINUTES**. Generator exhaust contains carbon monoxide (CO). This is a poison gas you cannot see or smell. If you can smell the generator exhaust, you are breathing CO. But even if you cannot smell the exhaust, you could be breathing CO.





NEVER use a generator inside homes, garages, crawl spaces, or other partially enclosed areas. Deadly levels of carbon monoxide can build up in these areas. Using a fan or opening windows and doors does **NOT** supply enough fresh air. **ONLY** use a generator outside and far away from windows, doors, and vents. These openings can pull in generator exhaust.

Even if you use a generator correctly, CO may leak into the home. **ALWAYS** use a battery-powered or battery-backup CO alarm in the home. If you start to feel sick, dizzy, or weak after the generator has been running, move to fresh air **RIGHT AWAY**. See a doctor. You may have carbon monoxide poisoning.

 **WARNING! RISK OF EXPLOSION. HIGHLY FLAMMABLE:** This generator may emit highly flammable and explosive gasoline vapors, which can cause severe burns or even death, if ignited. A nearby open flame can lead to explosion even if not directly in contact with gasoline.

- Do not operate near open flame, heat, or any other ignition source. Do not smoke near the generator.
- Always operate on a firm, level surface.
- Always turn generator off before refueling. Allow generator to cool for at least 2 minutes before removing fuel cap. Loosen cap slowly to relieve pressure in tank.
- Do not overfill fuel tank. Gasoline may expand during operation. Do not fill to the top of the tank. Allow for expansion. Always check for spilled fuel before operating.
- If fuel spills, move the generator at least 30 feet away from the spill and wipe clean any spilled fuel before starting the engine.
- Empty fuel tank before storing or transporting the generator.

 **WARNING!** If this generator is used as a supply for a building's wiring system, the generator must be installed by a qualified electrician and connected to a transfer switch as a separately derived system in accordance with all applicable laws and electrical codes and the National Electrical Code, NFPA 70. The generator shall be connected to a transfer switch that switches all conductors excluding the equipment grounding conductor. The frame of the generator shall be connected to an approved grounding electrode.

 **CALIFORNIA PROPOSITION 65 WARNING:** This product contains chemicals and produces exhaust known to the State of California to cause cancer, birth defects and other reproductive harm.

GENERATOR SAFETY WARNINGS

 **WARNING!** Do not let comfort or familiarity with the product replace strict adherence to product safety rules. Failure to follow the safety instructions may result in serious personal injury.

OPERATING ENVIRONMENT

1. **Using a generator indoors can kill you in minutes.** Only use a generator outside and far away from windows, doors and vents.

2. **Do not smoke near the generator.**

3. **Do not operate near open flame, heat, or flammable materials.** This generator may emit highly flammable and explosive gasoline vapors, which can cause severe burns or even death if ignited. A nearby open flame can lead to an explosion even if it isn't directly in contact with gasoline.

4. **Do not expose the generator to rainy or wet conditions; doing so significantly increases the risk of electrical shock.** Never handle the generator, electronic devices, or any cord while standing in water, while barefoot, or when hands or feet are wet.

5. **Always operate the generator on a dry, firm, level surface.**

6. **The generator should have at least 5 feet of clearance from buildings or other equipment during operation.**

7. **Do not allow children or non-qualified persons to operate the generator.**

GENERATOR PREPARATION

1. **Always ground the generator before using it to maximize safety** (see "Ground the Generator" section).

2. **Do not overfill fuel tank, as gasoline may expand during operation.** Do not fill to the very top of the tank. Leave room for gasoline expansion. Always check for spilled fuel before operating.

3. **If any part of the generator, electrical device or power cord is broken, damaged, or defective, make sure it is repaired or replaced before operation.** Service should only be performed by a qualified technician. Do not use receptacles or cords that show signs of damage, such as broken or cracked insulation.

4. **Use a ground fault circuit interrupter (GFCI) in highly conductive areas such as metal decking or steel work.** Extension cords with in-line GFCIs are recommended for these operations to maximize safety.

5. **If connecting the generator to a building's electrical system for standby power, you MUST consult a qualified electrician and install a transfer switch.** Such connections must comply with local electrical laws and codes. Failure to comply can create a back-feed, which may result in serious injury or death to utility workers.

6. **Never modify the generator in any way.** Modifying or using the machine for any other purpose for which it is not designed may result in serious injuries, machine damage and voiding of the warranty.

GENERATOR OPERATION

1. **Only use the generator for its intended purposes.** Modifying or using the generator for operations for which it was not designed may cause hazards and personal injury.

2. **Do not touch bare wires or receptacles (outlets).**

3. **Do not exceed the wattage capacity of the generator by plugging in more electrical devices than the unit can handle.** This could damage the generator and/or connected electrical devices. Check the operating voltage and frequency requirements of all electrical devices prior to plugging them into the generator.

Generator safety warnings continue on the next page.

GENERATOR SAFETY WARNINGS

 **WARNING!** Do not let comfort or familiarity with the product replace strict adherence to product safety rules. Failure to follow the safety instructions may result in serious personal injury.

TO MAXIMIZE THE LIFESPAN OF YOUR GENERATOR: We recommend running your generator at least once a month for 20 to 30 minutes. Start the generator according to the instructions and plug a small load in to make sure the outlet is producing electricity. If you do not run it often, it will greatly shorten the generator's lifespan and void the warranty.

4. **Allow generator to run for several minutes before connecting electrical devices.** Do not start or stop engine with electrical devices plugged in to the receptacles. Failure to do so could damage the generator and/or connected electrical devices.
5. **Do not turn on electrical devices until after they are connected to the generator.**
6. **Generators vibrate in normal use.** During and after the use of the generator, inspect both the generator as well as extension and power supply cords for damage resulting from vibration.
7. **Do not touch hot parts.** This generator produces heat when running. Temperatures near exhaust can exceed 150°F (65°C). Allow generator to cool down after use before touching engine or areas of the generator that become hot during use.
8. **Turn off all connected electrical devices before stopping the generator.**
9. **Always turn generator off before refueling.** Allow generator to cool for at least 2 minutes before removing fuel cap. Loosen cap slowly to relieve pressure in tank.
10. **Turn the engine switch and fuel selector knob to "OFF" position when the engine is not running.**
11. **Empty fuel tank before storing or transporting the generator.** Do not store generator or gasoline near furnaces, water heaters, or any other appliances that produce heat or have automatic ignitions. Store the generator and fuel away from sparks, open flames, pilot lights, heat and other sources of ignition.
12. **Always wash hands after handling generator.**









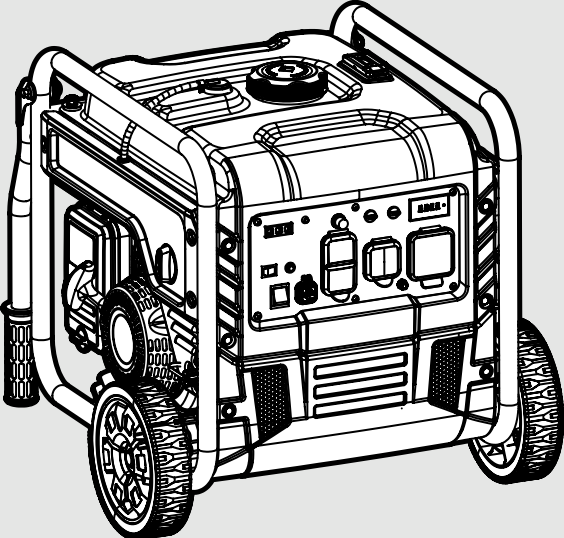

CAUTION: Misuse of this generator can damage it or shorten its lifespan.

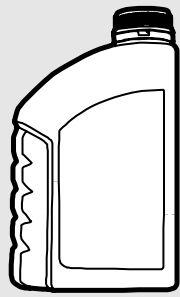
UNPACKING & PACKING LIST

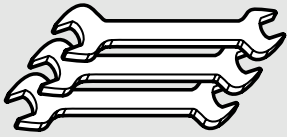
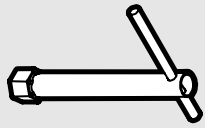
UNPACKING

With the help of a friend or trustworthy foe, such as one of your in-laws, carefully remove the generator from the packaging and place it on a sturdy, flat surface. Make sure to take out all contents and accessories. Do not discard the packaging until everything is removed. Check the packing list below to make sure you have all of the parts and accessories. If any part is missing or broken, please contact customer service at **1-800-232-1195** (M-F 8-5 CST), or email techsupport@wenproducts.com.

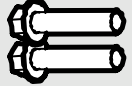
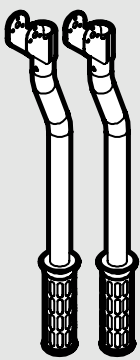
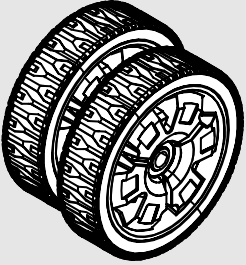
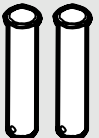
PACKING LIST

| | | |
|---|---|---|
| <p><i>Components</i></p>  <p>Generator</p> | <p><i>Accessories</i></p>  <p>5mm Hex Wrench (1)</p>  <p>Funnel (1)</p>  <p>Engine Oil (20 fl. oz.) (1)</p>  <p>LPG Regulator Hose Assembly (1)</p>  <p>Wrenches (3) (10-12mm, 13-15mm, 19mm)</p>  <p>Spark Plug Socket (1)</p> | |
| <p><i>Foot Support Assembly</i></p>  <p>Support Assembly (1)</p>  <p>M8x6 Bolts (2)</p> | <p><i>Handle Assembly</i></p>  <p>M8 Nuts (2)</p>  <p>M8x40 Bolts (2)</p>  <p>Handle Assemblies (2)</p> | <p><i>Wheel Assembly</i></p>  <p>Wheels (2)</p>  <p>Axle Pins (2)</p>  <p>R-Clips (2)</p> |

KNOW YOUR INVERTER GENERATOR

TOOL PURPOSE

Inverter Generators provide you with clean and quiet power, when and where you need it most. Refer to the following diagrams to become familiarized with all the parts and controls of your Generator. The components will be referred to later in the manual for assembly and operation instructions.

GENERATOR

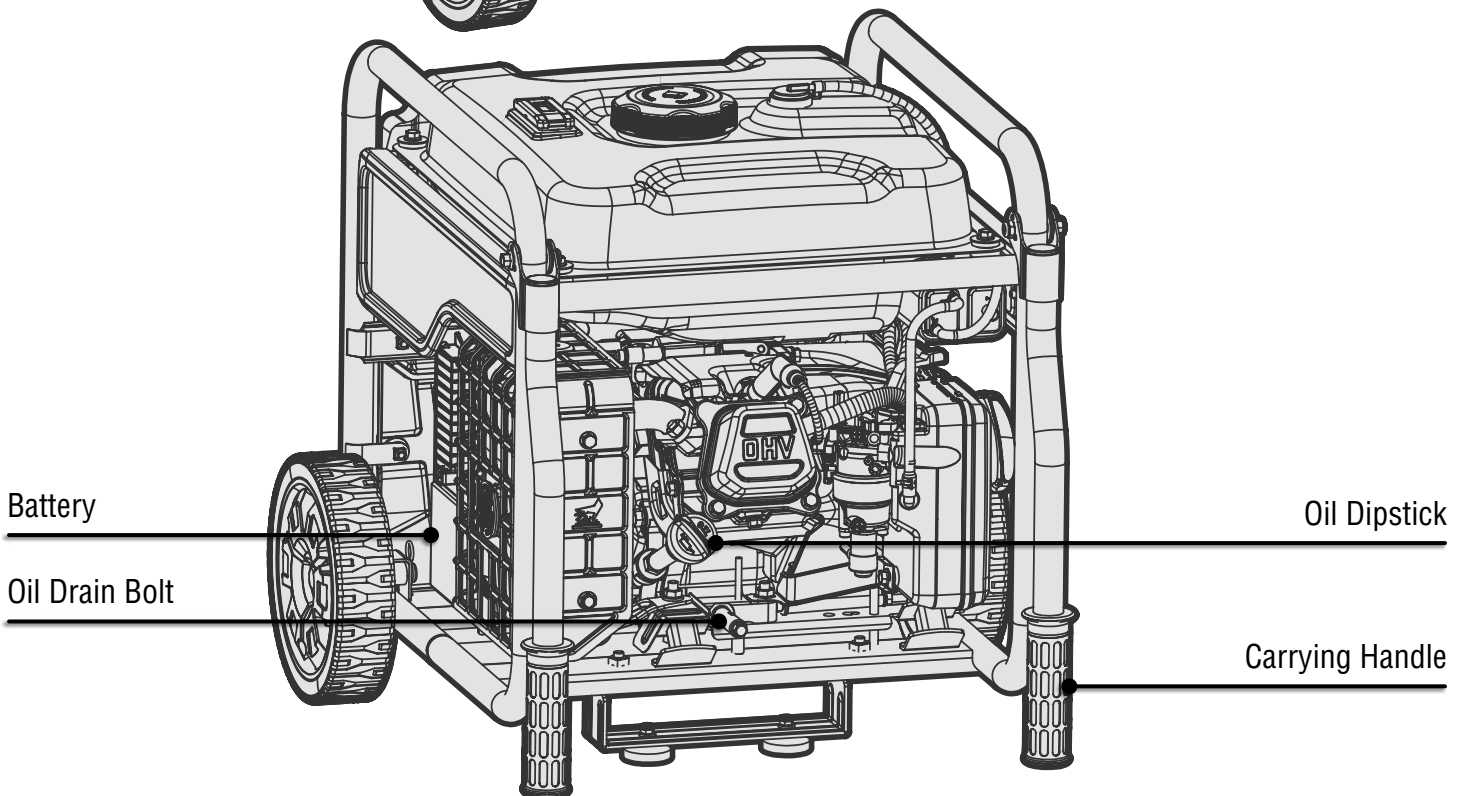
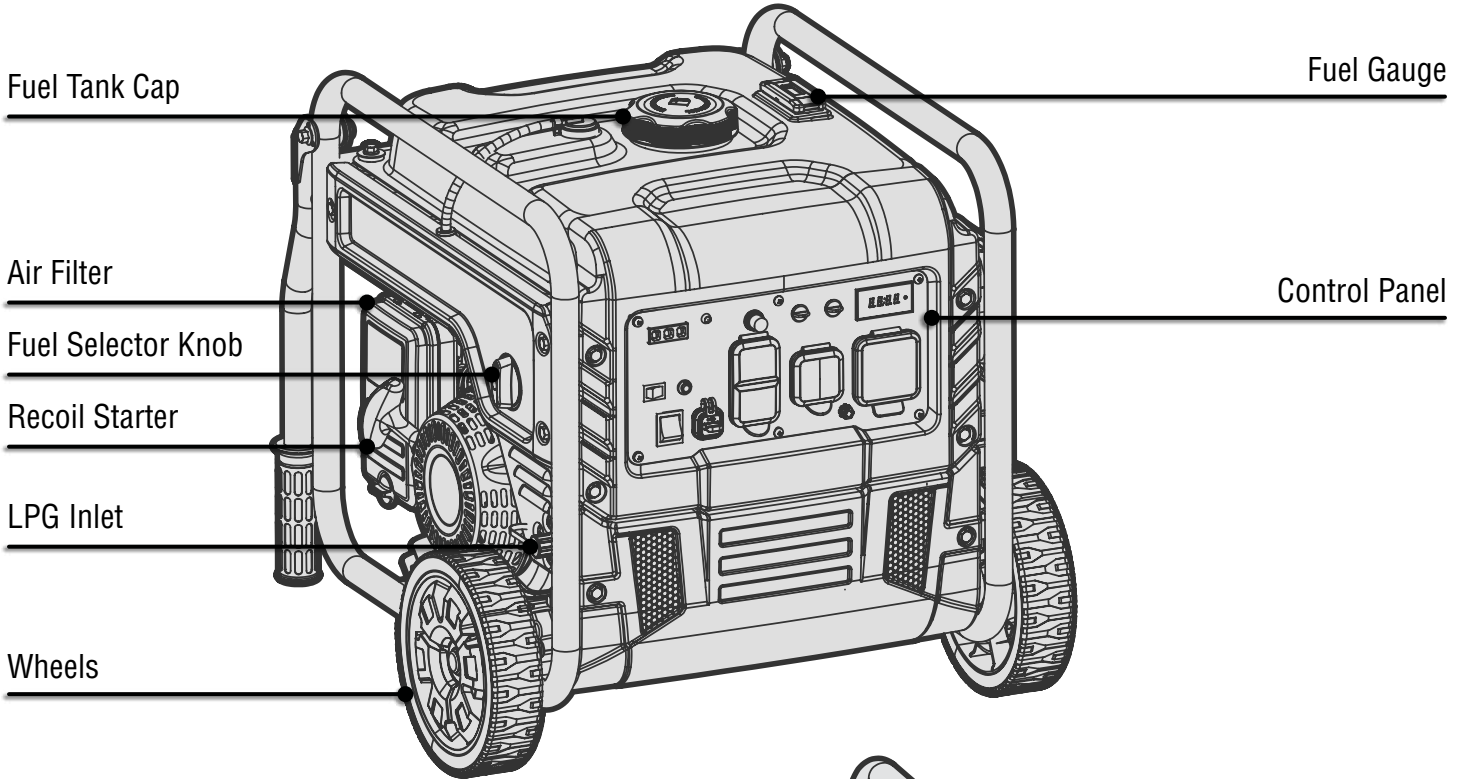

KNOW YOUR INVERTER GENERATOR

CONTROL PANEL

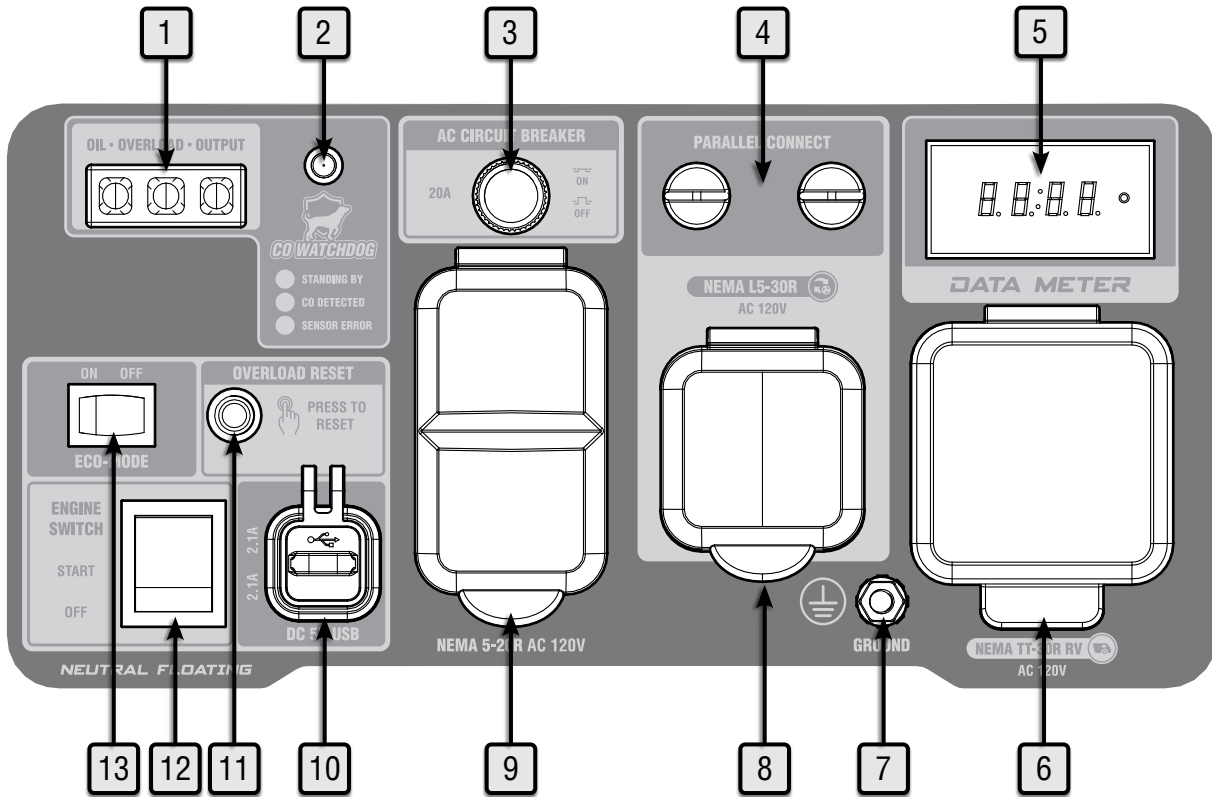

1. Indicator Lights

The oil light (yellow) will turn on if the oil is low, the overload light (red) will turn on if the generator is overloaded, and the output light (green) will turn on when the receptacles have power.

2. CO WATCHDOG Carbon Monoxide Monitor

Measures the accumulation of poisonous CO gas while the generator is running. If the level of CO gas gets too high, the CO Watchdog system will automatically shut down the generator. See p. 28 for more information.

3. AC Circuit Breaker (20A)

4. Parallel Connection Port

Connect two WEN inverter generators through a parallel connection kit for more output.

5. Data Meter

Displays voltage, frequency, total runtime (HHHH), and session runtime (HH:MM). Press the MODE button to switch between displays.

6. AC 120V NEMA TT-30R RV Receptacle (30A)

Standard RV connector.

7. Grounding Nut

Ground generator to reduce risk of electric shock.

8. AC 120V NEMA L5-30R Receptacle (30A)

Multipurpose outlet.

9. AC 120V NEMA 5-20R Duplex Receptacles (20A)

Standard household outlets provide 120V 60Hz power.

10. DC 5V USB Ports

The upper and lower USB ports each provide 2.1A.

11. Overload Reset

If the overload light is ON, press this button to reset your generator.

12. Engine Switch

Start the engine using this switch.

13. Eco-Mode Switch

Flip this switch to ON to increase fuel economy and runtime when the load is below 2730W (75% load).

ASSEMBLY & ADJUSTMENTS

⚠ WARNING! Do not turn on the generator until it is fully assembled according to the instructions. Read through and become familiarized with the following procedures of handling and adjusting your tool. Failure to follow the safety instructions may result in serious personal injury.

- Never use the handle as a lifting point to support the entire weight of the generator. Only use the handle to pull the generator with the help of the wheels.
- Use caution when collapsing the handle. Hands and fingers could get caught and pinched.

ASSEMBLY

Refer to the packing list on p. 9 to gather the proper parts and tools for installing the feet, wheels, and handles.

NOTE: There are different sizes of bolts/nuts; be sure to use the proper bolts/nuts for each assembly step.

INSTALLING THE FOOT ASSEMBLY

The foot assembly is installed on the base of the generator, towards the rear, opposite the control panel.

1. Prepare a set of blocks on level ground (a 4×4 block of wood works well). Place the generator on the blocks. Have someone help you lift the generator.
2. Slide the foot assembly into place on the generator frame and align the holes.
3. Slide the M8×6 bolts through the foot assembly and generator frame. Tighten the bolts using the included wrench.

INSTALLING THE WHEELS

1. The wheels are installed on either side of the generator, towards the front, beside the control panel.
2. Align the wheels with the holes on the generator frame. Slide the axle pin through the wheel and the generator frame. Repeat for the other wheel.
3. Lock the wheels in place by fitting the R-clips through the holes in the axle pins.

INSTALLING THE HANDLES

1. The handles are installed on the rear of the generator, opposite the control panel.
2. Align the holes on the handle with the holes on the generator frame. Secure using an M8×40 bolt and an M8 nut. Repeat for the other handle.

GENERATOR PREPARATION

REMOVING THE SHIPPING POSTS

Your generator is shipped with three red shipping posts that secure the engine to the generator housing in order to prevent machine damage during shipping. Make sure to remove the three mounting posts before operating your generator. Failure to do so could lead to engine damage.

1. With the help of another person, place generator on an elevated platform such as table or workbench. Make sure the generator is stable. Do not tilt the generator as there may be remaining oil inside the crankcase from testing.
2. Use the included hex wrench to remove the three socket-head cap screws and red shipping posts (Fig. 1 - 1) from the generator's frame.
3. Follow the instructions in the following pages to prepare your generator for starting.

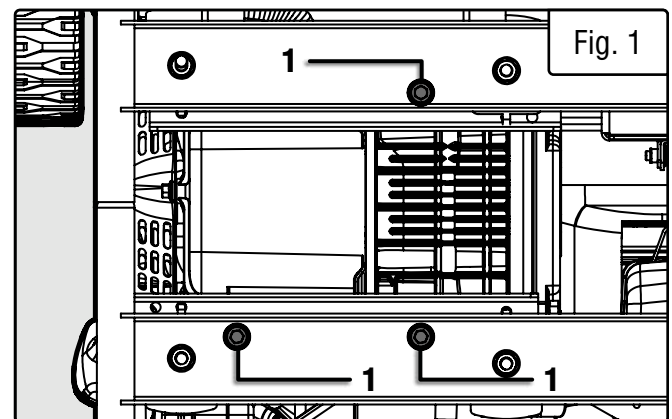

GENERATOR PREPARATION

The following section describes the necessary steps to prepare the generator for use. If you are unsure about how to perform any of the steps, please call **1-(800) 232-1195** M-F 8-5 CST for customer service. Failure to perform these steps properly can damage the generator or shorten its life.

STEP 1 - ADD / CHECK OIL

The generator is shipped without oil. User must add the proper amount of oil before operating the generator for the first time. The oil capacity of the engine crankcase is 20 fl. oz. (0.60 L).

ENGINE OIL RECOMMENDATIONS

Select good quality detergent oil bearing the American Petroleum Institute (API) service classifications SJ, SL, or SM (synthetic oils may be used). Select the SAE viscosity grade of oil that matches the expected operating temperature.

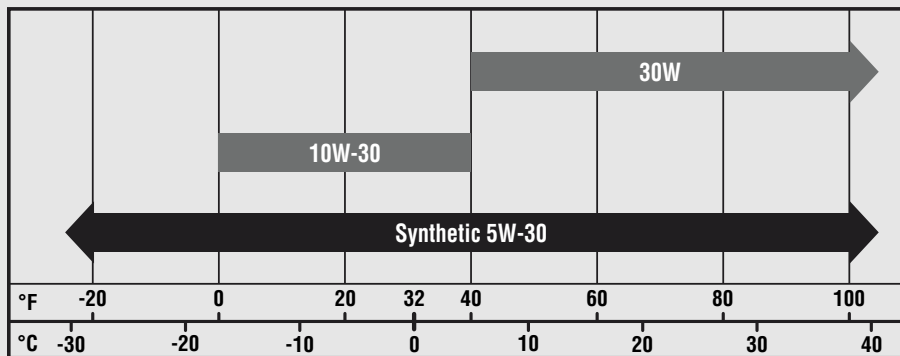

- **30W Engine Oil**
Temperatures above 40°F
- **10W-30 Engine Oil**
Temperatures between 0°F - 40°F
- **Synthetic 5W-30 Engine Oil**
All temperature ranges

To add oil, follow these steps:

1. Place the generator on a level surface. Make sure the engine is off before adding or checking oil.

CAUTION: Keep the generator level! Tilting the generator to assist in filling will cause oil to flow into the wrong areas of the engine and cause damage.

2. Turn the oil dipstick (Fig. 2 - 1) a quarter turn counter-clockwise, then remove the dipstick.

3. Using an oil funnel or appropriate dispenser, slowly add oil into the oil fill, being careful not to overfill the unit. Fill the crankcase until oil comes up the dipstick halfway between the L and H marks (see next page).

4. Reinstall the oil dipstick and firmly tighten it. Wipe clean any spilled oil.

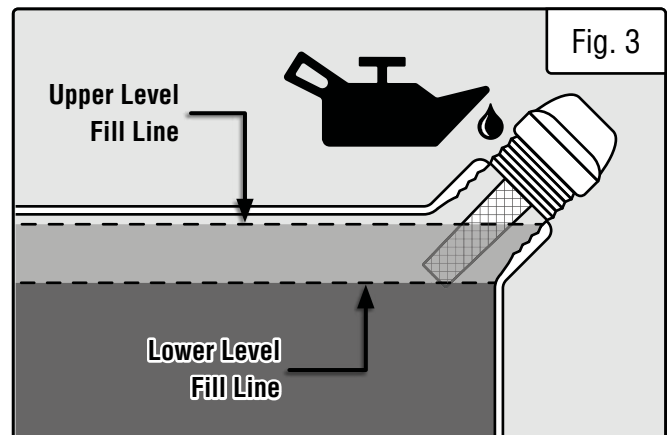
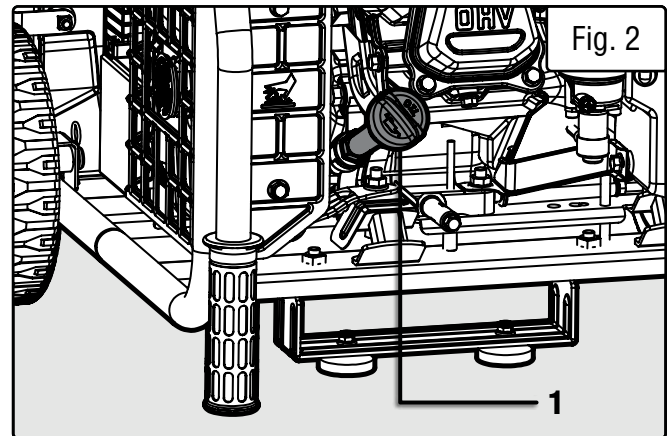

GENERATOR PREPARATION

STEP 1 - ADD / CHECK OIL (CONTINUED)

For subsequent operation, the oil level should be checked before each use, or after every 8 hours of operation. The generator is equipped with a low-oil sensor and will not start without a sufficient amount of oil.

To check oil level (before every subsequent start):

1. Place the generator on a level surface. Make sure the engine is off before adding or checking oil.
2. Remove and wipe the dipstick with a clean rag.
3. Insert the dipstick into the oil fill without screwing it in. Remove the dipstick to check the oil mark (Fig. 4).

If the oil mark covers less than one half of the dipstick, slowly add oil until the oil mark reaches to the top of the dipstick.

4. Wipe clean any oil leaks and firmly tighten the dipstick.

OIL LEVEL SHUTDOWN

To protect the unit from damage, the generator is equipped with a low-oil-pressure shutoff that will automatically stop the engine when the oil level is too low. The yellow low oil indication light (Fig. 5) will turn ON to remind you that the engine oil level is low and needs to be refilled.

The oil level of the engine should be checked before each start to ensure that the engine crankcase contains sufficient lubricant.

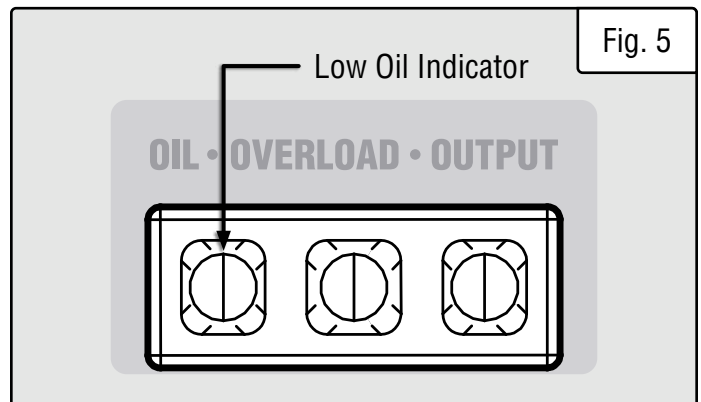
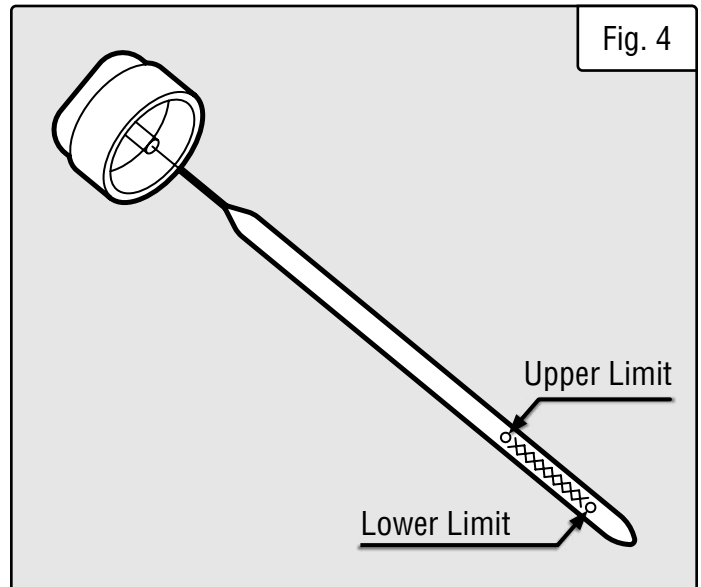

GENERATOR PREPARATION

STEP 2 - ADD / CHECK FUEL

FUEL OPTION A: GASOLINE

⚠ WARNING! RISK OF EXPLOSION. HIGHLY FLAMMABLE: This generator may emit highly flammable and explosive gasoline vapors, which can cause severe burns or even death, if ignited. A nearby open flame can lead to explosion even if not directly in contact with gasoline.

- Do not operate near open flame, heat, or any other ignition source. Do not smoke near the generator.
- Always operate on a firm, level surface.
- Always turn generator off before refueling. Allow generator to cool for at least 2 minutes before removing fuel cap. Loosen cap slowly to relieve pressure in tank.
- Do not overfill fuel tank. Gasoline may expand during operation. Do not fill to the top of the tank. Allow for expansion. Always check for spilled fuel before operating.
- If fuel spills, move the generator at least 30 feet away from the spill and wipe clean any spilled fuel before starting the engine.
- Empty fuel tank before storing or transporting the generator.

Use **ONLY** fresh (within 30 days from purchase), lead-free gasoline with a minimum of 87 octane rating. The generator performs best with ethanol-free gasoline. **DO NOT** use gasoline with over 10% ethanol. The capacity of the fuel tank is 4 US Gallons (15.20 L). Do not mix oil with gasoline.

To add gasoline:

1. Make sure the generator is shut OFF and on a level surface. Unscrew the fuel cap (Fig. 6 - 1) and set it aside. The fuel cap may be tight and hard to unscrew.

2. Slowly add unleaded gasoline to the fuel tank. Be careful not to overfill.

NOTE: Do not fill the fuel tank to the very top. If you do so, gasoline will expand and spill during use, even with the fuel cap in place.

3. Reinstall fuel cap and wipe clean any spilled gasoline with a dry cloth.

To check fuel level:

Check the fuel gauge on top of the fuel tank. If the fuel level is low, refill the fuel tank before starting your generator for the next time.

IMPORTANT:

- Avoid getting dirt or water into the fuel tank.
- Keep gasoline away from sparks, open flames, pilot lights, heat, and other sources of ignition.
- Gasoline can age in the tank and make starting difficult. Never store the generator for more than 2 months with fuel in the tank.
- Never use an oil/gasoline mixture.
- Never use old gasoline.

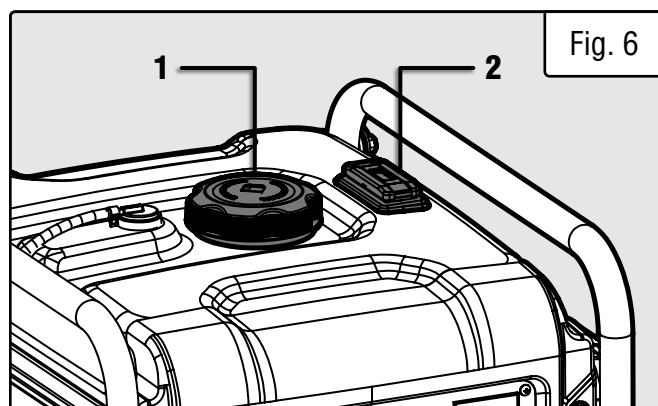

GENERATOR PREPARATION

STEP 2 - ADD / CHECK FUEL (CONTINUED)

FUEL OPTION B: LIQUID PETROLEUM GAS (LPG)

To connect your generator to an LPG cylinder:

1. Take off the safety caps from the cylinder valve, generator mounted regulator, and regulator connecting hose ends.

2. With the LPG tank valve closed, attach the LPG regulator connecting hose to the valve. Turn the plastic coupling from the hose right (clockwise) to tighten hose assembly onto the LPG tank (Fig. 7).

3. Remove the protective rubber cover from the LPG inlet (Fig. 8 - 1) on the generator panel. Connect the nut on the other end of the regulator connecting hose to the LPG inlet. Tighten the nut using the included 19mm wrench. Turn the 2-in-1 dial switch to OFF.

4. Turn the LPG tank valve ON (Fig. 9) and check for leaks by spraying soapy water to check connections. If bubbles appear, become larger in size, or increase in number, a leak exists. This **MUST** be corrected before using generator. Contact WEN customer service at **1-800-232-1195**, M-F 8-5 CST, or email techsupport@wenproducts.com for assistance.

NOTE: You can use Teflon (or other tape) to secure the connection of the LPG hose to your generator.

NOTE: If you would like to purchase other accessories for your dual-fuel generator, consult your local dealer of propane and propane accessories, I tell you what.

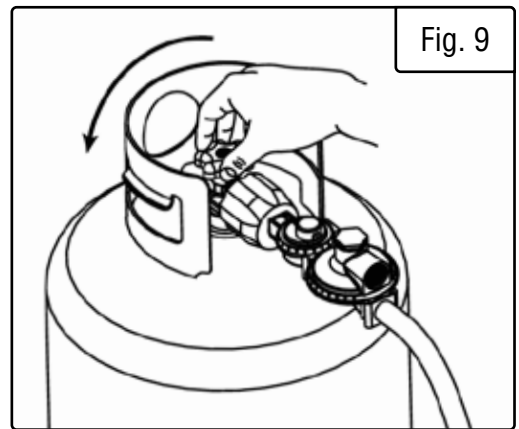
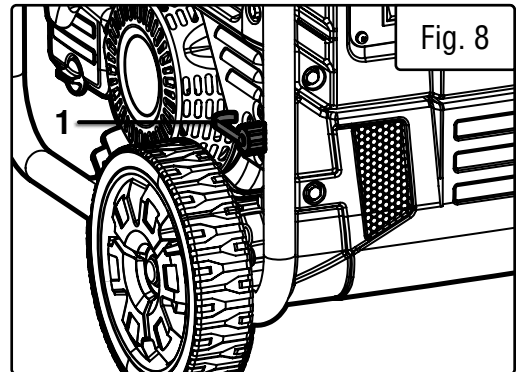
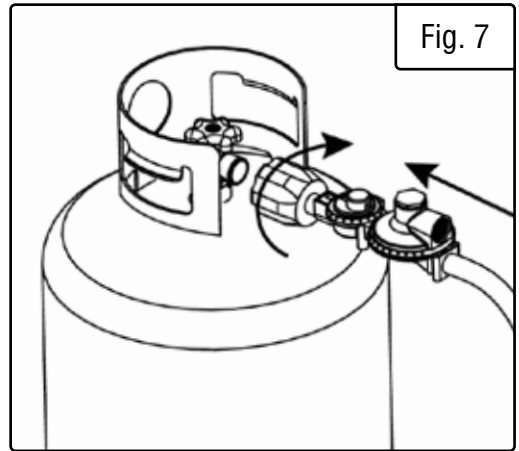

⚠ CAUTION! Always position the LPG cylinder so the connection between the tank and LPG inlet won't cause sharp bends or kinks in the hose.

⚠ WARNING! Risk of burns. Contact with liquid contents of cylinder will cause freeze burns to the skin. If liquid contents contacts skin or eyes, seek immediate medical attention.

⚠ WARNING! When transporting and storing, keep cylinder secured in an upright position with cylinder valve turned off. Keep cylinders ventilated and away from heat when in a vehicle.

GENERATOR PREPARATION

STEP 3 - CONNECT THE BATTERY

⚠ WARNING! Battery gives off explosive hydrogen gas.

- Keep the battery away from sparks, flames, and cigarettes.
- Do not connect or disconnect the battery while the generator is running.
- Service or use the battery only in well ventilated areas.

⚠ WARNING! Battery contains sulfuric acid. Battery acid is poisonous. Tilting the generator with the battery installed can cause battery acid to spill.

- Wear protective clothing and eye wear when servicing the battery.
- Keep out of the reach of children.
- Do not tilt the generator with the battery installed.
- If battery acid gets on your skin, wash with water immediately.
- If battery acid gets in your eyes, flush with water for at least 15 minutes and call a doctor immediately.

If battery acid is swallowed, call a doctor immediately. Drink a large amount of water or milk. Then drink the milk of magnesia or vegetable oil.

⚠ WARNING! Use only genuine WEN batteries with your generator (**part no. DG4500iX-074**). Use of other batteries may induce premature product failure and could pose a safety risk.

To connect the battery:

1. Connect the two ends of the quick connector on the battery (Fig. 10 - 1) to give power to the battery.

NOTE: The generator can be run with the battery disconnected or with no charge using the recoil starter. This can be done during either gasoline or LPG operation.

IMPORTANT: If you do not plan to use the generator for an extended period of time, we recommend **DISCONNECTING** the quick-connector. This will protect the battery from losing its charge. After disconnecting the quick-connector, cover the ends of the cable with an insulator such as electrical tape. Alternatively, you can use a trickle charger (not included) to maintain battery charge.

ABOUT THE BATTERY

1. **DO NOT INCINERATE BATTERY.** Do not throw the battery into an open fire as this poses a risk of explosion. Do not ignite the battery or expose it to fire.

2. **AVOID DAMAGE AND SHOCKS.** Immediately replace batteries that have been dropped from a height of more than one meter (3 feet) or those that have been exposed to violent shocks, even if the housing of the battery appears to be undamaged. The battery cells inside the battery may have suffered serious damage. In such instances, please read the waste disposal information for proper battery disposal.

3. **DO NOT CRUSH, DROP OR DAMAGE BATTERY.** Do not use the battery if it has sustained a sharp blow, been dropped, run over or has been damaged in any way (e.g. pierced with a nail, hit with a hammer, stepped on, etc.).

4. **DO NOT DISASSEMBLE.** Incorrect reassembly may pose a serious risk of electric shock, fire or exposure to toxic battery chemicals. If battery or charger are damaged, call WEN customer service at **1-800-232-1195** for assistance.

5. **DO NOT SHORT CIRCUIT.** Batteries will short circuit if a metal object makes a connection between the positive and negative contacts on the battery. Do not place the battery near anything that may cause a short circuit, such as paper clips, coins, keys, screws, nails and other metallic objects. A short-circuited battery poses a risk of fire and severe personal injury. **NOTE:** The safe temperature range for charging the battery is 25°F – 104°F.

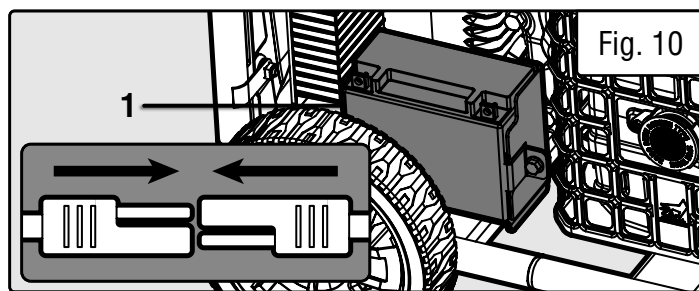

GENERATOR PREPARATION

STEP 4 - GROUND THE GENERATOR

To reduce the risk of electric shock and to maximize safety, the generator should be properly grounded.

Ground the generator by tightening the grounding nut (Fig. 11 - 1) on the front control panel against a grounding wire. A generally acceptable grounding wire is a No. 12 AWG (American Wire Gauge) stranded copper wire.

This grounding wire should be connected at the other end to a copper, brass, or steel grounding rod that is driven into the earth. Wire and grounding rods are not included with the generator.

NOTE: Grounding codes can vary by location. Contact a local electrician to check the area codes.

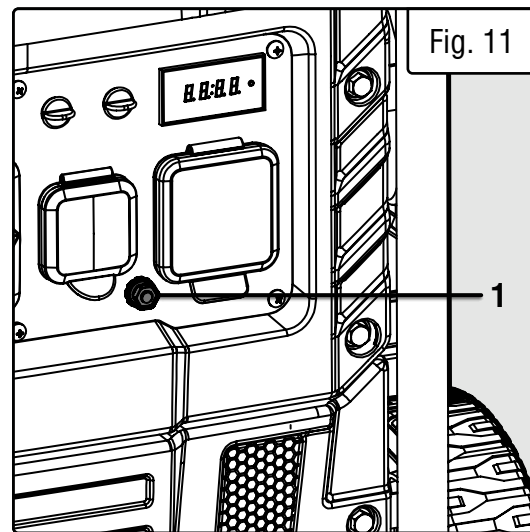

⚠ WARNING! Failure to properly ground the generator increases your risk of electric shock.

HIGH ALTITUDE OPERATION ABOVE 3000 FEET

The fuel system on this generator may be affected by operation at high altitudes. Proper operation can be ensured by installing an altitude kit at altitudes higher than 3000 feet above sea level. At elevations above 9800 feet, the engine may experience a decrease in performance, even with the proper altitude kit. Operating this generator without said kit may increase the engine's emissions and decrease both fuel economy and performance.

You can order the kit at wenproducts.com by searching part DG4500iX-HA. There are two kits - one for altitudes between 3000 and 6000 feet (**part no. DG4500iX-HA36**), and the other for altitudes from 6000 to 9800 feet (**part no. DG4500iX-HA69**). This kit should be installed by a qualified mechanic. Refer to the instructions included with your altitude kit for more information about installation.

NOTE: The high altitude kit must be installed for operation above 3000 feet, regardless of the fuel source (LPG or gasoline) used.

⚠ WARNING! To prevent serious injury from fire, follow the kit installation procedures in a well-ventilated area away from ignition sources. If the engine is hot from use, shut the engine off and wait for it to cool before proceeding. Do not smoke near the generator. Warranty will be void if adjustments are not made for high altitude use.

CAUTION: Engines with the high-altitude kit installed operated at lower altitudes could cause severe engine damage and affect emissions compliance. Be sure to uninstall the high altitude kit when operating at altitudes below 3000 feet.

After completing the above preparation, the generator is ready to be started.

STARTING YOUR GENERATOR

Before starting the generator, make sure you have read and performed the steps in the “Generator Preparation” section of this manual. If you are unsure about how to perform any of the steps in this manual please call **1-(800) 232-1195** M-F 8-5 CST for customer service.

DANGER! CARBON MONOXIDE

Using a generator indoors **CAN KILL YOU IN MINUTES**. Generator exhaust contains carbon monoxide (CO). This is a poison gas you cannot see or smell. If you can smell the generator exhaust, you are breathing CO. But even if you cannot smell the exhaust, you could be breathing CO.

NEVER use a generator inside homes, garages, crawl spaces, or other partially enclosed areas. Deadly levels of carbon monoxide can build up in these areas. Using a fan or opening windows and doors does NOT supply enough fresh air. **ONLY** use a generator outside and far away from windows, doors, and vents. These openings can pull in generator exhaust.

Even if you use a generator correctly, CO may leak into the home. **ALWAYS** use a battery-powered or battery-backup CO alarm in the home. If you start to feel sick, dizzy, or weak after the generator has been running, move to fresh air **RIGHT AWAY**. See a doctor. You may have carbon monoxide poisoning.

 **WARNING!** The exhaust from this product contains chemicals known to the State of California to cause cancer, birth defects, or other reproductive harm.

 **WARNING!** Do not operate generator near open flame or flammable materials. This generator may emit highly flammable and explosive gasoline vapors, which can cause severe burns or even death if ignited. A nearby open flame can lead to explosion even if it isn't directly in contact with gasoline. Do not smoke near the generator.

 **WARNING!** This generator produces powerful voltage, which can result in electrocution.

 **WARNING!** Do not use in rainy or wet conditions. Do not touch bare wires or receptacles (outlets). Do not allow children or non-qualified persons to operate.

 **WARNING!** Generator should only be connected to electrical devices, either directly or with an extension cord. **NEVER** connect to a building electrical system without a qualified electrician and connected to a transfer switch as a separately derived system. Such connections must comply with local electrical laws and codes. Failure to comply can create a back-feed, which may result in serious injury or death to utility workers.

To maximize safety, **ALWAYS** ground the generator before using it. See section “Ground the Generator”.

Use a ground fault circuit interrupter (GFCI) in highly conductive areas such as metal decking or steel work. GFCIs are available in-line with some extension cords.

CAUTION! Disconnect all electrical loads from the generator before attempting to start.

Follow the instructions on the next page to start your generator.

STARTING YOUR GENERATOR

BEFORE STARTING THE GENERATOR

1. Verify that generator is outside on a dry, level surface with at least two feet of clearance on all sides.
2. To maximize safety, check that the generator is properly grounded (see "GROUND THE GENERATOR").
3. Check there is sufficient level of oil in the crankcase. Add oil if necessary (see "ADD / CHECK OIL").
4. If using gasoline, make sure there is enough gasoline in fuel tank. Add fuel if necessary (see "ADD / CHECK FUEL"). If using LPG, make sure there is enough propane in tank, and that tank and regulator hose are properly connected.
5. Make sure all electrical devices are unplugged from the generator during ignition. Otherwise it will be difficult for the engine to start.

STARTING THE GENERATOR (GASOLINE)

1. Turn the ECO-MODE switch (Fig. 12) to "ON".
2. Turn the choke lever (Fig. 13 - 1) to the "CLOSED" position.
NOTE: If starting the generator with a warm engine, turn the choke lever to the "HALF-CHOKE" position.
3. Turn the FUEL SELECTOR knob (Fig. 14 - 1) to the "GAS ON" position.

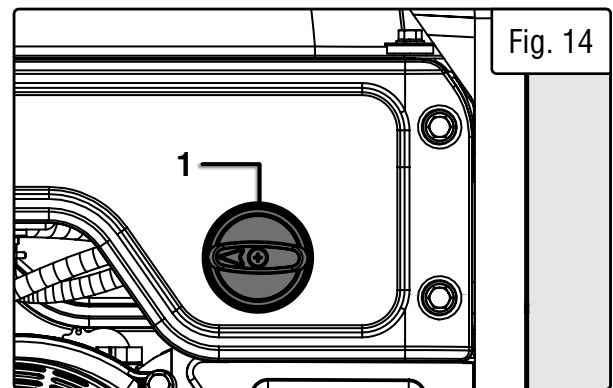
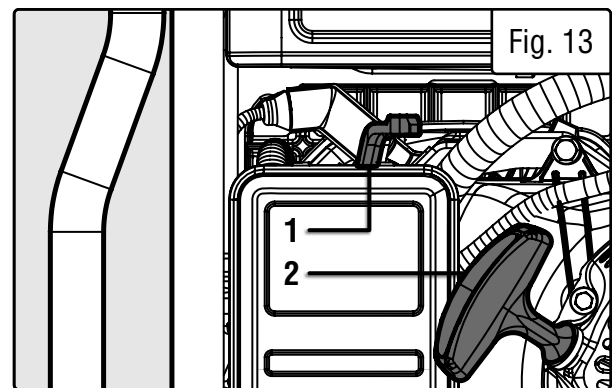
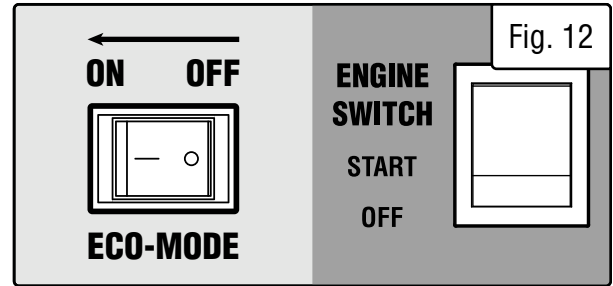

Option A: Electric Start

3. Push the ENGINE SWITCH (Fig. 12) to "START" and hold for 2-3 seconds, until the engine starts, then release.

NOTE: If the engine does not start, release the switch and try again. Keeping the switch in the "START" position too long can damage the starter.

NOTE: The battery is shipped partially charged, in order to maximize its service life, and may not have enough charge to start the engine during the first use of the generator. If you have trouble starting the generator the first time using electric start, use the pull start option and allow the generator to run for a few hours to charge the battery.

Option B: Pull Start

3. Place one hand on the generator to hold it in place, and pull on the recoil starter handle (Fig. 13 - 2) slowly until a slight resistance is felt. Then pull quickly to start the engine. Return cord gently into the machine. Never allow the cord to snap back.
4. If engine fails to start (with gas), repeat step 3; If engine fails to start (with LPG), turn the choke lever to "RUN", then pull on the recoil starter handle to get started.

4. When the engine starts, turn the choke lever (Fig. 13 - 1) to the "OPEN" position.
5. After the engine has started, the output indicator light (green) will light up.
6. Allow the generator to run for several minutes before attempting to connect any electrical devices. This allows the generator to stabilize its speed and temperature.

NOTE: If you have repeated failed attempts to start the engine, please consult the troubleshooting guide. If problems persist, please call please call **1-(800) 232-1195** M-F 8-5 CST.

STARTING YOUR GENERATOR

STARTING THE GENERATOR (LPG)

1. Turn the ECO-MODE (Fig. 15) switch to "ON".
2. Turn the choke lever (Fig. 16 - 1) to the "CLOSED" position.
3. Turn the FUEL SELECTOR knob (Fig. 17 - 1) to "LPG".
4. Prime the engine.

To do this, do one of the following:

- a. Manual Start: Pull the recoil starter 1 – 3 times.
 - b. Electric Start: Push the ENGINE SWITCH to the START position for about 2 seconds, 1 – 3 times.
5. Turn the choke lever (Fig. 13 - 1) to the "OPEN" position.

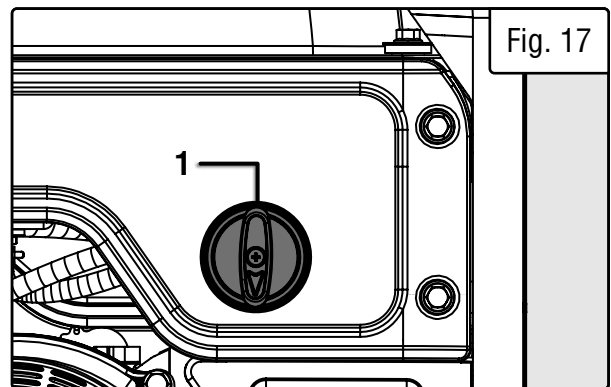
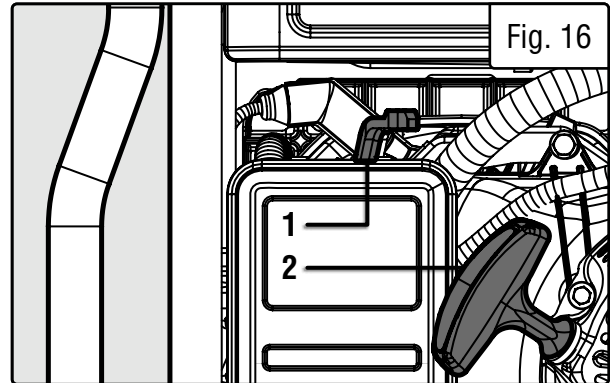
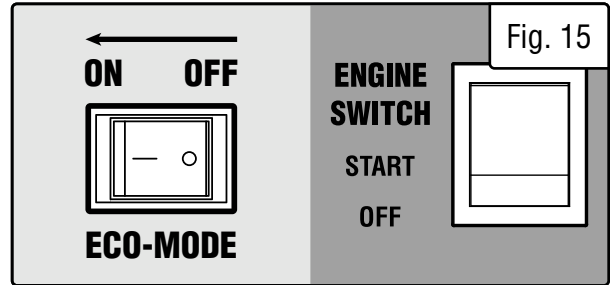

Option A: Electric Start

6. Push the ENGINE SWITCH to START and hold for 2-3 seconds, until the engine starts, then release the switch (Fig. 15).

NOTE: If the engine does not start, release the switch and try again. Keeping the switch in the START position too long can damage the starter.

NOTE: The battery is shipped partially charged, in order to maximize its service life, and may not have enough charge to start the engine during the first use of the generator. If you have trouble starting the generator the first time using electric start, use the pull start option and allow the generator to run for a few hours to charge the battery.

Option B: Pull Start

6. Place one hand on the generator to hold it in place, and pull on the recoil starter handle (Fig. 16 - 2) slowly until a slight resistance is felt. Pull quickly to start the engine. Return cord gently into the machine. Never allow the cord to snap back.

7. After the engine has started, the output indicator light (green) will light up.
8. Allow the generator to run for several minutes before attempting to connect any electrical devices. This allows the generator to stabilize its speed and temperature.

NOTE: If you have repeated failed attempts to start the engine, please consult the troubleshooting guide. If problems persist, please call please call **1-(800) 232-1195** M-F 8-5 CST.

ENGINE BREAK-IN PROCEDURE

The procedure below should be followed when you receive your generator in order to prolong the engine's service life. This procedure helps to seat the piston rings properly in the cylinder, and will reduce overall wear on the engine.

For the first 8 hours of operation, vary the load, but keep it at or below 50% of the generator's rated wattage, if possible. If your generator is equipped with an Eco-mode switch (only applicable for certain inverter generators), engage Eco-mode periodically during the first 8 hours. After the first 8 hours, change the oil, then change it again after the first 25 hours. You may run the generator at full load after the 8-hour oil change. Refer to the Recommended Maintenance Schedule in Table 4 for the full maintenance schedule.

USING YOUR GENERATOR

CALCULATING THE WATTAGE OF YOUR DEVICE(S)

Connect electrical devices running on AC current according to their wattage requirements. Calculate the total running wattage and starting wattage of the device(s) you wish to connect, and **MAKE SURE** that they are within the capacity of your generator and the capacity of each individual outlet.

| Generator Wattage Capacity | GENERATOR RUNNING (RATED) WATTS | GENERATOR STARTING (SURGE) WATTS |
|--|--|--|
| | Gasoline: 3650W | Gasoline: 4500W |
| | LPG: 3285W | LPG: 4500W |
| | <p>What this means: The generator can produce a maximum of 3650W / 3285W on a continuous basis to supply ongoing power to your electronic devices.</p> <p>NOTE: Also check the rated amperage for each outlet and make sure not to overload the individual outlets.</p> | <p>What this means: Some devices such as box fans require short bursts of extra power in addition to the rated wattage listed by the device to start their motors.</p> <p>The generator can produce a maximum wattage of 4500W for a short period of time (seconds) to cover the extra starting power required by your electronic devices.</p> |
| Electronic Device Wattage Calculation | <p>Find the wattage information of each device you plan to connect. The information should be listed on the device or in its instruction manual, or you may refer to page 23, Table 2.</p> <p>The wattage can be calculated using this equation: Watts = Volts x Amperes</p> | |
| | <p>To calculate the total running watts of your devices:</p> <p>+ Add up the running wattages of all the device(s) you plan to connect.</p> <p>= The total running (rated) wattage.</p> <p>This wattage should NOT exceed the running wattage of 3650W / 3285W.</p> <p>It is recommended to maintain a load at or below 3285 / 2950W (90% of the rated output) to ensure steady voltage output and to prolong the generator's lifespan.</p> | <p>To calculate the total starting watts of your devices:</p> <p>+ Add up the total running wattage of all the device(s) you plan to connect.</p> <p>+ Add the single highest ADDITIONAL starting wattage out of the device(s) you plan to connect.</p> <p>= The total starting (surge) wattage.</p> <p>This wattage should NOT exceed the starting wattage of 4500W.</p> |
| | <p>If any of either of the total calculated running watts or starting watts is higher than the capacity of your generator, adjust the load until both wattage requirements are met. Otherwise you will overload the generator, and cause damage to the engine and your electrical device(s).</p> | |

Table 1 - How to Calculate Wattages

USING YOUR GENERATOR

CALCULATING THE WATTAGE OF YOUR DEVICE(S) - CONTINUED

The chart below serves as a reference for the estimated wattage requirements of common electrical devices. However, do not solely rely on this chart - all electronics and appliances are built differently. Always check the wattage listed on the electrical device before consulting this chart.

| Tool or Appliance | Rated (Running) Watts | Surge (Starting) Watts |
|--------------------------------|------------------------------|-------------------------------|
| Electric Water Heater (40 Gal) | 4000 | 0 |
| Hot Plate | 2500 | 0 |
| Saw - Radial Arm | 2000 | 2000 |
| Electric Stove (Each Element) | 1500-2800 | 0 |
| Saw - Circular | 1500 | 1500 |
| Air Compressor (1 HP) | 1500 | 3000 |
| Window Air Conditioner | 1200 | 1800 |
| Saw - Miter | 1200 | 1200 |
| Microwave | 1000 | 0 |
| Well Water Pump | 1000 | 1000 |
| Sump Pump | 800 | 1200 |
| Refrigerator Freezer | 800 | 1200 |
| Furnace Blower | 800 | 1300 |
| Computer | 800 | 0 |
| Electric Drill | 600 | 900 |
| Television | 500 | 0 |
| Deep Freezer | 500 | 500 |
| Garage Door Opener | 480 | 0 |
| Stereo | 400 | 0 |
| Box Fan | 300 | 600 |
| Clock Radio | 300 | 0 |
| Security System | 180 | 0 |
| Dvd Player / VCR | 100 | 0 |
| Common Light Bulb | 75 | 0 |

Table 2 - Estimated Wattages of Common Electrical Appliances

NOTE: Become familiar with the functions and capacity of each component on the control panel before connecting electrical devices. See page 24 for more information about the components of the control panel. Do not overload generator or individual panel receptacles. Do not connect 50Hz or 3-phase loads to the generator.

USING YOUR GENERATOR

CONNECTING ELECTRICAL DEVICES

When the rated wattage requirement of each electrical device has been determined, add these numbers to find the total rated wattage needed. If this number exceeds the rated wattage (3650W / 3285W) of the generator, DO NOT connect all these devices. Select a combination of electrical devices with a total rated wattage lower than or equal to the rated wattage of the generator.

⚠ CAUTION! Become familiar with the markings on the control panel before connecting electrical devices. Do not connect 3-phase or 50Hz loads to the generator.

1. Before connecting electrical devices, allow the generator to run for a few minutes to stabilize the speed and voltage output.
2. Make sure that all devices are turned off. Start plugging in each electric device, from the highest wattage to the lowest. Check the power indicator light (green) to ensure the generator is producing power.
3. Do not overload the generator or individual panel receptacles. If an overload occurs, the overload indication light (red) will activate. If it is flashing, turn off and unplug one load. If it is solid (not flashing), the generator will cut off power to protect itself. Unplug all electrical devices and then press the reset button to reset the entire circuit, or press the circuit breaker to reset the DC circuit. Check the total wattage of the devices and reduce the load if it exceeds the capacity of the generator. Then, plug the loads back in one by one.

NOTE: If the reset button or circuit breaker does not reset, wait several minutes and try again. If problem still persists, please call **1-(800) 232-1195** M-F 8-5 CST, or email techsupport@wenproducts.com.

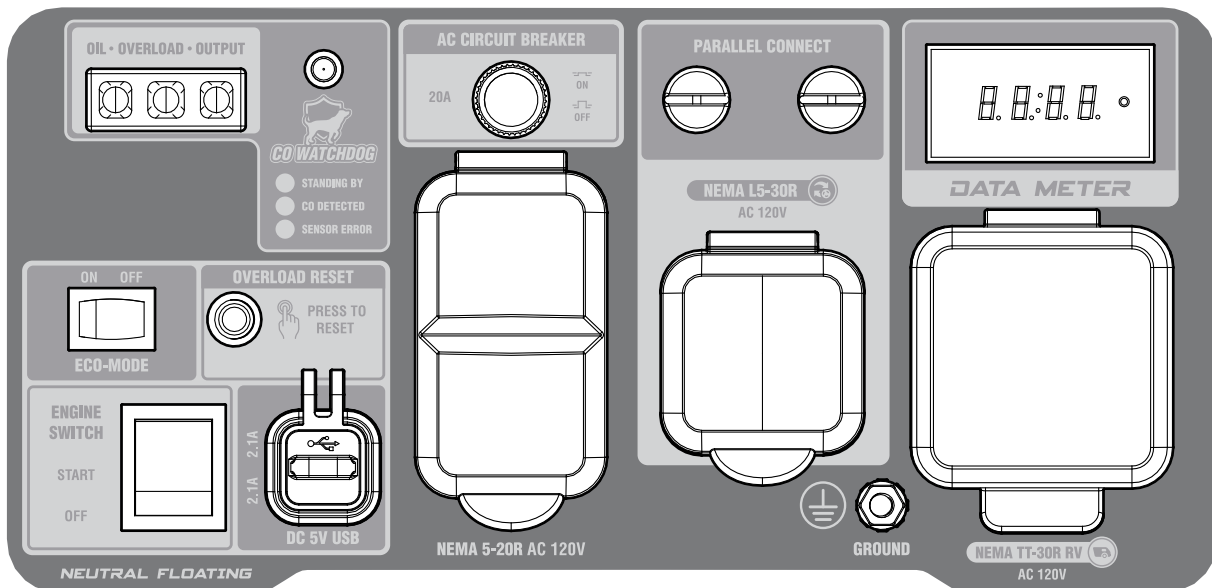

USING YOUR GENERATOR

SOME NOTES ABOUT POWER CORDS

Long or thin cords can drain the power provided to an electrical device by the generator. When using such cords, allow for a slightly higher rated wattage requirement by the electrical device.

| Device Requirements | | | Max. Cord Length (ft) by Wire Gauge | | | | |
|---------------------|--------------|--------------|-------------------------------------|----------|----------|----------|----------|
| Amps | Watts (120V) | Watts (240V) | #8 wire | #10 wire | #12 wire | #14 wire | #16 wire |
| 2.5 | 300 | 600 | NR | NR | NR | 375 | 250 |
| 5 | 600 | 1200 | NR | NR | 300 | 200 | 125 |
| 7.5 | 900 | 1800 | NR | 350 | 200 | 125 | 100 |
| 10 | 1200 | 2400 | NR | 250 | 150 | 100 | 50 |
| 15 | 1800 | 3600 | NR | 150 | 100 | 65 | NR |
| 20 | 2400 | 4800 | 175 | 125 | 75 | 50 | NR |
| 25 | 3000 | 6000 | 150 | 100 | 60 | NR | NR |
| 30 | 3600 | 7200 | 125 | 65 | NR | NR | NR |
| 40 | 4800 | 9600 | 90 | NR | NR | NR | NR |

*NR = Not Recommended

Table 3 - Power Cord Requirement Guide

⚠ WARNING! Generator should **only** be connected to electrical devices, either directly or with an extension cord. NEVER CONNECT TO A BUILDING ELECTRICAL SYSTEM without a qualified electrician and connected to a transfer switch as a separately derived system. Such connections must comply with local electrical laws and codes. Failure to comply can create a back-feed, which may result in serious injury or death to utility workers.

NOTE: For power outages, permanently installed, stationary generators are better suited for providing backup power to your home. Even a properly connected portable generator can become overloaded. This may result in overheating or stressing the machine's components, possibly leading to generator failure.

SWITCHING FUELS

To switch fuels, turn the fuel selector knob to "GAS ON" or "LPG". To maximize your generator's lifespan, we recommend removing all loads from the generator before switching between gasoline and LPG. If this is not possible, reduce loads as much as possible in order to ensure a smooth switch. Your generator is rated to handle a higher load when running on gasoline than on LPG, so keep this in mind when planning your fuel usage.

USING YOUR GENERATOR

ECO-MODE SWITCH

This generator is equipped with an Eco-Mode Idle Control Switch (Fig. 18). Engaging this switch allows the system to regulate the engine speed and automatically adjust its fuel consumption to match the required load. When the electrical load changes, the generator engine will automatically speed up and slow down as needed. This reduces fuel consumption and noise levels, while extending runtime and engine's lifespan.

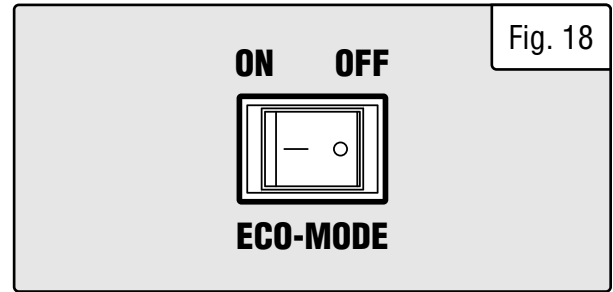

Keep this switch engaged **ONLY** when the power load requirement is less than 2730W. Do not engage the Eco-Mode Switch when the total load is more than 2730W. The generator engine must run at full speed to supply power for anything over 2730W.

PARALLEL OPERATION

The parallel connection ports (Fig. 19) allow you to connect two WEN generators to increase the total available electrical power. The WEN Parallel Connection Kit can be purchased from wenproducts.com. Follow the instructions included with your parallel connection kit for proper installation and operation.

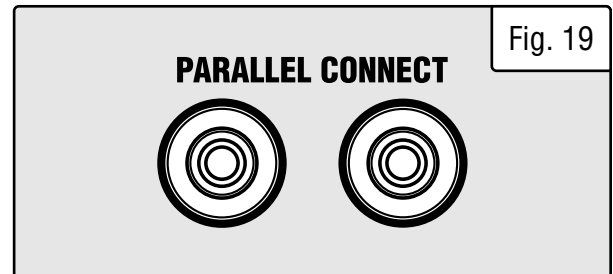

IN CASE OF OVERLOAD

If your generator becomes overloaded from too much drawn wattage, the overload indicator (red) on the control panel will light up. Follow the instructions below when an overload occurs:

- When you're close to overloading the generator, the overload light will start to flash. Reduce the load by turning off and disconnecting your electronic device(s) until the overload light turns off. Then you may continue to operate your generator.
- When you've overloaded the generator, the overload light will stay on and the reset button (Fig. 20) will activate to cut off the output in 3 to 16 seconds, depending on the load. Reduce the load by turning off and disconnecting your electrical device(s) until the overload light turns off. Wait about five minutes and then press the activated reset button to reset the circuit. If no power is produced after resetting, turn off and disconnect all electrical devices and restart your generator.

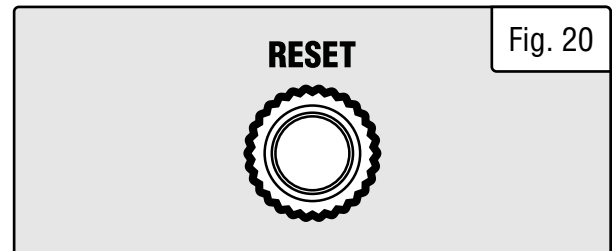

| LIGHT | | MEANING | RESOLUTION |
|-------------------------|---|--|--|
| GREEN (POWER INDICATOR) | RED (OVERLOAD) | | |
| ON | OFF | Generator output is normal. | No action needed. |
| ON | Flashing Continuously | Generator is exceeding rated output. | Reduce load on generator. |
| OFF | Flashes 1x Repeating every 3 seconds | Voltage at alternator is too low. No electrical output. | Check for loose connections. Call 1-800-232-1195 for assistance. |
| OFF | Flashes 2x Repeating every 3 seconds | Engine speed is too low. No electrical output. | Check carburetor and stepper motor. Ensure Eco-Mode is OFF. Have generator serviced; call 1-800-232-1195 for assistance. |
| OFF | Flashes 3x Repeating every 3 seconds | Inverter temperature is too high. No electrical output. | Turn generator off and let cool down fully (1-2 hours) before restarting. |
| OFF | Flashes 5x Repeating every 3 seconds | Voltage at alternator is too high. No electrical output. | Have generator serviced; call 1-800-232-1195 for assistance. |
| OFF | Flashes 6x Repeating every 3 seconds | Generator has exceeded rated output and cut off power to protect itself. No electrical output. | Turn OFF and disconnect loads. Press RESET button on panel. Reduce load on generator. |

USING YOUR GENERATOR

CIRCUIT BREAKERS

In addition to the reset button that protects the generator's main circuit, the circuit breaker (Fig. 21) protects the NEMA 5-20 outlets. The 20-amp AC circuit breaker will activate when the NEMA 5-20 outlets exceed 20A. When the circuit breaker activates, turn off and disconnect the device from its respective outlet, and press the circuit breaker to reset.

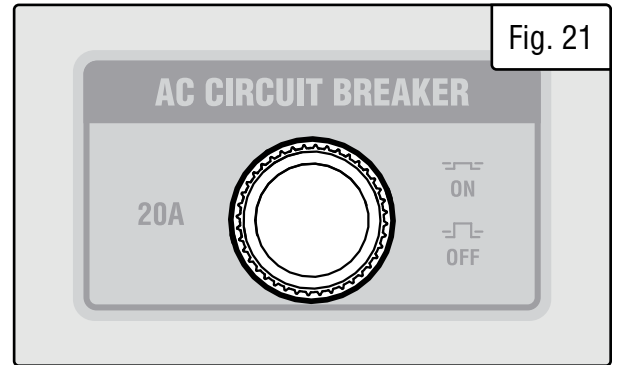

USING YOUR GENERATOR

CO SENSOR INFORMATION

The CO Watchdog carbon monoxide monitoring system (Fig. 22 - 1) measures the accumulation of poisonous CO gas while the generator is running. If the level of CO gas gets too high, the CO Watchdog system will automatically shut down the generator. **This system is not a substitute for an indoor CO alarm.**

Whenever the CO Watchdog system shuts down the generator, the LED on the generator control panel (Fig. 22 - 1) will **blink red** for at least 5 minutes after the generator is shut down. **If you notice that the LED is blinking red, vacate the area immediately.** Go to an open, outdoor area. Ventilate the area around the generator thoroughly before returning. Let the generator stay shut down for a few minutes before restarting the engine. This should allow carbon monoxide to dissipate from the area. If you restart the generator and the CO Watchdog detects that CO levels are still too high, it will shut down the generator again. If CO levels are low enough, the generator will run normally.

Ensure that the generator is located in an open outdoor area, with the exhaust pointing away from occupied structures, and pointing away from the prevailing winds, such that those winds do not blow engine exhaust towards the sensor module. If anyone experiences dizziness, headaches, nausea, fatigue, or other symptoms of CO poisoning, get to fresh air immediately and seek the attention of a qualified medical professional. Follow all other directions in this manual regarding the connection and disconnection of electrical devices when starting or shutting down the generator.

When starting the generator, the CO Watchdog LED on the panel may flash. This indicates that the system is running a self-test procedure, and does not indicate a problem.

If the CO Watchdog LED on the panel is **yellow**, a system error has occurred, or the CO sensor has reached the end of its life. Contact WEN customer service (**1-800-232-1195**, M – F 8 – 5 CST, or **techsupport@wenproducts.com**) for assistance.

When operating your generator, please note the following:

- The CO Watchdog does not discriminate in its input; any source of carbon monoxide in the area around the generator could cause it to activate. If the CO Watchdog LED is blinking red, safety measures should be taken immediately.
- Tampering with, disconnecting, or bypassing the CO sensor could cause hazardous conditions, including but not necessarily limited to injury or death, and will void your warranty. The generator will not run with the CO sensor disconnected or bypassed, or if the CO sensor indicates an error.
- The CO sensor has a lifetime of about 7 years, and is capable of monitoring its lifetime. If your generator shows an error light several years after purchase, it may be time to replace the CO sensor. Contact WEN customer service for assistance.

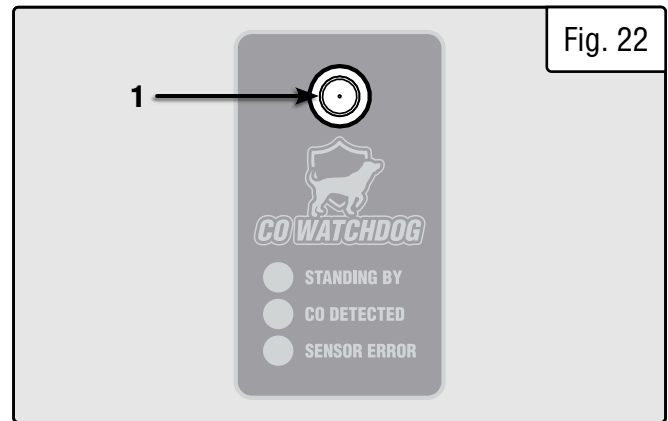

NOTE: if the generator is oriented so that the engine exhaust is blown towards the CO sensor, the generator may shut down.

SHUTTING OFF YOUR GENERATOR

⚠ CAUTION! Unplugging running devices can cause damage to the generator. Never stop the engine with electrical devices connected and running.

OPTION 1A: AUTOMATIC FUEL SHUTOFF (RECOMMENDED – GASOLINE ONLY)

Your generator is equipped with automatic fuel shutoff. This feature turns off the flow of fuel, allowing for the generator to use up the remaining fuel from the carburetor before turning off. This prolongs the lifespan of the generator by preventing build-up and blockages caused by stagnant fuel inside of a carburetor.

1. Turn off all electrical devices prior to unplugging them from the generator. Unplugging running devices can cause damage to the generator.

2. Allow generator to run at no load for a few minutes to stabilize internal temperatures.

3. Turn the propane tank valve to the OFF position (if the propane regulator hose is connected to the generator).

4. Turn the FUEL SELECTOR knob to the "GAS OFF" position (Fig. 23 - 1).

5. The engine will continue to run until the majority of the fuel in the carburetor is consumed, which takes a few minutes. It will then shut off automatically. This feature helps to prevent the carburetor from being clogged by stale fuel, extending your generator's lifespan.

6. Turn the FUEL SELECTOR knob to the "ENGINE OFF" position.

OPTION 1B: AUTOMATIC FUEL SHUTOFF (RECOMMENDED – LPG ONLY)

Although LPG is not prone to degradation the way gasoline is, it is still a good idea to turn the LPG tank OFF before disconnecting the regulator hose from the generator, so that LPG does not leak from the hose.

1. Turn off all electrical devices prior to unplugging them. Unplugging running devices can cause damage to generator.

2. Allow generator to run at no load for a few minutes to stabilize internal temperatures.

3. Turn the FUEL SELECTOR knob (Fig. 23 - 1) to the "GAS OFF" position. The engine will continue to run until propane in the carburetor is consumed, which will be nearly immediately. It will then shut down automatically.

4. Turn propane tank valve to OFF position.

NOTE: If there is gasoline in the fuel tank, and any gasoline has made it into the carburetor for some reason, the generator may continue to run for a few minutes until the gasoline has been consumed.

5. Turn the FUEL SELECTOR knob to the "ENGINE OFF" position.

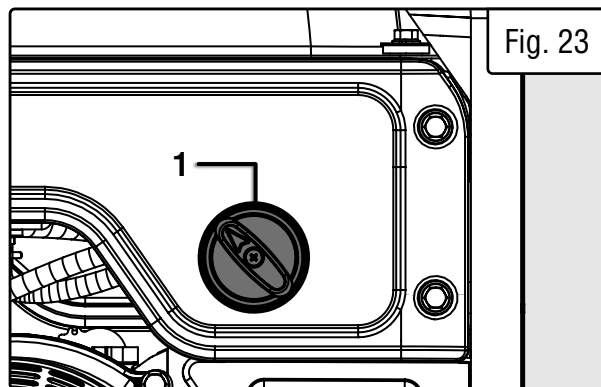

SHUTTING OFF YOUR GENERATOR

CAUTION! Unplugging running devices can cause damage to the generator. Never stop the engine with electrical devices connected and running.

OPTION 2: MANUAL SHUTOFF

In case you are in a hurry and do not want to wait for the generator to automatically shut down, the manual shutoff feature is available. However, this method will leave stagnant fuel in the carburetor, possibly causing blockages, a shortened lifespan, and other maintenance issues. If this approach is frequently taken, make sure to drain your carburetor before any long storage periods.

1. Turn off all electrical devices prior to unplugging them from the generator. Unplugging running devices can cause damage to the generator.
2. Turn the FUEL SELECTOR knob to the "ENGINE OFF" position (Fig. 24).

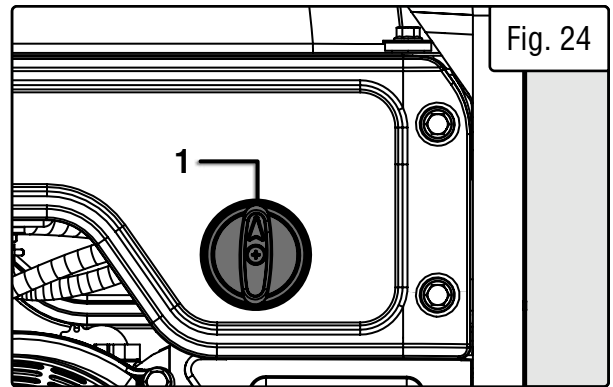

WARNING! Allow the generator to cool down before touching areas that become hot during use.

CAUTION: Allowing gasoline to sit in the fuel tank for long periods of time can make it difficult to start the generator in the future. Never store the generator for extended periods of time (over 2 months) with fuel in the fuel tank. Refer to "Storing the Generator."

MAINTENANCE

Proper routine maintenance of the generator will help prolong the life of the machine. Please perform maintenance checks and operations according to the schedule in Table 4.

⚠ CAUTION! Never perform maintenance operations while the generator is running. Before maintaining or servicing the generator, turn OFF the generator, disconnect all devices and allow the generator to cool down.

If there are any questions about the maintenance procedures listed in this manual, please call **1-(800) 232-1195** M-F 8-5 CST or email techsupport@wenproducts.com.

| Recommended Maintenance Schedule | | Every 8 Hours or Daily | Every 25 Hours | Every 3 Months or 50 Hours | Every 6 Months or 100 Hours | Before Storage | As Necessary |
|----------------------------------|-------------------|------------------------|----------------|----------------------------|-----------------------------|----------------|--------------|
| Engine Oil | Check Level | x | | | | | |
| | Replace | x** | x** | x* | | | x |
| Air Filter | Check | | | x* | | | |
| | Clean | | | x* | | | |
| Spark Plug | Check/Clean/Regap | | | | x | | |
| | Change | | | | x | | x |
| Fuel | Check Level | x | | | | | |
| | Drain | | | | | x | x |
| Carburetor | Drain | x | | | | | x |
| Spark Arrestor | Check/Clean | | | | x | | |

* Clean/change more often under dusty conditions or operating under heavy load. Table 4 - Recommended Maintenance Schedule

** Change the oil after the first 8 hours of operation, after the first 25 hours of operation, and every 50 hours after that.

IMPORTANT GENERATOR MAINTENANCE TIPS:

- Drain your carburetor after each use and before storage to prevent it from clogging.
- Do not store the generator with fuel inside the tank for more than 2 months - the fuel will go bad.
- Run the generator for at least 20 minutes every month to charge the battery and maximize lifespan.

CLEANING THE GENERATOR

Keep the generator clean to prevent improper operation or machine damage from dirt and debris. Inspect all ventilation openings on the generator. These openings must be kept clean and unobstructed. If the generator becomes dirty, use a damp cloth to wipe exterior surfaces. Use a soft bristle brush to loosen dirt and oil and use a vacuum to pick up loose dirt. Use low pressure air (not to exceed 25 PSI) to blow away dirt.

⚠ CAUTION! Never clean the generator when it is running! Never clean with a bucket of water or a hose. Water can get inside the working parts of the generator and cause corrosion or a short circuit.

NOTE: Failure to properly maintain the generator will void the warranty.

MAINTENANCE

CLEANING THE GENERATOR

Keep the generator clean to prevent improper operation or machine damage from dirt and debris. Inspect all ventilation openings on the generator. These openings must be kept clean and unobstructed.

If the generator becomes dirty, use a damp cloth to wipe exterior surfaces. Use a soft bristle brush to loosen dirt and oil and use a vacuum to pick up loose dirt. Use low pressure air (not to exceed 25 PSI) to blow away dirt.

⚠ WARNING! Never clean the generator when it is running! Never clean with a bucket of water or a hose. Water can get inside the working parts of the generator and cause corrosion or a short circuit.

CHECKING / ADDING OIL

Check the oil level before each use and every 8 hours of operation (refer to Table 4).

The oil capacity of the generator engine is 18.6 fl. ounces. Add oil when the oil level is low. For proper type and weight of oil refer to “add oil” portion of the “Generator Preparation” section. This is a critical step for proper engine starting. The generator is equipped with a with low-oil shut down to protect it from running without oil.

To check the oil level and add oil:

1. Make sure the generator is on a level surface. Do not tilt the generator, as oil will flow into engine areas and cause damage. Keep generator level!
2. Remove the dipstick and wipe it with a clean rag.
3. Insert the dipstick into the oil fill opening without screwing in. Remove the dipstick to check the oil mark (Fig. 25). Add oil if the oil mark covers less than one half of the dipstick.
4. Using a funnel or appropriate dispenser, slowly add more oil. Repeat the step above until the oil mark reaches the top of the dipstick. Do not over fill.
5. Reinstall dipstick and wipe clean any spilled oil with a rag.

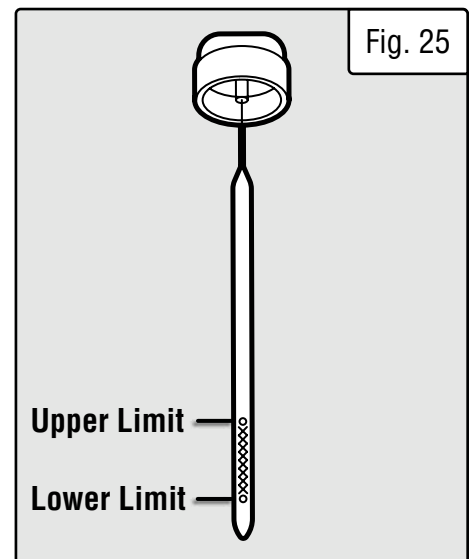

DRAINING THE CARBURETOR

We recommend draining the carburetor after every use and before storing the generator. (If the generator is shut off using the GAS OFF feature, it is only necessary to drain it before periods of long storage.) Draining the carburetor can prevent the fuel from clogging up the carburetor; a clogged carburetor can prevent the generator from starting.

1. With the help of another person, place the generator on an elevated platform such as a table or desk.

2. Make sure that the FUEL SELECTOR knob is turned to "ENGINE OFF". At this position, the fuel valve is turned OFF so that only the fuel left inside the carburetor will be drained out.

3. The carburetor (Fig. 26 - 1) can be accessed on the back of the generator, right beside the air filter.

4. Prepare an approved gasoline-storage container and a funnel.

5. Open up the carburetor drain screw (Fig. 26 - 2) with a Phillips-head screwdriver and drain out any gasoline that has built up inside the carburetor through the funnel into the approved gasoline-storage container.

6. Once the fuel has drained, tighten the drain screw with the screwdriver.

NOTE: Make sure to drain your carburetor before storing the generator for long periods of time.

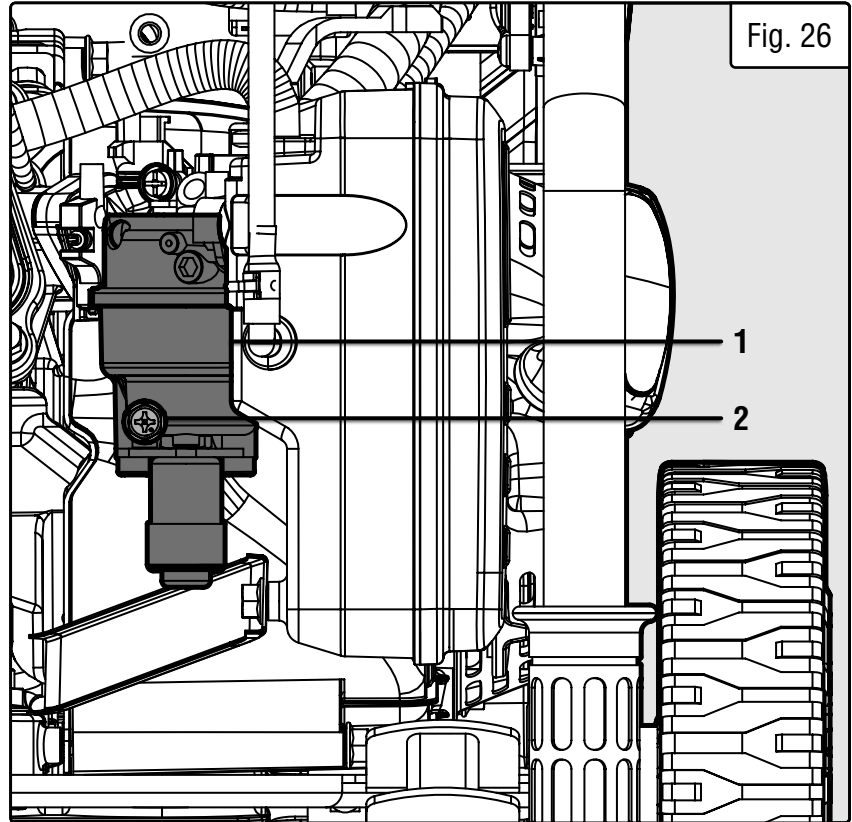

AIR FILTER MAINTENANCE

Check every 50 hours of operation (refer to Table 4 - Recommended Maintenance Schedule).

Routine maintenance of the air filter helps maintain proper airflow to the carburetor. Occasionally check that the air cleaner is free of excessive dirt.

To inspect and clean the air filter:

1. Remove the air filter cover (Fig. 27 - 1) by unscrewing the cover lock knob (Fig. 27 - 2) at the bottom of the air filter cover.

2. Remove the foam, sponge-like air filter element from the casing. Wipe excessive oil and any dirt from inside of the air filter casing.

3. Check the foam, sponge-like air filter element.

a) **Good elements** can be washed in soapy water. Dry the element in clean cloth (do not twist it). Add a few drops of engine oil to the air filter element and spread it evenly. A small amount of oil left in the element is normal and necessary for the engine to work properly.

b) **Damaged elements** should be replaced with a new one. Replacement air filters can be purchased from wenproducts.com by searching **part number 56500-134**.

4. Reinstall the air filter element and air filter cover.

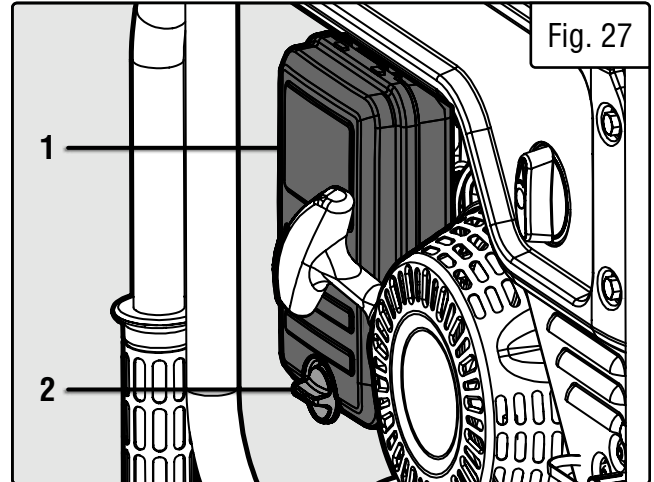

⚠ WARNING! Running the engine with a dirty, damaged or missing air filter element can result in danger to the operator and cause the engine to wear out prematurely.

SPARK ARRESTOR MAINTENANCE

Inspect and clean the spark arrestor every 100 hours of operation. The spark arrestor is located outside the muffler, which gets very hot during operation. Allow the engine to cool completely before servicing the spark arrestor. To inspect and clean the spark arrestor:

1. Remove the two Phillips-head screws that secure the spark arrestor to the muffler (Fig. 28 - 1).

2. Remove the spark arrestor screen.

3. Carefully clean and remove the carbon deposits from the spark arrestor screen with a wire brush. Replace the spark arrestor if it is damaged (replacement spark arrestors can be purchased from wenproducts.com by searching the **part no. DG4500iX-086**).

4. Reinstall the spark arrestor in the muffler and secure it in place with the screws.

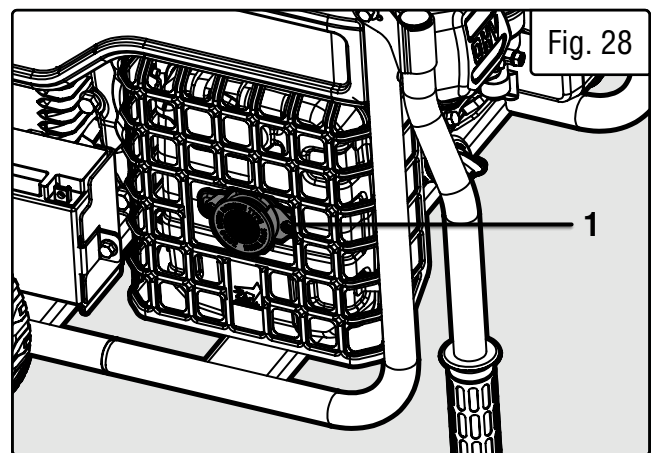

SPARK PLUG MAINTENANCE

Refer to Recommended Maintenance Schedule in Table 4 for maintaining the spark plug. The spark plug is important for proper engine operation. Check the spark plug regularly to maintain proper engine operation. A good spark plug should be intact, free of deposits, and properly gapped.

To inspect or replace the spark plug:

1. Gently pull on the spark plug boot (Fig. 29 - 1) to remove it. Be careful not to tear any insulation or wire.

2. Use the included spark plug socket (Fig. 30) to unscrew and then carefully remove the spark plug from the engine.

TIP: There is limited space for the wrench to turn. Use both rows of holes in the spark plug wrench to gain leverage to loosen the plug.

3. Visually inspect the spark plug. If it is cracked or chipped, or if the electrodes are worn or burned, discard it and replace with a new spark plug.

We recommend replacing with a F6RTC spark plug (**part no. 56310i-0104**), available for purchase at wenproducts.com.

4. If re-using the spark plug, use a wire brush to clean any dirt from around the spark plug base, then re-gap the spark plug.

5. Measure the plug gap with a spark plug gap gauge. The gap should be 0.6 - 0.8 mm (0.024 - 0.031 in) (Fig. 31). Carefully adjust the gap if necessary.

6. Screw the spark plug back into the spark plug hole using the spark plug wrench. Do not over-tighten spark plug. Recommended tightening of spark plug is $\frac{1}{2}$ to $\frac{3}{4}$ of a turn (15 ft-lb torque/20.33 Nm) after spark plug gasket contacts spark plug hole.

7. Reinstall the spark plug boot, spark plug rubber cover, and service panel.

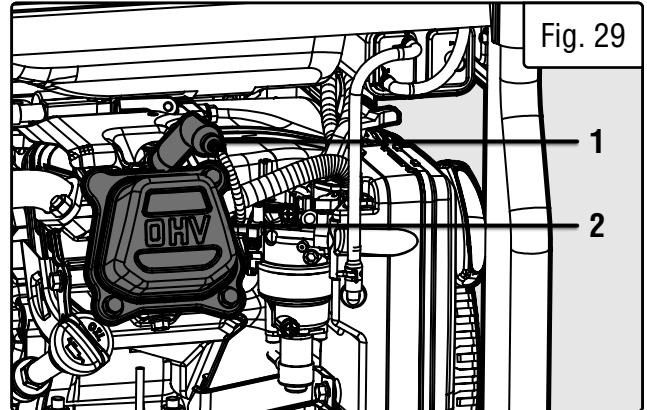

Fig. 29

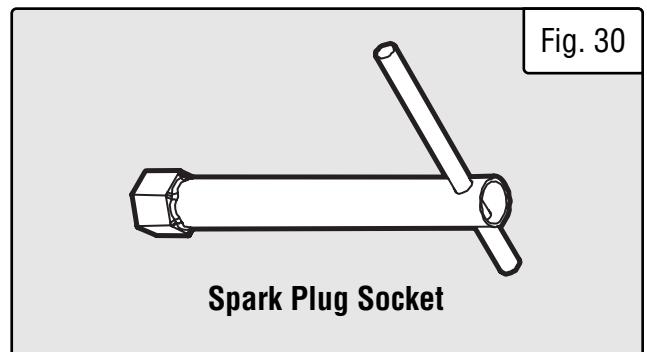

Fig. 30

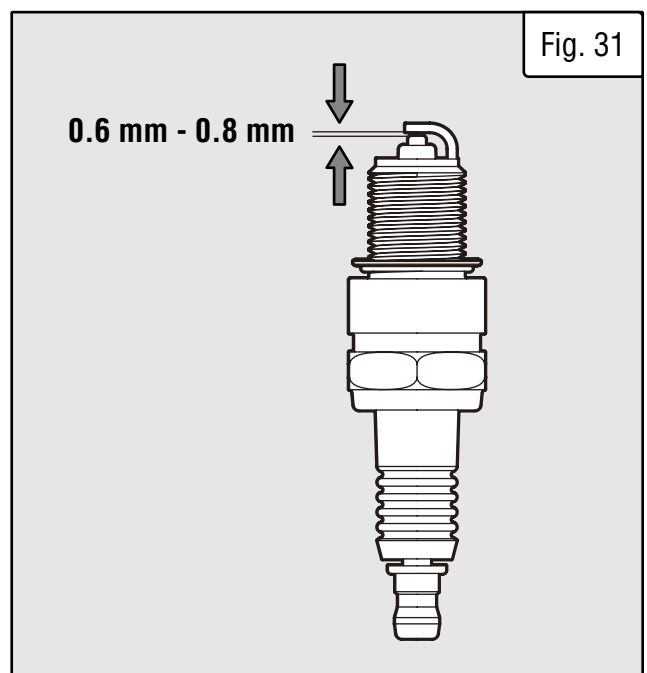

Fig. 31

MAINTENANCE

DRAINING / CHANGING OIL

Change the oil according to the Recommended Maintenance Schedule in Table 4. Change the oil MORE OFTEN if operating under heavy load or high ambient temperatures. It is also necessary to drain the oil from the crankcase if it has become contaminated with water or dirt. Changing the oil when the engine is warm allows for more-complete drainage.

To change engine oil:

1. With the help of another person, place the generator on an elevated platform such as table or workbench.

NOTE: To avoid possible gasoline spills from the carburetor bowl, drain the carburetor before draining oil.

2. Prepare an approved oil-storage container and place it below the oil drainage bolt (Fig. 32 - 1) to catch oil as it drains.

4. Use a 10mm socket to loosen and remove the oil drainage bolt, and allow oil to drain from the engine completely.

5. Replace and tighten the oil drainage bolt after the oil has drained.

NOTE: Never dispose of used engine oil in the trash or down a drain. Please call a local recycling center or auto garage to arrange proper oil disposal.

6. Unscrew the oil dipstick. Using a funnel or appropriate dispenser, add 20 fl. oz. (0.60 L) of clean engine oil into the oil fill. Check the oil level periodically using the dipstick. Do not over fill.

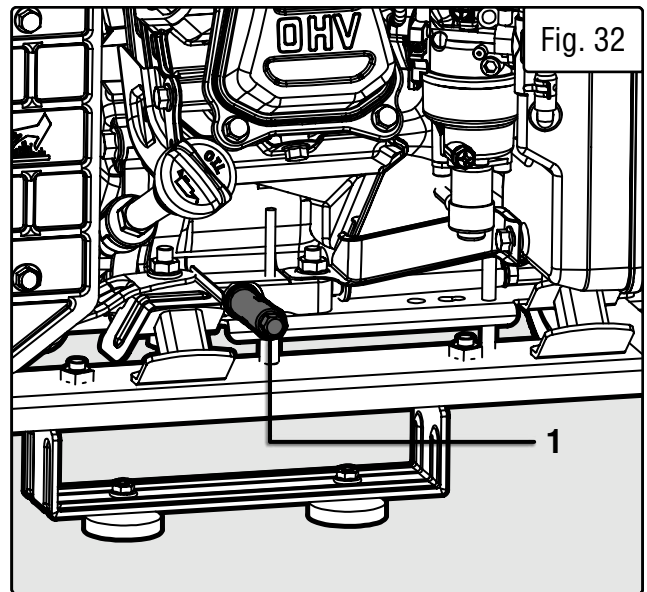

DRAINING THE FUEL TANK

Drain and clean the fuel tank each year, or before storing the generator for longer than two months.

To drain the fuel tank and carburetor:

1. Locate the carburetor (Fig. 33 - 1). It can be accessed on the back of the generator, right beside the air filter.

2. Prepare an approved gasoline-storage container and a funnel.

3. Remove the fuel cap (Fig. 34 - 1). Turn the FUEL SELECTOR knob (Fig. 34 - 2) to "GAS ON".

4. Open up the carburetor drain screw (Fig. 33 - 2) with a Phillips screwdriver. Fuel will start draining from the carburetor and fuel tank through the funnel.

NOTE: The draining process may take a few hours, depending on the amount of fuel in your gas tank.

5. Once fuel is completely drained from the tube, reinstall the fuel cap and turn the FUEL SELECTOR knob to "ENGINE OFF". Tighten the drain screw with the screwdriver.

6. Start and run the generator until the fuel runs out.

7. Store the emptied gasoline in a suitable place. **DO NOT** store flammable materials near the gasoline.

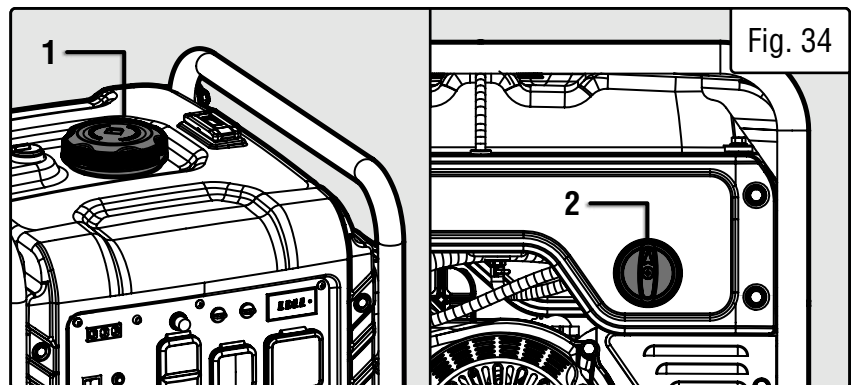
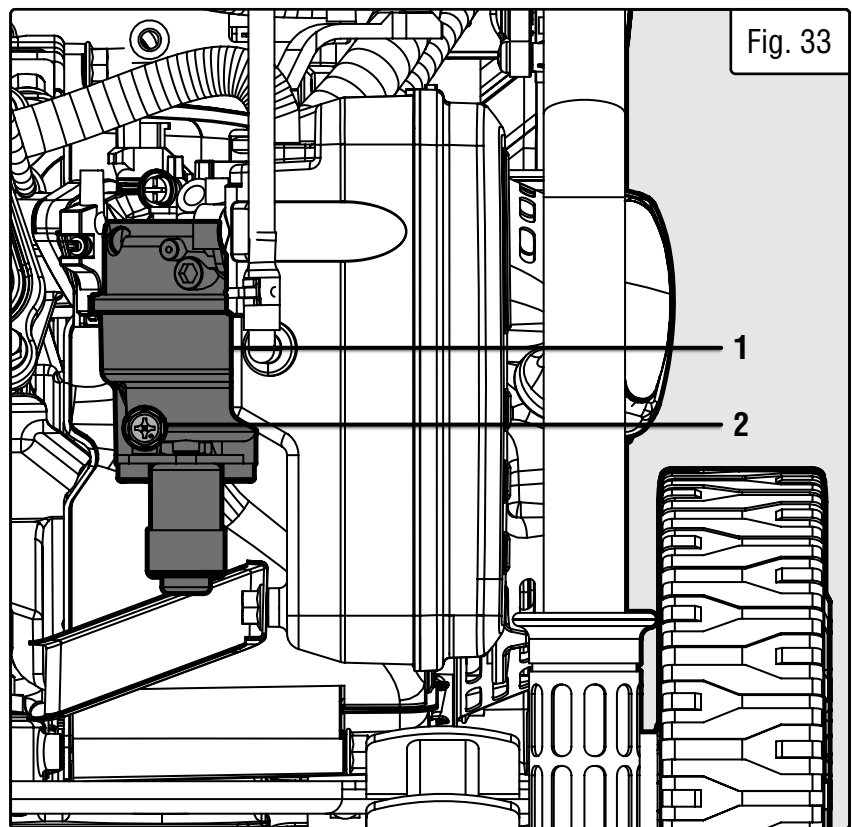

CAUTION: Store the emptied gasoline in a suitable place. Never store fuel for more than 2 months.

BATTERY MAINTENANCE/STORAGE

The battery will receive charge when the engine is running. Remember to run the generator once a month for 20-30 minutes to charge the battery. A charged battery will allow you to start the generator using the electric start switch during your next time of need. If the battery is out of charge, you may start the generator using the recoil starter. If the generator is not used for a long period, it is recommended to disconnect the quick-connector from the battery to protect it from losing charge.

TIP: You can also connect the battery to an automatic trickle charger to keep the battery charged. If using a trickle-charger, charge the battery at room temperature.

To reinstall/replace the battery:

1. Using a 10mm socket, remove the bolt on the bottom of the battery bracket and remove the bracket and battery (Fig. 35).
2. Replace with an identical new battery
(part no. DG4500iX-074).
3. Connect the new battery by connecting the two ends of the quick connector together.
4. Replace the battery bracket and bolt.

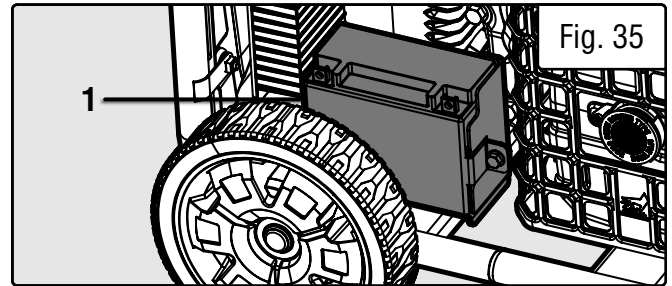

NOTE: Always recycle used batteries in accordance with local laws and regulations. Contact your local solid waste collection site or recycling facility to obtain information on local recycling processes.

TRANSPORTATION & STORAGE

TRANSPORTING THE GENERATOR

To prevent fuel spillage when transporting, be sure to perform the following:

1. Tighten the fuel cap.
2. Turn the FUEL SELECTOR knob to the "ENGINE OFF" position.
3. Drain the fuel tank if possible. Refer to section "DRAINING THE FUEL TANK."
4. Keep the generator upright. Never place the generator on its side or upside down - doing so could damage the internal components of the generator and make it difficult to start.

 **WARNING!** Avoid direct sunlight inside a vehicle. If the generator is left in an enclosed vehicle for many hours, the high temperature could cause the fuel to vaporize and result in a possible explosion.

STORING THE GENERATOR

Shut off the generator and allow the unit to cool to room temperature before storing it. NEVER place any type of storage cover on the generator while it is still hot. Do not obstruct any ventilation openings.

Follow the procedures below for properly storing your generator. We highly recommend running your generator once a month for 20 to 30 minutes. Plug in a small load in to ensure there is proper power output.

For Short Periods (30 to 60 Days):

- Drain the carburetor. Refer to page 33, "Draining the Carburetor."
- Disconnect the quick-connector from the battery.
- **Add fuel stabilizer:** Follow the suggested portions and instructions of your preferred stabilizer. Run the engine for 15 to 20 minutes, allowing the fuel stabilizer to mix with the gasoline and circulate through the carburetor, and then top off with fuel. Filling the fuel tank full reduces the amount of air in the tank and helps fight deterioration of fuel.

For Extended Periods (Over 60 Days):

- Disconnect the quick-connector from the battery.
- Drain the fuel tank and carburetor (see "Draining the Fuel Tank"). Never store generator with fuel in the tank for more than two months.
- Change the engine oil (see "CHANGING OIL").

 **WARNING!** Store the generator upright in a cool and dry location, away from sources of heat, open flames, sparks or pilot lights.

PRODUCT DISPOSAL

Do not dispose of a used generator or parts with your household waste. This product contains electrical or electronic components that should be recycled. Please take this product to your local recycling facility for responsible disposal to minimize its environmental impact.

Do not dispose of used oil or fuel in the trash or down a drain. Please contact your local recycling center or auto garage to arrange proper oil/fuel disposal.



Please recycle the packaging and electronic components where facilities exist. Please contact your local auto garage or recycling facility to properly dispose of oil/fuel.

TROUBLESHOOTING GUIDE

⚠ WARNING! Stop using the generator immediately if any of the following problems occur or risk serious personal injury. If you have any questions, please contact customer service at **1-800-232-1195** (M-F 8-5 CST), or email **techsupport@wenproducts.com**.

| PROBLEM | POSSIBLE CAUSE | SOLUTION |
|---|--|---|
| Engine will not start. | 1. CHOKE lever is in wrong position. | 1. Set switch to CHOKE if engine is cold and RUN if engine is warm. |
| | 2. Engine switch is set to OFF. | 2. Turn engine switch to START. |
| | 3. Engine has not been primed (LPG only). | 3. Prime the engine. |
| | 4. Battery is out of power. | 4. Electric start will not work if battery is out of power. Start generator using the recoil start to charge the battery. |
| | 5. Battery is too cold. | 5. Electric start may be difficult if the battery is too cold. Store the generator or battery in a warmer location. |
| | 6. Oil is low. | 6. Add oil. |
| | 7. Engine is out of fuel. | 7. Add fuel. |
| | 8. Engine is filled with contaminated or old fuel. | 8. Drain fuel in the tank and carburetor. Replace with fresh fuel. |
| | 9. Spark plug is dirty or broken. | 9. Clean or replace spark plug. |
| | 10. Propane tank is turned OFF. | 10. Dang it, Bobby, I told you to turn that thing on! |
| | 11. Carburetor is air locked. | 11. Turn the FUEL SELECTOR SWITCH to OFF. Remove bolt from bottom of the carburetor. Take off the carburetor bowl to allow it to reset. Replace carburetor bowl and reinstall the bolt. |
| | 12. Regulator is stuck. | 12. Turn OFF propane tank. Disconnect hose from propane fitting. Contact WEN customer service for assistance. |
| | 13. Ghost in the generator. | 13. Persuade ghost to leave. Consult Bill Murray if needed. |
| Engine runs, but there is no electrical output. | 1. Reset button has activated due to wattage overload. | 1. Turn off and unplug all electrical devices. Press reset button. Check the total wattage of the devices and reduce the load if it exceeds the capacity of the generator for your particular fuel (LPG or gasoline). |
| | 2. Breaker has tripped due to wattage overload. | 2. Turn off and unplug all electrical devices. Wait 3 minutes, and press the activated breaker to reset. Check the total wattage of the devices and reduce the load if it exceeds the capacity of the generator for your particular fuel (LPG or gasoline). |
| | 3. Bad connecting cord or wire. | 3. Check power cords & extension cords. Do not use if any cord is damaged. Replace damaged cords immediately. |
| | 4. Bad electrical device connected to the generator. | 4. Try connecting a different device. |
| Generator runs, but does not support all electrical devices connected. | 1. AC or DC receptacles are overloaded; circuit breaker has tripped. | 1. Turn off and unplug all electrical devices. Wait 3 minutes, then press the breaker to reset. Check the amperage of the devices to ensure they are within the receptacles' rated capacities. |
| | 2. Short circuit in one of the devices. | 2. Disconnect any faulty or short-circuited electrical devices. |
| | 3. Air filter is dirty. | 3. Clean or replace the air filter element. |
| Engine is "hunting" during operation (engine RPM is fluctuating). | 1. Gasoline is not running through fuel valve. | 1. Make sure there is enough fuel. Make sure the CHOKE lever is turned to RUN. |
| | 2. Propane level is getting low. | 2. Switch to a new propane tank, or use gasoline. |
| | 3. Air filter is dirty. | 3. Clean or replace the air filter element. |
| | 4. Spark arrestor is dirty. | 4. Clean the spark arrestor. |
| | 5. There is gunk in the carburetor preventing a consistent fuel/air mixture. | 5. Use carburetor cleaner spray on the carburetor bowl and jets. |

IMPORTANT: Repairs and replacements should only be performed by an authorized technician. Parts and accessories that wear down over the course of normal use are not covered by the three-year warranty.