

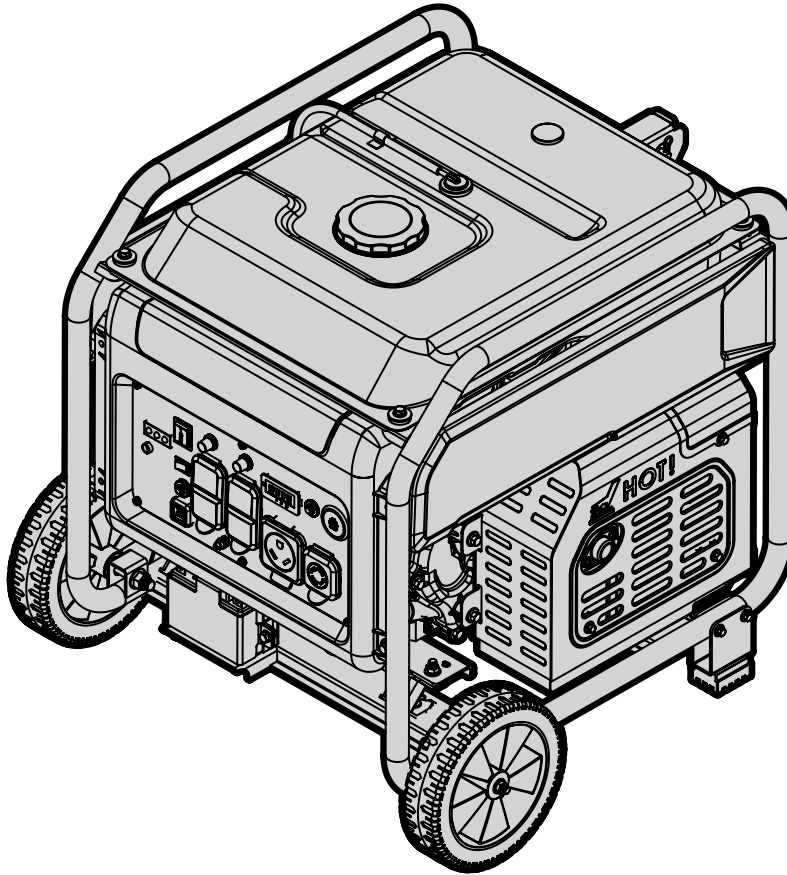

MODEL DF875iX

8750-WATT INVERTER GENERATOR

Instruction Manual



NEED HELP? CONTACT US!

Have product questions? Need technical support? Please feel free to contact us:



1-800-232-1195 (M-F 8AM-5PM CST)



TECHSUPPORT@WENPRODUCTS.COM

IMPORTANT: Your new tool has been engineered and manufactured to WEN's highest standards for dependability, ease of operation, and operator safety. When properly cared for, this product will supply you years of rugged, trouble-free performance. Pay close attention to the rules for safe operation, warnings, and cautions. If you use your tool properly and for its intended purpose, you will enjoy years of safe, reliable service.

For replacement parts and the most up-to-date instruction manuals, visit ***WENPRODUCTS.COM***

CONTENTS

WELCOME	3
Specifications.....	3
Introduction	4
SAFETY	5
General Safety Rules.....	5
Generator Safety Warnings	7
BEFORE OPERATING	9
Unpacking & Packing List.....	9
Know Your Generator.....	10
Assembly & Adjustments.....	12
Generator Preparation.....	14
OPERATION & MAINTENANCE	19
Starting the Generator.....	19
Using the Generator	26
Shutting Off the Generator	32
Maintenance.....	33
Transportation & Storage.....	39
Troubleshooting Guide.....	40
Wiring Diagram.....	42
Exploded View & Parts List.....	43
Warranty Statement	51

To purchase accessories for your tool, visit ***WENPRODUCTS.COM***

Weatherproof Generator Cover (Model 56409, GNC875)

Magnetic Oil Dipstick (Model GNA200)

SPECIFICATIONS

GENERATOR

Model Number	DF875iX
Surge (Starting) Wattage	Gas: 8750W LPG: 7800W
Rated (Running) Wattage	Gas: 7000W LPG: 6300W
Rated Voltage	120V / 240V AC
Phase	Single
Frequency	60 Hz
Product Weight With Wheel Kit	140 lbs
Product Weight Without Wheel Kit	134.5 lbs
Product Dimensions With Wheel Kit	26.8 in. x 26.4 in. x 23.2 in.
Product Dimensions Without Wheel Kit	23.8 in. x 20.2 in. x 21.1 in.

ENGINE

Engine Type	4 stroke, OHV, single cylinder with forced air cooling system
Engine Displacement	420 cc
Fuel Tank Capacity	4.2 gallons (16.0 L)
Oil Capacity	37.2 fl oz (1.1 L)
Half-Load Run Time	Gas: 6.7 hours
	LPG: 5.5 hours on a 20-lb tank
Lubrication System	Forced Splash
Spark Plug Type	Torch F7RTC (NGK BPR7ES)
Spark Plug Gap	0.7 - 0.8 mm (0.028 - 0.031 in.)
Spark Plug Torque	½ - ¾ turn after gasket contacts base or 15 ft-lbs (20.33 Nm)

INTRODUCTION

Thanks for purchasing the WEN 8750-Watt Dual Fuel Inverter Generator. Refer to the illustration below for the location of the serial number on the specifications label. Record the generator information in the spaces provided below. If assistance for information or service is required, please contact customer service by calling **1-800-232-1195**, M-F 8-5 CST; you will be asked to provide the following generator information when calling.

Generator Model Number: DF875iX

Date of Purchase: _____

Purchased From: _____

Serial Number: _____



MODEL DF875iX

8750 WATT INVERTER GENERATOR

RATED WATTAGE	GAS: 7000W LPG: 6300W	RATED FREQUENCY	60 Hz
SURGE WATTAGE	GAS: 8750W LPG: 7800W	RATED VOLTAGE	120V / 240V
SERIAL NO.			
ENGINE SERIAL NO.			

TYPE 1
MADE IN CHINA

1-800-232-1195 WENPRODUCTS.COM

Great Lakes Technologies LLC • 1101 Wesemann Drive • West Dundee, IL 60118

Serial Number →

SERVICE RECORD

Record the service dates of your generator in the chart below. Please perform maintenance checks and operations according to the "Maintenance" section of the manual.

Service Record	Date	Date	Date	Date	Date	Date
Change Oil						
Change Spark Plug						
Clean Fuel Tank						
Clean Air Cleaner						
Clean Spark Arrestor						

TO MAXIMIZE THE LIFESPAN OF YOUR GENERATOR: We recommend running your generator at least once a month for 20 to 30 minutes. Start the generator according to the instructions and plug a small load in to make sure the outlet is producing electricity.

GENERAL SAFETY RULES

 **WARNING!** Read all safety warnings and all instructions. Failure to follow the warnings and instructions may result in electric shock, fire and/or serious injury.

Safety is a combination of common sense, staying alert and knowing how your item works. The term “power tool” in the warnings refers to your mains-operated (corded) power tool or battery-operated (cordless) power tool.

SAVE THESE SAFETY INSTRUCTIONS.

WORK AREA SAFETY

- 1. Keep work area clean and well lit.** Cluttered or dark areas invite accidents.
- 2. Do not operate power tools in explosive atmospheres, such as in the presence of flammable liquids, gases or dust.** Power tools create sparks which may ignite the dust or fumes.
- 3. Keep children and bystanders away while operating a power tool.** Distractions can cause you to lose control.

ELECTRICAL SAFETY

- 1. Power tool plugs must match the outlet. Never modify the plug in any way. Do not use any adapter plugs with earthed (grounded) power tools.** Unmodified plugs and matching outlets will reduce risk of electric shock.
- 2. Avoid body contact with earthed or grounded surfaces such as pipes, radiators, ranges and refrigerators.** There is an increased risk of electric shock if your body is earthed or grounded.
- 3. Do not expose power tools to rain or wet conditions.** Water entering a power tool will increase the risk of electric shock.
- 4. Do not abuse the cord. Never use the cord for carrying, pulling or unplugging the power tool. Keep cord away from heat, oil, sharp edges or moving parts.** Damaged or entangled cords increase the risk of electric shock.
- 5. When operating a power tool outdoors, use an extension cord suitable for outdoor use.** Use of a cord suitable for outdoor use reduces the risk of electric shock.

- 6. If operating a power tool in a damp location is unavoidable, use a ground fault circuit interrupter (GFCI) protected supply.** Use of a GFCI reduces the risk of electric shock.

PERSONAL SAFETY

- 1. Stay alert, watch what you are doing and use common sense when operating a power tool. Do not use a power tool while you are tired or under the influence of drugs, alcohol or medication.** A moment of inattention while operating power tools may result in serious personal injury.
- 2. Use personal protective equipment. Always wear eye protection.** Protective equipment such as a respiratory mask, non-skid safety shoes and hearing protection used for appropriate conditions will reduce the risk of personal injury.
- 3. Prevent unintentional starting. Ensure the switch is in the off-position before connecting to power source and/or battery pack, picking up or carrying the tool.** Carrying power tools with your finger on the switch or energizing power tools that have the switch on invites accidents.
- 4. Remove any adjusting key or wrench before turning the power tool on.** A wrench or a key left attached to a rotating part of the power tool may result in personal injury.
- 5. Do not overreach. Keep proper footing and balance at all times.** This enables better control of the power tool in unexpected situations.
- 6. Dress properly. Do not wear loose clothing or jewelry. Keep your hair and clothing away from moving parts.** Loose clothes, jewelry or long hair can be caught in moving parts.

GENERAL SAFETY RULES

⚠ WARNING! Read all safety warnings and all instructions. Failure to follow the warnings and instructions may result in electric shock, fire and/or serious injury.

Safety is a combination of common sense, staying alert and knowing how your item works. The term “power tool” in the warnings refers to your mains-operated (corded) power tool or battery-operated (cordless) power tool.

SAVE THESE SAFETY INSTRUCTIONS.

7. If devices are provided for the connection of dust extraction and collection facilities, ensure these are connected and properly used. Use of dust collection can reduce dust-related hazards.

POWER TOOL USE AND CARE

1. Do not force the power tool. Use the correct power tool for your application. The correct power tool will do the job better and safer at the rate for which it was designed.

2. Do not use the power tool if the switch does not turn it on and off. Any power tool that cannot be controlled with the switch is dangerous and must be repaired.

3. Disconnect the plug from the power source and/or the battery pack from the power tool before making any adjustments, changing accessories, or storing power tools. Such preventive safety measures reduce the risk of starting the power tool accidentally.

4. Store idle power tools out of the reach of children and do not allow persons unfamiliar with the power tool or these instructions to operate the power tool. Power tools are dangerous in the hands of untrained users.

5. Maintain power tools. Check for misalignment or binding of moving parts, breakage of parts and any other condition that may affect the power tool's operation. If damaged, have the power tool repaired before use. Many accidents are caused by poorly maintained power tools.

6. Keep cutting tools sharp and clean. Properly maintained cutting tools with sharp cutting edges are less likely to bind and are easier to control.

7. Use the power tool, accessories and tool bits, etc. in accordance with these instructions, taking into account the working conditions and the work to be performed. Use of the power tool for operations different from those intended could result in a hazardous situation.

8. Use clamps to secure your workpiece to a stable surface. Holding a workpiece by hand or using your body to support it may lead to loss of control.

9. KEEP GUARDS IN PLACE and in working order.

SERVICE

1. Have your power tool serviced by a qualified repair person using only identical replacement parts. This will ensure that the safety of the power tool is maintained.

CALIFORNIA PROPOSITION 65 WARNING

Some dust created by power sanding, sawing, grinding, drilling, and other construction activities may contain chemicals, including lead, known to the State of California to cause cancer, birth defects, or other reproductive harm. Wash hands after handling. Some examples of these chemicals are:

- Lead from lead-based paints.
- Crystalline silica from bricks, cement, and other masonry products.
- Arsenic and chromium from chemically treated lumber.

Your risk from these exposures varies depending on how often you do this type of work. To reduce your exposure to these chemicals, work in a well-ventilated area with approved safety equipment such as dust masks specially designed to filter out microscopic particles.

GENERATOR SAFETY WARNINGS

DANGER! CARBON MONOXIDE

Using a generator indoors **CAN KILL YOU IN MINUTES**. Generator exhaust contains carbon monoxide (CO). This is a poison gas you cannot see or smell. If you can smell the generator exhaust, you are breathing CO. But even if you cannot smell the exhaust, you could be breathing CO.





NEVER use a generator inside homes, garages, crawl spaces, or other partially enclosed areas. Deadly levels of carbon monoxide can build up in these areas. Using a fan or opening windows and doors does **NOT** supply enough fresh air. **ONLY** use a generator outside and far away from windows, doors, and vents. These openings can pull in generator exhaust.

Even if you use a generator correctly, CO may leak into the home. **ALWAYS** use a battery-powered or battery-backup CO alarm in the home. If you start to feel sick, dizzy, or weak after the generator has been running, move to fresh air **RIGHT AWAY**. See a doctor. You may have carbon monoxide poisoning.

 **WARNING! RISK OF EXPLOSION. HIGHLY FLAMMABLE:** This generator may emit highly flammable and explosive gasoline vapors, which can cause severe burns or even death, if ignited. A nearby open flame can lead to explosion even if not directly in contact with gasoline.

- Do not operate near open flame, heat, or any other ignition source. Do not smoke near the generator.
- Always operate on a firm, level surface.
- Always turn generator off before refueling. Allow generator to cool for at least 2 minutes before removing fuel cap. Loosen cap slowly to relieve pressure in tank.
- Do not overfill fuel tank. Gasoline may expand during operation. Do not fill to the top of the tank. Allow for expansion. Always check for spilled fuel before operating.
- If fuel spills, move the generator at least 30 feet away from the spill and wipe clean any spilled fuel before starting the engine.
- Empty fuel tank before storing or transporting the generator.

 **WARNING!** If this generator is used as a supply for a building's wiring system, the generator must be installed by a qualified electrician and connected to a transfer switch as a separately derived system in accordance with all applicable laws and electrical codes and the National Electrical Code, NFPA 70. The generator shall be connected to a transfer switch that switches all conductors excluding the equipment grounding conductor. The frame of the generator shall be connected to an approved grounding electrode.

 **CALIFORNIA PROPOSITION 65 WARNING:** This product contains chemicals and produces exhaust known to the State of California to cause cancer, birth defects and other reproductive harm. For more information, visit www.P65Warnings.ca.gov

GENERATOR SAFETY WARNINGS

⚠ WARNING! Do not let comfort or familiarity with the product replace strict adherence to product safety rules. Failure to follow the safety instructions may result in serious personal injury.

OPERATING ENVIRONMENT

1. **Using a generator indoors can kill you in minutes.** Only use a generator outside and far away from windows, doors and vents.

2. **Do not smoke near the generator.**

3. **Do not operate near open flame, heat, or flammable materials.** This generator may emit highly flammable and explosive gasoline vapors, which can cause severe burns or even death if ignited. A nearby open flame can lead to an explosion even if it isn't directly in contact with gasoline.

4. **Do not expose the generator to rainy or wet conditions; doing so significantly increases the risk of electrical shock.** Never handle the generator, electronic devices, or any cord while standing in water, while bare-foot, or when hands or feet are wet.

5. **Always operate the generator on a dry, firm, level surface.**

6. **The generator should have at least 5 feet of clearance from buildings or other equipment during operation.**

7. **Do not allow children or non-qualified persons to operate the generator.**

GENERATOR PREPARATION

1. **Always ground the generator before using it to maximize safety** (see "Ground the Generator" section).

2. **Do not overfill fuel tank, as gasoline may expand during operation.** Do not fill to the very top of the tank. Leave room for gasoline expansion. Always check for spilled fuel before operating.

3. **If any part of the generator, electrical device or power cord is broken, damaged, or defective, make sure it is repaired or replaced before operation.** Service should only be performed by a qualified technician. Do not use receptacles or cords that show signs of damage, such as broken or cracked insulation.

4. **Use a ground fault circuit interrupter (GFCI) in highly conductive areas such as metal decking or steel work.** Extension cords with in-line GFCIs are recommended for these operations to maximize safety.

5. **If connecting the generator to a building's electrical system for standby power, you MUST consult a qualified electrician and install a transfer switch.** Such connections must comply with local electrical laws and codes. Failure to comply can create a back-feed, which may result in serious injury or death to utility workers.

6. **Never modify the generator in any way.** Modifying or using the machine for any other purpose for which it is not designed may result in serious injuries, machine damage and voiding of the warranty.

GENERATOR OPERATION

1. **Only use the generator for its intended purposes.** Modifying or using the generator for operations for which it was not designed may cause hazards and personal injury.

2. **Do not touch bare wires or receptacles (outlets).**

3. **Do not exceed the wattage capacity of the generator by plugging in more electrical devices than the unit can handle.** This could damage the generator and/or connected electrical devices. Check the operating voltage and frequency requirements of all electrical devices prior to plugging them into the generator.

TO MAXIMIZE THE LIFESPAN OF YOUR GENERATOR: We recommend running your generator at least once a month for 20 to 30 minutes. Start the generator according to the instructions and plug a small load in to make sure the outlet is producing electricity. If you do not run it often, it will greatly shorten the generator's lifespan and void the warranty.

KNOW YOUR GENERATOR

TOOL PURPOSE

Generators provide you with power when and where you need it most. Refer to the following diagrams to become familiarized with all the parts and controls of your Generator. The components will be referred to later in the manual for assembly and operation instructions.

GENERATOR

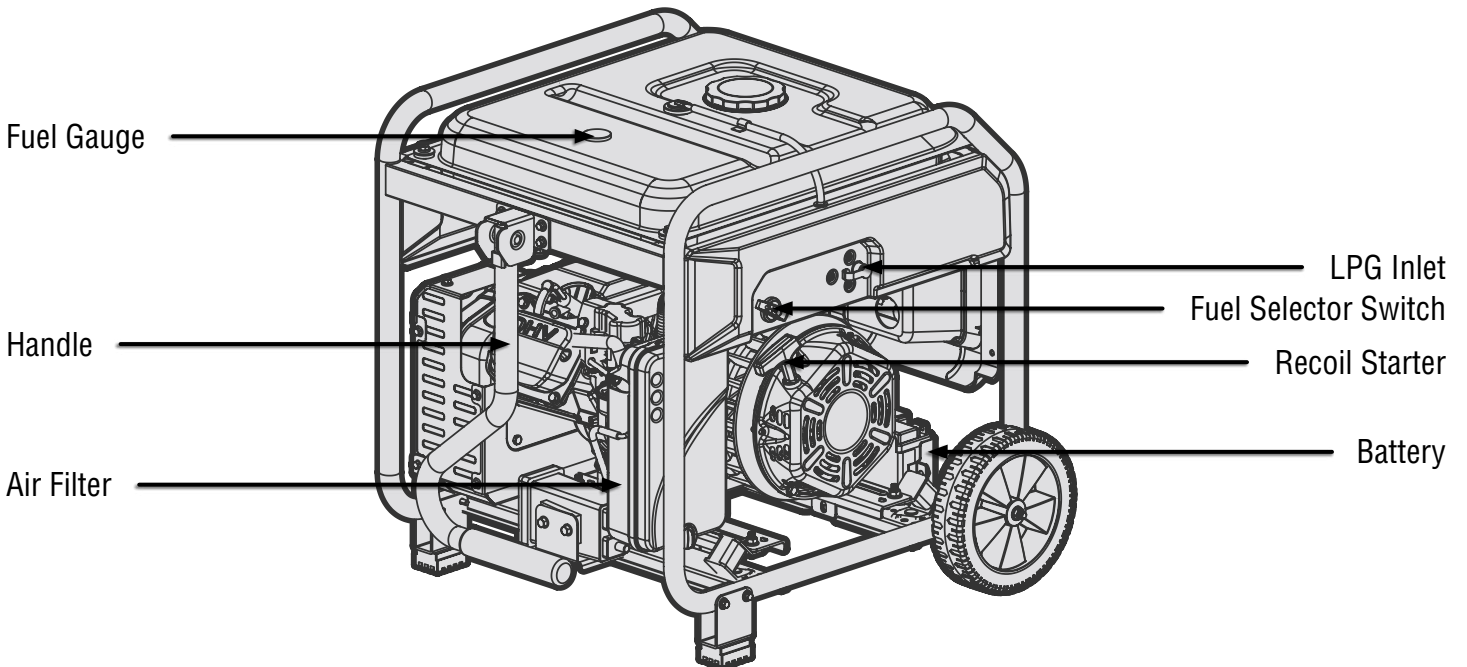
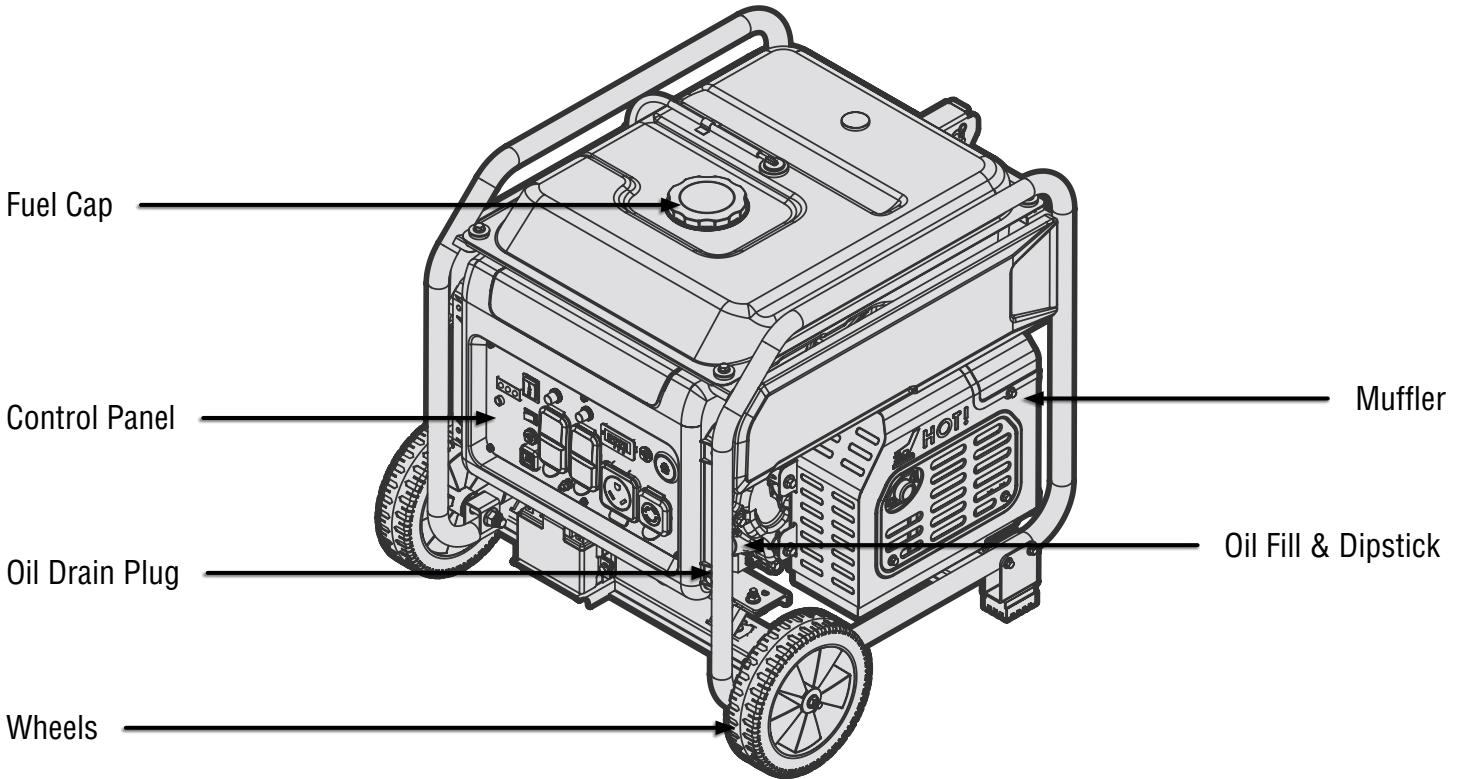

KNOW YOUR GENERATOR

CONTROL PANEL

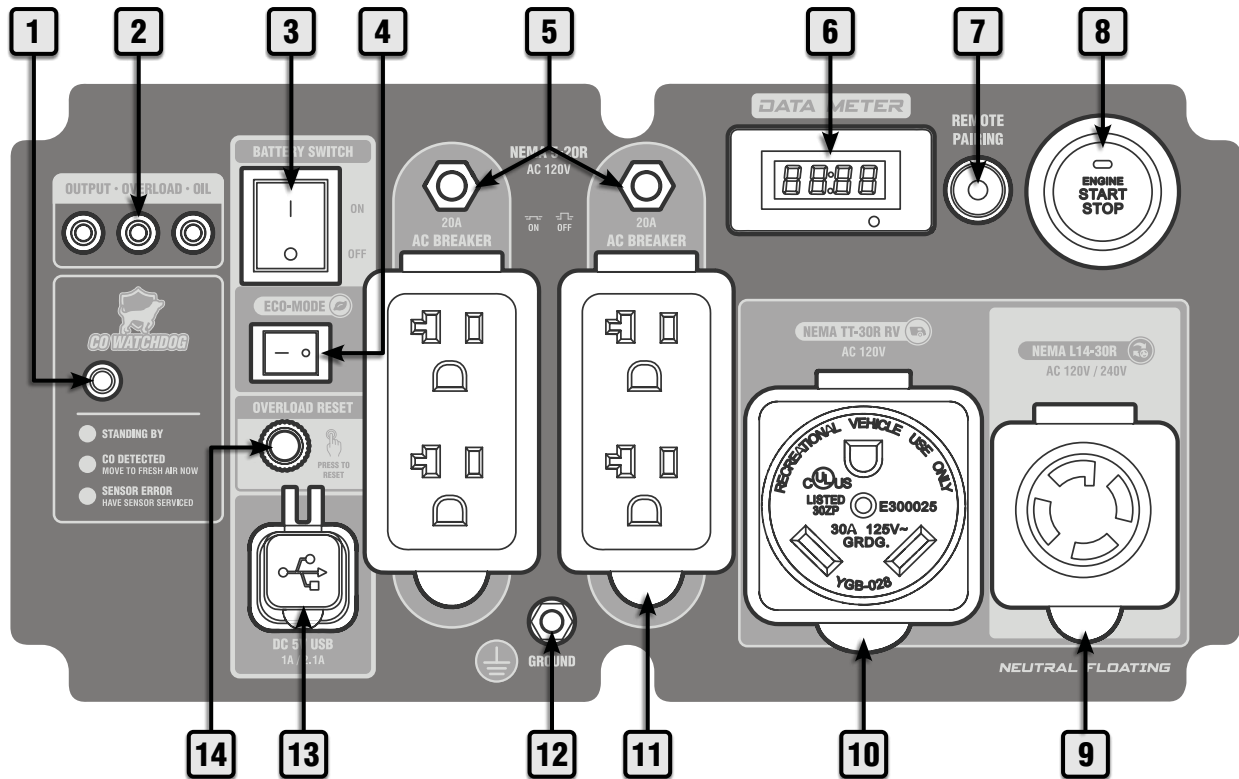

1. CO WATCHDOG Carbon Monoxide Monitor

Measures the accumulation of poisonous CO gas while the generator is running. If the level of CO gas gets too high, the CO Watchdog system will automatically shut down the generator. See p. 31 for more information.

2. Indicator Lights

Output light (green) will turn on when receptacles have power, overload light (red) will turn on if the generator is overloaded, the oil light (yellow) will turn on if the oil is low.

3. Battery Switch

Control whether or not the battery is connected to the control panel. Always turn the battery switch OFF to conserve power after shutting down the generator. You can also shut down the generator by turning the battery switch OFF.

4. Eco-Mode Switch

Flip this switch to ON to increase fuel economy and runtime when the load is below 75% of the rated load (5250W gasoline, 4725W LPG).

5. Circuit Breakers

Push the button to reset the circuit.

6. Data Meter

Displays voltage, frequency, total runtime (HHHH), and session runtime (HH:MM). Press the MODE button to switch between displays.

7. Remote Pairing Button

Use this button to pair the remote and generator. See “Remote Start” section (pages 23 - 24) for more information.

8. Engine Start / Stop Button

Use this button to start or stop the generator. The button will also flash different colors to provide important information about your generator. See “Starting the Generator” (page 21) and “Shutting Off the Generator” (page 32) sections for more information.

9. NEMA L14-30R

AC 120V/240V split-phase.

10. AC 120V NEMA TT-30R

Standard RV connector.

11. AC 120V NEMA 5-20R Duplex Receptacles

20A standard household outlets.

12. Grounding Nut

13. DC 5V USB Ports

The upper USB port provides 2.1A, while the lower port provides 1A of power.

14. Overload Reset Button

If the overload light is ON, press this button to reset.

ASSEMBLY & ADJUSTMENTS

HIGH ALTITUDE OPERATION ABOVE 3000 FEET

The fuel system on this generator may be affected by operation at high altitudes. Proper operation can be ensured by installing an altitude kit at altitudes higher than 3000 feet above sea level. At elevations above 8000 feet, the engine may experience a decrease in performance, even with the proper altitude kit. Operating this generator without the high altitude kit at elevations above 3000 feet may increase the engine's emissions and decrease both fuel economy and performance.

NOTE: If you plan to only use propane at high altitudes, a high-altitude kit is not required. High-altitude kits are only required if you plan to use gasoline at high altitudes.

INSTALLING THE HIGH ALTITUDE KIT

This kit should be installed by a qualified mechanic. Contact customer service at **1-800-232-1195** (M-F 8-5 CST), or email techsupport@wenproducts.com for information about service centers near you. Two high-altitude kits (part numbers **DF875iX-HA36** and **DF875iX-HA68**) are included with your generator.

Gather the parts in the high altitude kit.

1. Flip the engine switch to the STOP position.
2. Turn the fuel valve to the OFF position.
3. Prepare an approved gasoline-storage container to catch any spilled fuel. Place it near the fuel valve.
4. The carburetor can be accessed from the backside of the generator between the engine and the air filter. Loosen the screws (Fig. 1) on the bottom of the carburetor with a Phillipshead screwdriver (not included). **CAUTION! The carburetor bowl may have gas in it which will leak upon loosening the screws and removing the solenoid.**
5. Remove the screws, solenoid, solenoid seal, bolt, bolt seal, fuel cup, fuel cup seal, and main jet from the body of the carburetor assembly (Fig. 1).

6. Replace the main jet with the replacement jet needed for your altitude range (3000-6000 ft or 6000-8000 ft). **NOTE: The fuel cup seal, bolt seal and solenoid seal may be damaged during removal and should be replaced with the new ones from the kit.**

7. Reassemble the fuel cup seal, fuel cup, bolt seal, bolt, solenoid seal, solenoid and screws. Tighten with a Phillips-head screwdriver to secure.

8. Wipe up any spilled fuel and allow excess to evaporate before starting the engine. **WARNING! To prevent fire, do not start the engine while the smell of fuel hangs in the air.**

⚠ WARNING! To prevent serious injury from fire, follow the kit installation procedures in a well-ventilated area away from ignition sources. If the engine is hot from use, shut the engine off and wait for it to cool before proceeding. Do not smoke near the generator. Warranty will be void if adjustments are not made for high altitude use.

CAUTION! UNINSTALL the high altitude kit when operating at altitudes below 3000 feet.

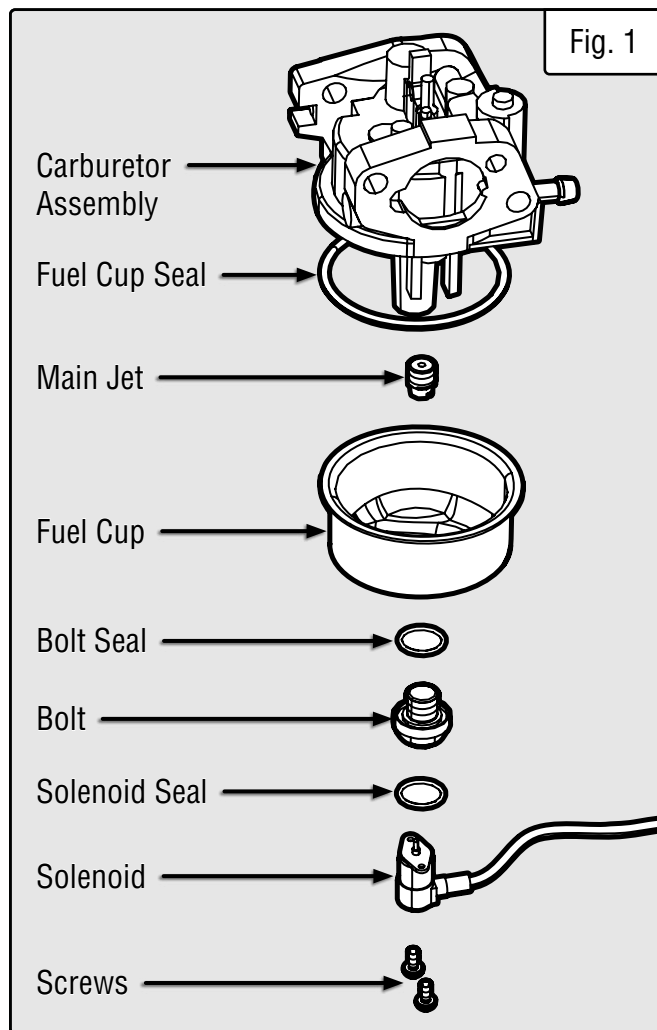

CAUTION! UNINSTALL the high altitude kit when operating at altitudes below 3000 feet.

ASSEMBLY & ADJUSTMENTS

⚠ WARNING! Do not turn on the generator until it is fully assembled according to the instructions. Read through and become familiarized with the following procedures of handling and adjusting your tool. Failure to follow the safety instructions may result in serious personal injury.

- Never use the handle as a lifting point to support the entire weight of the generator. Only use the handle to pull the generator with the help of the wheels.
- Use caution when collapsing the handle. Hands and fingers could get caught and pinched.

ASSEMBLY

Refer to the packing list to gather the proper parts and tools for installing the feet, wheels, and handles.

NOTE: There are different sizes of bolts/nuts; be sure to use the proper bolts/nuts for each assembly step.

REMOVING THE SHIPPING BRACKETS

1. Your generator comes with two red shipping brackets installed to help prevent shipping damage. Failure to remove these brackets can damage the engine. Make sure to remove these brackets **BEFORE** adding oil or gasoline.
2. Gently tip the generator onto its side. Use the included wrenches (or a socket set) to remove the nuts and bolts that hold the shipping brackets to the bottom of the engine crankcase.
3. Once the shipping brackets are removed, they may be recycled. You will not need them.

INSTALLING THE FEET

The feet are installed on the muffler and air filter sides of the generator.

1. Prepare a set of blocks on level ground (a 4×4 block of wood works well). Place the generator on the blocks. Have someone help you lift the generator.
2. Slide one foot into place on the generator frame and align the holes on the foot with the holes on the frame.
3. Slide the M6x40 bolts through the legs and generator frame. Tighten the M6 nuts onto the bolts using a wrench.
4. Repeat on the opposite side.

INSTALLING THE WHEELS

1. Remove the nuts from the axles.
2. Insert the thick side of the axle through the generator frame. Install and tighten the nut.
3. Slide the wheel onto the thin side of the axle. Install and tighten the nut.

NOTE: You can use a wrench on the hex shank of the axle to hold it steady when tightening the nuts.

INSTALLING THE HANDLE

1. Install the bracket on the top of the generator frame using the four M6x30 bolts. Tighten using a wrench.
2. Insert the handle pin through the bracket and handle. Secure it using the R-clip.

NOTE: Refer to the instructions on the following pages before starting your generator.

GENERATOR PREPARATION

The following section describes the necessary steps to prepare the generator for use. If you are unsure about how to perform any of the steps please call **1-800-232-1195** (M-F 8-5 CST) for customer service. Failure to perform these steps properly can damage the generator or shorten its life.

STEP 1 - ADD/CHECK OIL

The generator is shipped without oil. User must add the proper amount of oil before operating the generator for the first time. The oil capacity of the engine crankcase is **37.2 fl oz (1.1 L)**.

ENGINE OIL RECOMMENDATIONS

Select good quality detergent oil bearing the American Petroleum Institute (API) service classifications SJ, SL, or SM (synthetic oils may be used). Select the SAE viscosity grade of oil that matches the expected operating temperature.

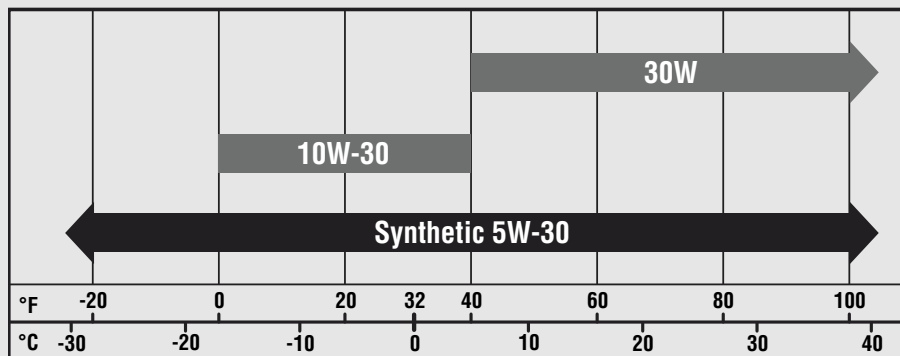

Fig. 2

- **30W Engine Oil**
Temperatures above 40°F
- **10W-30 Engine Oil**
Temperatures between 0°F - 40°F
- **Synthetic 5W-30 Engine Oil**
All temperature ranges

TO ADD OIL:

1. Place the generator on a level surface. Make sure the engine is OFF before adding or checking oil.

CAUTION! Keep the generator level. Tilting the generator to assist in filling will cause oil to flow into the wrong areas of the engine and cause damage.

2. Unscrew the oil dipstick (Fig. 3) from the engine.

3. Using an oil funnel or appropriate dispenser, slowly add oil into the oil fill, being careful not to overfill the unit. Fill the crankcase to the upper fill line so you can visually see the oil coming halfway up the oil fill threads. See Fig. 4.

4. Reinstall the oil dipstick and firmly tighten it. Wipe clean any spilled oil.

CAUTION! For subsequent operation, the oil level should be checked before each use, or after every 8 hours of operation. The generator is equipped with a low-oil sensor and will not start without a sufficient amount of oil. Follow the instructions on the next page to check the oil level.

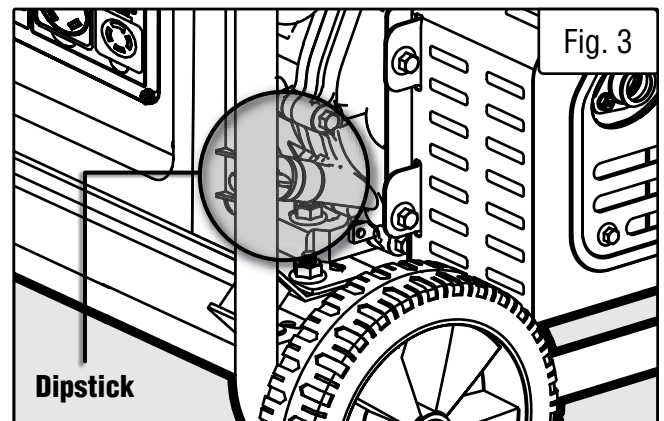

Fig. 3

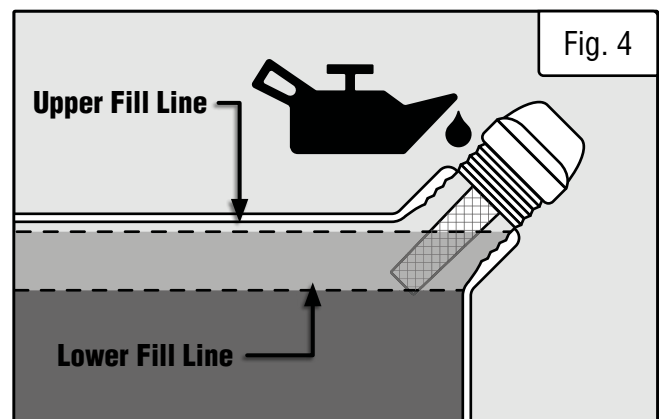
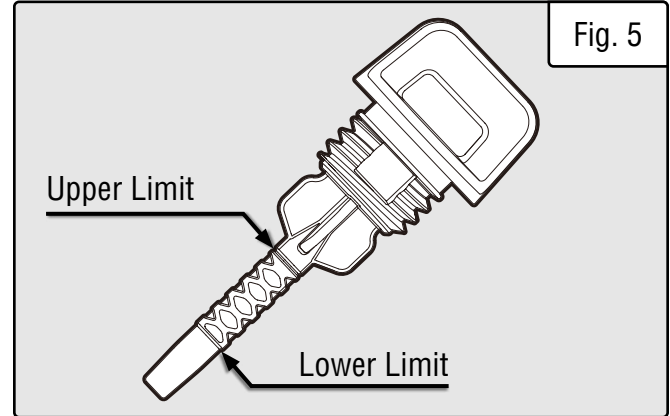

Fig. 4

GENERATOR PREPARATION

TO CHECK OIL LEVEL (before every subsequent start):

1. Place the generator on a level surface. Make sure the engine is OFF before adding or checking oil.
2. Remove and wipe the dipstick with a clean rag.
3. Insert the dipstick into the oil fill without screwing it in. Remove the dipstick to check the oil mark.
4. If the oil mark covers **less than one half** of the dipstick, slowly **add oil** until the oil mark reaches the top of the dipstick (or when you can see the oil coming halfway up the oil fill threads). See Fig. 5.



OIL LEVEL SHUTDOWN

To protect the unit from damage, the generator is equipped with a low-oil-pressure shutoff that will automatically shut down the engine when the oil level is too low. The oil level of the engine should be checked before each start to ensure that the engine crankcase contains sufficient lubricant.

STEP 2 - ADD/CHECK FUEL

FUEL OPTION A: GASOLINE

⚠ WARNING: RISK OF EXPLOSION. HIGHLY FLAMMABLE: This generator may emit highly flammable and explosive gasoline vapors, which can cause severe burns or even death, if ignited. A nearby open flame can lead to explosion even if not directly in contact with gasoline.

- Do not operate near open flame, heat, or any other ignition source. Do not smoke near the generator.
- Always operate on a firm, level surface.
- Always turn generator off before refueling. Allow generator to cool for at least 2 minutes before removing fuel cap. Loosen cap slowly to relieve pressure in tank.
- Do not overfill fuel tank. Gasoline may expand during operation. Do not fill to the top of the tank. Allow for expansion. Always check for spilled fuel before operating.
- If fuel spills, move the generator at least 30 feet away from the spill and wipe clean any spilled fuel before starting the engine.
- Empty fuel tank before storing or transporting the generator.

ONLY use fresh (within 30 days from purchase), lead-free gasoline with a **minimum of 87 octane rating**. The generator performs best with ethanol-free gasoline. **DO NOT** use gasoline with over 10% ethanol.

The capacity of the fuel tank is **4.2 US gallons (16.0L)**. Do not mix oil with gasoline.

Follow the instructions on the next page to add gasoline.

IMPORTANT:

- Avoid getting dirt or water into the fuel tank.
- Keep gasoline away from sparks, open flames, pilot lights, heat, and other sources of ignition.
- Gasoline can age in the tank and make starting difficult. Never store the generator for more than 2 months with fuel in the tank.
- Never use an oil/gasoline mixture.
- Never use old gasoline.

GENERATOR PREPARATION

TO ADD GASOLINE:

1. Place the generator on a level surface. Make sure the engine is OFF before adding or checking the fuel.
2. Unscrew the fuel cap (Fig. 6) and set it aside. The fuel cap may be tight and hard to unscrew.
3. Slowly add unleaded gasoline to the fuel tank. Be careful not to overfill. Reinstall fuel cap and wipe clean any spilled gasoline with a dry cloth.

NOTE: Do not fill the fuel tank to the very top. If you do so, gasoline will expand and spill during use, even with the fuel cap in place.

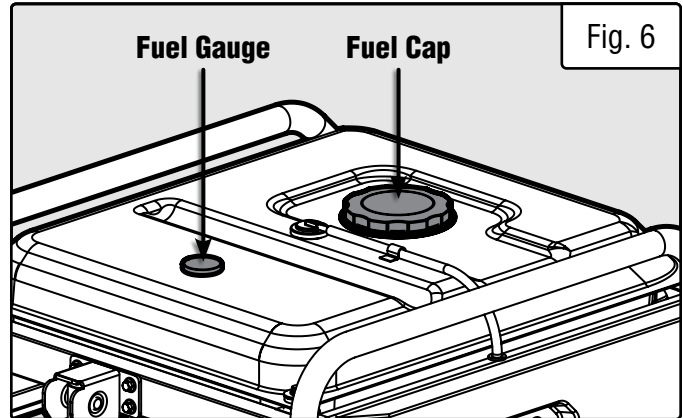

TO CHECK GAS LEVEL (before every subsequent start):

1. Before starting the generator, check the fuel gauge (Fig. 6) to see if there is sufficient fuel inside the tank:
 - E = Empty
 - F = Full
2. If the tank is empty add gasoline to the gas tank. See above section, "To Add Gasoline".

FUEL OPTION B: LIQUID PETROLEUM GAS (LPG)

To connect your generator to an LPG cylinder:

1. Take off the safety caps from the cylinder valve, generator mounted regulator, and regulator connecting hose ends.
2. With the LPG tank valve closed, attach the LPG regulator connecting hose to the valve. Turn the plastic coupling from the hose right (clockwise) to tighten hose assembly onto the LPG tank (Fig. 7).
3. Remove the protective rubber cover from the LPG inlet (Fig. 8 - 1) on the side of the generator. Connect the nut on the other end of the regulator connecting hose to the LPG inlet. Tighten the nut using the included 19mm wrench.

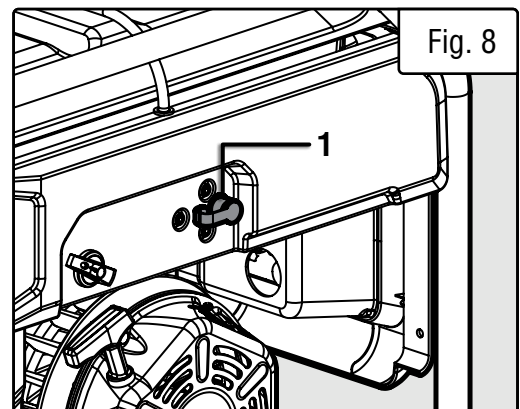
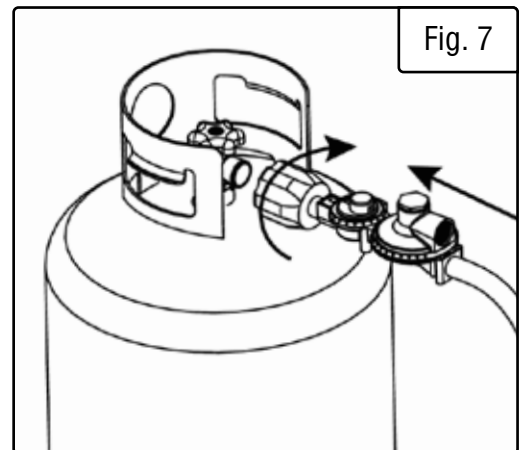

GENERATOR PREPARATION

FUEL OPTION B: LIQUID PETROLEUM GAS (LPG) (CONT.)

4. Turn the LPG tank valve ON (Fig. 9) and check for leaks by spraying soapy water to check connections. If bubbles appear, become larger in size, or increase in number, a leak exists. This **MUST** be corrected before using generator. Contact WEN customer service at **1-800-232-1195**, M-F 8-5 CST, or email **techsupport@wenproducts.com** for assistance.

NOTE: You can use Teflon (or other tape) to secure the connection of the LPG hose to your generator.

NOTE: If you would like to purchase other accessories for your dual-fuel generator, consult your local dealer of propane and propane accessories, I tell you what.

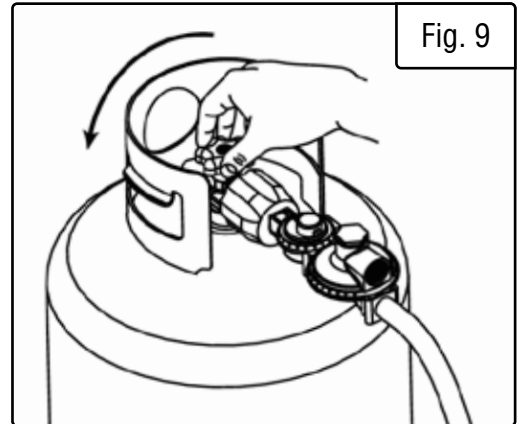

⚠ CAUTION! Always position the LPG cylinder so the connection between the tank and LPG inlet won't cause sharp bends or kinks in the hose.

⚠ WARNING! Risk of burns. Contact with liquid contents of cylinder will cause freeze burns to the skin. If liquid contents contacts skin or eyes, seek immediate medical attention.

⚠ WARNING! When transporting and storing, keep cylinder secured in an upright position with cylinder valve turned off. Keep cylinders ventilated and away from heat when in a vehicle.

NOTE: Make sure the generator can handle the load(s) you plan to connect. The generator can provide more power when running on gasoline than on LPG. Consult the specifications table on p. 3, as well as the "Calculating the Wattage of Your Device(s)" chart to ensure that your load(s) will not exceed the rated wattage for a particular fuel. See also "Switching Fuels" section for more information.

STEP 3 - CONNECT THE BATTERY

⚠ WARNING! Use only genuine WEN batteries with your generator (part no. 56380i-1304). Use of other batteries may induce premature product failure and could pose a safety risk.

ABOUT THE BATTERY

1. The lithium-ion battery supplied with your generator is only partially charged, in order to maximize its service life. The battery may not have enough charge to start the engine during its first use. If this is the case, connect the battery according to the instructions below, and start the generator using the recoil starter, according to the instructions below. The battery will receive charge when the generator is running.

2. Lithium-ion batteries are subject to a natural aging process. The battery must be replaced at the latest when its capacity falls to just 80% of its capacity when new. Weakened cells in an aged battery are no longer capable of meeting the high power requirements needed for the proper operation of your generator, and therefore pose a safety risk.

3. **DO NOT INCINERATE BATTERY.** Do not throw the battery into an open fire as this poses a risk of explosion. Do not ignite the battery or expose it to fire.

GENERATOR PREPARATION

ABOUT THE BATTERY (CONT.)

4. **AVOID DAMAGE AND SHOCKS.** Immediately replace batteries that have been dropped from a height of more than one meter (3 feet) or those that have been exposed to violent shocks, even if the housing of the battery appears to be undamaged. The battery cells inside the battery may have suffered serious damage. In such instances, please read the waste disposal information on p. 31 for proper battery disposal.

5. **DO NOT CRUSH, DROP OR DAMAGE BATTERY.** Do not use the battery if it has sustained a sharp blow, been dropped, run over or has been damaged in any way (e.g. pierced with a nail, hit with a hammer, stepped on, etc.).

6. **DO NOT DISASSEMBLE.** Incorrect reassembly may pose a serious risk of electric shock, fire or exposure to toxic battery chemicals. If the battery or charger are damaged, call WEN customer service at **1-800-232-1195** for assistance.

7. **DO NOT SHORT CIRCUIT.** Batteries will short circuit if a metal object makes a connection between the positive and negative contacts on the battery. Do not place the battery near anything that may cause a short circuit, such as paper clips, coins, keys, screws, nails and other metallic objects. A short-circuited battery poses a risk of fire and severe personal injury.

NOTE: The safe temperature range for charging the battery is 25°F – 104°F. The generator is shipped with the lithium-ion battery's negative (-) terminal disconnected to maximize safety. To start the generator using electric start, the battery must be connected.

To connect the battery:

1. Remove the black battery bracket by removing the two bolts that hold the battery bracket in place. Pull out the battery for easier access.

2. Pull back the protective cover from the red (+) lead near the battery.

3. Attach the red (+) lead to the positive (+) terminal on the battery, using the nut and bolt.

4. Repeat for the black (-) battery lead. Secure it to the negative (-) terminal on the battery.

STEP 4 - GROUNDING THE GENERATOR

To reduce the risk of electric shock and to maximize safety, the generator should be properly grounded.

1. Attach one end of the grounding wire to the grounding nut (Fig. 10). Tighten the nut to secure the grounding wire.

2. Connect the other end of the grounding wire to a copper, brass, or steel-grounding rod that is driven into the earth.

⚠ WARNING! Failure to properly ground the generator increases your risk of electric shock.

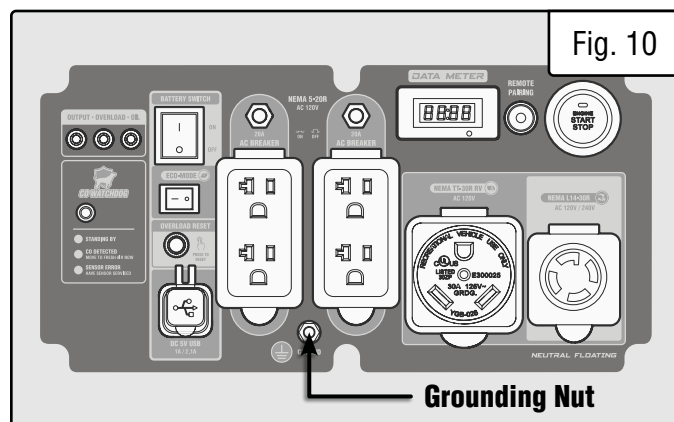

NOTE: Grounding wire and grounding rods are not included with the generator. A generally acceptable grounding wire is a **No. 12 AWG (American Wire Gauge) stranded copper wire**. Grounding codes can vary by location. Contact a local electrician to check the area codes.

STARTING THE GENERATOR

Before starting the generator, make sure you have read and performed the steps in the “Generator Preparation” section of this manual. If you are unsure about how to perform any of the steps in this manual please call **1-800-232-1195** (M-F 8-5 CST) for customer service.

DANGER: CARBON MONOXIDE

Using a generator indoors **CAN KILL YOU IN MINUTES**. Generator exhaust contains carbon monoxide (CO). This is a poison gas you cannot see or smell. If you can smell the generator exhaust, you are breathing CO. But even if you cannot smell the exhaust, you could be breathing CO.

NEVER use a generator inside homes, garages, crawl spaces, or other partially enclosed areas. Deadly levels of carbon monoxide can build up in these areas. Using a fan or opening windows and doors does NOT supply enough fresh air. **ONLY** use a generator outside and far away from windows, doors, and vents. These openings can pull in generator exhaust.

Even if you use a generator correctly, CO may leak into the home. **ALWAYS** use a battery-powered or battery-backup CO alarm in the home. If you start to feel sick, dizzy, or weak after the generator has been running, move to fresh air **RIGHT AWAY**. See a doctor. You may have carbon monoxide poisoning.

 **WARNING:** The exhaust from this product contains chemicals known to the State of California to cause cancer, birth defects, or other reproductive harm.

 **WARNING:** Do not operate generator near open flame or flammable materials. This generator may emit highly flammable and explosive gasoline vapors, which can cause severe burns or even death if ignited. A nearby open flame can lead to explosion even if it isn't directly in contact with gasoline. Do not smoke near the generator.

 **WARNING:** This generator produces powerful voltage, which can result in electrocution.

 **WARNING:** Do not use in rainy or wet conditions. Do not touch bare wires or receptacles (outlets). Do not allow children or non-qualified persons to operate.

 **WARNING:** Generator should only be connected to electrical devices, either directly or with an extension cord. **NEVER** connect to a building electrical system unless a qualified electrician has connected the generator to a transfer switch as a separately derived system. Such connections must comply with local electrical laws and codes. Failure to comply can create a back-feed, which may result in serious injury or death to utility workers.

To maximize safety, **ALWAYS** ground the generator before using it. Refer to "Step 3 - Ground The Generator."

Use a ground fault circuit interrupter (GFCI) in highly conductive areas such as metal decking or steel work. GFCIs are available in-line with some extension cords.

CAUTION! Disconnect all electrical loads from the generator before attempting to start it.

Follow the instructions on the next page to start your generator.

STARTING THE GENERATOR

BEFORE STARTING THE GENERATOR

1. Verify that the generator is outside on a dry, level surface. Allow at least two feet of clearance on all sides of the generator.
2. To maximize safety, check that the generator is properly grounded. Refer to "Step 4 - Ground The Generator."
3. Check that there is a sufficient level of oil in the crankcase. Add oil if necessary. Refer to "Step 1 - Add/Check Oil."
4. If using gasoline, make sure there is enough gasoline in the fuel tank. Add fuel if necessary (see "Add / check Fuel"). If using LPG, make sure there is enough propane in the tank, and that the tank and regulator hose are properly connected.
5. Make sure all electrical devices are unplugged from the generator during ignition. Otherwise it will be difficult for the engine to start.

STARTING THE GENERATOR (GASOLINE)

1. Turn the ECO-mode switch (Fig. 11 - 1) to OFF during starting.
2. Turn the battery switch (Fig. 11 - 2) to ON during starting.
3. Ensure that all electrical devices are disconnected from the generator.
4. Turn the fuel selector switch (Fig. 12 - 1) to the "GASOLINE" position (right).

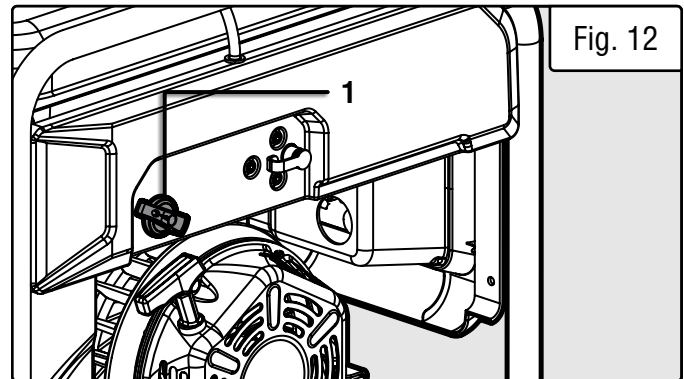
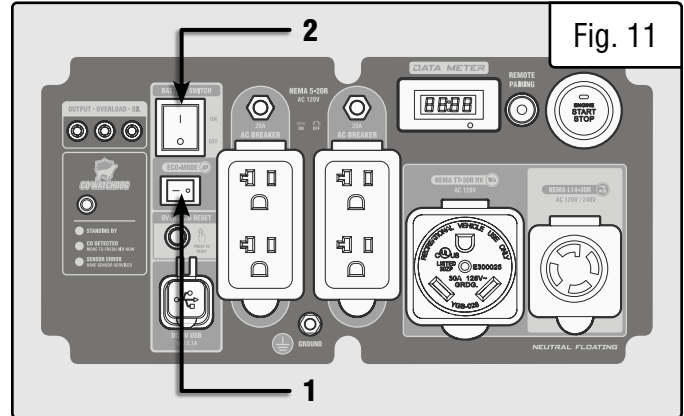

STARTING THE GENERATOR

STARTING THE GENERATOR (GASOLINE) CONT.

a. To start the engine using the electric starter:

- i. Make sure the battery is properly connected. If the battery is dead or not connected, the generator will not start.
- ii. Press the engine start/stop button (Fig. 13 - 1) once. Do not hold it down.
- iii. The engine start/stop button will begin flashing green, and will automatically adjust the choke and start the engine.
- iv. The generator will make 6 attempts to start the engine.

NOTE: If after 6 attempts the engine has not started, the engine start/stop button will flash red for 30 seconds. Check the troubleshooting steps on p. 40. If after checking all these steps the engine still will not start, contact WEN customer service for assistance.

b. To start the engine using the recoil starter:

- i. Move the choke lever (Fig. 14 - 1) left to the closed position. If the engine is warm, move the choke lever right to the open position.
- ii. Pull the recoil starter handle (Fig. 14 - 2) slowly until a slight resistance is felt, then pull quickly to start the engine. Return cord gently into the recoil starter. Never allow the cord to snap back.

NOTE: If the engine does not start after multiple attempts, please consult the troubleshooting guide on p. 40 before attempting to start the generator again. If problems persist, please contact WEN customer service (see front page of manual).

- iii. Slowly move the choke lever right to the open position.

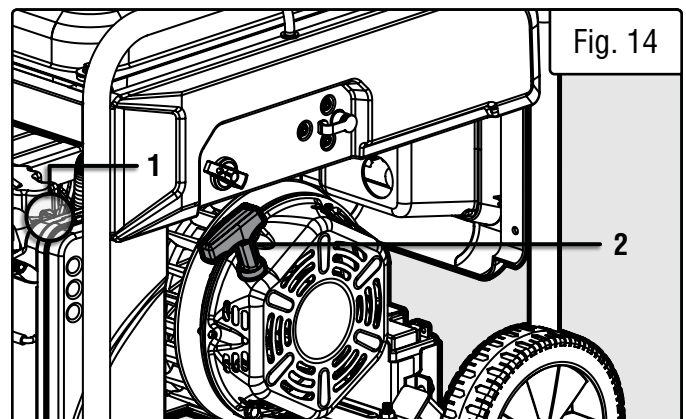
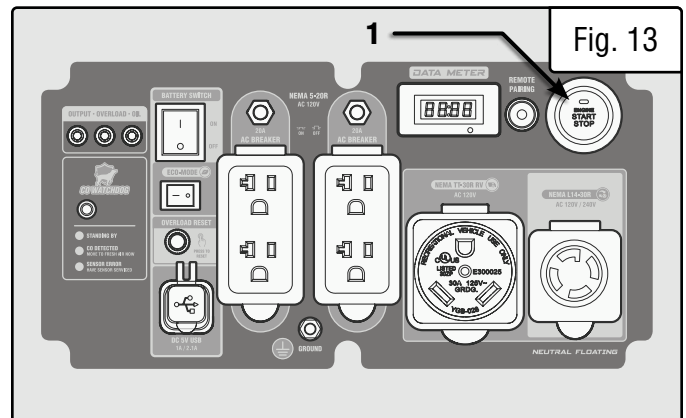

STARTING THE GENERATOR

STARTING THE GENERATOR (PROPANE)

1. Turn the ECO-mode switch (Fig. 15 - 1) to OFF during starting.
2. Turn the battery switch (Fig. 15 - 2) to ON during starting.
3. Ensure that all electrical devices are disconnected from the generator.
4. Turn the fuel selector switch (Fig. 16 - 1) to the “PROPANE” position (left).
5. Make sure the propane regulator and hose are securely attached to the propane cylinder and the propane inlet on the generator, and that the propane cylinder valve is turned ON.
6. Prime the engine. To do this, close the choke lever (Fig. 16 - 2) and pull the recoil starter (Fig. 16 - 3) 1 – 3 times.

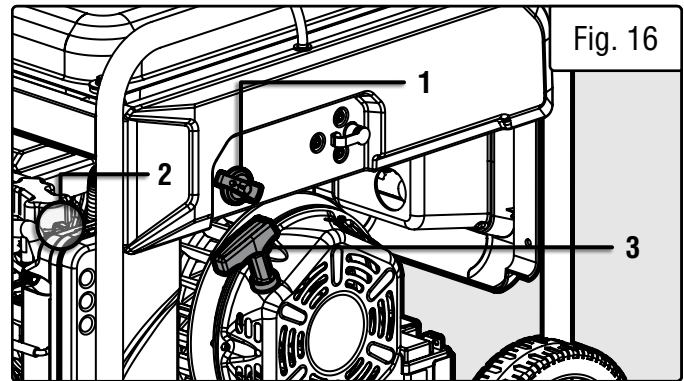
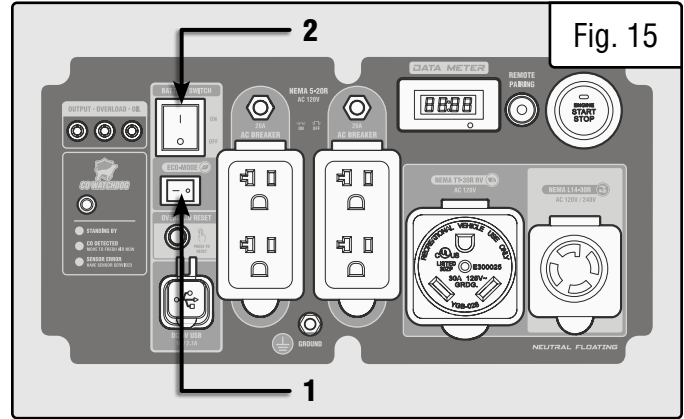

a. To start the engine using the electric starter:

- i. Make sure the battery is properly connected. If the battery is dead or not connected, the generator will not start.
- ii. Press the engine start/stop button (Fig. 13 - 1) once. Do not hold it down.
- iii. The engine start/stop button will begin flashing green, and will automatically adjust the choke and start the engine.
- iv. The generator will make 6 attempts to start the engine.

NOTE: If after 6 attempts the engine has not started, the engine start/stop button will flash red for 30 seconds. Check the troubleshooting steps on p. 40. If after checking all these steps the engine still will not start, contact WEN customer service for assistance.

b. To start the engine using the recoil starter:

- i. Move the choke lever (Fig. 16 - 2) left to the closed position. If the engine is warm, move the choke lever right to the open position.
- ii. Pull the recoil starter handle (Fig. 16 - 1) slowly until a slight resistance is felt, then pull quickly to start the engine. Return cord gently into the recoil starter. Never allow the cord to snap back.

NOTE: If the engine does not start after multiple attempts, please consult the troubleshooting guide on p. 40 before attempting to start the generator again. If problems persist, please contact WEN customer service (see front page of manual).

- iii. Slowly move the choke lever right to the open position.

7. After the engine has started, the engine start/stop button will continue flashing green for a few moments, then will stay solid green while the generator is running. The output indicator light (green) will light up, and the multi-meter will turn on.

8. Allow the generator to run for several minutes before attempting to connect any electrical devices. This allows the generator to stabilize its speed and temperature.

STARTING THE GENERATOR

USING THE REMOTE-START FUNCTION

Your generator comes with a remote-start function, enabling you to (what else?) start your generator remotely. Your generator and the included remote have been paired at the factory, and you can use the remote immediately.

NOTE: In order for the remote start function to work properly, you must be within 164 ft (50 m) of the generator. The remote's effective range may vary depending on the battery's state of charge, as well as miscellaneous environmental factors, radio interference, etc.

STARTING THE GENERATOR (REMOTE START)

1. Ensure that the battery switch (Fig. 15 - 2) on the panel is turned to ON. Ensure that the battery is connected and is not dead. Ensure that there is enough fuel, and the fuel selector switch is turned to the proper fuel source.
2. Ensure that all electrical devices are disconnected from the generator. Ensure that ECO-MODE (Fig. 15 - 1) is OFF.
3. Press the ON button on the remote control once. DO NOT hold the button down. The generator will wait for a moment, then automatically adjust the choke and start.

NOTE: The generator will make 6 attempts to start the engine automatically. If after 6 attempts the engine has not started, the engine start/stop button will flash red for 30 seconds. Check the troubleshooting steps on p. 40. If after checking all these steps the engine still will not start, contact WEN customer service for assistance.

4. Connect electrical devices.

NOTE: After the CO Watchdog system shuts down the generator, the generator cannot be restarted using remote start, for safety reasons. You must manually restart the generator using the recoil or electric starter. After doing this, the remote start can be used normally. See p. 31 for more information.

STOPPING THE GENERATOR (REMOTE START)

1. Turn off all electrical devices prior to unplugging them from the generator. Unplugging running devices can cause damage to the generator. Never start or stop the generator with electrical devices plugged in or turned on.
2. Let engine run at no-load for several minutes to stabilize its internal temperature. Ensure that ECO-mode is OFF.
3. Press the OFF button on the remote control once. Do NOT hold the button down. The generator will then shut down. The engine start/stop button will flash red and green simultaneously a few times to indicate that the generator was shut down remotely.
4. Once the engine shuts down, if the battery switch is still set to ON, the generator will enter standby mode. In standby mode, the generator can be started using the remote. The engine start/stop button will blink green once every 2 seconds to remind you that the generator is in standby mode.

NOTE: There is no limit to how long the generator will stay in standby mode, so if you forget to turn off the battery switch, it is possible that the battery will be drained the next time you try to use the generator. If you see the engine start/stop switch flashing green, always make sure the battery switch is turned OFF.

NOTE: During remote start and remote start, you may see the data meter display flicker slightly. This is normal and does not indicate a problem.

NOTE: If you purchase a new remote, you will need to pair the new remote with the generator. Follow instructions below. When replacing batteries in a remote, you should not need to pair the generator and remote again, but if you find that it does not work with new batteries, follow the instructions below to pair the generator and remote again.

STARTING THE GENERATOR

STORING THE REMOTE

We recommend clasping your remote to the loops on the USB cover on the panel for easy access.

PAIRING THE REMOTE AND GENERATOR

1. Make sure the battery is connected and charged, and the battery switch on the panel is set to ON.

2. Press the remote pairing button (Fig. 17 - 1) on the control panel once.

3. The engine start/stop button will flash red once.

4. Press the ON and OFF buttons on the remote simultaneously, within 5 seconds after seeing the engine start/stop button flash.

5. The engine start/stop button will flash red 4 times.

6. The generator will enter standby mode, and the engine start/stop button will flash green every 2 seconds.

NOTE: If in step 4, the ON and OFF buttons are not pressed within 5 seconds, the generator will enter its standby state. Start again from step 2 to pair the remote and generator.

UNPAIRING THE REMOTE AND GENERATOR

1. Make sure the battery is connected and charged, and the battery switch on the panel is set to ON.

2. Press the remote pairing button on the control panel 5 times quickly (within 5 seconds).

3. The engine start/stop button will flash red 4 times, and will clear all stored remote control data.

4. The generator will enter standby mode, and the engine start/stop button will flash green every 2 seconds.

REPLACING REMOTE BATTERIES

Your generator's remote comes with a CR2032 battery pre-installed and ready to use. However, the battery will eventually die and need to be replaced.

1. Use a fine-tipped Phillips-head screwdriver to remove the 3 screws on the back of the remote. Do not drop or lose the screws. Open the back of the remote and remove the CR2032 battery from the battery compartment.

2. Install a new CR2032 battery in the same orientation as you removed the old battery. (The + side, which should say "CR2032", faces the back of the remote.)

3. Replace the back of the remote and tighten the screws. Follow the instructions above to pair your remote with the generator (if necessary).

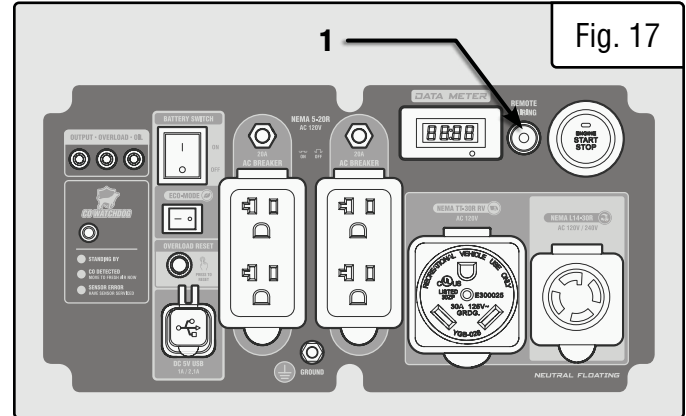

STARTING THE GENERATOR

STANDBY MODE

Once the generator is shut down, the generator's remote control function will stay in standby mode while the battery switch is ON. In standby mode, the generator can be started using the remote. The engine start/stop button will blink green once every 2 seconds to remind you that the generator is in standby mode.

NOTE: There is no limit to how long the generator will stay in standby mode, so if you forget to turn off the battery switch, it is possible that the battery will be drained the next time you try to use the generator. If you see the engine start/stop switch flashing green, always make sure the battery switch is turned OFF.

PAIRING MULTIPLE REMOTES

You can pair up to 15 remotes at a time with your generator. Remotes (**part no. DF875iX-1432**) can be purchased from **wenproducts.com**. To pair a new remote with your generator, follow instructions above in "Pairing the Remote and the Generator". You can also pair one remote with as many generators as you like.

NOTE: If you have multiple remotes paired with your generator and you unpair one remote, you will also unpair the other remotes simultaneously. You will need to pair the other remotes with the generator again before they can be used. If at any point you have questions, problems, or concerns about the remote start function, consult the Troubleshooting guide or contact customer service at **1-800-232-1195**.

USING THE GENERATOR

CALCULATING THE WATTAGE OF YOUR DEVICE(S)

Connect electrical devices running on AC current according to their wattage requirements. Calculate the total running wattage and starting wattage of the device(s) you wish to connect, and **MAKE SURE** that they are within the capacity of your generator and the capacity of each individual outlet.

Generator Wattage Capacity	GENERATOR RUNNING (RATED) WATTS	GENERATOR STARTING (SURGE) WATTS
	GAS: 7000W LPG: 6300W	GAS: 8750W LPG: 7800W
	<p>What this means: The generator can produce a maximum of 7000W (gas) or 6300W (LPG) on a continuous basis to supply ongoing power to your electronic devices.</p> <p>NOTE: Also check the rated amperage for each outlet and make sure not to overload the individual outlets.</p>	<p>What this means: Some devices such as box fans require short bursts of extra power in addition to the rated wattage listed by the device to start their motors.</p> <p>The generator can produce a maximum wattage of 8750W (gas) or 7800W (LPG) for a short period of time (seconds) to cover the extra starting power required by your electronic devices.</p>
Electronic Device Wattage Calculation	<p>Find the wattage information of each device you plan to connect. The information should be listed on the device or in its instruction manual, or you may refer to Table 2 - Estimated Wattages of Common Electrical Appliances.</p> <p>The wattage can be calculated using this equation: Watts = Volts x Amperes</p>	
	<p>To calculate the total running watts of your devices:</p> <p>+ Add up the running wattages of all the device(s) you plan to connect.</p> <p>= The total running (rated) wattage.</p> <p>This wattage should NOT exceed the running wattage of 7000W (gas) or 6300W (LPG).</p> <p>It is recommended to maintain a load at or below 6300W (gas) or 5670W (LPG) (90% of the rated output) to ensure steady voltage output and to prolong the generator's lifespan.</p>	<p>To calculate the total starting watts of your devices:</p> <p>+ Add up the total running wattage of all the device(s) you plan to connect.</p> <p>+ Add the single highest ADDITIONAL starting wattage out of the device(s) you plan to connect.</p> <p>= The total starting (surge) wattage.</p> <p>This wattage should NOT exceed the starting wattage of 8750W (gas) or 7800W (LPG).</p>
	<p>If any of either of the total calculated running watts or starting watts is higher than the capacity of your generator, adjust the load until both wattage requirements are met. Otherwise you will overload the generator, and cause damage to the engine and your electrical device(s).</p>	

Table 1 - How to Calculate Wattages

USING THE GENERATOR

CALCULATING THE WATTAGE OF YOUR DEVICE(S) - CONTINUED

The chart below serves as a reference for the estimated wattage requirements of common electrical devices. However, do not solely rely on this chart - all electronics and appliances are built differently. Always check the wattage listed on the electrical device before consulting this chart.

Tool or Appliance	Rated (Running) Watts	Surge (Starting) Watts
Hot Plate	2500	0
Saw - Radial Arm	2000	2000
Electric Stove (Each Element)	1500-2800	0
Saw - Circular	1500	1500
Air Compressor (1 HP)	1500	3000
Window Air Conditioner	1200	1800
Saw - Miter	1200	1200
Microwave	1000	0
Well Water Pump	1000	1000
Sump Pump	800	1200
Refrigerator Freezer	800	1200
Furnace Blower	800	1300
Computer	800	0
Electric Drill	600	900
Television	500	0
Deep Freezer	500	500
Garage Door Opener	480	0
Stereo	400	0
Box Fan	300	600
Clock Radio	300	0
Security System	180	0
DVD Player / VCR	100	0
Common Light Bulb	75	0

Table 2 - Estimated Wattages of Common Electrical Appliances

NOTE: Become familiar with the functions and capacity of each component on the control panel before connecting electrical devices. See page 11 for more information about the components of the control panel. Do not overload generator or individual panel receptacles. Do not connect 50Hz or 3-phase loads to the generator.

USING THE GENERATOR

CONNECTING ELECTRICAL DEVICES

1. Before connecting electrical devices, allow the generator to run for a few minutes to stabilize the speed and voltage output.
2. Select the device with the highest wattage, and make sure it is turned off. Plug the device into the matching generator outlet and then turn the device on. Allow the engine to stabilize.
3. Repeat step 2 to plug in each additional device. Do not attempt to plug in or start multiple devices at the same time.

NOTE: You may use the 120V and 240V outlets at the same time. This generator uses two windings to supply power. One winding powers the 5-20R outlets and one leg of the L14-30R outlet. The other winding powers the TT-30R outlet and the other leg of the L14-30R outlet. Consult the wiring diagram on p. 41 for more details.

ECO-MODE SWITCH

This generator is equipped with an Eco-Mode Idle Control Switch. Engaging this switch allows the system to regulate the engine speed and automatically adjust its fuel consumption to match the required load. When the electrical load changes, the generator engine will automatically speed up and slow down as needed. This reduces fuel consumption and noise levels, while extending runtime and engine's lifespan.

Keep this switch engaged **ONLY** when the power load requirement is less than 5250W (gas) or 4725W (LPG) (75% of the rated watts). Do not engage the Eco-Mode Switch when the total load is more than 5250W (gas) or 4725W (LPG). The generator engine must run at full speed to supply power for anything over 5250W (gas) or 4725W (LPG).

CIRCUIT BREAKER

The circuit breakers will activate when the load on the outlet exceeds the breaker's rating. When the circuit breaker activates, turn off and disconnect the device from its respective outlet, and press the circuit breaker to reset.

IN CASE OF OVERLOAD

If your generator becomes overloaded from too much drawn wattage, the overload light (red) on the control panel will light up. Follow the instructions below when an overload occurs:

- When you've overloaded the generator, the overload light will stay on and the overload reset button will activate to cut off the output in 3 to 16 seconds, depending on the load. Reduce the load by turning off and disconnecting your electrical device(s) until the overload light turns off. Wait about five minutes and then press the activated reset button to reset the circuit. If no power is produced after resetting, turn off and disconnect all electrical devices and restart your generator.
- The pattern in which the overload light blinks gives diagnostic information about the problem. Refer to the chart on the next page.

USING THE GENERATOR

LIGHT		MEANING	RESOLUTION
GREEN (POWER INDICATOR)	RED (OVERLOAD)		
ON	OFF	Generator output is normal.	No action needed.
OFF	Flashes 1x, repeating every 3 sec	Voltage at alternator is too low. No electrical output.	Check for loose connections. Call 1-800-232-1195 for assistance.
OFF	Flashes 2x, repeating every 3 sec	Engine speed is too low. No electrical output.	Check carburetor and stepper motor. Ensure Eco-Mode is OFF. Have generator serviced; call 1-800-232-1195 for assistance.
OFF	Flashes 3x, repeating every 3 sec	Inverter temperature is too high. No electrical output.	Turn generator off and let it cool down fully (1 – 2 hours) before restarting.
OFF	Flashes 5x, repeating every 3 sec	Voltage at alternator is too high. No electrical output.	Have generator serviced; call 1-800-232-1195 for assistance.
OFF	Flashes 6x, repeating every 3 sec	Generator has exceeded rated output and cut off power to protect itself. No electrical output.	Turn OFF and disconnect loads. Press RESET button on panel. Reduce load on generator.

SOME NOTES ABOUT POWER CORDS

Refer to the following chart in determining the necessary gauge extension cord for each of your devices. Round up to the higher amperage in the chart to maximize safety.

Device Requirements			Max. Cord Length (ft) by Wire Gauge				
Amps	Watts (120V)	Watts (240V)	#8 wire	#10 wire	#12 wire	#14 wire	#16 wire
2.5	300	600	NR	NR	NR	375	250
5	600	1200	NR	NR	300	200	125
7.5	900	1800	NR	350	200	125	100
10	1200	2400	NR	250	150	100	50
15	1800	3600	NR	150	100	65	NR
20	2400	4800	175	125	75	50	NR
25	3000	6000	150	100	60	NR	NR
30	3600	7200	125	65	NR	NR	NR
40	4800	9600	90	NR	NR	NR	NR

*NR = Not Recommended

Table 3 - Power Cord Requirement Guide

⚠ WARNING! Generator should **only** be connected to electrical devices, either directly or with an extension cord. NEVER CONNECT TO A BUILDING ELECTRICAL SYSTEM unless a qualified electrician has connected the generator to a transfer switch as a separately derived system. Such connections must comply with local electrical laws and codes. Failure to comply can create a back-feed, which may result in serious injury or death.

NOTE: For power outages, permanently installed, stationary generators are better suited for providing backup power to your home. Even a properly connected portable generator can become overloaded. This may result in overheating or stressing the machine's components, possibly leading to generator failure.

USING THE GENERATOR

SWITCHING FUELS

To maximize your generator's lifespan, we recommend removing all loads from the generator before switching between gasoline and LPG. If this is not possible, reduce loads as much as possible in order to ensure a smooth switch. Your generator is rated to handle a higher load when running on gasoline than on LPG, so keep this in mind when planning your fuel usage. To switch fuels:

1. Make sure you have enough gasoline or propane. If switching to propane, make sure the propane regulator and hose are securely attached to the propane cylinder and the propane inlet on the generator, and that the propane cylinder valve is turned ON.
2. Turn the fuel selector switch (Fig. 18 - 1) to the desired fuel source.

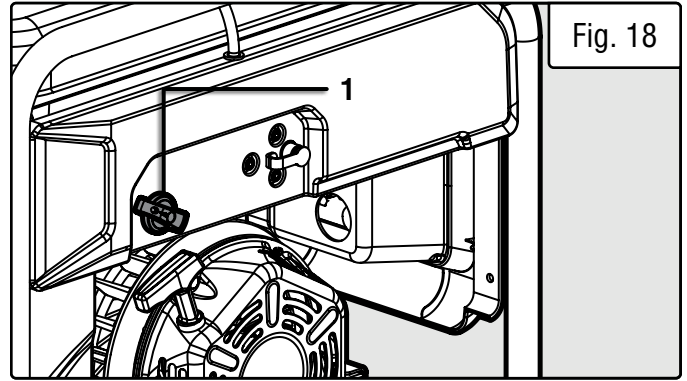

Fig. 18

USING THE GENERATOR

CO SENSOR INFORMATION

The CO Watchdog carbon monoxide monitoring system (Fig. 19 - 1) measures the accumulation of poisonous CO gas while the generator is running. If the level of CO gas gets too high, the CO Watchdog system will automatically shut down the generator. **This system is not a substitute for an indoor CO alarm.**

Whenever the CO Watchdog system shuts down the generator, the LED on the generator control panel (Fig. 19 - 1) will **blink red** for at least 5 minutes after the generator is shut down. **If you notice that the LED is blinking red, vacate the area immediately.** Go to an open, outdoor area. Ventilate the area around the generator thoroughly before returning. Let the generator stay shut down for a few minutes before restarting the engine. This should allow carbon monoxide to dissipate from the area. If you restart the generator and the CO Watchdog detects that CO levels are still too high, it will shut down the generator again. If CO levels are low enough, the generator will run normally.

Ensure that the generator is located in an open outdoor area, with the exhaust pointing away from occupied structures, and pointing away from the prevailing winds, such that those winds do not blow engine exhaust towards the sensor module. If anyone experiences dizziness, headaches, nausea, fatigue, or other symptoms of CO poisoning, get to fresh air immediately and seek the attention of a qualified medical professional. Follow all other directions in this manual regarding the connection and disconnection of electrical devices when starting or shutting down the generator.

When starting the generator, the CO Watchdog LED on the panel may flash. This indicates that the system is running a self-test procedure, and does not indicate a problem.

If the CO Watchdog LED on the panel is **yellow**, a system error has occurred, or the CO sensor has reached the end of its life. Contact WEN customer service (**1-800-232-1195**, M – F 8 – 5 CST, or techsupport@wenproducts.com) for assistance.

When operating your generator, please note the following:

- The CO Watchdog does not discriminate in its input; any source of carbon monoxide in the area around the generator could cause it to activate. If the CO Watchdog LED is blinking red, safety measures should be taken immediately.
- Tampering with, disconnecting, or bypassing the CO sensor could cause hazardous conditions, including but not necessarily limited to injury or death, and will void your warranty. The generator will not run with the CO sensor disconnected or bypassed, or if the CO sensor indicates an error.
- The CO sensor has a lifetime of about 7 years, and is capable of monitoring its lifetime. If your generator shows an error light several years after purchase, it may be time to replace the CO sensor. Contact WEN customer service for assistance.

NOTE: After the CO Watchdog system shuts down the generator, the generator cannot be restarted using remote start, for safety reasons. You must manually restart the generator using the recoil or electric starter. After doing this, the remote start can be used normally.

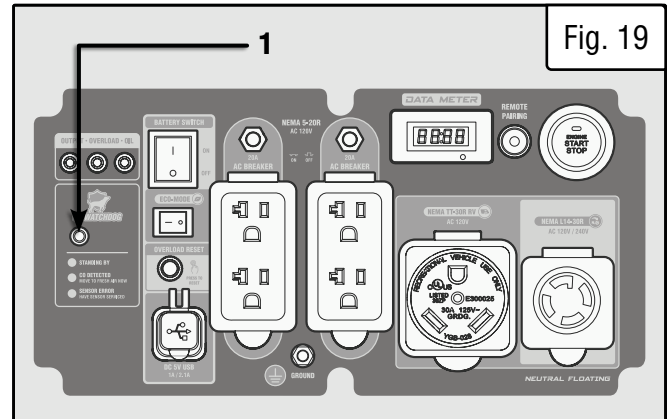

NOTE: If the generator is oriented so that the engine exhaust is blown towards the CO sensor, the generator may shut down.

SHUTTING OFF THE GENERATOR

⚠ CAUTION! Unplugging running devices can cause damage to the generator. Never stop the engine with electrical devices connected and running.

⚠ WARNING! Allow the generator to cool down before touching areas that become hot during use.

CAUTION! Allowing gasoline to sit in the fuel tank for long periods of time can make it difficult to start the generator in the future. Never store the generator for extended periods of time (over 2 months) with fuel in the fuel tank. Refer to "Storing The Generator."

SHUTTING OFF THE GENERATOR

1. Turn off all electrical devices prior to unplugging them from the generator. Unplugging running devices can cause damage to the generator. Never start or stop the generator with electrical devices plugged in or turned on.

2. Let the engine run at no-load for several minutes to stabilize its internal temperature.

3. You can shut down the generator in one of several ways:

i. Press the engine start/stop button.

ii. Turn the battery switch to OFF.

iii. Position the fuel selector switch halfway between "GASOLINE" and "PROPANE".

iv. Press OFF on the remote to shut down the generator remotely.

4. Once the engine shuts down, if the battery switch is still set to ON, the generator will enter standby mode. In standby mode, the generator can be started using the remote. The engine start/stop button will blink green once every 2 seconds to remind you that the generator is in standby mode.

NOTE: There is no limit to how long the generator will stay in standby mode, so if you forget to turn off the battery switch, it is possible that the battery will be drained the next time you try to use the generator. If you see the engine start/stop switch flashing green, always make sure the battery switch is turned OFF.

5. Turn off the propane cylinder valve (if applicable). Disconnect the propane regulator and hose from the propane cylinder and the propane inlet on the generator

6. Drain the carburetor. Refer to "DRAINING THE CARBURETOR" section. This step is only applicable if you have used gasoline.

IMPORTANT: Always ensure that the battery switch is in the OFF position when the generator is not in use.

MAINTENANCE

RECOMMENDED MAINTENANCE SCHEDULE

Proper routine maintenance of the generator will help prolong the life of the machine. Please perform maintenance checks and operations according to the maintenance schedule below, Table 4. If there are any questions about the maintenance procedures listed in this manual, please contact customer service at **1-800-232-1195** (M-F 8-5 CST), or email techsupport@wenproducts.com.

⚠ WARNING! Never perform maintenance operations while the generator is running. Before maintaining or servicing the generator, turn OFF the generator, disconnect all devices and allow the generator to cool down.

Recommended Maintenance Schedule		Every 8 Hours or Daily	Every 25 Hours	Every 3 Months or 50 Hours	Every 6 Months or 100 Hours	Before Storage	As Necessary
Engine Oil	Check Level	X					
	Replace		X*				X
Air Filter	Check			X*			
	Clean			X*			
Spark Plug	Check/Clean/Regap				X		
	Change				X		X
Fuel	Check Level	X					
	Drain					X	X
Carburetor	Drain	X					X
Spark Arrestor	Check/Clean				X		

* Clean/change more often under dusty conditions or operating under heavy load.

Table 4 - Recommended Maintenance Schedule

IMPORTANT GENERATOR MAINTENANCE TIPS:

- Drain your carburetor after each use and before storage to prevent it from clogging.
- Do not store the generator with fuel inside the tank for more than 2 months - the fuel will go bad.
- Run the generator for 20 to 30 minutes every month to maximize its lifespan.

NOTE: Failure to properly maintain the generator will void the warranty.

CLEANING YOUR GENERATOR

Keep the generator clean to prevent improper operation or machine damage from dirt and debris. Inspect all ventilation openings on the generator. These openings must be kept clean and unobstructed.

If the generator becomes dirty, use a damp cloth to wipe exterior surfaces. Use a soft bristle brush to loosen dirt and oil and use a vacuum to pick up loose dirt. Use low pressure air (not to exceed 25 PSI) to blow away dirt.

⚠ WARNING! Never clean the generator when it is running! Never clean with a bucket of water or a hose. Water can get inside the working parts of the generator and cause corrosion or a short circuit.

CHECKING / ADDING OIL

Check the oil level before each use and every 8 hours of operation (refer to Table 4). The oil capacity of the generator engine is **37.2 fl oz (1.1 L)**. Add oil when the oil level is low. For the proper type and weight of oil refer to Fig. 2. This is a critical step for proper engine starting. The generator is equipped with a with low-oil shut down to protect it from running without oil.

To check the oil level and/or add oil refer to "Step 1 - Add/Check Oil."

DRAINING / CHANGING OIL

Change the oil according to the Recommended Maintenance Schedule in Table 4. Change the oil **more often** if operating under heavy load or high ambient temperatures. It is also necessary to drain the oil from the crankcase if it has become contaminated with water or dirt. Changing the oil when the engine is warm allows for more-complete drainage.

To change engine oil:

1. Prepare an approved oil-storage container underneath the oil drainage hose (Fig. 20 - 1) to catch oil as it drains.

NOTE: To avoid possible gasoline spills from the carburetor bowl, drain the carburetor before draining oil.

2. Remove the oil drainage hose from its harness behind the panel. Open the oil drainage valve by turning the lever, and allow oil to drain from the engine completely.

3. Close the oil drainage valve after the oil has drained.

NOTE: Never dispose of used engine oil in the trash or down a drain. Please call a local recycling center or auto garage to arrange proper oil disposal.

4. Unscrew the oil dipstick. Using a funnel or appropriate dispenser, add 37.2 fl oz of clean engine oil into the oil fill until you can see oil coming up the threads of the oil fill. Do not over fill.

5. Reinstall the oil dipstick and tighten it securely. Wipe clean any oil spillage.

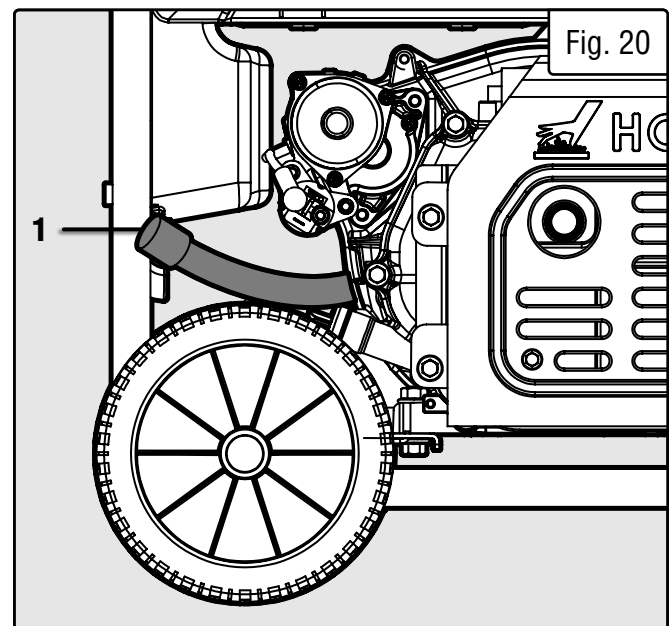

MAINTENANCE

DRAINING THE CARBURETOR

Drain the carburetor after every use and before storing the generator (refer to Table 4). Draining the carburetor can help prevent build-up and blockages caused by stagnant fuel inside of the carburetor.

1. Prepare an approved gasoline-storage container under the carburetor to collect the drained fuel. Close fuel valve.
2. The carburetor can be accessed from the backside of the generator between the engine and the air filter. To drain the carburetor, open up the carburetor drain screw (Fig. 21 - 1) with a Phillips-head screwdriver (not included) and drain out any gasoline that has built up inside.
3. Once the fuel has drained, close the drain screw.

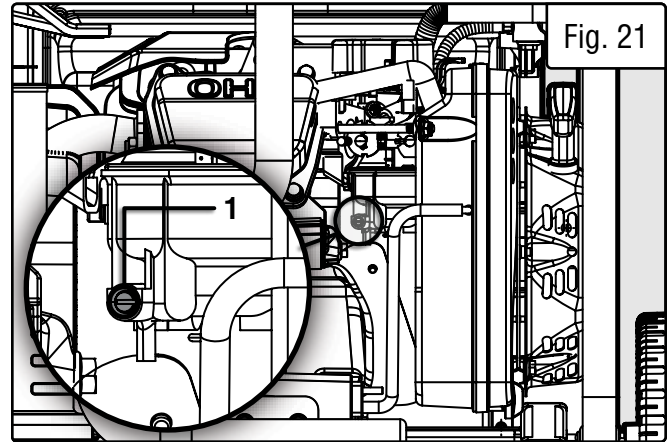

Fig. 21

NOTE: Make sure to drain your carburetor before storing the generator for long periods of time.

INSPECTING/CLEANING THE AIR FILTER

Inspect and clean the air filter every 50 hours of operation (refer to Table 4). Routine maintenance of the air filter helps maintain proper airflow to the carburetor. Occasionally check that the air filter is free of excessive dirt. Clean air filter more frequently in dirty or dusty conditions.

⚠ WARNING! Running the engine with a dirty, damaged or missing air filter element can result in danger to the operator and cause the engine to wear out prematurely.

1. Remove the air filter cover (Fig. 22 - 1) by unscrewing the cover lock knob (Fig. 22 - 2) at the bottom of the air filter cover.
2. Remove the foam, sponge-like air filter element from the casing. Wipe excessive oil and any dirt from inside of the air filter casing.
3. Check the foam, sponge-like air filter element.
 - a) **Good elements** can be washed in soapy water. Dry the element in clean cloth (do not twist it). Add a few drops of engine oil to the air filter element and spread it evenly. A small amount of oil left in the element is normal and necessary for the engine to work properly.
 - b) **Damaged elements** should be replaced with a new one. Replacement air filters can be purchased from wenproducts.com.
4. Reinstall the air filter element and air filter cover.

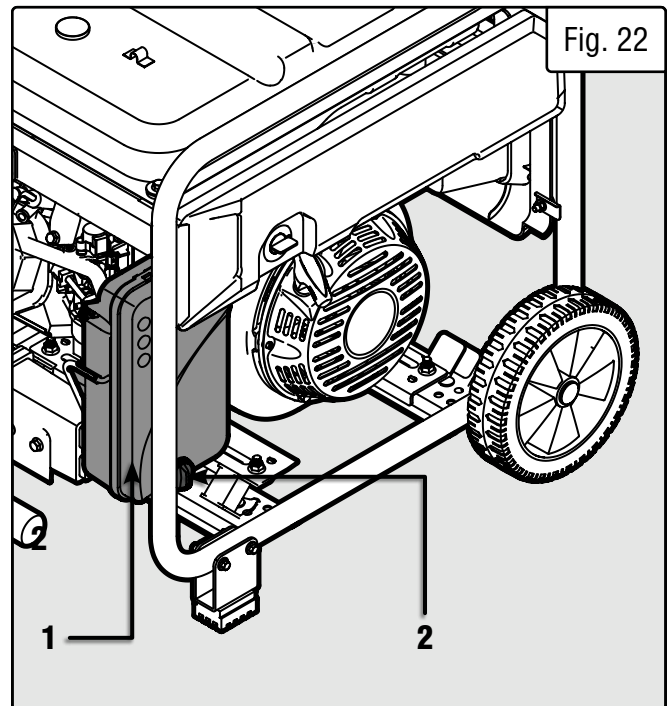

Fig. 22

MAINTENANCE

INSPECTING/CLEANING THE SPARK ARRESTOR

Inspect and clean the spark arrestor every 100 hours of operation (refer to Table 4). The spark arrestor is located outside the muffler, which gets very hot during operation. Allow the engine to cool completely before servicing the spark arrestor.

1. Remove the two bolts that secure the spark arrestor to the muffler. See Fig. 23.
2. Remove the spark arrestor screen.
3. Carefully clean and remove the carbon deposits from the spark arrestor screen with a wire brush. Replace the spark arrestor if it is damaged. Replacement spark arrestors can be purchased from **wenproducts.com**.
4. Reinstall the spark arrestor in the muffler and secure it in place with the screws.

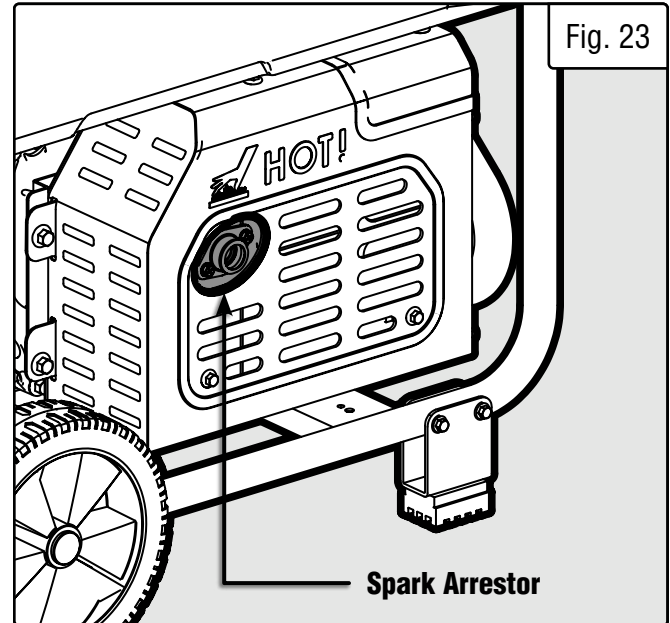

SPARK PLUG MAINTENANCE

Inspect and change the spark plug every 100 hours of operation (refer to Table 4). The spark plug is important for proper engine operation. Check the spark plug regularly to maintain proper engine operation. A good spark plug should be intact, free of deposits, and properly gapped.

1. Gently pull on the spark plug boot to remove it. Be careful not to tear insulation or wire.
2. Use the included spark plug wrench (slide the handle into the hole on the wrench) to unscrew the spark plug from the engine. Remove the spark plug from the engine. **TIP:** There is limited space for the wrench to turn. Use both rows of holes in the spark plug wrench to gain leverage to loosen the plug.
3. Visually inspect the spark plug. If it is cracked or chipped, or if the electrodes are worn or burned, discard it and replace with a new spark plug. We recommend replacing it with an **F7RTC (NGK BPR7ES)** spark plug. These can be purchased from **wenproducts.com** (part no. **DF875iX-0215**).
4. If re-using the spark plug, use a wire brush to clean any dirt from around the spark plug base, then re-gap the spark plug.

Instructions continue on the next page.

MAINTENANCE

5. Measure the plug gap with a spark plug gap gauge. The gap should be **0.7 to 0.8 mm (0.028-0.031 in)**. Carefully adjust the gap if necessary. See Fig. 24.

6. Screw the spark plug back into the spark plug hole using the spark plug wrench. Do not over-tighten spark plug. Recommended tightening of the spark plug is **½ to ¾ of a turn** (15 ft-lb torque/20.33 Nm) after the spark plug gasket contacts the spark plug hole.

7. Reinstall the spark plug boot over the spark plug.

DRAINING THE FUEL TANK

Drain and clean the fuel tank each year, or before storing the generator for longer than two months.

1. Prepare an approved gasoline-storage container to collect the drained fuel. Place it near the fuel selector switch (Fig. 25 - 1).

2. Turn the fuel selector switch to the PROPANE position.

3. Locate the fuel line between the fuel selector switch and the carburetor. Disconnect the fuel line from the fuel selector switch.

NOTE: A small amount of fuel may leak from the fuel line during removal.

4. Place a funnel below the fuel selector switch opening, and direct the other end of the funnel over the prepared container.

5. Turn the fuel selector switch to the GASOLINE position to start draining the fuel from the fuel selector switch opening.
NOTE: The draining process may take a few hours, depending on the amount of fuel in your gas tank.

6. Once the fuel is completely drained, turn the fuel selector switch to the PROPANE position.

7. Start and run the engine until the fuel runs out.

8. Drain the carburetor. Refer to "Draining The Carburetor."

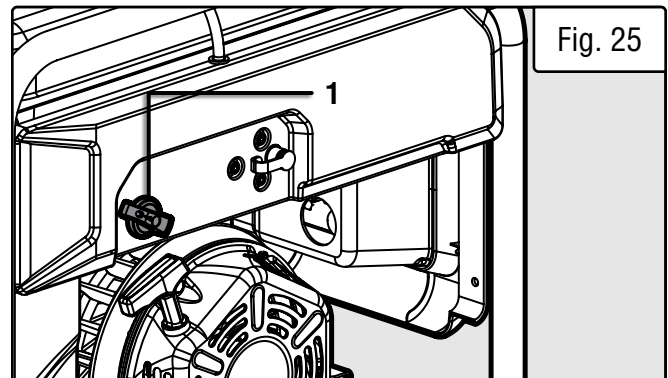
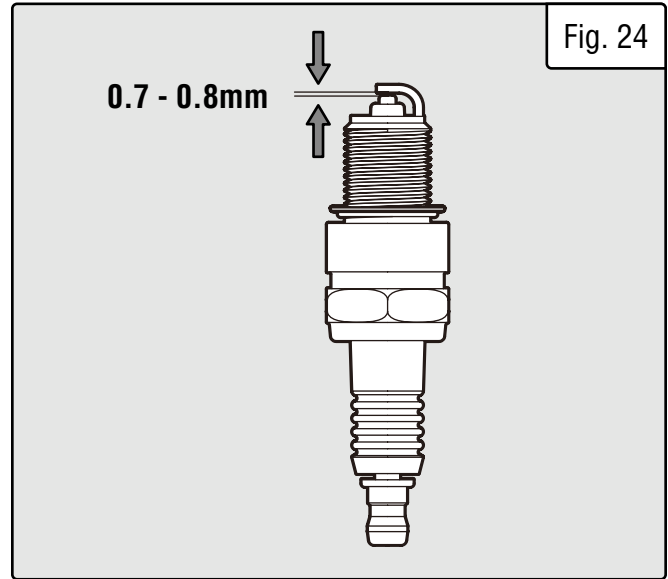

CAUTION! Store the emptied gasoline in a suitable place. Never store fuel for more than 2 months.

MAINTENANCE

BATTERY MAINTENANCE/STORAGE

The battery will receive charge when the engine is running. Remember to run the generator once a month for 20-30 minutes to charge the battery. A charged battery will allow you to start the generator during your next time of need.

⚠ IMPORTANT! If you do not plan to use the generator for a long period of time, we recommend DISCONNECTING the negative battery cable from the battery to protect the battery from losing charge. After disconnecting the cable, cover the free end with an insulator such as electrical tape. You may also choose to use a trickle charger (not included) to maintain battery charge.

Lithium-ion batteries can be damaged or suffer a shortened lifespan if they are charged in very cold temperatures (below freezing). If you expect to store the generator in temperatures below 25°F (-5°C), we recommend removing the battery from the generator and storing it indoors. If using the generator in temperatures below 25°F (-5°C), we recommend running the generator for at least 15 minutes with the battery removed, or the negative (black) battery cable disconnected and covered with an insulator such as electrical tape, and then connecting the battery. This will allow the area around the generator to warm up, and will greatly reduce the chance of damage to the battery.

⚠ WARNING! It is best to store the battery indoors at room temperature. Do not store your battery outside in the winter, where temperatures may go below 25°F (-5°C), or in any location where temperatures may exceed 104°F (40°C), such as in direct sunlight or inside a vehicle or metal building during the summer.

NOTE: Always recycle used batteries in accordance with local laws and regulations. Contact your local solid waste collection site or recycling facility to obtain information on local recycling processes.

TRANSPORTATION & STORAGE

TRANSPORTING THE GENERATOR

To prevent fuel spillage when transporting, be sure to perform the following:

1. Tighten the fuel cap and turn the fuel valve to the OFF position.
2. Flip the engine switch to the STOP position.
3. Drain the fuel tank if possible. Refer to "Draining The Fuel Tank."
4. Keep the generator upright. Never place the generator on its side or upside down - doing so could damage the internal components of the generator and make it difficult to start.

 **WARNING!** Avoid direct sunlight inside a vehicle. If the generator is left in an enclosed vehicle for many hours, the high temperature could cause the fuel to vaporize and result in a possible explosion.

STORING THE GENERATOR

Shut off the generator and allow the unit to cool to room temperature before storing it. NEVER place any type of storage cover on the generator while it is still hot. Do not obstruct any ventilation openings.

Follow the procedures below for properly storing your generator. We highly recommend running your generator once a month for 20 to 30 minutes. Plug in a small load in to ensure there is proper power output.

TIP: Your WEN generator is compatible with **WEN 56409** and **WEN GNC875** Generator Covers (not included). They are available for purchase at wenproducts.com.

For Short Periods (30 to 60 Days):

- Drain the carburetor. Refer to "Draining The Carburetor."
- **Add fuel stabilizer:** Follow suggested portions and instructions of your preferred stabilizer. Run engine for 15 to 20 minutes, allowing fuel stabilizer to mix with the gasoline and circulate through the carburetor, and then top off with fuel. Filling the fuel tank full reduces the amount of air in the tank and helps fight deterioration of fuel.

For Extended Periods (Over 60 Days):

- Disconnect the negative lead from the battery. Refer to "Battery Maintenance/Storage."
- Drain fuel tank and carburetor. Refer to "Draining The Fuel Tank" and "Draining The Carburetor."
- Never store generator with fuel in the tank for more than two months.
- Change engine oil. Refer to "Checking/Adding Oil."

 **WARNING!** Store the generator upright in a cool and dry location, away from sources of heat, open flames, sparks or pilot lights.

PRODUCT DISPOSAL

Do not dispose of used generator or parts with your household waste. This product contains electrical or electronic components that should be recycled. Please take this product to your local recycling facility for responsible disposal to minimize its environmental impact.

Do not dispose of used oil or fuel in the trash or down a drain. Please contact your local recycling center or auto garage to arrange proper oil/fuel disposal.



Please recycle the packaging and electronic components where facilities exist. Please contact your local auto garage or recycling facility to properly dispose of oil/fuel.

TROUBLESHOOTING GUIDE

⚠ WARNING! Stop using the generator immediately if any of the following problems occur or risk serious personal injury. If you have any questions, please contact customer service at **1-800-232-1195** (M-F 8-5 CST), or email **techsupport@wenproducts.com**.

PROBLEM	POSSIBLE CAUSE	SOLUTION
Engine will not start.	1. Fuel selector switch is in wrong position.	1. Set fuel selector switch to match fuel being used.
	2. Battery switch is set to OFF (0).	2. Set battery switch to ON (1).
	3. Engine has not been primed (LPG only).	3. Prime the engine.
	4. Battery is dead.	4. Electric and remote start will not work if battery is out of power. Start generator using the recoil start to charge the battery.
	5. Battery is too cold.	5. Electric start may be difficult if the battery is too cold. Store the generator or battery in a warmer location. Start generator using recoil start to warm up area around generator.
	6. Oil is low.	6. Add oil.
	7. Engine is out of fuel.	7. Add fuel.
	8. Engine is filled with contaminated or old fuel.	8. Drain fuel in the tank and carburetor. Replace with fresh fuel. Clean carburetor if necessary.
	9. Spark plug boot is disconnected.	9. Replace spark plug boot on spark plug.
	10. Spark plug is dirty or broken.	10. Clean or replace spark plug. Re-gap if needed.
	11. Propane tank is turned OFF.	11. Dang it, Bobby, I told you to turn that thing on!
	12. Carburetor is air locked.	12. Set fuel selector switch to "PROPANE". Remove fuel solenoid valve and bolt from bottom of the carburetor. Take off the carburetor bowl to allow it to reset. Replace carburetor bowl and reinstall the bolt, then reinstall the solenoid valve.
	13. Onboard propane regulator is stuck.	13. Turn OFF propane tank. Disconnect hose from propane fitting. Contact WEN customer service for assistance.
	14. CO levels are too high.	14. Move the generator to an open area with fresh air. Wait a few minutes for the CO buildup to dissipate.
	15. CO sensor is disconnected.	15. Make sure CO sensor is connected.
	16. Ghost in the generator.	16. Persuade ghost to leave. Consult Bill Murray if needed.
Engine will not start (remote start).	1. Remote is out of range.	1. Move closer to generator and point the remote at the generator.
	2. Remote battery is dead.	2. Replace the remote battery (CR2032).
	3. Generator and remote are not paired.	3. Pair remote and generator. See "PAIRING THE REMOTE AND GENERATOR" section.
	4. Other cause (see "engine will not start" above).	4. Resolve other cause.
Engine runs, but there is no electrical output.	1. Circuit breaker has been tripped due to overload, or the inverter has cut off power to protect itself.	1. Turn off and unplug electrical device(s). Wait 5 minutes, then press the circuit breaker button (or reset button) to reset. Check the total wattage of the devices and reduce the load if it exceeds the capacity of the generator. Then plug the loads back in one by one.
	2. Bad connecting cords/wires.	2. Check the power cords and extension cords. Do not use if any cord is damaged. Replace damaged cords immediately.
	3. Bad electrical device connected to the generator.	3. Try connecting a different device.
	4. Internal generator problem.	4. Consult Table 2 for troubleshooting the overload light.

TROUBLESHOOTING GUIDE

⚠ WARNING! Stop using the generator immediately if any of the following problems occur or risk serious personal injury. If you have any questions, please contact customer service at **1-800-232-1195** (M-F 8-5 CST), or email **techsupport@wenproducts.com**.

PROBLEM	POSSIBLE CAUSE	SOLUTION
Generator runs but does not support all electrical devices connected.	1. Generator is overloaded.	1. Turn off and unplug electrical device(s). Wait 5 minutes, then press the circuit breaker button (or reset button) to reset. Check the total wattage of the devices and reduce the load if it exceeds the capacity of the generator. Then plug the loads back in one by one.
	2. Short circuit in one of the devices.	2. Try disconnecting any faulty or short-circuited electrical loads.
	3. Air filter is dirty.	3. Clean or replace the air filter element. Refer to "INSPECTING/CLEANING THE AIR FILTER."
Engine is "hunting" during operation (engine RPM is fluctuating). NOTE: Turn off the generator and wait for it to cool down before performing the maintenance solutions.	1. Fuel isn't running through the fuel selector switch.	1. Check if the fuel is properly and consistently going through the fuel selector switch.
	2. Fuel level is low.	2. Check fuel level.
	3. The air filter is clogged.	3. Check for any blockage in the air filter. Check and clean the air filter as necessary.
	4. The muffler or spark arrester is blocked.	4. Check if the spark arrester is blocked. Clean with metal brush as necessary.
	5. There is gunk in the carburetor preventing a consistent fuel/air mixture.	5. Use "gunk remover" spray on the carburetor jets.

IMPORTANT: Repairs and replacements should only be performed by an authorized technician. Parts and accessories that wear down over the course of normal use are not covered by the two-year warranty.

WIRING DIAGRAM

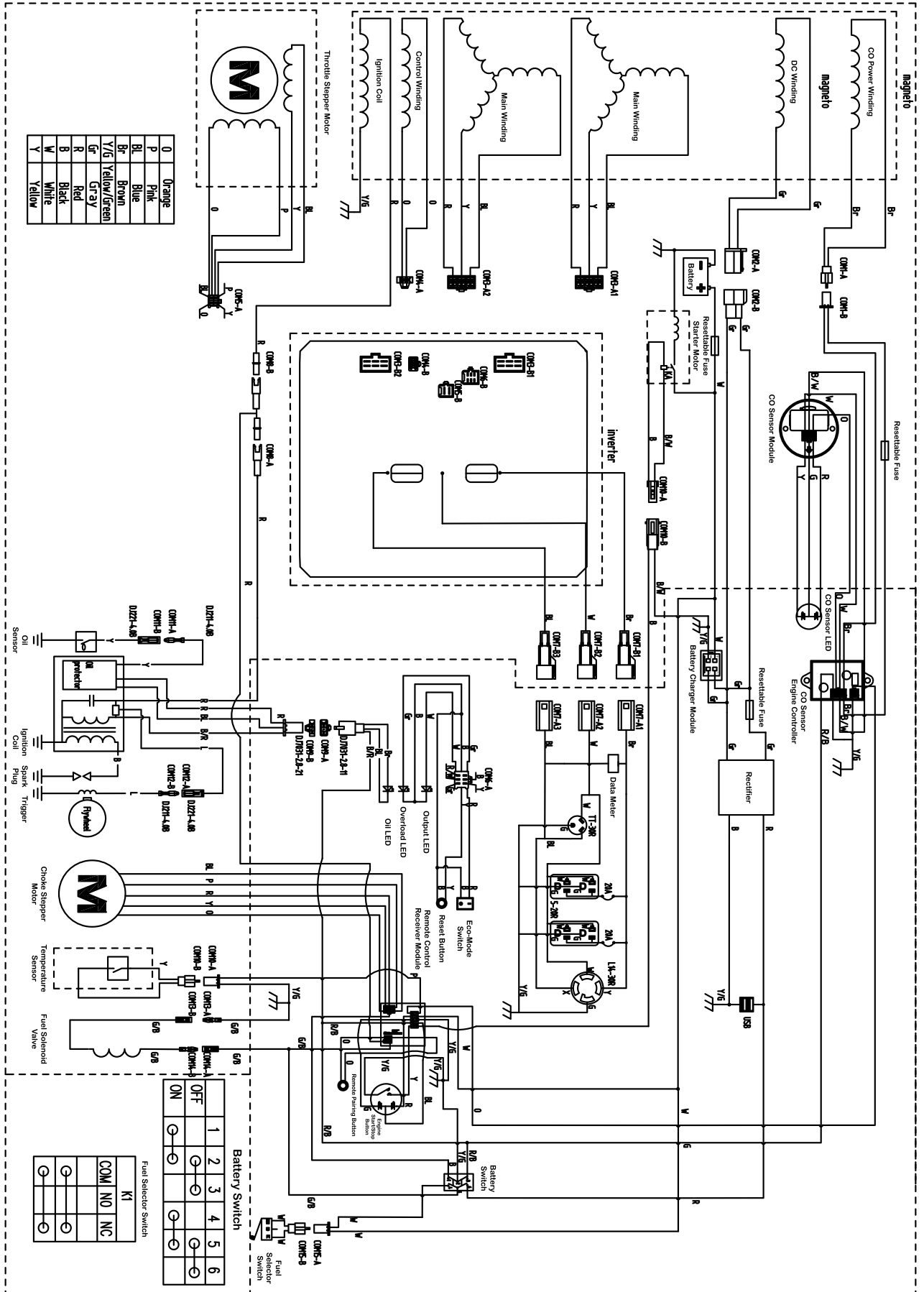

EXPLODED VIEW & PARTS LIST

NOTE: Replacement parts can be purchased from wenproducts.com, or by calling our customer service at **1-(800) 232-1195**, M-F 8-5 CST. Parts and accessories that wear down over the course of normal use are not covered by the two-year warranty. Not all parts may be available for purchase.

ASSEMBLY 1 - CRANKCASE

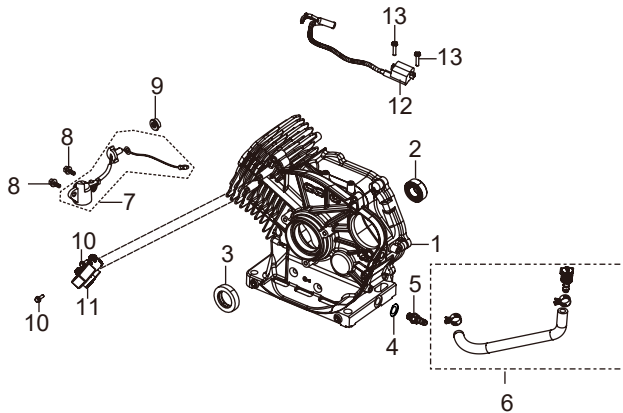

No.	Part No.	Description	Qty.
1-1	GN875i-0101	Crankcase	1
1-2	GN875i-0102	Bearing, 6202P6	1
1-3	GN875i-0103	Oil Seal	1
1-4	GN625i-0204	Flat Washer, 12mm	1
1-5	GN875i-0105	Oil Drain Hose Fitting	1
1-6	GN625i-0205	Oil Drain Hose	1
1-7	GN625i-0207	Engine Oil Sensor	1
1-8	GN625i-0208	Bolt, M6x16	2
1-9	GN875i-0109	Nut, M10	1
1-10	GN400i-0910	Bolt, M5x16	2
1-11	DF875iX-0111	Trigger	1
1-12	DF875iX-0112	Ignition Coil	1
1-13	GN400i-0111	Bolt, M5x20	2

ASSEMBLY 2 - CYLINDER HEAD SUBASSEMBLY, SPARK PLUG

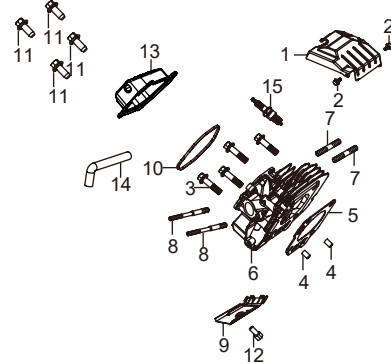

No.	Part No.	Description	Qty.
2-1	GN875i-0201	Cylinder Body Shroud, Primary	1
2-2	56200-1202	Bolt, M6x12	2
2-3	GN625i-0109	Cylinder Head Bolt, M10x80	4
2-4	GN625i-0110	Pin	2
2-5	DF875iX-0205	Cylinder Head Gasket	1
2-6	DF875iX-0206	Cylinder Head Subassembly	1
2-7	56310i-0109	Bolt, M8x34	2
2-8	GN875i-0208	Stud Bolt, M6/M8x110	2
2-9	GN875i-0209	Cylinder Body Shroud, Secondary	1
2-10	DF875iX-0210	Cylinder Head Cover Gasket	1
2-11	DF875iX-0211	Cylinder Head Cover Bolt (M6x14)	4
2-12	DF875iX-0212	Temperature Sensor	1
2-13	DF875iX-0213	Cylinder Head Cover Subassembly	1
2-14	DF875iX-0214	Breather Tube	1
2-15	DF875iX-0215	Spark Plug (Torch F7RTC / NGK BPR7ES)	1

EXPLODED VIEW & PARTS LIST

ASSEMBLY 3 - CRANKCASE COVER

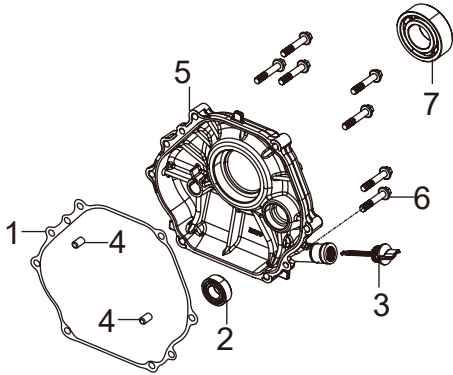

No.	Part No.	Description	Qty.
3-1	GN875i-0301	Crankcase Cover Gasket	1
3-2	GN875i-0302	Bearing, 6202P6	1
3-3	GN625i-0304	Oil Dipstick Subassembly	1
3-4	GN875i-0304	Pin	2
3-5	GN875i-0305	Crankcase Cover	1
3-6	GN875i-0306	Bolt, M8x40	7
3-7	GN875i-0307	Bearing, 6207P53	1

ASSEMBLY 4 - CRANKSHAFT, CONNECTING ROD, BALANCING SHAFT

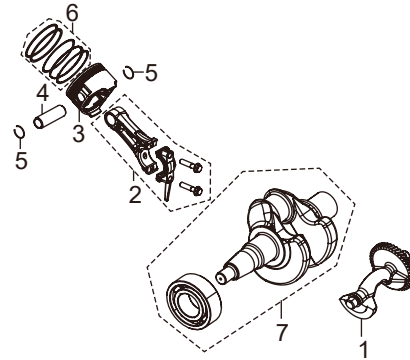

No.	Part No.	Description	Qty.
4-1	GN875i-0401	Balance Shaft Assembly	1
4-2	GN875i-0402	Connecting Rod Assembly	1
4-3	DF875iX-0403	Piston	1
4-4	GN875i-0404	Piston Pin	1
4-5	GN875i-0405	Piston Pin Clip	2
4-6	GN875i-0406	Piston Ring Set	1
4-7	GN875i-0407	Crankshaft Assembly	1

ASSEMBLY 5 - VALVE TRAIN, CAMSHAFT SUBASSEMBLY

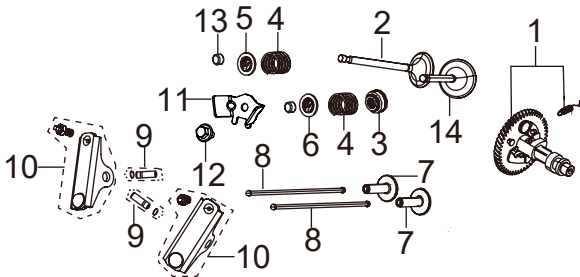

No.	Part No.	Description	Qty.
5-1	DF875iX-0501	Camshaft Assembly	1
5-2	DF875iX-0502	Exhaust Valve	1
5-3	DF875iX-0503	Seal Guide	1
5-4	DF875iX-0504	Valve Spring	2
5-5	DF875iX-0505	Exhaust Valve Retainer	1
5-6	DF875iX-0506	Intake Valve Retainer	1
5-7	GN875i-0510	Valve Tappet	2
5-8	DF875iX-0508	Valve Lifter Subassembly	2
5-9	DF875iX-0509	Rocker Shaft Subassembly	2
5-10	DF875iX-0510	Valve Rocker	2
5-11	DF875iX-0511	Cylinder Head Cover Pin Limit Plate	1
5-12	DF875iX-0512	Bolt, M6x12	1
5-13	DF875iX-0513	Valve Rotator	2
5-14	DF875iX-0514	Intake Valve	1

EXPLODED VIEW & PARTS LIST

ASSEMBLY 6 - RECOIL STARTER

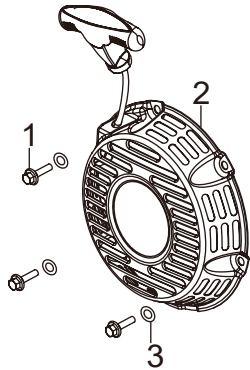

No.	Part No.	Description	Qty.
6-1	GN625i-0701	Bolt, M6x20	3
6-2	GN875i-0602	Recoil Starter Assembly	1
6-3	GN625i-0703	Flat Washer, 6mm	3

ASSEMBLY 7 - SHROUD, LOWER SHIELD

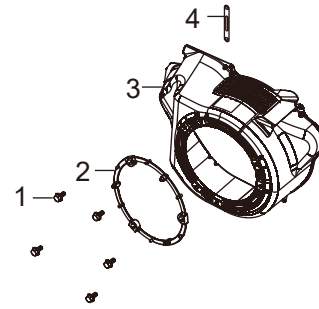

No.	Part No.	Description	Qty.
7-1	56200-1202	Bolt, M6x12	5
7-2	GN625i-0802	Retaining Ring	1
7-3	GN875i-0703	Shroud	1
7-4	GN400i-0703	Clip	1

ASSEMBLY 8 - CARBURETOR

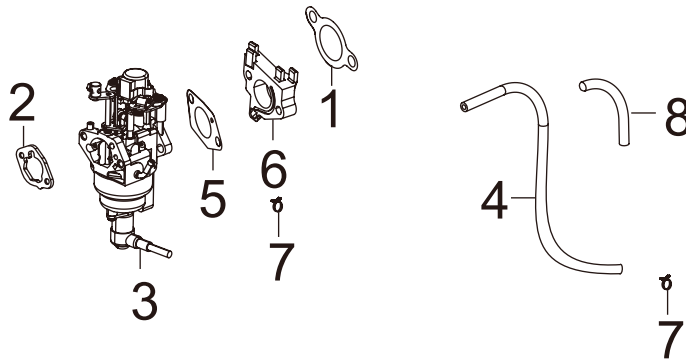

No.	Part No.	Description	Qty.	No.	Part No.	Description	Qty.
8-1	DF875iX-0801	Carburetor Insulator Gasket	1	8-5	GN875i-0805	Carburetor Gasket	1
8-2	GN625i-0901	Air Filter Gasket	1	8-6	DF875iX-0806	Carburetor Insulator Plate	1
8-3	DF875iX-0803	Carburetor Assembly	1	8-7	GN625i-0907	Hose Clamp	2
8-4	DF875iX-0804	Fuel Tube	1	8-8	DF875iX-0808	Rubber Jacket	1

EXPLODED VIEW & PARTS LIST

ASSEMBLY 9 - FLYWHEEL, IMPELLER, STARTER PULLEY

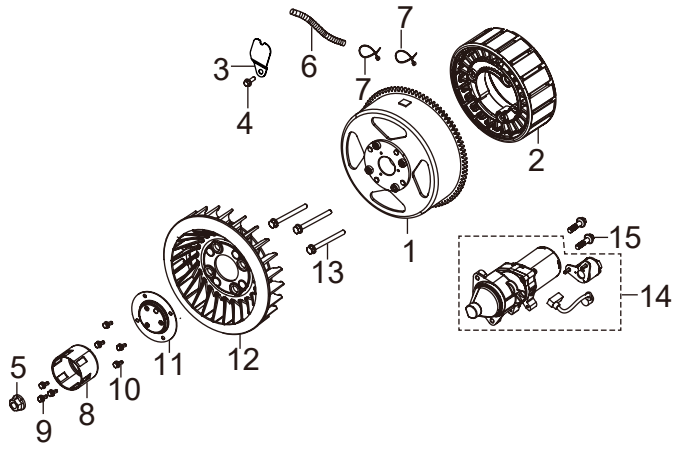

No.	Part No.	Description	Qty.
9-1	DF875iX-0901	Rotor	1
9-2	DF875iX-0902	Stator	1
9-3	GN625i-0214	Wiring Clamp	1
9-4	GN875i-0904	Bolt, M5x10	1
9-5	GN625i-1101	Flywheel Nut, M16-1.5	1
9-6	GN875i-0906	Wiring Sheath	1
9-7	GN875i-0907	Wiring Clip	2
9-8	GN625i-1103	Starter Pulley	1
9-9	56200-1202	Bolt, M6x12	3
9-10	56200-1202	Bolt, M6x12	4
9-11	DF875iX-0911	Starter Pulley Seat	1
9-12	DF875iX-0912	Impeller	1
9-13	GN875i-0913	Bolt, M6x65	3
9-14	GN875i-0914	Starter Motor Assembly	1
9-15	GN875i-0915	Bolt, M8x25	2

ASSEMBLY 10 - AIR FILTER

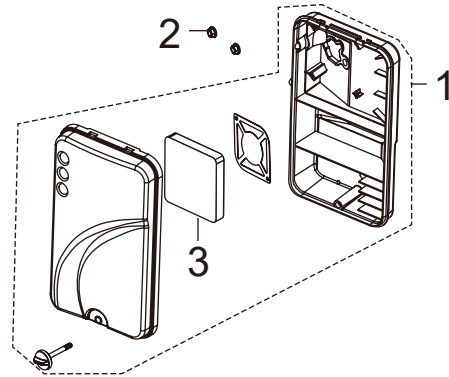

No.	Part No.	Description	Qty.
10-1	DF875iX-1001	Air Filter Assembly	1
10-2	56200-0506	Flanged Hex Nut, M6	2
10-3	GN875i-1003	Air Filter Element	1

ASSEMBLY 11 - MUFFLER ASSEMBLY

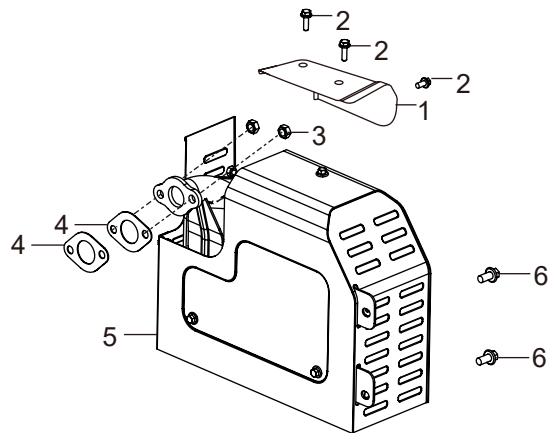

No.	Part No.	Description	Qty.
11-1	GN625i-1205	Outer Muffler Cover	1
11-2	GN625i-1206	Bolt, M6x12	3
11-3	GN400i-1108	Nut, M8	2
11-4	GN625i-1202	Muffler Gasket	2
11-5	GN875i-1105	Muffler Assembly	1
11-6	GN625i-1203	Bolt, M8x16	2
N.P.	GN625i-1201.1	Spark Arrestor	1

EXPLODED VIEW & PARTS LIST

ASSEMBLY 12 - FUEL TANK

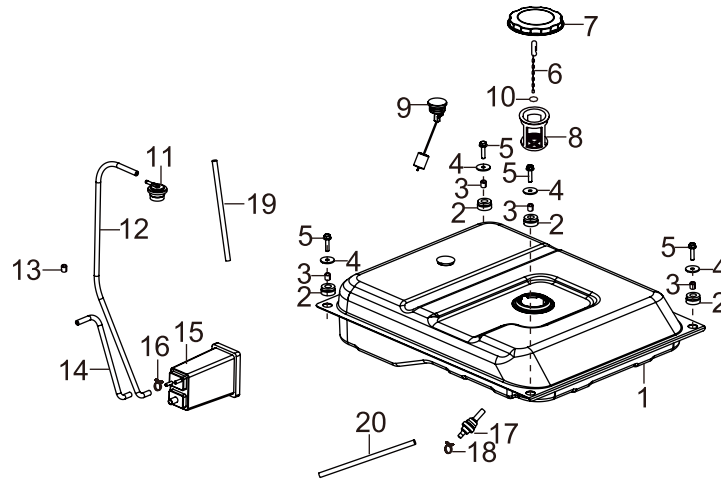

No.	Part No.	Description	Qty.	No.	Part No.	Description	Qty.
12-1	GN625i-1301	Fuel Tank	1	12-11	GN400i-1205	Breather Valve	1
12-2	56380i-1207	Fuel Tank Damper	4	12-12	GN875i-1212	Breather Hose	1
12-3	GN625i-1303	Bushing	4	12-13	GN400i-1316	Rubber Cover	1
12-4	GN625i-1304	Flat Washer, 6mm	4	12-14	GN875i-1214	Air Filter Hose	1
12-5	GN625i-1305	Bolt, M6x25	4	12-15	GN625i-1315	Carbon Tank	1
12-6	GN400i-1214	Fuel Tank Cap Chain	1	12-16	GN625i-1316	Hose Clamp A	1
12-7	GN400i-1202	Fuel Tank Cap	1	12-17	GN625i-1317	Fuel Tank Outlet	1
12-8	GN875i-1208	Fuel Strainer	1	12-18	GN625i-1318	Hose Clamp B	1
12-9	GN400i-1204	Fuel Gauge Assembly	1	12-19	GN625i-1319	Rubber Cover	1
12-10	GN625i-1310	Fuel Tank Chain Clip	1	12-20	DF875iX-1220	Fuel Tube	1

EXPLODED VIEW & PARTS LIST

ASSEMBLY 13 - FRAME

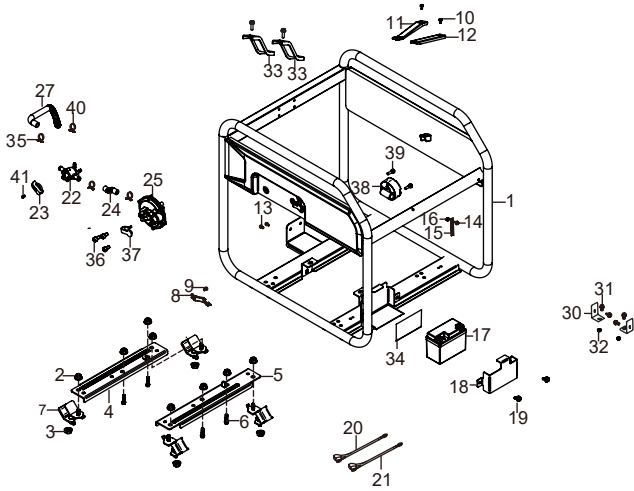

No.	Part No.	Description	Qty.
13-1	DF875iX-1301	Frame Assembly	1
13-2	GN625i-1402	Nut, M10-1.25	8
13-3	56310i-1404	Nut, M8	4
13-4	GN875i-1304	Engine Support Bracket 1	1
13-5	GN875i-1305	Engine Support Bracket 2	1
13-6	GN625i-1406	Bolt, M10-1.25x40	4
13-7	GN875i-1307	Engine Frame Damper	4
13-8	GN875i-1308	Air Filter Support	1
13-9	56200-1202	Bolt, M6x12	1
13-10	56200-1202	Bolt, M6x12	4
13-11	GN875i-1311	Inverter Support Bracket 1	1
13-12	GN875i-1312	Inverter Support Bracket 2	1
13-13	56200-0706	Bolt, M6x10	2
13-14	GN400i-1311	Bolt, M6x8	1
13-15	GN625i-1415	Clip	2
13-16	GN400i-1313	Nut, M6	1

No.	Part No.	Description	Qty.
13-17	56380i-1304	Battery (Li-ion, 12V, 1.6Ah)	1
13-18	GN875i-1318	Battery Clamp	1
13-19	56200-1202	Bolt, M6x12	2
13-20	GN875i-1320	Anode Wire	1
13-21	GN875i-1321	Cathode Wire	1
13-22	DF875iX-1322	Fuel Selector Switch	1
13-23	DF875iX-1323	Fuel Selector Switch Handle	1
13-24	DF875iX-1324	LPG Hose 1	1
13-25	DF875iX-1325	Secondary LPG Regulator	1
13-27	DF875iX-1326	LPG Hose 2	1
13-30	GN625i-1430	Shipping Bracket (Red)	2
13-31	GN400i-1104	Bolt, M8x16	4
13-32	GN625i-1432	Nut, M8	2
13-33	GN875i-1333	Inverter Support Bracket 3	2
13-34	GN875i-1334	Insulator Plate	1
13-35	DF875iX-1335	Hose Clamp	3
13-36	DF875iX-1336	Socket Head Cap Screw, M6x10	3
13-37	DF875iX-1337	LPG Inlet Cover	1
13-38	GN625iX-1430	CO Sensor Module	1
13-39	GN875iX-1332	Security Torx Screw, M4x25	2
13-40	DF875iX-1340	Hose Clamp	1
13-41	DF875iX-1341	Phillips-Head Screw, M4x10	1

EXPLODED VIEW & PARTS LIST

ASSEMBLY 14 - CONTROL PANEL

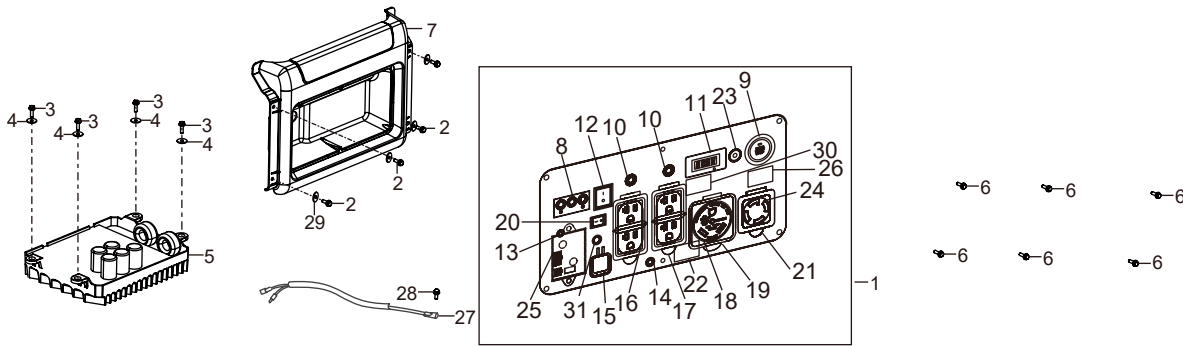

No.	Part No.	Description	Qty.	No.	Part No.	Description	Qty.
14-1	DF875iX-1401ASM	Control Panel Assembly	1	14-19	GN625i-1518	NEMA TT-30R Outlet Cover	1
14-2	GN625i-1502	Bolt, M6x16	4	14-20	56380i-1422	ECO-Mode Switch	1
14-3	GN625i-1503	Bolt, M6x20	4	14-21	GN625i-1521	NEMA L14-30R Outlet Cover	1
14-4	GN625i-1504	Flat Washer, 6mm	4	14-22	DF875iX-1422	Rectifier Bridge	1
14-5	GN875i-1405	Inverter	1	14-23	DF875iX-1423	Remote Pairing Button	1
14-6	GN625i-1506	Screw & Washer, M5x10	6	14-24	GN625i-1524	NEMA L14-30R Outlet	1
14-7	GN625i-1507	Panel Seat	1	14-25	DF875iX-1425	CO Sensor Engine Control Module	1
14-8	DF875iX-1408	Indicator Light Assembly	1	14-26	DF875iX-1426	Remote Control Receiver Module	1
14-9	DF875iX-1409	Engine Start/Stop Button	1	14-27	DF875iX-1427	Control Panel Wiring Harness	1
14-10	GN625i-1510	AC Breaker, 20A	2	14-28	DF875iX-1428	Hex Bolt, M6x10	1
14-11	DF875iX-1411	Multi-Meter	1	14-29	DF875iX-1429	Large Washer, 6mm	4
14-12	DF875iX-1412	Battery Switch	1	14-30	DF875iX-1430	Battery Charger Module	1
14-13	DF875iX-1413	CO Sensor LED Indicator	1	14-31	DF875iX-1431	Reset Button	1
14-14	GN400i-1413	Grounding Nut	1	N.P.	DF875iX-1432	Remote Control	1
14-15	GN625i-1515	USB Outlet Assembly	1	N.P.	DF875iX-1433	Primary LPG Regulator Hose Assembly	1
14-16	56380i-1421	NEMA 5-20R Duplex Outlet	2	N.P.	DF875iX-HA36	High Altitude Kit, 3000 - 6000 ft	1
14-17	GN625i-1516	NEMA 5-20R Outlet Cover	2	N.P.	DF875iX-HA68	High Altitude Kit, 6000 - 8000 ft	1
14-18	GN400i-1418B	NEMA TT-30R RV Outlet	1				

EXPLODED VIEW & PARTS LIST

ASSEMBLY 15 - WHEEL AND HANDLE

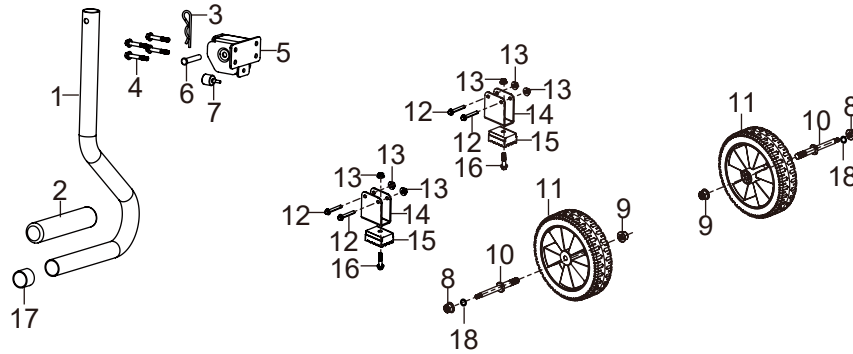

No.	Part No.	Description	Qty.	No.	Part No.	Description	Qty.
15-1	GN625i-1601	Handle Tube Assembly	1	15-10	GN625i-1610	Axle	2
15-2	GN625i-1602	Handle Sleeve	1	15-11	GN625i-1611	Wheel	2
15-3	GN625i-1603	R-clip	1	15-12	GN625i-1612	Bolt, M6x40	4
15-4	GN625i-1604	Bolt, M6x30	4	15-13	56200-0506	Nut, M6	6
15-5	GN625i-1605	Handle Bracket	1	15-14	GN625i-1614	Foot Bracket	2
15-6	GN625i-1606	Handle Pin	1	15-15	GN625i-1615	Foot Base	2
15-7	GN625i-1607	Handle Damper	1	15-16	56310I-1420	Bolt, M6x25	2
15-8	GN625i-1608	Nut, M8	2	15-17	GN625i-1617	Handle Tube Plug	1
15-9	GN625i-1609	Nut, M12-1.25	2	15-18	GN625i-1618	Flat Washer, 8mm	2

WARRANTY STATEMENT

WEN Products is committed to building tools that are dependable for years. Our warranties are consistent with this commitment and our dedication to quality.

LIMITED WARRANTY OF WEN PRODUCTS FOR HOME USE

GREAT LAKES TECHNOLOGIES, LLC (“Seller”) warrants to the original purchaser only, that all WEN consumer power tools will be free from defects in material or workmanship during personal use for a period of two (2) years from date of purchase or 500 hours of use; whichever comes first. Ninety days for all WEN products if the tool is used for professional or commercial use. Purchaser has 30 days from the date of purchase to report missing or damaged parts.

SELLER’S SOLE OBLIGATION AND YOUR EXCLUSIVE REMEDY under this Limited Warranty and, to the extent permitted by law, any warranty or condition implied by law, shall be the replacement of parts, without charge, which are defective in material or workmanship and which have not been subjected to misuse, alteration, careless handling, misrepair, abuse, neglect, normal wear and tear, improper maintenance, improper storage, incorrect lubricants/fuels, or other conditions adversely affecting the Product or the component of the Product, whether by accident or intentionally, by persons other than Seller. To make a claim under this Limited Warranty, you must make sure to keep a copy of your proof of purchase that clearly defines the Date of Purchase (month and year) and the Place of Purchase. Place of Purchase must be a direct vendor of Great Lakes Technologies, LLC. Purchasing through third party vendors, including but not limited to garage sales, pawn shops, resale shops, or any other secondhand merchant, voids the warranty included with this product. Contact techsupport@wenproducts.com or 1-800-232-1195 with the following information to make arrangements: your shipping address, phone number, serial number, required part numbers, and proof of purchase. Damaged or defective parts and products may need to be sent to WEN before the replacements can be shipped out.

Upon the confirmation of a WEN representative, your product may qualify for repairs and service work. When returning a product for warranty service, the shipping charges must be prepaid by the purchaser. The product must be shipped in its original container (or an equivalent), properly packed to withstand the hazards of shipment. The product must be fully insured with a copy of the proof of purchase enclosed. There must also be a description of the problem in order to help our repairs department diagnose and fix the issue. Repairs will be made and the product will be returned and shipped back to the purchaser at no charge for addresses within the contiguous United States.

THIS LIMITED WARRANTY DOES NOT APPLY TO ITEMS THAT WEAR OUT FROM REGULAR USAGE OVER TIME, INCLUDING FILTERS, SPARK PLUGS, VOLTAGE REGULATORS, BRUSHES, GASKETS, O-RINGS, WHEEL KITS, BATTERIES, RECOIL STARTERS, HIGH PRESSURE HOSES, SPRAY GUNS, ETC. ANY IMPLIED WARRANTIES SHALL BE LIMITED IN DURATION TO TWO (2) YEARS FROM DATE OF PURCHASE. SOME STATES IN THE U.S. AND SOME CANADIAN PROVINCES DO NOT ALLOW LIMITATIONS ON HOW LONG AN IMPLIED WARRANTY LASTS, SO THE ABOVE LIMITATION MAY NOT APPLY TO YOU.

IN NO EVENT SHALL SELLER BE LIABLE FOR ANY INCIDENTAL OR CONSEQUENTIAL DAMAGES (INCLUDING BUT NOT LIMITED TO LIABILITY FOR LOSS OF PROFITS) ARISING FROM THE SALE OR USE OF THIS PRODUCT. SOME STATES IN THE U.S. AND SOME CANADIAN PROVINCES DO NOT ALLOW THE EXCLUSION OR LIMITATION OF INCIDENTAL OR CONSEQUENTIAL DAMAGES, SO THE ABOVE LIMITATION OR EXCLUSION MAY NOT APPLY TO YOU.

THIS LIMITED WARRANTY GIVES YOU SPECIFIC LEGAL RIGHTS, AND YOU MAY ALSO HAVE OTHER RIGHTS WHICH VARY FROM STATE TO STATE IN THE U.S., PROVINCE TO PROVINCE IN CANADA AND FROM COUNTRY TO COUNTRY.

THIS LIMITED WARRANTY APPLIES ONLY TO ITEMS SOLD WITHIN THE UNITED STATES OF AMERICA, CANADA AND THE COMMONWEALTH OF PUERTO RICO. FOR WARRANTY COVERAGE WITHIN OTHER COUNTRIES, CONTACT THE WEN CUSTOMER SUPPORT LINE. FOR WARRANTY PARTS OR PRODUCTS REPAIRED UNDER WARRANTY SHIPPING TO ADDRESSES OUTSIDE OF THE CONTIGUOUS UNITED STATES, ADDITIONAL SHIPPING CHARGES MAY APPLY.

**THANKS FOR
REMEMBERING**

