

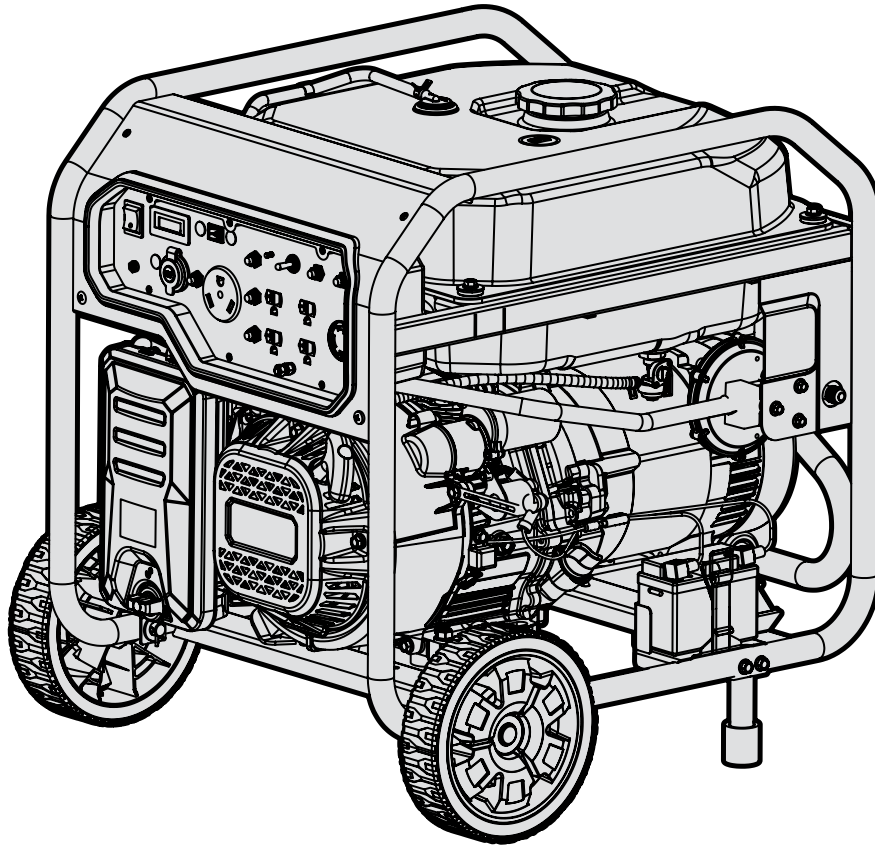

MODEL DF8000X

8000W ELECTRIC START DUAL FUEL GENERATOR

Instruction Manual



NEED HELP? CONTACT US!

Have product questions? Need technical support? Please feel free to contact us:



1-847-429-9263 (M-F 8AM-5PM CST)



TECHSUPPORT@WENPRODUCTS.COM

IMPORTANT: Your new tool has been engineered and manufactured to WEN's highest standards for dependability, ease of operation, and operator safety. When properly cared for, this product will supply you years of rugged, trouble-free performance. Pay close attention to the rules for safe operation, warnings, and cautions. If you use your tool properly and for its intended purpose, you will enjoy years of safe, reliable service.

For replacement parts and the most up-to-date instruction manuals, visit ***WENPRODUCTS.COM***

CONTENTS

WELCOME	3
Specifications.....	3
Introduction	4
SAFETY	5
Safety Information	5
Generator Safety Warnings	6
BEFORE OPERATING	9
Unpacking & Packing List.....	9
Know Your Generator.....	10
Assembly & Adjustments.....	12
Generator Preparation.....	13
OPERATION & MAINTENANCE	20
Starting Your Generator	20
Using Your Generator.....	22
Shutting Off Your Generator.....	27
Maintenance.....	28
Transportation & Storage.....	36
Troubleshooting Guide.....	37
Wiring Diagram.....	38
Exploded View & Parts List.....	39
Warranty Statement	45

To purchase accessories for your tool, visit ***WENPRODUCTS.COM***

Magnetic Oil Dipstick (Model GNA273)

Weatherproof Generator Cover, Medium (Model 56406)

High-Altitude Kit (Part DF8000X-HA36 and DF8000X-HA68)

SPECIFICATIONS

GENERATOR

Rated Wattage	Gasoline: 6500 Watts
	LPG: 5850 Watts
Surge Wattage	Gasoline: 8000 Watts
	LPG: 7200 Watts
Rated Voltage	120V / 240V
Rated Amperage	54.1A (Gasoline) / 48.7A (LPG)
Phase	Single
Frequency	60 Hz
Product Dimensions	With Wheel & Handle Kit: 28.54 in. x 24.61 in. x 24.96 in.
	Without Wheel & Handle Kit: 24.72 in. x 19.41 in. x 21.61 in.
Product Weight	With Wheel & Handle Kit: 138.78 Pounds
	Without Wheel & Handle Kit: 132.72 Pounds

ENGINE

Engine Type	4-Stroke, OHV, Single Cylinder with Forced Air Cooling System
Engine Displacement	340cc
Fuel Tank Capacity	6.70 Gallons (25.40 L), 87 Octane Minimum
Oil Capacity	30.4 fl. oz. (0.90 L)
Half-Load Run Time	Gasoline: 10.5 Hours
Lubrication System	Splash Lubrication
Spark Plug Type	Torch F7RTC (NGK BPR7ES)
Spark Plug Gap	0.028 in. - 0.031 in. (0.7mm - 0.8mm)
Spark Plug Torque	20 - 22 ft-lbs (27 - 30 Nm)
Battery	12V, 1.6Ah, Lithium-Ion

INTRODUCTION

Thanks for purchasing the WEN 8000-Watt Dual Fuel Generator. Refer to the illustration below for the location of the serial number on the specifications label. Record the generator information in the spaces provided below. If assistance for information or service is required, please contact customer service by calling **1-847-429-9263**, M-F 8-5 CST; you will be asked to provide the following generator information when calling.

Generator Model Number: DF8000X

Date of Purchase: _____

Purchased From: _____

Serial Number: _____

CAUTION!

HIGH TEMPERATURE,
DO NOT TOUCH!

8000W DUAL FUEL GENERATOR

RATED WATTAGE (GAS)	6500W	RATED VOLTAGE	120V / 240V
RATED WATTAGE (LPG)	5850W	RATED FREQUENCY	60 Hz
SURGE WATTAGE (GAS)	8000W	GAS TANK CAPACITY	6.70 GAL (25.4L)
SURGE WATTAGE (LPG)	7200W	OIL CAPACITY	30.4 fl. oz. (0.9L)
SERIAL NUMBER	● _____		
ENGINE SERIAL NUMBER	● _____		

1-847-429-9263 WENPRODUCTS.COM

Great Lakes Technologies LLC • 1101 Wesemann Drive • West Dundee, IL 60118

MODEL
DF8000X

TYPE 1
MADE IN
VIETNAM

GÉNÉRATEUR
BI-CARBURANT

Serial Number

SERVICE RECORD

Record the service dates of your generator in the chart below. Please perform maintenance checks and operations according to the "Maintenance" section of the manual.

Service Record	Date	Date	Date	Date	Date	Date
Change Oil						
Change Spark Plug						
Clean Fuel Tank						
Clean Air Filter						
Clean Spark Arrestor						

TO MAXIMIZE THE LIFESPAN OF YOUR GENERATOR: We recommend running your generator at least once a month for 20 to 30 minutes. Start the generator according to the instructions and plug a small load in to make sure the outlet is producing electricity.

SAFETY INFORMATION

 **WARNING!** Before operating the generator, make sure to read all safety warnings and all instructions. Failure to follow the warnings and instructions may result in electric shock, fire or serious injury.

SAFETY INTRODUCTION

Safety is a combination of common sense, staying alert, and knowing how your tool works. This manual contains important information regarding the generator's potential safety concerns, as well as preparation, operation, and maintenance instructions. Before operating this generator, be sure to read and observe all warnings and instructions both on the generator labels and in this instruction manual. Failure to follow all instructions listed below may result in personal injury.

NOTE: The following safety information is not meant to cover all possible conditions and situations that may occur. WEN reserves the right to change this product and specifications at any time without prior notice.

At WEN, we are continuously improving our products. If you find that your tool does not exactly match this manual, please visit wenproducts.com for the most up-to-date manual or contact customer service at **1-847-429-9263**, M-F 8-5 CST.

Keep this manual available to all users during the entire life of the tool and review it frequently to maximize safety for both yourself and others.

SAVE THESE SAFETY INSTRUCTIONS.

SAFETY SYMBOLS

The purpose of following safety symbols is to attract your attention to possible dangers. The safety symbols, and their explanations, deserve your careful attention and understanding. The safety warnings do not by themselves eliminate any danger. The instructions or warnings they give are not substitutes for proper accident prevention measures.

 **DANGER:** indicates a hazard, which, if not avoided, will result in death or serious injury.

 **WARNING:** indicates a hazard, which, if not avoided, could result in death or serious injury.

 **CAUTION:** indicates a hazard, which, if not avoided, might result in minor or moderate injury.

CAUTION! when used without the alert symbol, indicates a situation that could result in damage to the machine.

NOTICE REGARDING EMISSIONS

Engines that are certified to comply with U.S. EPA emission regulations for SORE (Small Off Road Equipment), are certified to operate on regular unleaded gasoline, and may include the following emission control systems: (EM) Engine Modifications and (TWC) Three-Way Catalyst (if so equipped).

QUESTIONS? PROBLEMS?

In order to answer questions and solve problems in the most efficient and speedy manner, contact customer service at **1-847-429-9263**, M-F 8-5 CST or email techsupport@wenproducts.com.

GENERATOR SAFETY WARNINGS

DANGER! CARBON MONOXIDE

Using a generator indoors **CAN KILL YOU IN MINUTES**. Generator exhaust contains carbon monoxide (CO). This is a poison gas you cannot see or smell. If you can smell the generator exhaust, you are breathing CO. But even if you cannot smell the exhaust, you could be breathing CO.





NEVER use a generator inside homes, garages, crawl spaces, or other partially enclosed areas. Deadly levels of carbon monoxide can build up in these areas. Using a fan or opening windows and doors does **NOT** supply enough fresh air. **ONLY** use a generator outside and far away from windows, doors, and vents. These openings can pull in generator exhaust.

Even if you use a generator correctly, CO may leak into the home. **ALWAYS** use a battery-powered or battery-backup CO alarm in the home. If you start to feel sick, dizzy, or weak after the generator has been running, move to fresh air **RIGHT AWAY**. See a doctor. You may have carbon monoxide poisoning.

 **WARNING! RISK OF EXPLOSION. HIGHLY FLAMMABLE:** This generator may emit highly flammable and explosive gasoline vapors, which can cause severe burns or even death, if ignited. A nearby open flame can lead to explosion even if not directly in contact with gasoline.

- Do not operate near open flame, heat, or any other ignition source. Do not smoke near the generator.
- Always operate on a firm, level surface.
- Always turn generator off before refueling. Allow generator to cool for at least 2 minutes before removing fuel cap. Loosen cap slowly to relieve pressure in tank.
- Do not overfill fuel tank. Gasoline may expand during operation. Do not fill to the top of the tank. Allow for expansion. Always check for spilled fuel before operating.
- If fuel spills, move the generator at least 30 feet away from the spill and wipe clean any spilled fuel before starting the engine.
- Empty fuel tank before storing or transporting the generator.

 **WARNING!** If this generator is used as a supply for a building's wiring system, the generator must be installed by a qualified electrician and connected to a transfer switch as a separately derived system in accordance with all applicable laws and electrical codes and the National Electrical Code, NFPA 70. The generator shall be connected to a transfer switch that switches all conductors excluding the equipment grounding conductor. The frame of the generator shall be connected to an approved grounding electrode.

 **CALIFORNIA PROPOSITION 65 WARNING:** This product contains chemicals and produces exhaust known to the State of California to cause cancer, birth defects and other reproductive harm.

GENERATOR SAFETY WARNINGS

⚠ WARNING! Do not let comfort or familiarity with the product replace strict adherence to product safety rules. Failure to follow the safety instructions may result in serious personal injury.

⚠ WARNING

- **INGESTION HAZARD:** This product contains a button cell or coin battery.
- **DEATH** or serious injury can occur if ingested.
- A swallowed button cell or coin battery can cause **Internal Chemical Burns** in as little as **2 hours**.
- **KEEP** new and used batteries **OUT OF THE REACH** of **CHILDREN**.
- **Seek immediate medical attention** if a battery is suspected to be swallowed or inserted inside any part of the body.



BUTTON OR COIN CELL BATTERY SAFETY INFORMATION

PLEASE READ THE FOLLOWING CAREFULLY:

1. Remove and immediately recycle or dispose of used batteries according to local regulations and keep away from children. Do NOT dispose of batteries in household trash or incinerate.
2. Even used batteries may cause severe injury or death.
3. Call a local poison control center for treatment information.
4. The compatible battery type is CR2032 and the nominal battery voltage is 3V.
5. Non-rechargeable batteries are not to be recharged.
6. Do not force discharge, recharge, disassemble, heat above 158°F, or incinerate. Doing so may result in injury due to venting, leakage or explosion resulting in chemical burns.

NOTE: THIS PRODUCT CONTAINS NON-REPLACEABLE BATTERIES.

OPERATING ENVIRONMENT

1. **Using a generator indoors can kill you in minutes.** Only use a generator outside and far away from windows, doors and vents.
2. **Do not smoke near the generator.**
3. **Do not operate near open flame, heat, or flammable materials.** This generator may emit highly flammable and explosive gasoline vapors, which can cause severe burns or even death if ignited. A nearby open flame can lead to an explosion even if it isn't directly in contact with gasoline.
4. **Do not expose the generator to rainy or wet conditions; doing so significantly increases the risk of electrical shock.** Never handle the generator, electronic devices, or any cord while standing in water, while barefoot, or when hands or feet are wet.
5. **Always operate the generator on a dry, firm, level surface.**
6. **The generator should have at least 5 feet of clearance from buildings or other equipment during operation.**
7. **Do not allow children or non-qualified persons to operate the generator.**

GENERATOR SAFETY WARNINGS

⚠ WARNING! Do not let comfort or familiarity with the product replace strict adherence to product safety rules. Failure to follow the safety instructions may result in serious personal injury.

TO MAXIMIZE THE LIFESPAN OF YOUR GENERATOR: We recommend running your generator at least once a month for 20 to 30 minutes. Start the generator according to the instructions and plug a small load in to make sure the outlet is producing electricity. If you do not run it often, it will greatly shorten the generator's lifespan and void the warranty.

GENERATOR PREPARATION

1. **Always ground the generator before using it to maximize safety** (see "Ground the Generator" section).
2. **Do not overfill fuel tank, as gasoline may expand during operation.** Do not fill to the very top of the tank. Leave room for gasoline expansion. Always check for spilled fuel before operating.
3. **If any part of the generator, electrical device or power cord is broken, damaged, or defective, make sure it is repaired or replaced before operation.** Service should only be performed by a qualified technician. Do not use receptacles or cords that show signs of damage, such as broken or cracked insulation.
4. **Use a ground fault circuit interrupter (GFCI) in highly conductive areas such as metal decking or steel work.** Extension cords with in-line GFCIs are recommended for these operations to maximize safety.
5. **If connecting the generator to a building's electrical system for standby power, you MUST consult a qualified electrician and install a transfer switch.** Such connections must comply with local electrical laws and codes. Failure to comply can create a back-feed, which may result in serious injury or death to utility workers.
6. **Never modify the generator in any way.** Modifying or using the machine for any other purpose for which it is not designed may result in serious injuries, machine damage and voiding of the warranty.

GENERATOR OPERATION

1. **Only use the generator for its intended purposes.** Modifying or using the generator for operations for which it was not designed may cause hazards and personal injury.
2. **Do not touch bare wires or receptacles (outlets).**
3. **Do not turn on electrical devices until after they are connected to the generator.**









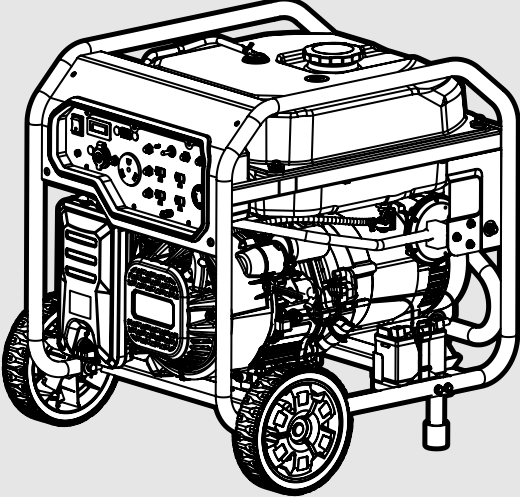
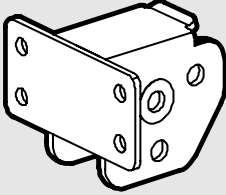

4. **Do not exceed the wattage capacity of the generator by plugging in more electrical devices than the unit can handle.** This could damage the generator and/or connected electrical devices. Check the operating voltage and frequency requirements of all electrical devices prior to plugging them into the generator.
5. **Allow generator to run for several minutes before connecting electrical devices.** Do not start or stop engine with electrical devices plugged in to the receptacles. Failure to do so could damage the generator and/or connected electrical devices.
6. **Generators vibrate in normal use.** During and after the use of the generator, inspect both the generator as well as extension and power supply cords for damage resulting from vibration.
7. **Do not touch hot parts.** This generator produces heat when running. Temperatures near exhaust can exceed 150°F (65°C). Allow generator to cool down after use before touching engine or areas of the generator that become hot during use.
8. **Turn off all connected electrical devices before stopping the generator.**
9. **Always turn generator off before refueling.** Allow generator to cool for at least 2 minutes before removing fuel cap. Loosen cap slowly to relieve pressure in tank.
10. **Turn the engine switch and fuel selector knob to "OFF" position when the engine is not running.**
11. **Empty fuel tank before storing or transporting the generator.** Do not store generator or gasoline near furnaces, water heaters, or any other appliances that produce heat or have automatic ignitions. Store the generator and fuel away from sparks, open flames, pilot lights, heat and other sources of ignition.
12. **Always wash hands after handling generator.**

UNPACKING & PACKING LIST

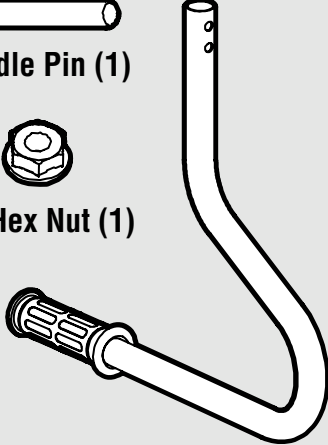
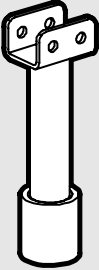
UNPACKING

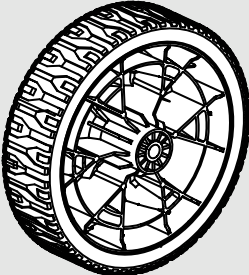
With the help of a friend or trustworthy foe, such as one of your in-laws, carefully remove the generator from the packaging and place it on a sturdy, flat surface. Make sure to take out all contents and accessories. Do not discard the packaging until everything is removed. Check the packing list below to make sure you have all of the parts and accessories. If any part is missing or broken, please contact customer service at **1-847-429-9263** (M-F 8-5 CST), or email techsupport@wenproducts.com.

PACKING LIST

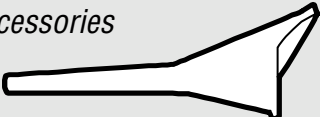
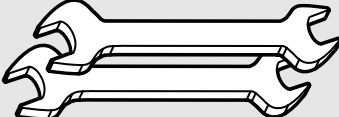
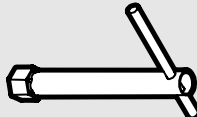
<p><i>Components</i></p>  <p>Generator</p>	<p><i>Handle Assembly</i></p>  <p>Handle Bracket (1)</p>  <p>Handle Pin (1)</p>  <p>M8 Hex Nut (1)</p>  <p>M8x48 Hex Bolt (1)</p>  <p>M8x16 Hex Bolts (4)</p>  <p>Handle (1)</p>	
<p><i>Foot Support Assembly</i></p>  <p>Foot Assembly (2)</p>  <p>M6x40 Hex Bolt (4)</p>  <p>M6 Hex Nut (4)</p>	<p><i>Wheel Assembly</i></p>  <p>Wheels (2)</p>  <p>Axle Pins (2)</p>  <p>R-Clips (2)</p>  <p>Washer (2)</p>	<p><i>Accessories</i></p>  <p>Funnel (1)</p>  <p>Wrenches (2) (8-10mm, 10-13mm)</p>  <p>Spark Plug Socket (1)</p>

KNOW YOUR GENERATOR

TOOL PURPOSE

Portable generators provide you with power when and where you need it most. Refer to the following diagrams to become familiarized with all the parts and controls of your generator. The components will be referred to later in the manual for assembly and operation instructions.

GENERATOR

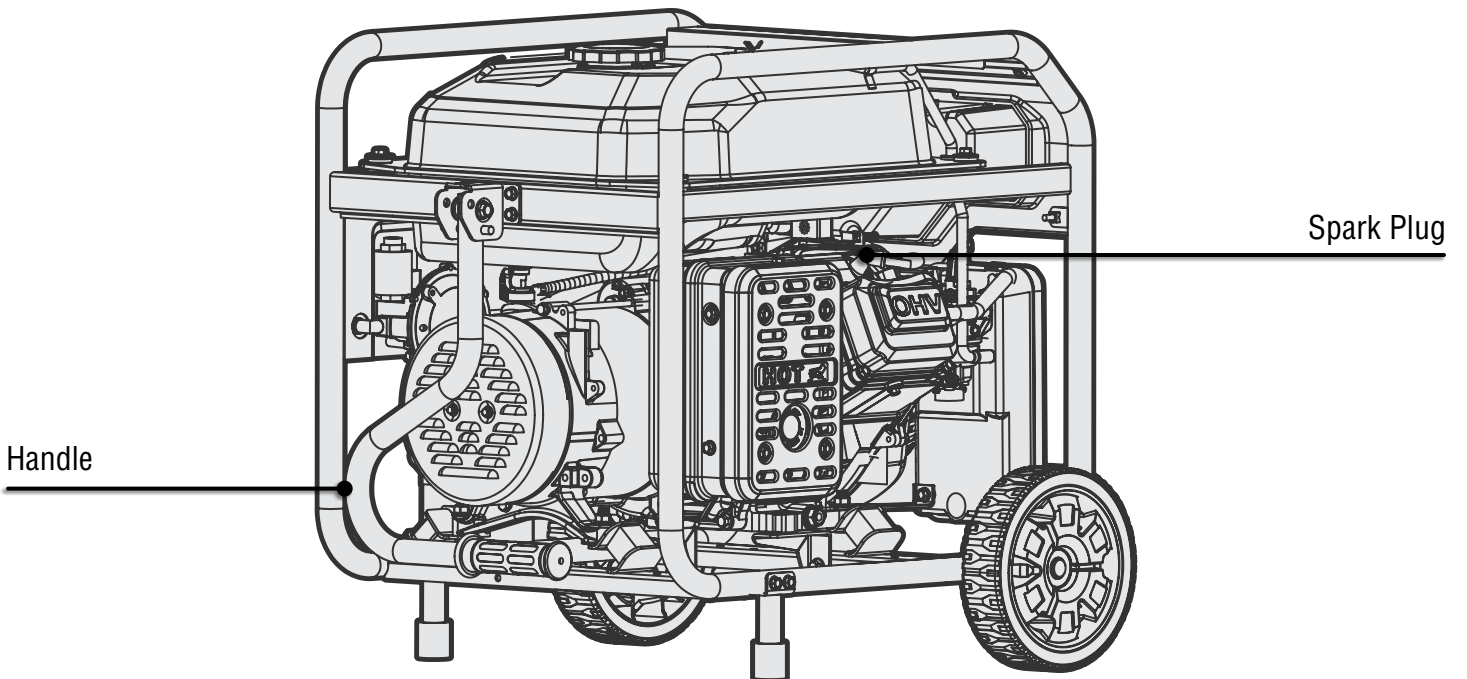
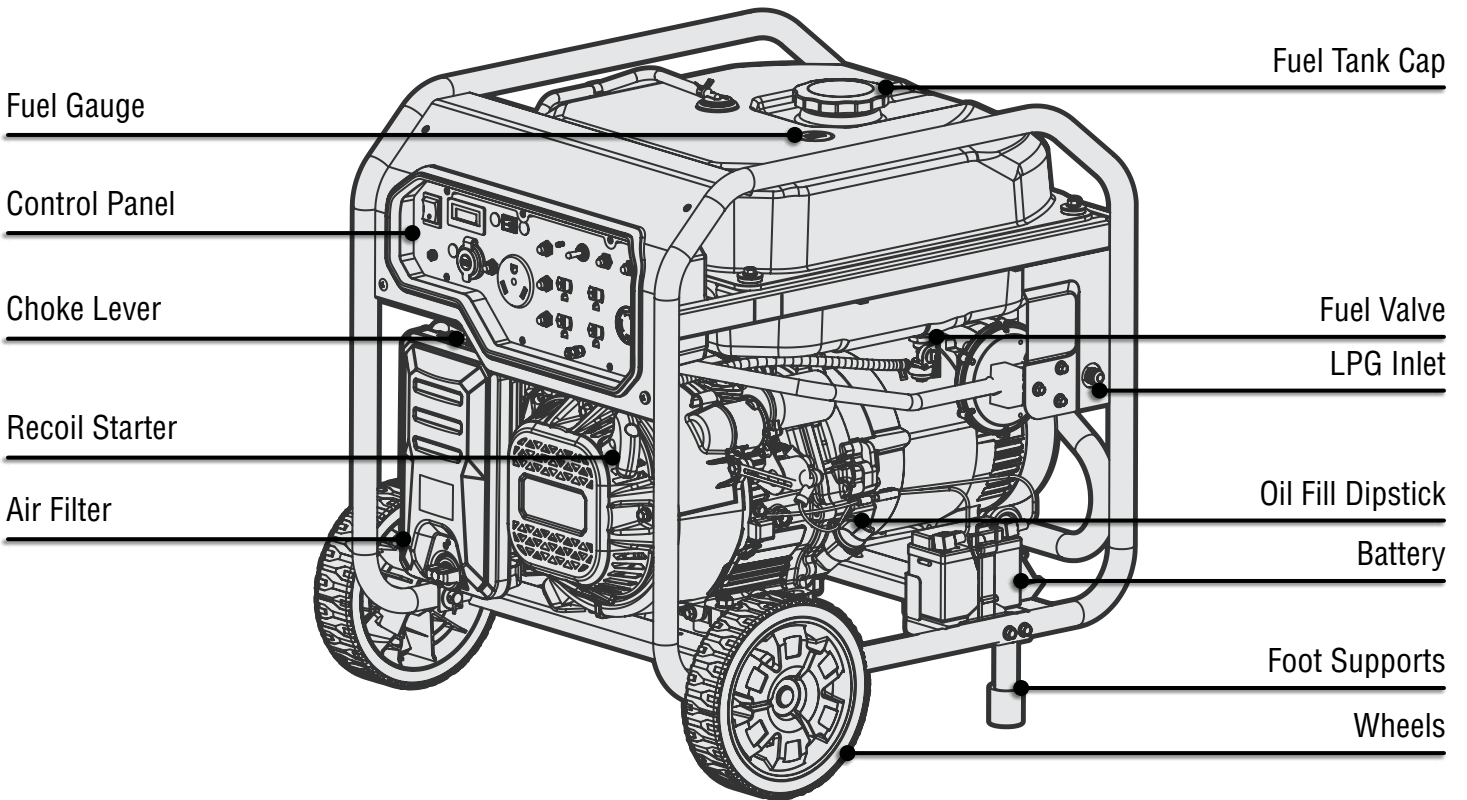

KNOW YOUR GENERATOR

CONTROL PANEL

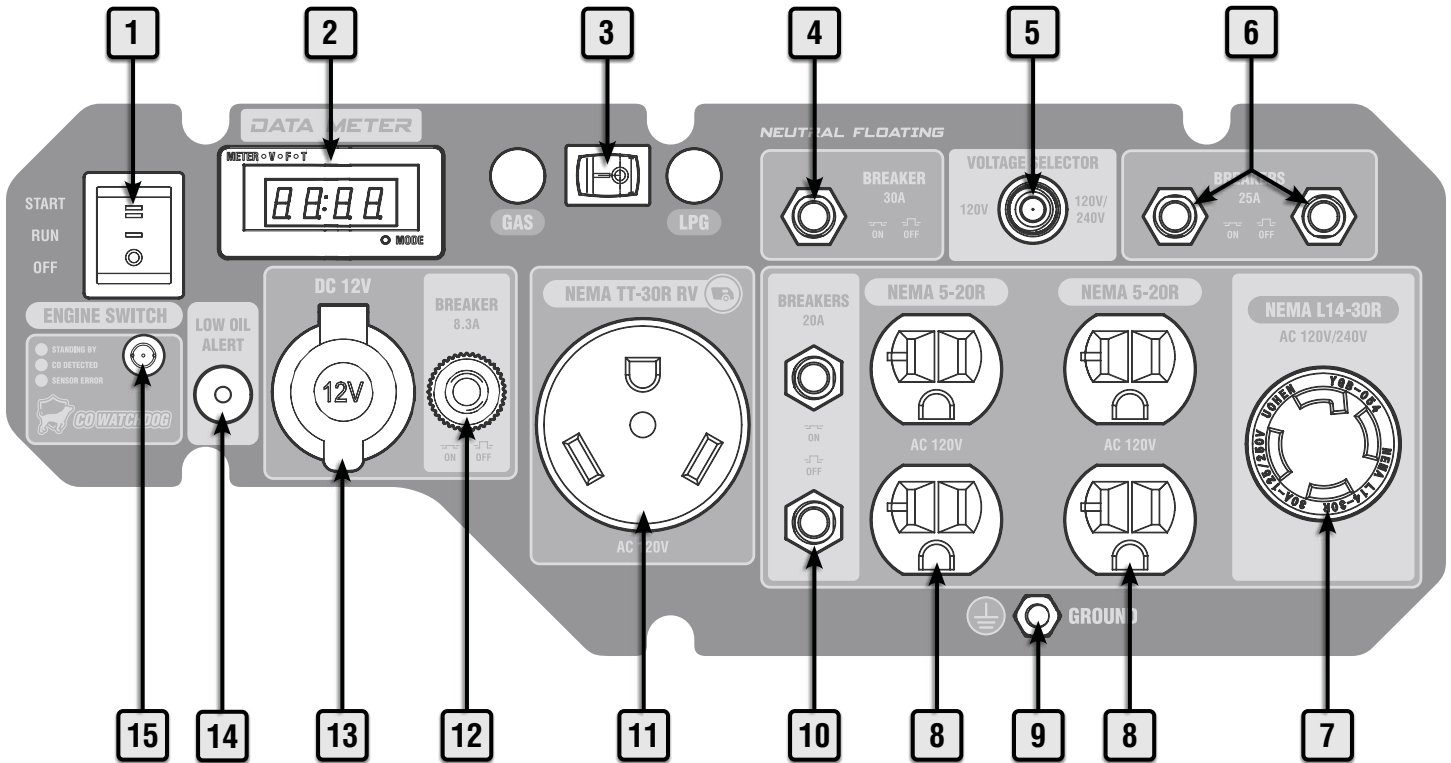

1. Engine Switch

Start the engine using this switch.

2. Data Meter

Displays voltage, frequency, total runtime (HHHH), and session runtime (HH:MM). Press the MODE button to switch between displays.

3. Fuel Selector Switch

Easily switch between gasoline or LPG before or during operation. See p. 24 for more information.

4. Circuit Breaker (30A)

5. Voltage Selector Switch

Switch between 120V and 240V outlets. When the switch is set to "120V", the 120V outlets are active; when the switch is set to "120V/240V", the L14-30R outlet is active.

6. Circuit Breakers (25A)

7. NEMA L14-30R

AC 120V/240V split-phase. Only active when "120V/240V" is selected.

8. AC 120V NEMA 5-20R Duplex Receptacles (20A)

Standard household outlets provide 120V 60Hz power.

9. Grounding Nut

Ground generator to reduce risk of electric shock.

10. Circuit Breakers (20A)

11. AC 120V NEMA TT-30R RV Receptacle (30A)

Standard RV connector.

12. Circuit Breaker (8.3A)

13. DC 12V Cigarette-Lighter Style Receptacle

14. Low Oil Alert

Illuminates if the oil level is too low.

15. CO WATCHDOG Carbon Monoxide Monitor

Measures the accumulation of poisonous CO gas while the generator is running. If the level of CO gas gets too high, the CO Watchdog system will automatically shut down the generator. See p. 26 for more information.

ASSEMBLY & ADJUSTMENTS

⚠ WARNING! Do not turn the generator on until it is fully assembled according to the instructions. Read through and become familiarized with the following procedures of handling and adjusting your generator. Failure to follow the safety instructions may result in serious personal injury.

- Never use the handle as a lifting point to support the entire weight of the generator. Only use the handle to pull the generator with the help of the wheels.
- Use caution when collapsing the handle. Hands and fingers could get caught and pinched.

ASSEMBLY

Refer to the packing list on p. 9 to gather the proper parts and tools for installing the feet, wheels, and handles.

NOTE: There are different sizes of bolts/nuts; be sure to use the proper bolts/nuts for each assembly step.

INSTALLING THE FOOT SUPPORTS (FIG. A)

The foot supports are installed on the base of the generator, towards the rear, opposite the control panel.

1. Prepare a set of blocks on level ground (a 4x4 block of wood works well). Place the generator on the blocks. Have someone help you lift the generator.

2. Align the holes on the foot bracket (Fig. A - 1) with the holes on the generator frame. Slide two M6x40 hex bolts (Fig. A - 2) through the foot bracket and generator frame and secure them using two M6 hex bolts (Fig. A - 3). Tighten the bolts using the included wrench. Repeat for the other foot support.

INSTALLING THE WHEELS (FIG. B)

The wheels are installed on either side of the generator, towards the front, beside the control panel.

1. Align the wheel (Fig. B - 1) with the hole on the generator frame. Slide the axle pin (Fig. B - 2) through the wheel, washer (Fig. B - 3), and generator frame. Repeat for the other wheel.

2. Insert the R-clip (Fig. B - 4) through the hole in the axle pin and lock the wheel in place. Repeat for the other wheel.

INSTALLING THE HANDLES (FIG. C)

The handle is installed on the rear of the generator, opposite the control panel.

1. Secure the handle bracket (Fig. C - 1) to the generator frame (Fig. C - 2) using four M8x16 bolts (Fig. C - 3).

2. Fit the handle (Fig. C - 4) into the handle bracket. Make sure that the holes align properly. Slide the handle pin (Fig. C - 5) through the bottom holes of the handle and handle bracket as shown in Fig. C.

3. Secure the handle to the handle bracket using an M8x48 bolt (Fig. C - 6) and an M8 nut (Fig. C - 7) through the top holes of the handle and handle bracket as shown in Fig. C.

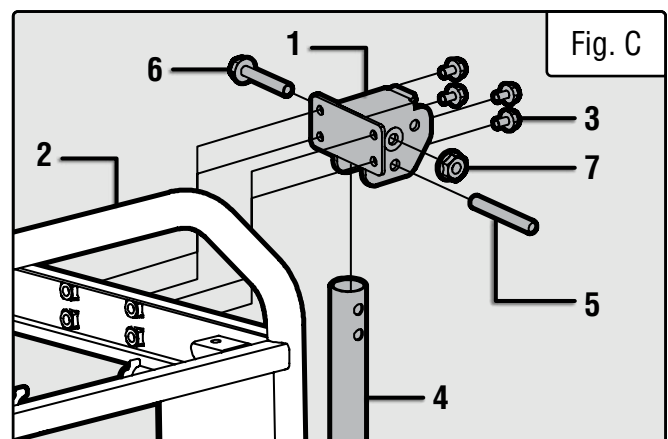
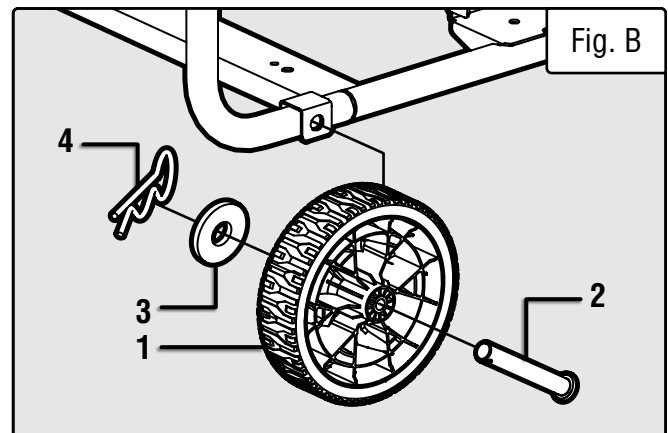
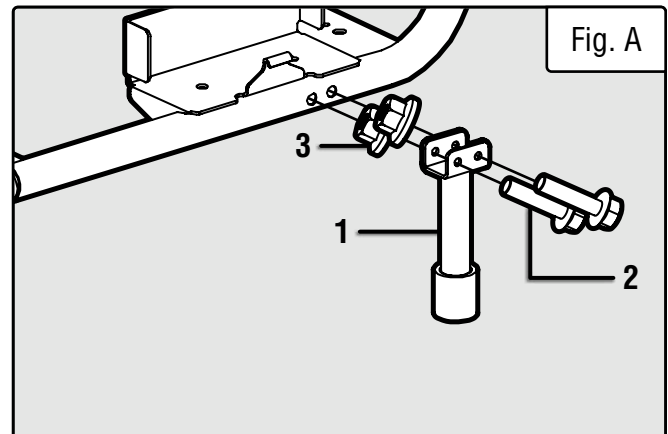

GENERATOR PREPARATION

REMOVING THE SHIPPING BRACKETS

Your generator is shipped with two shipping brackets in order to prevent machine damage during shipping. Make sure to remove the shipping brackets before operating your generator. Failure to do so could lead to engine damage.

1. With the help of another person, place generator on an elevated platform such as table or workbench. Make sure the generator is stable. Remove the shipping brackets. Do not tilt the generator as there may be remaining oil inside the crankcase from testing.

The following section describes the necessary steps to prepare the generator for use. If you are unsure about how to perform any of the steps, please call **1-847-429-9263** M-F 8-5 CST for customer service. Failure to perform these steps properly can damage the generator or shorten its life.

STEP 1 - ADD / CHECK OIL

The generator is shipped without oil. User must add the proper amount of oil before operating the generator for the first time. The oil capacity of the engine crankcase is **30.4 fl. oz. (0.90 L)**.

ENGINE OIL RECOMMENDATIONS

Select good quality detergent oil bearing the American Petroleum Institute (API) service classifications SJ, SL, or SM (synthetic oils may be used). Select the SAE viscosity grade of oil that matches the expected operating temperature.

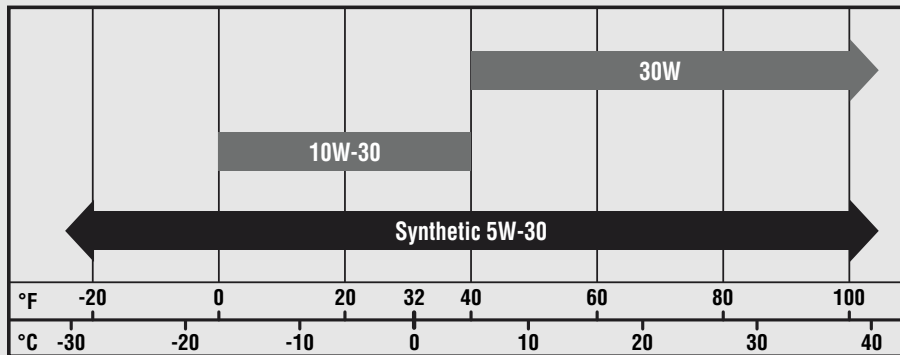

- **30W Engine Oil**
Temperatures above 40°F
- **10W-30 Engine Oil**
Temperatures between 0°F - 40°F
- **Synthetic 5W-30 Engine Oil**
All temperature ranges

To add oil, follow these steps:

1. Place the generator on a level surface. Make sure the engine is off before adding or checking oil.

CAUTION: Keep the generator level! Tilting the generator to assist in filling will cause oil to flow into the wrong areas of the engine and cause damage.

2. Turn the dipstick (Fig. 1 - 1) counterclockwise until it is unscrewed from the engine.

3. Using an oil funnel or appropriate dispenser, slowly add oil into the oil fill, being careful not to overfill the unit. Fill the crankcase until you can see the oil coming halfway up the oil fill threads (Fig. 2).

4. Reinstall the oil dipstick and firmly tighten it. Wipe clean any spilled oil.

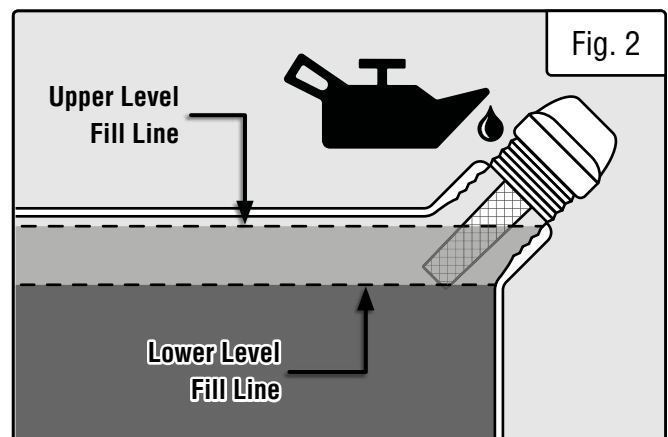
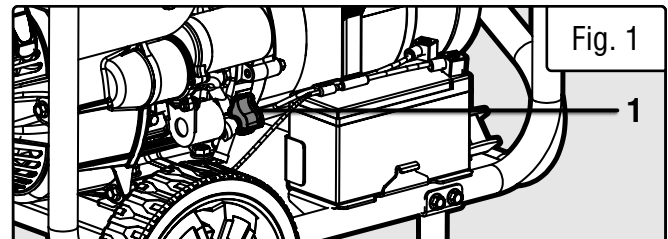

GENERATOR PREPARATION

STEP 1 - ADD / CHECK OIL (CONTINUED)

For subsequent operation, the oil level should be checked before each use, or after every 8 hours of operation. The generator is equipped with a low-oil sensor and will not start without a sufficient amount of oil.

To check oil level (before every subsequent start):

1. Place the generator on a level surface. Make sure the engine is off before adding or checking oil.
2. Remove and wipe the dipstick with a clean rag.
3. Insert the dipstick into the oil fill without screwing it in. Remove the dipstick to check the oil mark (Fig. 3).

If the oil mark covers less than one half of the dipstick, slowly add oil until the oil mark reaches to the top of the dipstick.

4. Wipe clean any oil leaks and firmly tighten the dipstick.

OIL LEVEL SHUTDOWN

To protect the unit from damage, the generator is equipped with a low-oil-pressure shutoff that will automatically stop the engine when the oil level is too low. The low oil alert light (Fig. 4) will turn ON to remind you that the engine oil level is low and needs to be refilled.

The oil level of the engine should be checked before each start to ensure that the engine crankcase contains sufficient lubricant.

TIP: Your WEN generator is compatible with the **WEN GNA273 Magnetic Oil Dipstick** (not included), available for purchase at wenproducts.com. The dipstick's industrial-strength magnetic tip will collect metal shavings from your generator's oil compartment to help preserve the engine and extend your generator's lifespan.

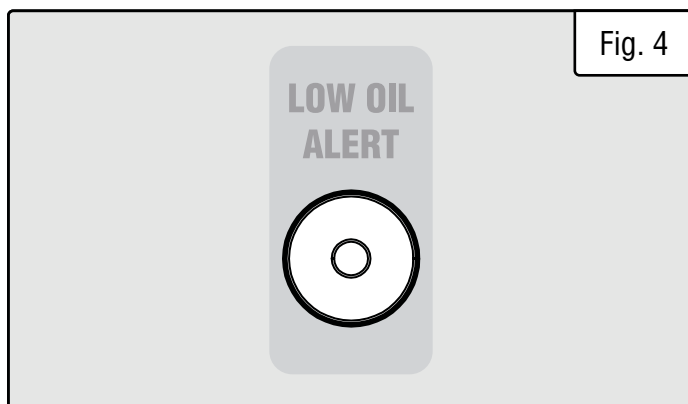
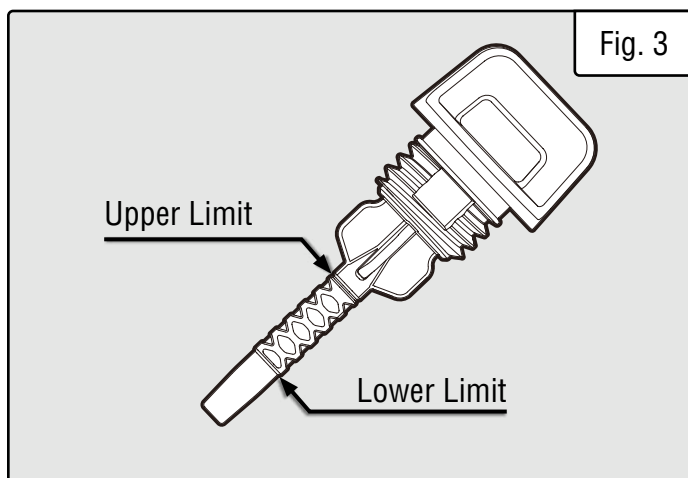

GENERATOR PREPARATION

STEP 2 - ADD / CHECK FUEL

FUEL OPTION A: GASOLINE

⚠ WARNING! RISK OF EXPLOSION. HIGHLY FLAMMABLE: This generator may emit highly flammable and explosive gasoline vapors, which can cause severe burns or even death, if ignited. A nearby open flame can lead to explosion even if not directly in contact with gasoline.

- Do not operate near open flame, heat, or any other ignition source. Do not smoke near the generator.
- Always operate on a firm, level surface.
- Always turn generator off before refueling. Allow generator to cool for at least 2 minutes before removing fuel cap. Loosen cap slowly to relieve pressure in tank.
- Do not overfill fuel tank. Gasoline may expand during operation. Do not fill to the top of the tank. Allow for expansion. Always check for spilled fuel before operating.
- If fuel spills, move the generator at least 30 feet away from the spill and wipe clean any spilled fuel before starting the engine.
- Empty fuel tank before storing or transporting the generator.

Use **ONLY** fresh (within 30 days from purchase), lead-free gasoline with a minimum of 87 octane rating. The generator performs best with ethanol-free gasoline. **DO NOT** use gasoline with over 10% ethanol. The capacity of the fuel tank is **6.70 US gallons (25.40 L)**. Do not mix oil with gasoline.

To add gasoline:

1. Make sure the generator is shut OFF and on a level surface. Unscrew the fuel cap (Fig. 5 - 1) and set it aside. The fuel cap may be tight and hard to unscrew.

2. Slowly add unleaded gasoline to the fuel tank. Be careful not to overfill.

NOTE: Do not fill the fuel tank to the very top. If you do so, gasoline will expand and spill during use, even with the fuel cap in place.

3. Reinstall fuel cap and wipe clean any spilled gasoline with a dry cloth.

To check fuel level:

Check the fuel gauge (Fig. 5 - 2) on top of the fuel tank. If the fuel level is low, refill the fuel tank before starting your generator for the next time.

IMPORTANT:

- Avoid getting dirt or water into the fuel tank.
- Keep gasoline away from sparks, open flames, pilot lights, heat, and other sources of ignition.
- Gasoline can age in the tank and make starting difficult. Never store the generator for more than 2 months with fuel in the tank.
- Never use an oil/gasoline mixture.
- Never use old gasoline.

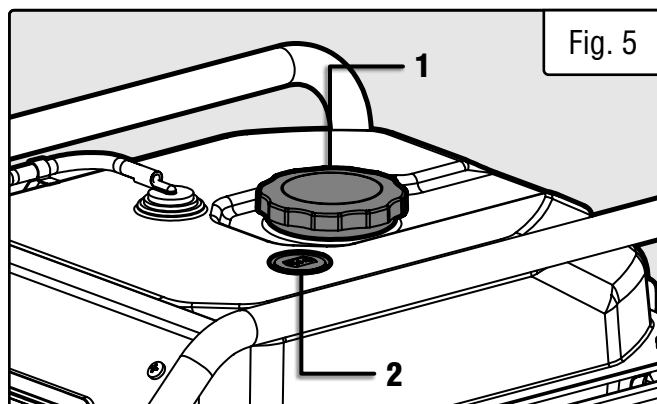

GENERATOR PREPARATION

FUEL OPTION B: LIQUID PETROLEUM GAS (LPG)

⚠ DANGER! Explosion and fire. LP vapors are extremely flammable and explosive. Do not use or store LP cylinder in a building, garage or enclosed area. Failure to do so will result in death or serious injury.

⚠ WARNING! Explosion and fire. The cylinder valve should be turned OFF (closed) when generator is not in use. Failure to do so could result in death or serious injury.

- Always keep the LPG cylinder in an upright position.
- When transporting and storing, keep cylinder secured in an upright position with cylinder valve turned off. Keep cylinders ventilated and away from heat when in a vehicle.
- Liquid Petroleum Gas (LPG) is highly flammable and explosive. Flammable gas under pressure can cause a fire or explosion if ignited.
- In any petroleum gas fire, flames should not be extinguished unless the fuel supply valve is turned OFF. If a fire is extinguished and a supply of fuel is not turned OFF, an explosion hazard could be created.
- RISK OF BURNS. Contact with liquid contents of cylinder will cause freeze burns to the skin. If liquid contents contacts skin or eyes, seek immediate medical attention.
- When exchanging LPG cylinders, be sure the cylinder valve is of the same type.

FUEL OPTION B: LIQUID PETROLEUM GAS (LPG) (CONT.)

- You can use LPG tanks with Type 1, right hand Acme threads with this generator. Verify that the qualification date on tank has not expired. Do not use rusted or damaged cylinders.
- All new cylinders must be purged of air and moisture prior to filling. Used cylinders that have not been plugged or kept closed must also be purged.
- The purging process should be done by the propane gas supplier. (Cylinders from an exchange supplier should have been purged and properly filled by supplier).

GENERATOR PREPARATION

To connect your generator to an LPG cylinder:

1. Take off the safety caps from the cylinder valve, generator-mounted regulator, and regulator connecting hose ends.
2. With the LPG tank closed, attach the first-stage regulator to the valve. Turn the regulator's plastic coupling right (clockwise) to tighten the assembly onto the LPG tank (Fig. 6).
3. Connect the other end of the hose to the generator's onboard regulator (Fig. 7 - 1) with a 3/4 in. (19mm) wrench (not supplied).
4. Turn the LPG tank valve ON and check for leaks by spraying soapy water to check the connections. If bubbles appear, become larger in size, or increase in number, a leak exists. This must be corrected before using the generator. Contact your local Independent Authorized Service Dealer (IASD) for assistance.

NOTE: You can use Teflon (or other tape) to help seal the connection between the regulator hose and the generator.

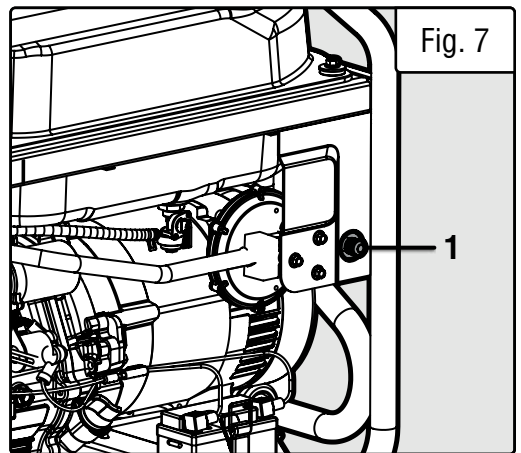
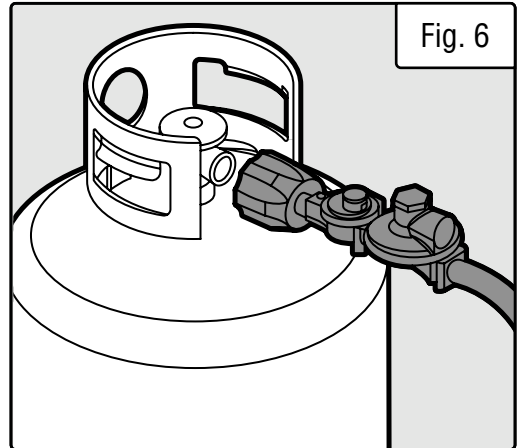

⚠ CAUTION! Always position the LPG cylinder so the connection between the valve and regulator won't cause sharp bends or kinks in hose.

⚠ WARNING! Risk of burns. Contact with liquid contents of cylinder will cause freeze burns to the skin. If liquid contents contacts skin or eyes, seek immediate medical attention.

⚠ WARNING! When transporting and storing, keep cylinder secured in an upright position with cylinder valve turned off. Keep cylinders ventilated and away from heat when in a vehicle.

GENERATOR PREPARATION

STEP 3 - CONNECTING THE BATTERY

⚠ WARNING! Use only genuine WEN batteries with your generator (**part no. DF8000X-065**). Use of other batteries may induce premature product failure and could pose a safety risk.

ABOUT THE BATTERY

1. The lithium-ion battery supplied with your generator is only partially charged, in order to maximize its service life. The battery may not have enough charge to start the engine during its first use. If this is the case, connect the battery according to the instructions below, and start the generator using the recoil starter, according to the instructions below. The battery will receive charge when the generator is running.

2. Lithium-ion batteries are subject to a natural aging process. The battery must be replaced at the latest when its capacity falls to just 80% of its capacity when new. Weakened cells in an aged battery are no longer capable of meeting the high power requirements needed for the proper operation of your generator, and therefore pose a safety risk.

3. **DO NOT INCINERATE BATTERY.** Do not throw the battery into an open fire as this poses a risk of explosion. Do not ignite the battery or expose it to fire.

4. **AVOID DAMAGE AND SHOCKS.** Immediately replace batteries that have been dropped from a height of more than one meter (3 feet) or those that have been exposed to violent shocks, even if the housing of the battery appears to be undamaged. The battery cells inside the battery may have suffered serious damage. In such instances, please read the waste disposal information on p. 31 for proper battery disposal.

5. **DO NOT CRUSH, DROP OR DAMAGE BATTERY.** Do not use the battery if it has sustained a sharp blow, been dropped, run over or has been damaged in any way (e.g. pierced with a nail, hit with a hammer, stepped on, etc.).

6. **DO NOT DISASSEMBLE.** Incorrect reassembly may pose a serious risk of electric shock, fire or exposure to toxic battery chemicals. If the battery or charger are damaged, call WEN customer service at 1-847-429-9263 for assistance.

7. **DO NOT SHORT CIRCUIT.** Batteries will short circuit if a metal object makes a connection between the positive and negative contacts on the battery. Do not place the battery near anything that may cause a short circuit, such as paper clips, coins, keys, screws, nails and other metallic objects. A short-circuited battery poses a risk of fire and severe personal injury.

NOTE: The safe temperature range for charging the battery is 25°F – 104°F. The generator is shipped with the lithium-ion battery's negative (-) terminal disconnected to maximize safety. To start the generator using electric start, the battery must be connected.

To connect the battery:

1. Connect the two ends of the quick connector on the battery (Fig. 8 - 1) to connect the battery to the generator's system. Make sure the battery is secured to the generator frame by the battery strap.

NOTE: The generator can be run with the battery disconnected or with no charge using the recoil starter. You may use either gasoline or LPG.

IMPORTANT: If you do not plan to use the generator for an extended period of time, we recommend **DISCONNECTING** the quick-connector. This will protect the battery from losing its charge. After disconnecting the quick-connector, cover the ends of the cable with an insulator such as electrical tape. Alternatively, you can use a trickle charger (not included) to maintain battery charge.

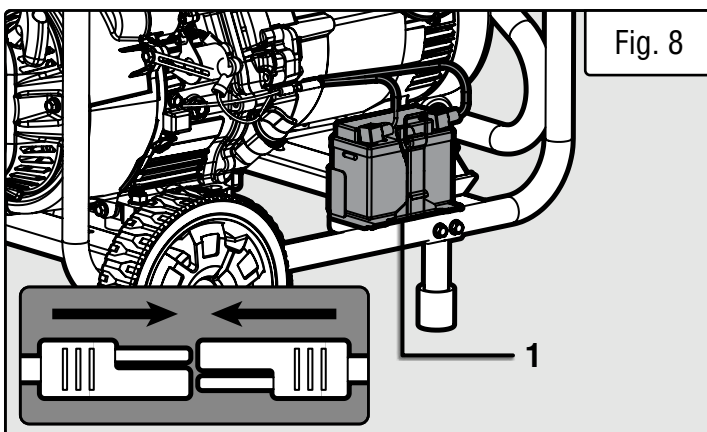

Fig. 8



For more information on your battery quick-connectors, scan the QR code or visit the link below:
<http://bit.ly/44sb6C2>

GENERATOR PREPARATION

STEP 4 - GROUND THE GENERATOR

To reduce the risk of electric shock and to maximize safety, the generator should be properly grounded.

Ground the generator by tightening the grounding nut (Fig. 9 - 1) on the front control panel against a grounding wire. A generally acceptable grounding wire is a No. 12 AWG (American Wire Gauge) stranded copper wire.

This grounding wire should be connected at the other end to a copper, brass, or steel grounding rod that is driven into the earth. Wire and grounding rods are not included with the generator.

NOTE: Grounding codes can vary by location. Contact a local electrician to check the area codes.

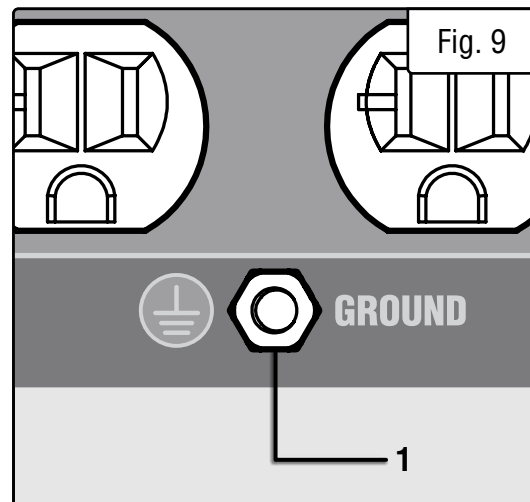

⚠ WARNING! Failure to properly ground the generator increases your risk of electric shock.

HIGH ALTITUDE OPERATION ABOVE 3000 FEET

The fuel system on this generator may be affected by operation at high altitudes. Proper operation can be ensured by installing an altitude kit at altitudes higher than 3000 feet above sea level. At elevations above 8000 feet, the engine may experience a decrease in performance, even with the proper altitude kit. Operating this generator without said kit may increase the engine's emissions and decrease both fuel economy and performance.

You can order the kit at wenproducts.com by searching part DF8000X-HA. There are two kits - one for altitudes between 3000 and 6000 feet (**part no. DF8000X-HA36**), and the other for altitudes from 6000 to 8000 feet (**part no. DF8000X-HA68**). This kit should be installed by a qualified mechanic. Refer to the instructions included with your altitude kit for more information about installation.

NOTE: The high altitude kit must be installed for operation above 3000 feet.

⚠ WARNING! To prevent serious injury from fire, follow the kit installation procedures in a well-ventilated area away from ignition sources. If the engine is hot from use, shut the engine off and wait for it to cool before proceeding. Do not smoke near the generator. Warranty will be void if adjustments are not made for high altitude use.

CAUTION: Engines with the high-altitude kit installed operated at lower altitudes could cause severe engine damage and affect emissions compliance. Be sure to uninstall the high altitude kit when operating at altitudes below 3000 feet.

After completing the above preparation, the generator is ready to be started.

STARTING YOUR GENERATOR

Before starting the generator, make sure you have read and performed the steps in the “Generator Preparation” section of this manual. If you are unsure about how to perform any of the steps in this manual please call **1-847-429-9263** M-F 8-5 CST for customer service.

DANGER! CARBON MONOXIDE

Using a generator indoors **CAN KILL YOU IN MINUTES**. Generator exhaust contains carbon monoxide (CO). This is a poison gas you cannot see or smell. If you can smell the generator exhaust, you are breathing CO. But even if you cannot smell the exhaust, you could be breathing CO.

NEVER use a generator inside homes, garages, crawl spaces, or other partially enclosed areas. Deadly levels of carbon monoxide can build up in these areas. Using a fan or opening windows and doors does NOT supply enough fresh air. **ONLY** use a generator outside and far away from windows, doors, and vents. These openings can pull in generator exhaust.

Even if you use a generator correctly, CO may leak into the home. **ALWAYS** use a battery-powered or battery-backup CO alarm in the home. If you start to feel sick, dizzy, or weak after the generator has been running, move to fresh air **RIGHT AWAY**. See a doctor. You may have carbon monoxide poisoning.

 **WARNING!** The exhaust from this product contains chemicals known to the State of California to cause cancer, birth defects, or other reproductive harm.

 **WARNING!** Do not operate generator near open flame or flammable materials. This generator may emit highly flammable and explosive gasoline vapors, which can cause severe burns or even death if ignited. A nearby open flame can lead to explosion even if it isn't directly in contact with gasoline. Do not smoke near the generator.

 **WARNING!** This generator produces powerful voltage, which can result in electrocution.

 **WARNING!** Do not use in rainy or wet conditions. Do not touch bare wires or receptacles (outlets). Do not allow children or non-qualified persons to operate.

 **WARNING!** Generator should only be connected to electrical devices, either directly or with an extension cord. **NEVER** connect to a building electrical system without a qualified electrician and connected to a transfer switch as a separately derived system. Such connections must comply with local electrical laws and codes. Failure to comply can create a back-feed, which may result in serious injury or death to utility workers.

To maximize safety, **ALWAYS** ground the generator before using it. See section “Ground the Generator”.

Use a ground fault circuit interrupter (GFCI) in highly conductive areas such as metal decking or steel work. GFCIs are available in-line with some extension cords.

CAUTION! Disconnect all electrical loads from the generator before attempting to start.

BEFORE STARTING THE GENERATOR

1. Verify that the generator is outside on a dry, level surface with at least two feet of clearance on all sides.
2. To maximize safety, check that the generator is properly grounded (see "GROUND THE GENERATOR").
3. Check that there is a sufficient level of oil in the crankcase. Add oil if necessary (see "ADD / CHECK OIL").
4. Make sure that there is enough gasoline in the fuel tank (or LPG in the LPG cylinder). Add fuel if necessary (see "ADD / CHECK FUEL").
5. Make sure that the battery is connected (see "CONNECTING THE BATTERY").
6. Make sure all electrical devices are unplugged from the generator during ignition otherwise it will be difficult for the engine to start.

STARTING YOUR GENERATOR

STARTING THE GENERATOR

1. To use gasoline, turn the fuel valve (Fig. 10 - 1) to the ON position. To use LPG, make sure all of the LPG connectors and hoses are well connected and sealed. Turn the fuel valve to the OFF position, then open the LPG tank valve.

2a. Turn the fuel selector switch on the panel to the appropriate fuel (gasoline or LPG).

2b. If using LPG, prime the engine. To do this, move the choke lever (Fig. 11 - 1) to the CLOSED position, then gently pull the recoil starter (Fig. 11 - 2) 1 - 3 times.

3a. If using gasoline, turn the choke lever (Fig. 11 - 1) to the CLOSED position.

3b. If using LPG, turn the choke lever (Fig. 11 - 1) to the OPEN position.

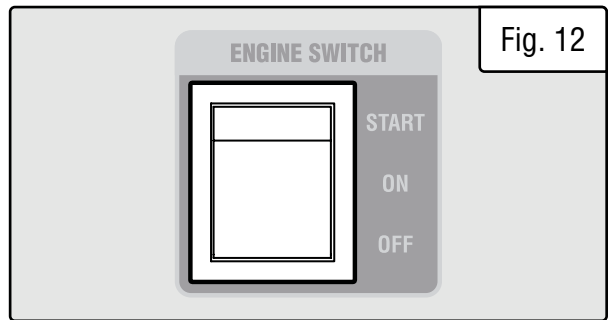
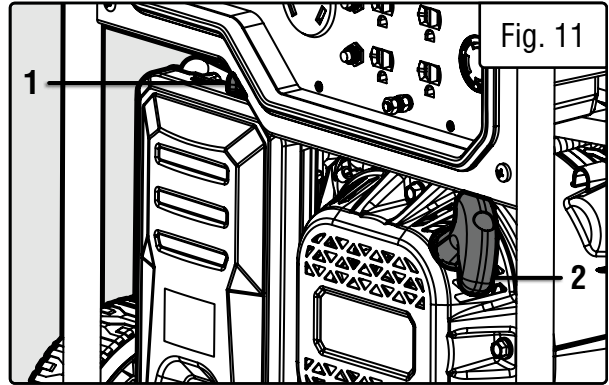
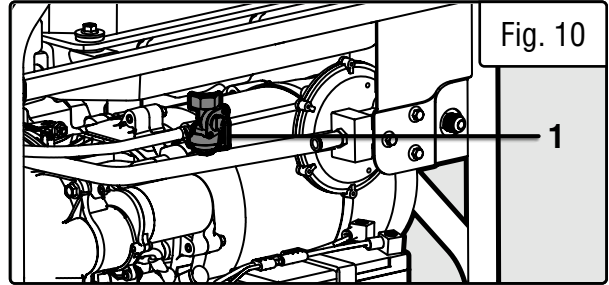

Option A: Electric Start

4. Push the engine switch (Fig. 12) to the START position and hold for 2-3 seconds until the engine starts, then release.

NOTE: The battery is shipped partially charged, in order to maximize its service life, and may not have enough charge to start the engine during the first use of the generator. If you have trouble starting the generator the first time using electric start, use the pull start option and allow the generator to run for a few hours to charge the battery.

Option B: Pull Start

4a. Push the engine switch (Fig. 12) to the ON position.

4b. Place one hand on the generator to hold it in place, and pull on the recoil starter handle (Fig. 11 - 2) slowly until a slight resistance is felt. Then pull quickly to start the engine. Return cord gently into the machine. Never allow the cord to snap back.

NOTE: If engine fails to start, repeat step 3.

5. Once the engine starts, turn the choke lever to OPEN.

6. Allow the generator to run for several minutes before attempting to connect any electrical devices. This allows the generator to stabilize its speed and temperature.

NOTE: If you have repeated failed attempts to start the engine, please consult the troubleshooting guide. If problems persist, please call please call **1-847-429-9263** M-F 8-5 CST.

ENGINE BREAK-IN PROCEDURE

The procedure below should be followed when you receive your generator in order to prolong the engine's service life. This procedure helps to seat the piston rings properly in the cylinder, and will reduce overall wear on the engine.

For the first 8 hours of operation, vary the load, but keep it at or below 50% of the generator's rated wattage, if possible. If your generator is equipped with an Eco-mode switch (only applicable for certain inverter generators), engage Eco-mode periodically during the first 8 hours. After the first 8 hours, change the oil, then change it again after the first 25 hours. You may run the generator at full load after the 8-hour oil change. Refer to the Recommended Maintenance Schedule in Table 4 for the full maintenance schedule.

USING YOUR GENERATOR

CALCULATING THE WATTAGE OF YOUR DEVICE(S)

Connect electrical devices running on AC current according to their wattage requirements. Calculate the total running wattage and starting wattage of the device(s) you wish to connect, and **MAKE SURE** that they are within the capacity of your generator and the capacity of each individual outlet.

Generator Wattage Capacity	Generator Running (Rated) Watts	Generator Starting (Surge) Watts
	Gasoline: 6500W	Gasoline: 8000W
	LPG: 5850W	LPG: 7200W
	<p>What this means: The generator can produce a maximum of 6500W/5850W on a continuous basis to supply ongoing power to your electronic devices.</p> <p>NOTE: Also check the rated amperage for each outlet and make sure not to overload the individual outlets.</p>	<p>What this means: Some devices such as box fans require short bursts of extra power in addition to the rated wattage listed by the device to start their motors.</p> <p>The generator can produce a maximum wattage of 8000W/7200W for a short period of time (seconds) to cover the extra starting power required by your electronic devices.</p>
Electronic Device Wattage Calculation	<p>Find the wattage information of each device you plan to connect. The information should be listed on the device or in its instruction manual.</p> <p style="text-align: center;">The wattage can be calculated using this equation: Watts = Volts x Amperes</p>	
	<p>To calculate the total running watts of your devices:</p> <p>+ Add up the running wattages of all the device(s) you plan to connect</p> <p>= The total running wattage</p> <p>This wattage should NOT exceed the running wattage of 6500W/5850W.</p> <p>It is recommended to maintain a load at or below 5850W/5265W (90% of the rated output) to ensure steady voltage output and to prolong the generator's lifespan.</p>	<p>To calculate the total starting watts of your devices:</p> <p>+ Add up the total running wattage of all the device(s) you plan to connect</p> <p>+ Add the single highest ADDITIONAL starting wattage out of the device(s) you plan to connect</p> <p>= The total surge (starting) wattage</p> <p>This wattage should NOT exceed the starting wattage of 8000W/7200W.</p>
	<p>If any of either of the total calculated running watts or starting watts is higher than the capacity of your generator, adjust the load until both wattage requirements are met. Otherwise you will overload the generator, and cause damage to the engine and your electrical device(s).</p>	

Table 1 - How to Calculate Wattages

USING YOUR GENERATOR

CALCULATING THE WATTAGE OF YOUR DEVICE(S) - CONTINUED

The chart below serves as a reference for the estimated wattage requirements of common electrical devices. However, do not solely rely on this chart - all electronics and appliances are built differently. Always check the wattage listed on the electrical device before consulting this chart.

Tool or Appliance	Rated (Running) Watts	Surge (Starting) Watts
Electric Water Heater (40 Gal)	4000	0
Hot Plate	2500	0
Saw - Radial Arm	2000	2000
Electric Stove (Each Element)	1500-2800	0
Saw - Circular	1500	1500
Air Compressor (1 HP)	1500	3000
Window Air Conditioner	1200	1800
Saw - Miter	1200	1200
Microwave	1000	0
Well Water Pump	1000	1000
Sump Pump	800	1200
Refrigerator Freezer	800	1200
Furnace Blower	800	1300
Computer	800	0
Electric Drill	600	900
Television	500	0
Deep Freezer	500	500
Garage Door Opener	480	0
Stereo	400	0
Box Fan	300	600
Clock Radio	300	0
Security System	180	0
Dvd Player / VCR	100	0
Common Light Bulb	75	0

Table 2 - Estimated Wattages of Common Electrical Appliances

NOTE: Become familiar with the functions and capacity of each component on the control panel before connecting electrical devices. See page 11 for more information about the components of the control panel. Do not overload generator or individual panel receptacles. Do not connect 50Hz or 3-phase loads to the generator.

USING YOUR GENERATOR

CONNECTING ELECTRICAL DEVICES

When the rated wattage requirement of each electrical device has been determined, add these numbers to find the total rated wattage needed. If this number exceeds the rated wattage (6500W) of the generator, DO NOT connect all these devices. Select a combination of electrical devices with a total rated wattage lower than or equal to the rated wattage of the generator.

⚠ CAUTION! Become familiar with the markings on the control panel before connecting electrical devices. Do not connect 3-phase or 50Hz loads to the generator.

1. Before connecting electrical devices, allow the generator to run for a few minutes to stabilize the speed and voltage output.
2. Make sure that all devices are turned off. Start plugging in each electric device, from the highest wattage to the lowest. Check the power indicator light (green) to ensure the generator is producing power.
3. Do not overload the generator or individual panel receptacles. If an overload occurs, one or more circuit breakers will trip. Unplug all electrical devices, then press the circuit breaker to reset it. If it will not reset, wait a few minutes for it to cool down. Check the total wattage of the devices and reduce the load if it exceeds the capacity of the generator. Then, plug the loads back in one by one.

NOTE: If the reset button or circuit breaker does not reset, wait several minutes and try again. If problem still persists, please call **1-847-429-9263** M-F 8-5 CST, or email **techsupport@wenproducts.com**.

SWITCHING FUELS

To maximize your generator's lifespan, we recommend removing all loads from the generator before switching between gasoline and LPG. If this is not possible, reduce loads as much as possible in order to ensure a smooth switch. Your generator is rated to handle a higher load when running on gasoline than on LPG, so keep this in mind when planning your fuel usage. To switch fuels:

1. Make sure you have enough gasoline or propane. If switching to propane, make sure the propane regulator and hose are securely attached to the propane cylinder and the propane inlet on the generator, and that the propane cylinder valve is turned ON.
2. Turn the fuel selector switch (Fig. 13) to the desired fuel source.

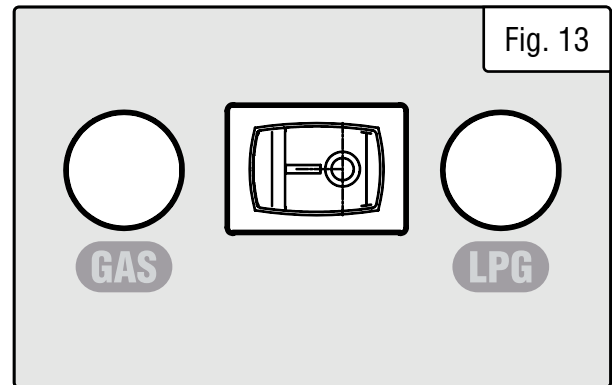

USING YOUR GENERATOR

SOME NOTES ABOUT POWER CORDS

Long or thin cords can drain the power provided to an electrical device by the generator. When using such cords, allow for a slightly higher rated wattage requirement by the electrical device.

Device Requirements			Max. Cord Length (ft) by Wire Gauge				
Amps	Watts (120V)	Watts (240V)	#8 wire	#10 wire	#12 wire	#14 wire	#16 wire
2.5	300	600	NR	NR	NR	375	250
5	600	1200	NR	NR	300	200	125
7.5	900	1800	NR	350	200	125	100
10	1200	2400	NR	250	150	100	50
15	1800	3600	NR	150	100	65	NR
20	2400	4800	175	125	75	50	NR
25	3000	6000	150	100	60	NR	NR
30	3600	7200	125	65	NR	NR	NR
40	4800	9600	90	NR	NR	NR	NR

*NR = Not Recommended

Table 3 - Power Cord Requirement Guide

⚠ WARNING! Generator should **only** be connected to electrical devices, either directly or with an extension cord. NEVER CONNECT TO A BUILDING ELECTRICAL SYSTEM without a qualified electrician and connected to a transfer switch as a separately derived system. Such connections must comply with local electrical laws and codes. Failure to comply can create a back-feed, which may result in serious injury or death to utility workers.

NOTE: For power outages, permanently installed, stationary generators are better suited for providing backup power to your home. Even a properly connected portable generator can become overloaded. This may result in overheating or stressing the machine's components, possibly leading to generator failure.

CIRCUIT BREAKERS (FIG. 14)

The 30A circuit breaker protects the NEMA TT-30R outlet. The 20A circuit breakers protect the NEMA 5-20R outlets. The 25A circuit breakers each protect one leg of the NEMA L14-30R outlet. The circuit breakers will activate when the outlets exceed the indicated amperage. When the circuit breaker activates, turn off and disconnect the device from its respective outlet and press the circuit breaker to reset.

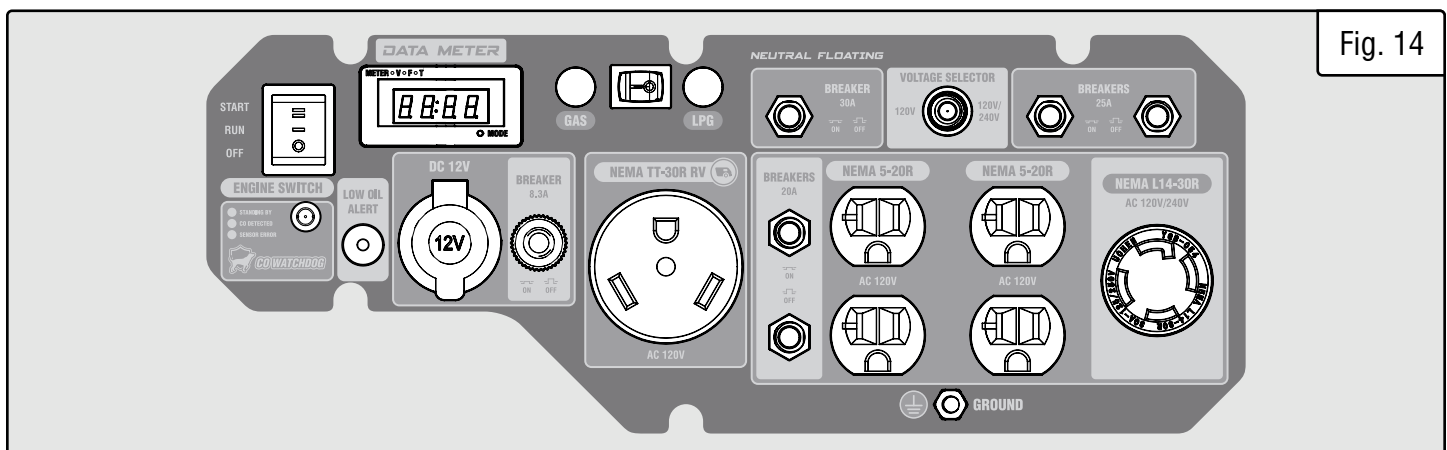

Fig. 14

USING YOUR GENERATOR

CO SENSOR INFORMATION

The CO Watchdog carbon monoxide monitoring system (Fig. 15 - 1) measures the accumulation of poisonous CO gas while the generator is running. If the level of CO gas gets too high, the CO Watchdog system will automatically shut down the generator. **This system is not a substitute for an indoor CO alarm.**

Whenever the CO Watchdog system shuts down the generator, the LED on the generator control panel (Fig. 15 - 1) will **blink red** for at least 5 minutes after the generator is shut down. **If you notice that the LED is blinking red, vacate the area immediately.** Go to an open, outdoor area. Ventilate the area around the generator thoroughly before returning. Let the generator stay shut down for a few minutes before restarting the engine. This should allow carbon monoxide to dissipate from the area. If you restart the generator and the CO Watchdog detects that CO levels are still too high, it will shut down the generator again. If CO levels are low enough, the generator will run normally.

Ensure that the generator is located in an open outdoor area, with the exhaust pointing away from occupied structures, and pointing away from the prevailing winds, such that those winds do not blow engine exhaust towards the sensor module. If anyone experiences dizziness, headaches, nausea, fatigue, or other symptoms of CO poisoning, get to fresh air immediately and seek the attention of a qualified medical professional. Follow all other directions in this manual regarding the connection and disconnection of electrical devices when starting or shutting down the generator.

When starting the generator, the CO Watchdog LED on the panel may flash. This indicates that the system is running a self-test procedure, and does not indicate a problem.

If the CO Watchdog LED on the panel is **yellow**, a system error has occurred, or the CO sensor has reached the end of its life. Contact WEN customer service (**1-847-429-9263**, M – F 8 – 5 CST, or techsupport@wenproducts.com) for assistance.

When operating your generator, please note the following:

- The CO Watchdog does not discriminate in its input; any source of carbon monoxide in the area around the generator could cause it to activate. If the CO Watchdog LED is blinking red, safety measures should be taken immediately.
- Tampering with, disconnecting, or bypassing the CO sensor could cause hazardous conditions, including but not necessarily limited to injury or death, and will void your warranty. The generator will not run with the CO sensor disconnected or bypassed, or if the CO sensor indicates an error.
- The CO sensor has a lifetime of about 7 years, and is capable of monitoring its lifetime. If your generator shows an error light several years after purchase, it may be time to replace the CO sensor. Contact WEN customer service for assistance.

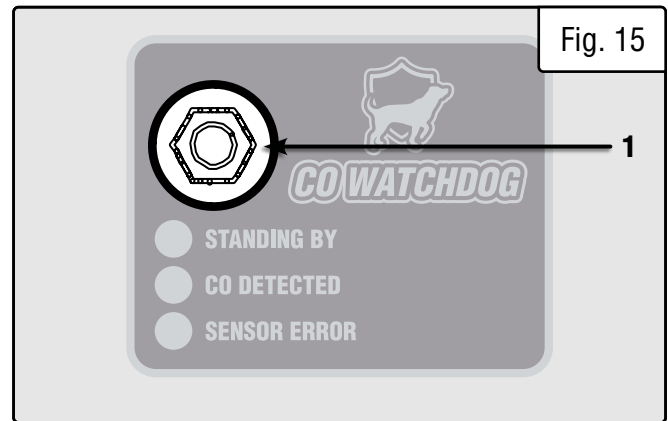

NOTE: if the generator is oriented so that the engine exhaust is blown towards the CO sensor, the generator may shut down.

SHUTTING OFF YOUR GENERATOR

⚠ CAUTION! Unplugging running devices can cause damage to the generator. Never stop the engine with electrical devices connected and running.

OPTION 1: AUTOMATIC FUEL SHUTOFF (GASOLINE ONLY)

Your generator is equipped with automatic fuel shutoff. This feature turns off the flow of fuel, allowing for the generator to use up the remaining fuel from the carburetor before turning off. This prolongs the lifespan of the generator by preventing build-up and blockages caused by stagnant fuel inside of a carburetor.

1. Turn off all electrical devices prior to unplugging them from the generator. Unplugging running devices can cause damage to the generator.

2. Allow the generator to run at no load for a few minutes to stabilize the internal temperatures.

3. Turn the fuel valve (Fig. 16 - 1) to the OFF position.

4. The engine will continue to run until the majority of the fuel in the carburetor is consumed, which takes a few minutes. It will then shut off automatically. This feature helps to prevent the carburetor from being clogged by stale fuel, extending your generator's lifespan.

6. Push the engine switch (Fig. 17) to the OFF position.

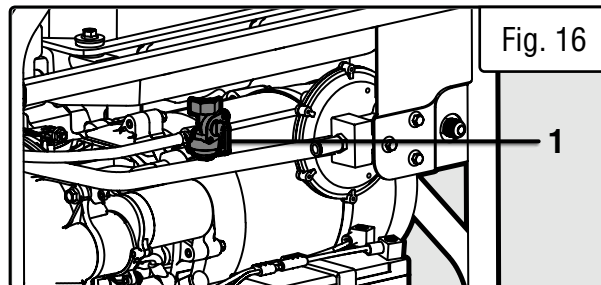

Fig. 16

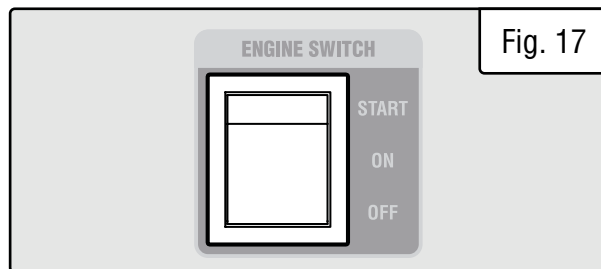

Fig. 17

OPTION 2: MANUAL SHUTOFF

In case you are in a hurry and do not want to wait for the generator to automatically shut down, the manual shutoff feature is available. However, this method will leave stagnant fuel in the carburetor, possibly causing blockages, a shortened lifespan, and other maintenance issues. If this approach is frequently taken, make sure to drain your carburetor before any long storage periods.

1. Turn off all electrical devices prior to unplugging them from the generator. Unplugging running devices can cause damage to the generator.

2. Push the engine switch to the OFF position.

OPTION 3: LPG SHUTOFF

1. Turn off all electrical devices prior to unplugging them from the generator. Unplugging running devices can cause damage to the generator. Never start or stop the generator with electrical devices plugged in or turned on.

2. Let the engine run at no-load for several minutes to stabilize internal temperatures of the engine and generator.

3. Make sure the fuel valve is OFF and then turn the engine switch to the OFF position.

IMPORTANT: Always ensure that the fuel valve and the engine switch are in the OFF position when the generator is not in use.

⚠ WARNING! Allow the generator to cool down before touching areas that become hot during use.

CAUTION: Allowing gasoline to sit in the fuel tank for long periods of time can make it difficult to start the generator in the future. Never store the generator for extended periods of time (over 2 months) with fuel in the fuel tank. Refer to "Storing the Generator."

MAINTENANCE

Proper routine maintenance of the generator will help prolong the life of the machine. Please perform maintenance checks and operations according to the schedule in Table 4.

⚠ CAUTION! Never perform maintenance operations while the generator is running. Before maintaining or servicing the generator, turn OFF the generator, disconnect all devices and allow the generator to cool down.

If there are any questions about the maintenance procedures listed in this manual, please call **1-847-429-9263** M-F 8-5 CST or email techsupport@wenproducts.com.

Recommended Maintenance Schedule		Every 8 Hours or Daily	Every 25 Hours	Every 3 Months or 50 Hours	Every 6 Months or 100 Hours	Before Storage	As Necessary
Engine Oil	Check Level	x					
	Replace	x**	x**	x*			x
Air Filter	Check			x*			
	Clean			x*			
Spark Plug	Check/Clean/Regap				x		
	Change				x		x
Fuel	Check Level	x					
	Drain					x	x
Carburetor	Drain	x					x
Spark Arrestor	Check/Clean				x		

* Clean/change more often under dusty conditions or operating under heavy load. Table 4 - Recommended Maintenance Schedule

** Change the oil after the first 8 hours of operation, after the first 25 hours of operation, and every 50 hours after that.

IMPORTANT GENERATOR MAINTENANCE TIPS:

- Drain your carburetor after each use and before storage to prevent it from clogging.
- Do not store the generator with fuel inside the tank for more than 2 months - the fuel will go bad.
- Run the generator for at least 20 minutes every month to charge the battery and maximize lifespan.

CLEANING THE GENERATOR

Keep the generator clean to prevent improper operation or machine damage from dirt and debris. Inspect all ventilation openings on the generator. These openings must be kept clean and unobstructed. If the generator becomes dirty, use a damp cloth to wipe exterior surfaces. Use a soft bristle brush to loosen dirt and oil and use a vacuum to pick up loose dirt. Use low pressure air (not to exceed 25 PSI) to blow away dirt.

⚠ CAUTION! Never clean the generator when it is running! Never clean with a bucket of water or a hose. Water can get inside the working parts of the generator and cause corrosion or a short circuit.

NOTE: Failure to properly maintain the generator will void the warranty.

MAINTENANCE

CLEANING THE GENERATOR

Keep the generator clean to prevent improper operation or machine damage from dirt and debris. Inspect all ventilation openings on the generator. These openings must be kept clean and unobstructed.

If the generator becomes dirty, use a damp cloth to wipe exterior surfaces. Use a soft bristle brush to loosen dirt and oil and use a vacuum to pick up loose dirt. Use low pressure air (not to exceed 25 PSI) to blow away dirt.

⚠ WARNING! Never clean the generator when it is running! Never clean with a bucket of water or a hose. Water can get inside the working parts of the generator and cause corrosion or a short circuit.

CHECKING / ADDING OIL

Check the oil level before each use and every 8 hours of operation (refer to Table 4).

The oil capacity of the generator engine is **30.4 fl. oz. (0.90 L)**. Add oil when the oil level is low. For proper type and weight of oil refer to “add oil” portion of the “Generator Preparation” section. This is a critical step for proper engine starting. The generator is equipped with a with low-oil shut down to protect it from running without oil.

To check the oil level and add oil:

1. Make sure the generator is on a level surface. Do not tilt the generator, as oil will flow into engine areas and cause damage. Keep generator level!
2. Remove the dipstick and wipe it with a clean rag.
3. Insert the dipstick into the oil fill opening without screwing in. Remove the dipstick to check the oil mark (Fig. 18). Add oil if the oil mark covers less than one half of the dipstick.
4. Using a funnel or appropriate dispenser, slowly add more oil. Repeat the step above until the oil mark reaches the top of the dipstick. Do not over fill.
5. Reinstall dipstick and wipe clean any spilled oil with a rag.

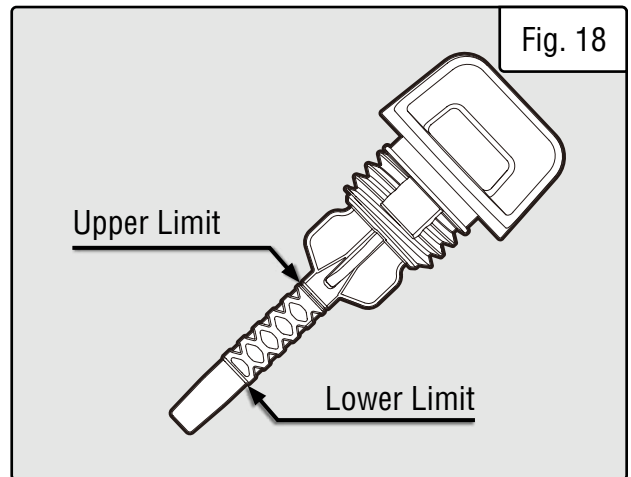

DRAINING THE CARBURETOR

We recommend draining the carburetor after every use and before storing the generator. Draining the carburetor can prevent the fuel from clogging up the carburetor; a clogged carburetor can prevent the generator from starting.

1. With the help of another person, place the generator on an elevated platform such as a table or desk.

2. Make sure that the engine switch is pressed to OFF and the fuel valve is in the OFF position. This will allow only the fuel left inside the carburetor to be drained out.

3. The carburetor (Fig. 19 - 1) can be accessed on the left of the generator, right behind the air filter.

4. Prepare an approved gasoline-storage container and a funnel.

5. Open up the carburetor drain screw (Fig. 17 - 2) with a Phillips-head screwdriver and drain out any gasoline that has built up inside the carburetor through the included funnel into the approved gasoline-storage container.

6. Once the fuel has drained, tighten the drain screw with the screwdriver.

NOTE: Make sure to drain your carburetor before storing the generator for long periods of time.

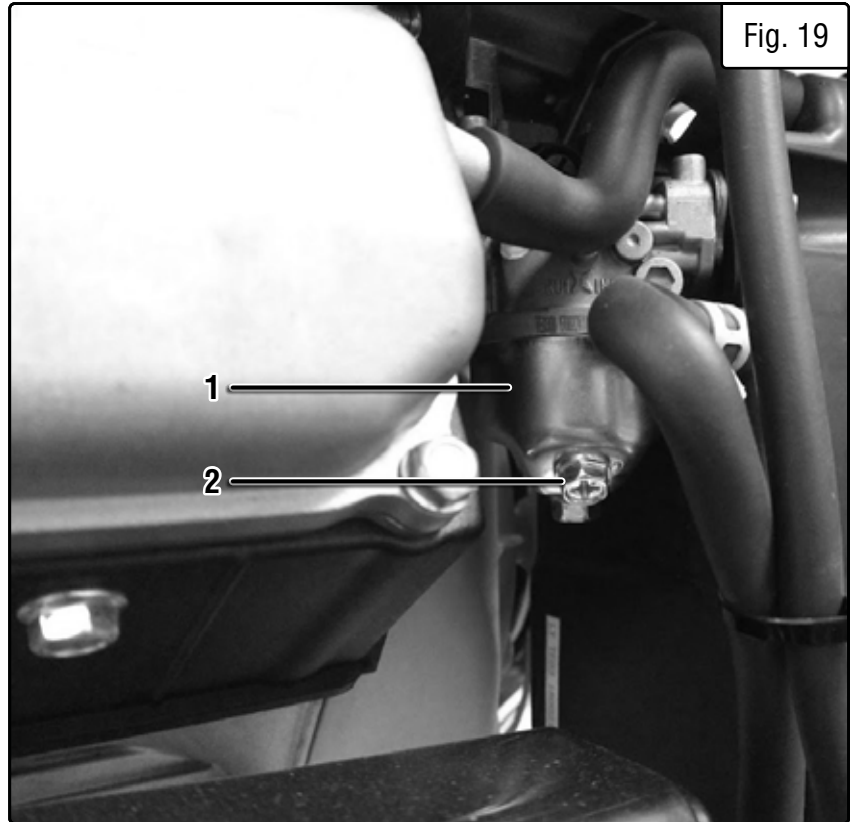

AIR FILTER MAINTENANCE

Check every 50 hours of operation (refer to Table 4 - Recommended Maintenance Schedule).

Routine maintenance of the air filter helps maintain proper airflow to the carburetor. Occasionally check that the air cleaner is free of excessive dirt.

To inspect and clean the air filter:

1. Remove the air filter cover (Fig. 20 - 1) by unscrewing the cover lock knob (Fig. 20 - 2) at the bottom of the air filter cover.

2. Remove the foam, sponge-like air filter element from the casing. Wipe excessive oil and any dirt from inside of the air filter casing.

3. Check the foam, sponge-like air filter element.

a) **Good elements** can be washed in soapy water. Dry the element in clean cloth (do not twist it). Add a few drops of engine oil to the air filter element and spread it evenly. A small amount of oil left in the element is normal and necessary for the engine to work properly.

b) **Damaged elements** should be replaced with a new one. Replacement air filters can be purchased from wenproducts.com by searching **part number DF8000X-137**.

4. Reinstall the air filter element and air filter cover.

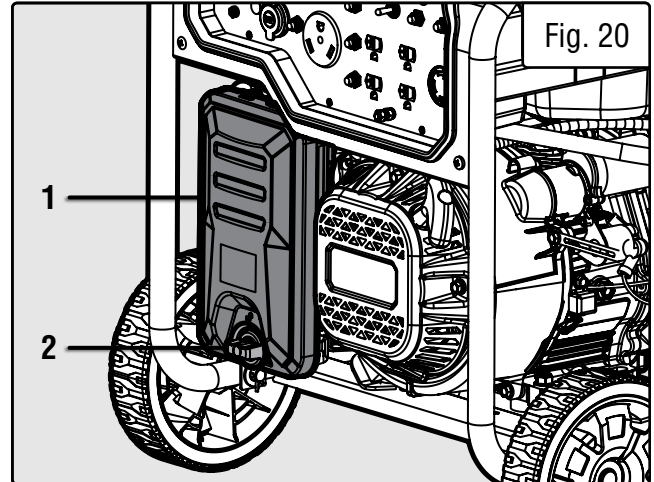

⚠ WARNING! Running the engine with a dirty, damaged or missing air filter element can result in danger to the operator and cause the engine to wear out prematurely.

SPARK ARRESTOR MAINTENANCE

Inspect and clean the spark arrestor every 100 hours of operation. The spark arrestor is located outside the muffler, which gets very hot during operation. Allow the engine to cool completely before servicing the spark arrestor. To inspect and clean the spark arrestor:

1. Remove the two Phillips-head screws that secure the spark arrestor to the muffler (Fig. 21 - 1).

2. Remove the spark arrestor screen.

3. Carefully clean and remove the carbon deposits from the spark arrestor screen with a wire brush. Replace the spark arrestor if it is damaged (replacement spark arrestors can be purchased from wenproducts.com by searching the **part no. DF8000X-027.1**).

4. Reinstall the spark arrestor in the muffler and secure it in place with the screws.

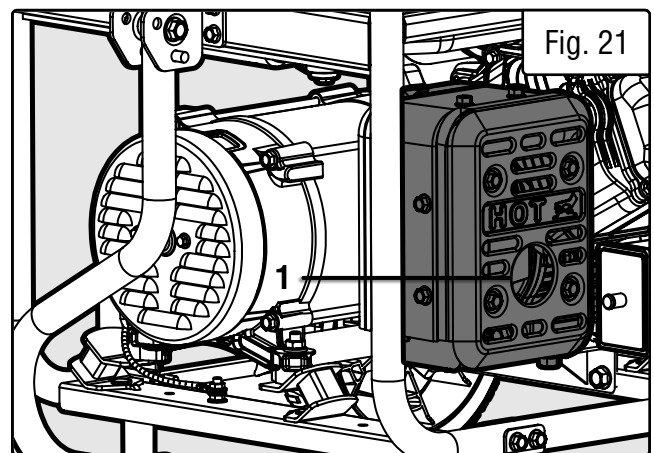

SPARK PLUG MAINTENANCE

Refer to Recommended Maintenance Schedule in Table 4 for maintaining the spark plug. The spark plug is important for proper engine operation. Check the spark plug regularly to maintain proper engine operation. A good spark plug should be intact, free of deposits, and properly gapped.

To inspect or replace the spark plug:

1. Gently pull on the spark plug boot (Fig. 22 - 1) to remove it. Be careful not to tear any insulation or wire.

2. Use the included spark plug socket (Fig. 23) to unscrew and then carefully remove the spark plug from the engine.

TIP: There is limited space for the wrench to turn. Use both rows of holes in the spark plug wrench to gain leverage to loosen the plug.

3. Visually inspect the spark plug. If it is cracked or chipped, or if the electrodes are worn or burned, discard it and replace with a new spark plug.

We recommend replacing with a Torch F7RTC (NGK BPR7ES) spark plug (**part no. DF8000X-122**), available for purchase at wenproducts.com.

4. If re-using the spark plug, use a wire brush to clean any dirt from around the spark plug base, then re-gap the spark plug.

5. Measure the plug gap with a spark plug gap gauge. The gap should be 0.028 in. - 0.031 in. (0.7mm - 0.8mm) (Fig. 24). Carefully adjust the gap if necessary.

6. Screw the spark plug back into the spark plug hole using the spark plug wrench. Do not over-tighten spark plug. Recommended tightening of spark plug is 20 - 22 ft-lbs (27 - 30 Nm).

7. Reinstall the spark plug boot, spark plug rubber cover, and service panel.

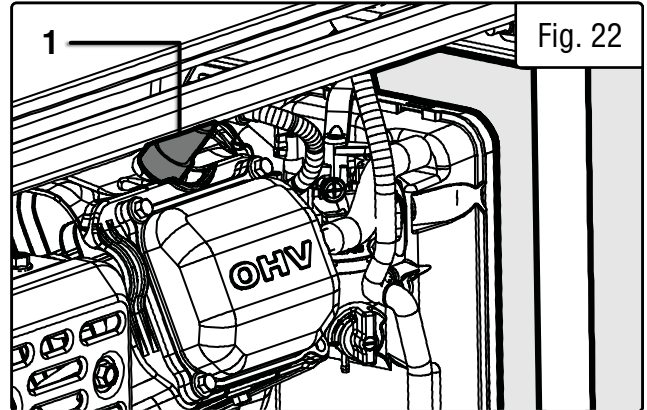

Fig. 22

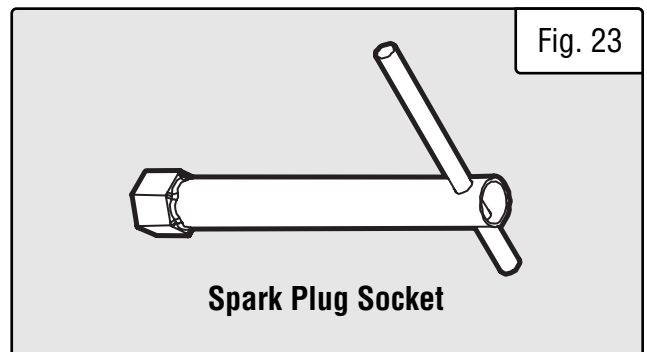

Fig. 23

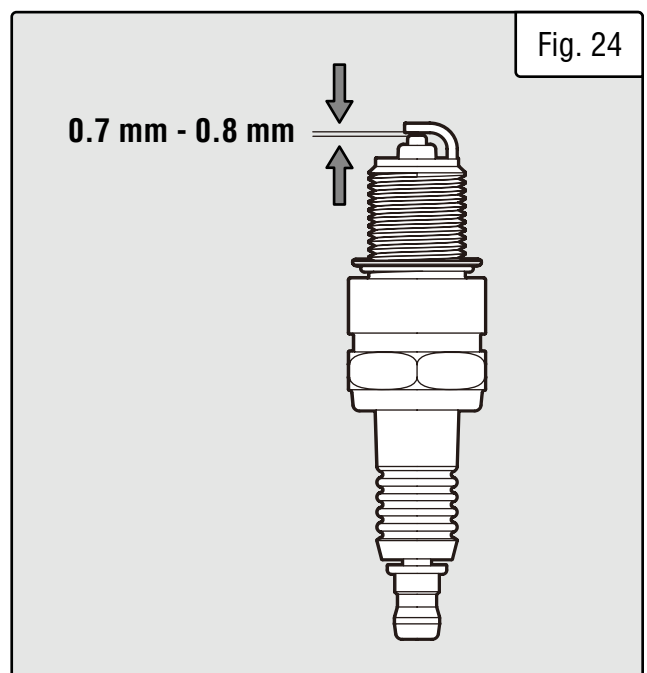

Fig. 24

DRAINING / CHANGING OIL

Change the oil according to the Recommended Maintenance Schedule in Table 4. Change the oil MORE OFTEN if operating under heavy load or high ambient temperatures. It is also necessary to drain the oil from the crankcase if it has become contaminated with water or dirt. Changing the oil when the engine is warm allows for more-complete drainage.

To change engine oil:

1. With the help of another person, place the generator on an elevated platform such as table or workbench.

NOTE: To avoid possible gasoline spills from the carburetor bowl, drain the carburetor before draining oil.

2. Prepare an approved oil-storage container and place it below the oil drainage bolt (Fig. 25 - 1) to catch oil as it drains.

4. Use a 10mm socket to loosen and remove the oil drainage bolt, and allow oil to drain from the engine completely.

5. Replace and tighten the oil drainage bolt after the oil has drained.

NOTE: Never dispose of used engine oil in the trash or down a drain. Please call a local recycling center or auto garage to arrange proper oil disposal.

6. Unscrew the oil dipstick. Using a funnel or appropriate dispenser, add 30.4 fl. oz. (0.90 L) of clean engine oil into the oil fill. Check the oil level periodically using the dipstick. Do not over fill.

TIP: Your WEN generator is compatible with the **WEN GNA273 Magnetic Oil Dipstick** (not included), available for purchase at wenproducts.com. The dipstick's industrial-strength magnetic tip will collect metal shavings from your generator's oil compartment to help preserve the engine and extend your generator's lifespan.

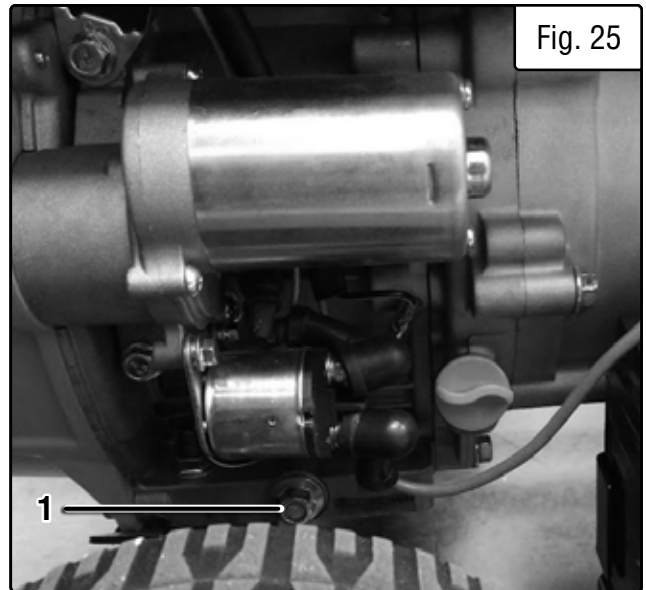

DRAINING THE FUEL TANK

Drain and clean the fuel tank each year, or before storing the generator for longer than two months.

To drain the fuel tank and carburetor:

1. Locate the carburetor (Fig. 26 - 1). It can be accessed on the back of the generator, right beside the air filter.
2. Prepare an approved gasoline-storage container and a funnel.
3. Remove the fuel cap (Fig. 27 - 1) and turn the fuel valve (Fig. 28 - 1) ON.
4. Open up the carburetor drain screw (Fig. 26 - 2) with a Phillips screwdriver. Fuel will start draining from the carburetor and fuel tank through the funnel.

NOTE: The draining process may take a few hours, depending on the amount of fuel in your gas tank.

5. Once fuel is completely drained from the tank, reinstall the fuel cap and turn the fuel valve (Fig. 28 - 1) OFF. Tighten the drain screw with the screwdriver.

6. Start and run the generator until the fuel runs out.

7. Store the emptied gasoline in a suitable place. DO NOT store flammable materials near the gasoline.

CAUTION: Store the emptied gasoline in a suitable place. Never store fuel for more than 2 months.

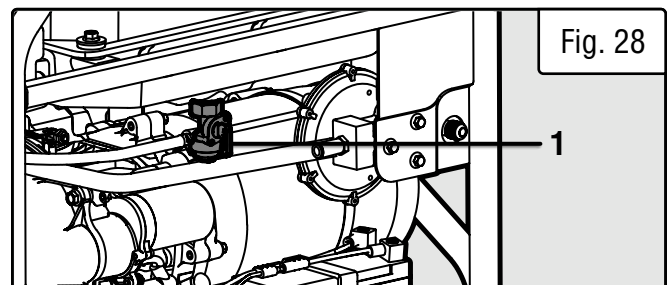
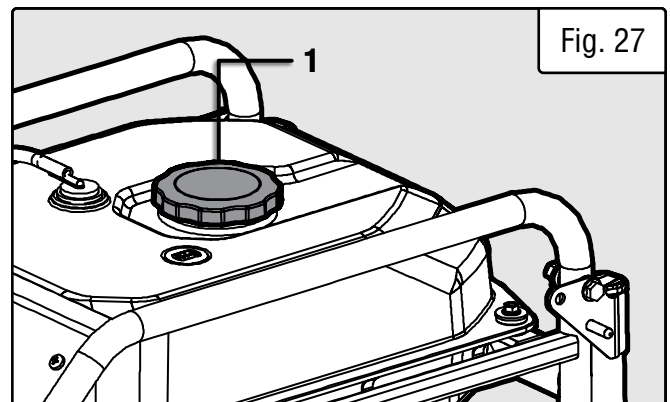
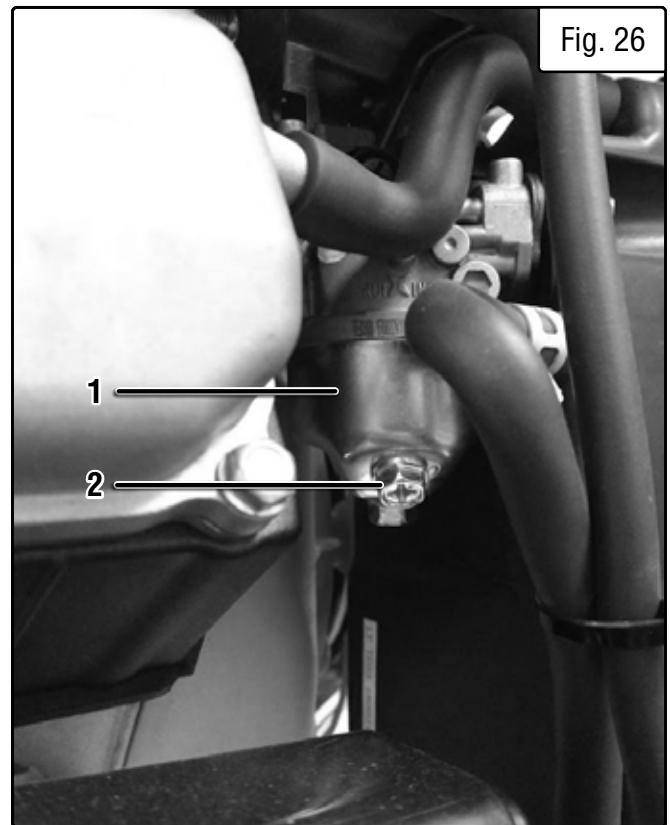

MAINTENANCE

BATTERY MAINTENANCE/STORAGE

The battery will receive charge when the engine is running. Remember to run the generator once a month for 20-30 minutes to charge the battery. A charged battery will allow you to start the generator using the electric start switch during your next time of need. If the battery is out of charge, you may start the generator using the recoil starter. If the generator is not used for a long period, it is recommended to disconnect the quick-connector from the battery to protect it from losing charge.

TIP: You can also connect the battery to an automatic trickle charger to keep the battery charged. If using a trickle-charger, charge the battery at room temperature.

Lithium-ion batteries can be damaged or suffer a shortened lifespan if they are charged in very cold temperatures (below freezing). If you expect to store the generator in temperatures below 25°F (-5°C), we recommend removing the battery from the generator and storing it indoors. If using the generator in temperatures below 25°F (-5°C), we recommend running the generator for at least 15 minutes with the battery removed, or the quick-connector cable disconnected and covered with the rubber sheath, and then connecting the battery. This will allow the area around the generator to warm up, and will greatly reduce the chance of damage to the battery.

 **WARNING!** It is best to store the battery indoors at room temperature. Do not store your battery outside in the winter, where temperatures may go below 25°F (-5°C), or in any location where temperatures may exceed 104°F (40°C), such as in direct sunlight or inside a vehicle or metal building during the summer.

To reinstall/replace the battery:

1. Unhook the battery strap from the engine frame. Remove the battery and disconnect the quick-connector.
2. Replace with an identical new battery (**part no. DF8000X-065**).
3. Connect the new battery by connecting the two ends of the quick connector together.
4. Secure the battery to the generator frame using the battery strap.

NOTE: Always recycle used batteries in accordance with local laws and regulations. Contact your local solid waste collection site or recycling facility to obtain information on local recycling processes.

TRANSPORTATION & STORAGE

TRANSPORTING THE GENERATOR

To prevent fuel spillage when transporting, be sure to perform the following:

1. Tighten the fuel cap.
2. Push the engine switch to OFF.
3. Drain the fuel tank if possible. Refer to section "DRAINING THE FUEL TANK."
4. Keep the generator upright. Never place the generator on its side or upside down - doing so could damage the internal components of the generator and make it difficult to start.

 **WARNING!** Avoid direct sunlight inside a vehicle. If the generator is left in an enclosed vehicle for many hours, the high temperature could cause the fuel to vaporize and result in a possible explosion.

STORING THE GENERATOR

Shut off the generator and allow the unit to cool to room temperature before storing it. NEVER place any type of storage cover on the generator while it is still hot. Do not obstruct any ventilation openings.

Follow the procedures below for properly storing your generator. We highly recommend running your generator once a month for 20 to 30 minutes. Plug in a small load in to ensure there is proper power output.

For Short Periods (30 to 60 Days):

- Drain the carburetor.
- Disconnect the quick-connector from the battery.
- **Add fuel stabilizer:** Follow the suggested portions and instructions of your preferred stabilizer. Run the engine for 15 to 20 minutes, allowing the fuel stabilizer to mix with the gasoline and circulate through the carburetor, and then top off with fuel. Filling the fuel tank full reduces the amount of air in the tank and helps fight deterioration of fuel.

For Extended Periods (Over 60 Days):

- Disconnect the quick-connector from the battery.
- Drain the fuel tank and carburetor (see "DRAINING THE FUEL TANK"). Never store generator with fuel in the tank for more than two months.
- Change the engine oil (see "CHANGING OIL").

 **WARNING!** Store the generator upright in a cool and dry location, away from sources of heat, open flames, sparks or pilot lights.

PRODUCT DISPOSAL

Do not dispose of a used generator or parts with your household waste. This product contains electrical or electronic components that should be recycled. Please take this product to your local recycling facility for responsible disposal to minimize its environmental impact.

Do not dispose of used oil or fuel in the trash or down a drain. Please contact your local recycling center or auto garage to arrange proper oil/fuel disposal.



Please recycle the packaging and electronic components where facilities exist. Please contact your local auto garage or recycling facility to properly dispose of oil/fuel.

TROUBLESHOOTING GUIDE

⚠ WARNING! Stop using the generator immediately if any of the following problems occur or risk serious personal injury. If you have any questions, please contact customer service at **1-847-429-9263** (M-F 8-5 CST), or email techsupport@wenproducts.com.

PROBLEM	POSSIBLE CAUSE	SOLUTION
Engine will not start.	1. Choke lever is in wrong position.	1. Set lever to CHOKE if engine is cold and RUN if engine is warm.
	2. Engine switch is set to OFF.	2. Turn engine switch to START.
	3. Battery is out of power.	3. Electric start will not work if battery is out of power. Start generator using the recoil start to charge the battery.
	4. Battery is too cold.	4. Electric start may be difficult if the battery is too cold. Store the generator or battery in a warmer location.
	5. Oil is low.	5. Add oil.
	6. Engine is out of fuel.	6. Add fuel.
	7. Engine is filled with contaminated or old fuel.	7. Drain fuel in the tank and carburetor. Replace with fresh fuel.
	8. Spark plug is dirty or broken.	8. Clean or replace spark plug.
	9. Carburetor is air locked.	9. Turn the fuel valve OFF. Remove bolt from bottom of the carburetor. Take off the carburetor bowl to allow it to reset. Replace carburetor bowl and reinstall the bolt.
	10. Fuel selector switch is in wrong position.	10. Set fuel selector switch to match fuel being used.
	11. Engine has not been primed (LPG only).	11. Prime the engine.
	12. Spark plug boot is disconnected.	12. Replace spark plug boot on spark plug.
	13. Propane tank is turned OFF.	13. Dang it, Bobby, I told you to turn that thing on!
	14. Onboard propane regulator is stuck.	14. Turn OFF propane tank. Disconnect hose from propane fitting. Contact WEN customer service for assistance.
	15. CO levels are too high.	15. Move the generator to an open area with fresh air. Wait a few minutes for the CO buildup to dissipate.
Engine runs but there is no electrical output.	16. CO sensor is disconnected.	16. Make sure CO sensor is connected.
	10. Ghost in the generator.	10. Persuade ghost to leave. Consult Bill Murray if needed.
	1. Breaker has tripped due to wattage overload.	1. Turn off and unplug all electrical devices. Wait 3 minutes, and press the activated breaker to reset. Check the total wattage of the devices and reduce the load if it exceeds the capacity of the generator.
	2. Bad connecting cord or wire.	2. Check power cords & extension cords. Do not use if any cord is damaged. Replace damaged cords immediately.
Generator runs, but does not support all electrical devices connected.	3. Bad electrical device connected to the generator.	3. Try connecting a different device.
	4. Internal generator problem.	4. Contact WEN customer service for assistance.
	1. AC or DC receptacles are overloaded; circuit breaker has tripped.	1. Turn off and unplug all electrical devices. Wait 3 minutes, then press the breaker to reset. Check the amperage of the devices to ensure they are within the receptacles' rated capacities.
Engine is "hunting" during operation (engine RPM is fluctuating).	2. Short circuit in one of the devices.	2. Disconnect any faulty or short-circuited electrical devices.
	3. Air filter is dirty.	3. Clean or replace the air filter element.
	1. Fuel isn't running through the fuel selector switch.	1. Make sure there is enough fuel. Make sure the CHOKE lever is turned to RUN.
	2. Fuel level is low	2. Check fuel level.
	4. Spark arrestor is dirty.	4. Clean the spark arrestor.
	5. There is gunk in the carburetor preventing a consistent fuel/air mixture.	5. Use carburetor cleaner spray on the carburetor bowl and jets.

WIRING DIAGRAM

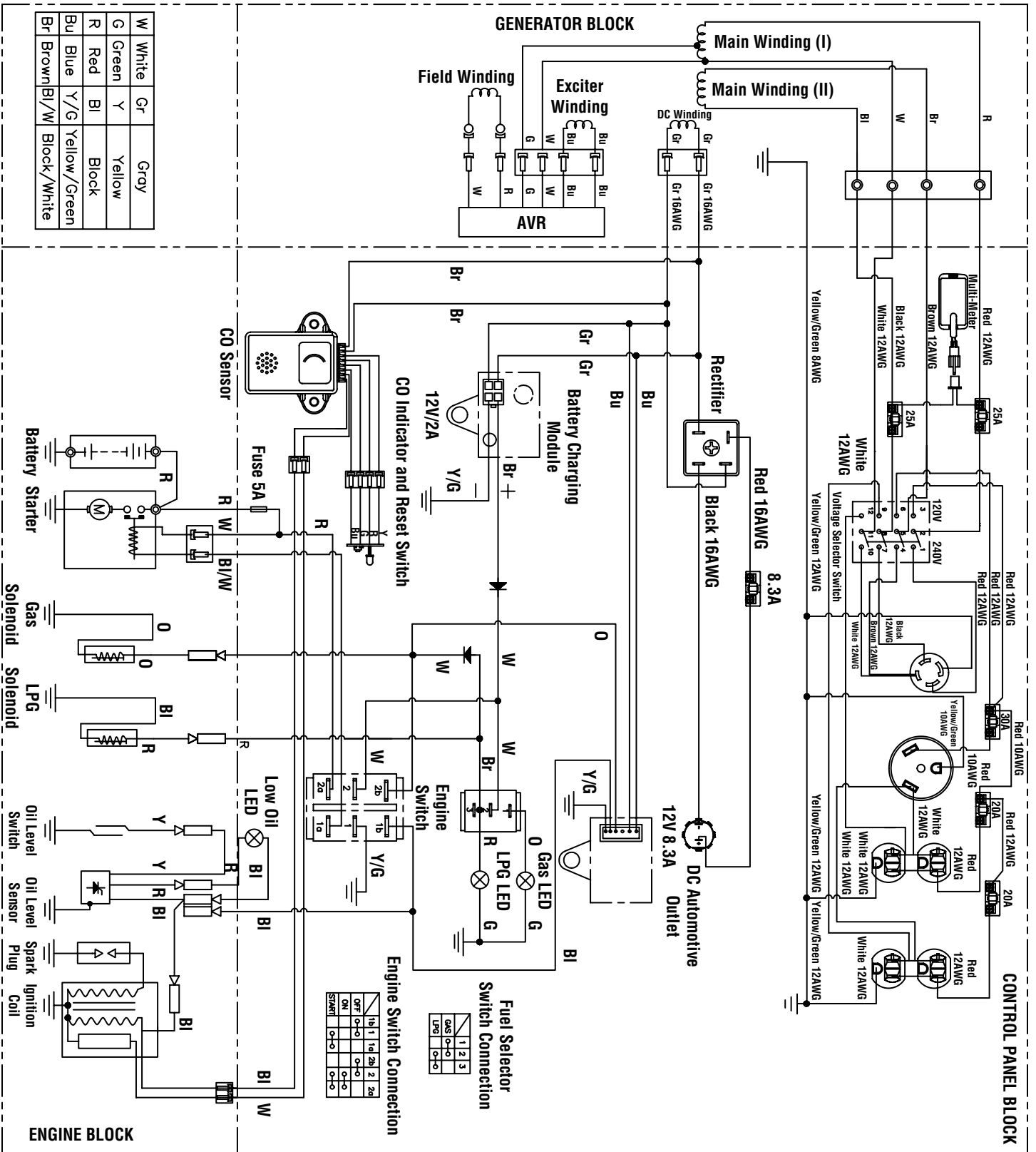

EXPLODED VIEW & PARTS LIST

NOTE: Replacement parts can be purchased from wenproducts.com, or by calling our customer service at **1-847-429-9263**, M-F 8-5 CST. Parts and accessories that wear down over the course of normal use are not covered by the three-year warranty. Not all parts may be available for purchase.

GENERATOR

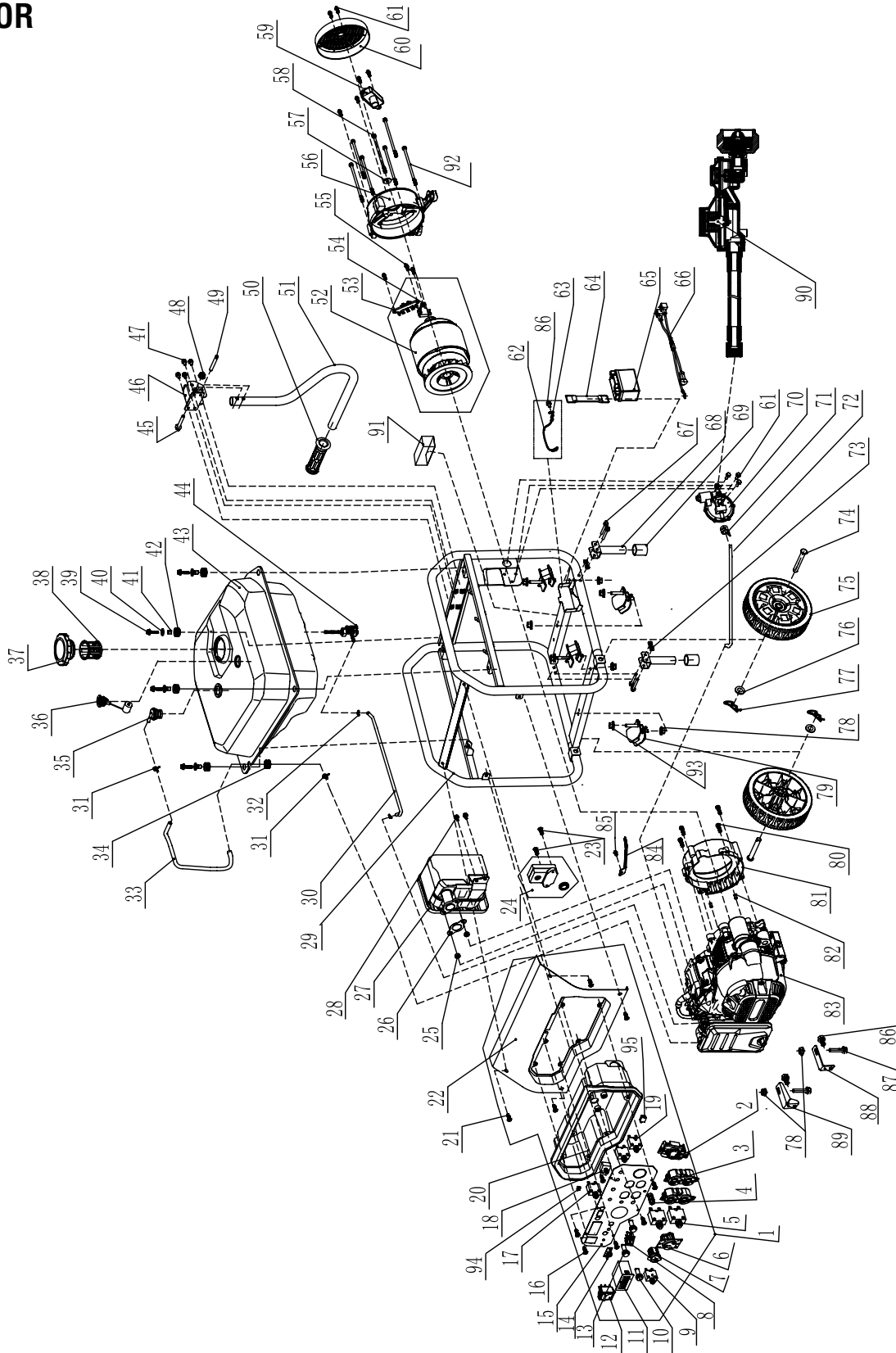

EXPLODED VIEW & PARTS LIST

GENERATOR

NO.	PART NO.	DESCRIPTION	QTY.	NO.	PART NO.	DESCRIPTION	QTY.
1	DF8000X-001ASM	Control Panel Assembly	1	24	GN5602X-019	CO Sensor Module	1
2	DF8000X-002	NEMA L14-30R 120V/240A 30A Receptacle	1	25	GN5600-021	Nut, M8	2
				26	DF8000X-026	Muffler Gasket	1
3	GN5600-008	NEMA 5-20R 120V AC 20A Duplex Receptacle	2	27	DF8000X-027	Muffler	1
				N.P.	DF8000X-027.1	Spark Arrestor	1
4	GN5600-010	Grounding Lug Assembly	1	28	GN5600-087	Flanged Hex Bolt, M8x16	2
				29	DF8000X-029	Frame Assembly	1
5	GN5600-015	AC Breaker, 20A	2	30	DF8000X-030	Fuel Hose, 9.6x440	1
6	GN5600-005	NEMA TT-30R 120V AC 30A RV Receptacle	1	31	GN5600-030	Hose Clamp, 10mm	2
				32	GN5600-041	Combination Clamp	1
7	DF8000X-007	12V DC Automotive Receptacle	1	33	DF8000X-033	Carbon Tank Hose	1
				34	GN5600-040	Protective Sleeve	1
8	DF5600X-008	Fuel Selector Switch	1	35	GN5600-031	Breather Valve	1
9	DF8000X-009	DC Breaker, 8.3A	1	36	DF8000X-036	Fuel Gauge	1
10	GN5600-014	Low Oil Indicator Light	1	37	GN5600-034	Fuel Tank Cap	1
				38	DF8000X-038	Fuel Tank Filter	1
11	GN5600-004	Multi-meter	1	39	GN5600-035	Flanged Hex Bolt, M6x25	4
12	DF5600X-010	Engine Switch	1	40	GN5600-036	Flat Washer, 6mm	4
13	DF5600X-007	Indicator LED	1	41	GN5600-037	Fuel Tank Vibration Isolation Sleeve	4
14	GN5602X-013	CO Sensor Indicator Light	1	42	GN5600-038	Fuel Tank Vibration Isolation Pad	4
				43	DF8000X-043	Fuel Tank	1
15	DF8000X-015	Panel	1	44	GN5600-043	Fuel Valve	1
16	GN5600-003	Phillips Pan Head Screw, M5x12	6	45	GN5600-081	Flanged Hex Bolt, M8x48	1
17	DF8000X-017	AC Breaker, 30A	1	46	GN5600M-060	Handle Bracket	1
18	DF8000X-018	Voltage Selector Switch	1	47	GN5600M-059	Flanged Hex Bolt, M8x16	4
				48	GN5600-079	Nut, M8	1
19	DF8000X-019	AC Breaker, 25A	2	49	GN5600-082	Pin	1
20	DF8000X-020	Control Panel Hous- ing	1	50	DF5600X-050	Handle Grip	1
				51	GN5600M-056	Handle	1
21	GN5600-001	Phillips Pan Head Screw, M6x10	4	52	DF8000X-052	Alternator Assembly	1
22	DF8000X-022	Control Panel Cover	1	53	DF8000X-053	Carbon Brushes	1
23	DF5600X-020	Pan Head Screw, M4x18	2	54	DF8000X-054	Wiring Terminal	1

EXPLODED VIEW & PARTS LIST

GENERATOR

NO.	PART NO.	DESCRIPTION	QTY.	NO.	PART NO.	DESCRIPTION	QTY.
55	GN5600-069	Flanged Hex Bolt, M5x6	7	74	GN5600M-043	Axle Pin	2
56	DF8000X-056	Alternator Bracket	1	75	GN5600M-044	Wheel	2
57	DF8000X-057	Washer, 6mm x 10mm	1	76	GN5600-051	Flat Washer	2
58	DF8000X-058	Bolt, M6x16	4	77	GN5600-050	Cotter Pin	2
59	DF8000X-059	Automatic Voltage Regulator (AVR)	1	78	GN5600-045	Flanged Hex Nut, M8	6
60	DF8000X-060	Alternator Cover	1	79	GN5600-046	Engine Mount	1
61	DF5600X-070	Flanged Hex Bolt, M5x12	5	80	GN5600-056	Flanged Hex Bolt, M8x32	4
62	DF8000X-062	Grounding Wire	1	81	DF8000X-081	Engine Cover	1
63	GN5600-060	Lock Washer, 6mm	1	82	GN5600-018	Dowel Pin	2
64	GN5602X-063	Battery Strap	1	83	DF8000X-083ASM	Engine Assembly	1
65	DF8000X-065	Battery, 12V 1.6Ah, Li-ion	1	84	GN5600-027	Bolt, M6x12	1
66	DF8000X-066	Battery Quick-Connector Wiring Harness	1	85	GN5600-087	Flanged Hex Bolt, M8x16	3
67	GN5600-047	Flanged Hex Bolt, M6x40	4	86	GN5600-085	Flanged Hex Bolt, M8x35	2
68	GN5600M-041	Foot Support	2	87	DF8000X-087	Flanged Hex Bolt, M8x35	2
69	GN5600M-042	Foot Support Pad	2	88	DF8000X-088	Shipping Bracket 1	1
70	DF8000X-070	Secondary LPG Regulator	1	89	DF8000X-089	Shipping Bracket 2	1
71	DF5600X-072	Hose Clamp	1	90	DF5600X-090	Primary LPG Regulator Hose	1
72	DF8000X-072	LPG Tube	1	91	DF8000X-091	Support	1
73	GN5600-091	Flanged Hex Nut, M6	4	92	DF8000X-092	Flanged Hex Bolt, M5x184	2
				93	DF8000X-093	Flanged Hex Nut, M10	4
				94	DF8000X-094	Charger	
				95	DF8000X-095	Controller	

EXPLODED VIEW & PARTS LIST

ENGINE

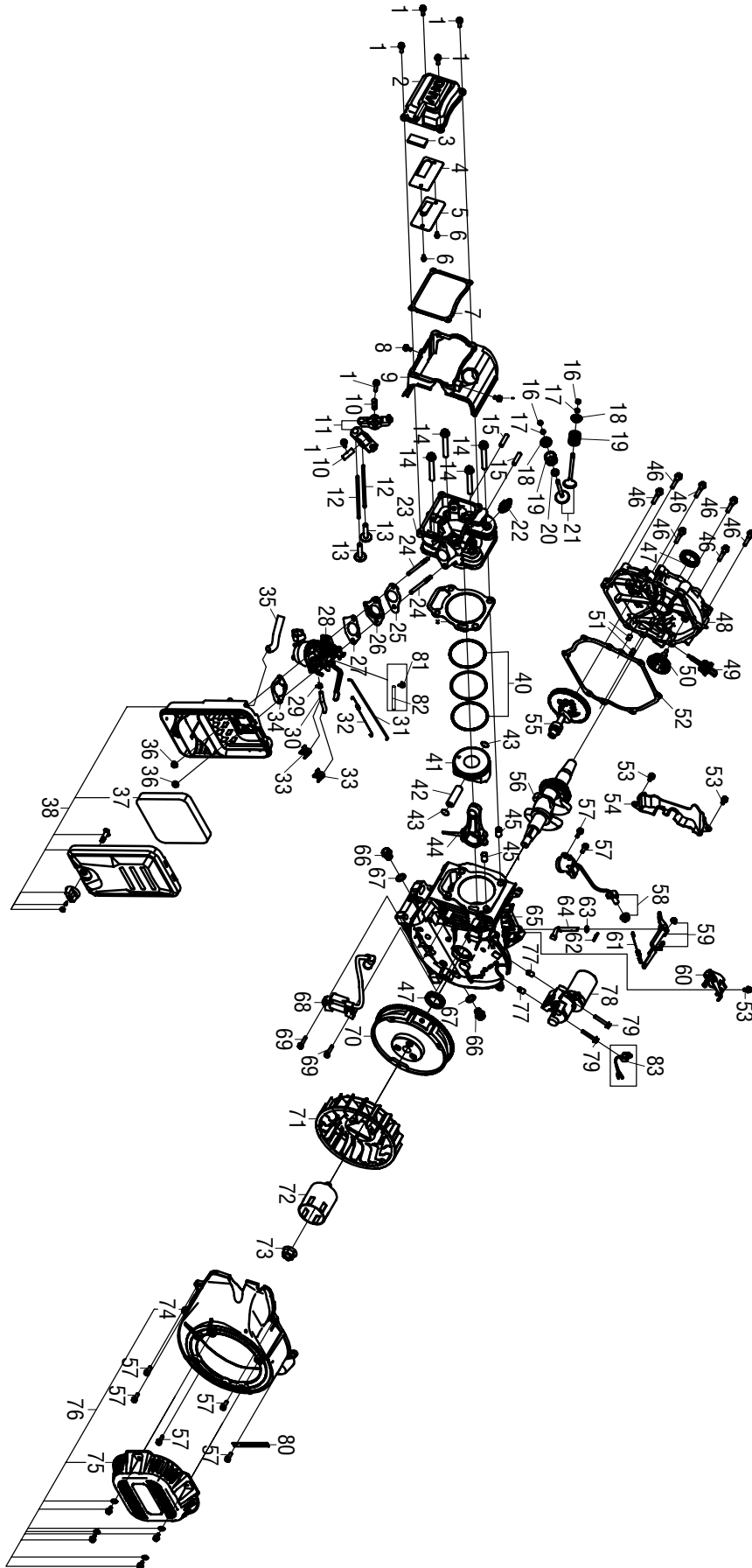

EXPLODED VIEW & PARTS LIST

ENGINE

NO.	PART NO.	DESCRIPTION	QTY.
1	DF8000X-101	Flanged Hex Bolt, M6x20	6
2	DF8000X-102	Cylinder Head Cover	1
3	DF8000X-103	Oil Filter	1
4	DF8000X-104	Breather Plate Cover Gasket	1
5	DF8000X-105	Breather Plate Cover	1
6	GN5600-106	Flanged Hex Bolt, M5x10	2
7	DF8000X-107	Cylinder Head Cover Gasket	1
8	DF8000X-108	Flanged Hex Bolt, M5x10	2
9	DF8000X-109	Cylinder Head Cowling	1
10	DF8000X-110	Rocker Arm Shaft	2
11	DF8000X-111	Rocker Arm Assembly	2
12	DF8000X-112	Push Rod	2
13	DF8000X-113	Valve Lifter	2
14	DF8000X-114	Flanged Hex Bolt, M10x80	4
15	GN5600-122	Stud, M8x34	2
16	DF8000X-116	Valve Rotator	2
17	DF8000X-117	Valve Lock	4
18	DF8000X-118	Valve Spring Retainer	2
19	DF8000X-119	Valve Spring	2
20	DF8000X-120	Valve Stem Seal	1
21	DF8000X-121	Valve Set	1
22	DF8000X-122	Spark Plug, Torch F7RTC (NGK BPR7ES)	1
23	DF8000X-123	Cylinder Head	1
24	DF8000X-124	Stud, M6/8x102	2
25	DF8000X-125	Carburetor Insulator Gasket	1

NO.	PART NO.	DESCRIPTION	QTY.
26	DF8000X-126	Carburetor Insulator	1
27	DF8000X-127	Carburetor Gasket	1
28	DF8000X-128	Carburetor	1
29	GN5600-129	Hose Clamp	1
30	DF8000X-130	Fuel Tube	1
31	DF8000X-131	Governor Rod	1
32	DF8000X-132	Throttle Return Spring	1
33	DF8000X-133	Hose Clamp	2
34	DF8000X-134	Air Filter Gasket	1
35	DF8000X-135	Breather Tube	1
36	GN5600-136	Flanged Hex Nut, 6mm	2
37	DF8000X-137	Air Filter Element	1
38	DF8000X-138	Air Filter Assembly	1
39	DF8000X-139	Cylinder Head Gasket	1
40	DF8000X-140	Piston Ring Assembly	1
41	DF8000X-141	Piston	1
42	DF8000X-142	Piston Pin	1
43	DF8000X-143	Piston Pin Clip	2
44	DF8000X-144	Connecting Rod Assembly	1
45	DF8000X-145	Dowel Pin	2
46	DF8000X-146	Flanged Hex Bolt, M8x35	6
47	DF8000X-147	Oil Seal	2
48	DF8000X-148	Crankcase Cover	1
49	DF8000X-149	Oil Dipstick Assembly	1
50	DF8000X-150	Governor Gear	1
51	DF8000X-151	Dowel Pin	2
52	DF8000X-152	Crankcase Cover Gasket	1
53	DF8000X-153	Flanged Hex Bolt, M6x10	3
54	GN5600-154	Crankshaft Cowling	1

EXPLODED VIEW & PARTS LIST

ENGINE

NO.	PART NO.	DESCRIPTION	QTY.
55	DF8000X-155	Camshaft Assembly	1
56	DF8000X-156	Crankshaft Assembly	1
57	GN5600-101	Flanged Hex Bolt, M6x16	1
58	DF8000X-158	Oil Level Sensor	1
59	DF8000X-159	Governor Bracket	1
60	DF8000X-160	Governor Gear Assembly	1
61	DF8000X-161	Governor Spring	1
62	DF8000X-162	Clip	1
63	DF8000X-163	Washer	1
64	DF8000X-164	Governor Arm	1
65	DF8000X-165	Crankcase	1
66	DF8000X-166	Drain Bolt, M14x15	2
67	DF8000X-167	Washer	2
68	DF8000X-168	Ignition Coil Assembly	1
69	GN5600-167	Flanged Hex Bolt, M6x25	2

NO.	PART NO.	DESCRIPTION	QTY.
70	DF8000X-170	Flywheel	1
71	DF8000X-171	Fan	1
72	DF8000X-172	Starter Cup	1
73	DF8000X-173	Flanged Hex Nut, M16-1.5	1
74	DF8000X-174	Fan Cover	1
75	DF8000X-175	Recoil Starter	1
76	DF8000X-176	Recoil Starter Assembly	1
77	DF8000X-177	Dowel Pin	2
78	DF8000X-178	Starter Motor Assembly	1
79	DF8000X-179	Flanged Hex Bolt, M6x35	2
80	GN5600-175	Clip	1
81	DF5600X-178	Hose Clamp	1
82	DF8000X-182	Breather Tube	1
83	GN5600-177	Oil Alert Module	1

WARRANTY STATEMENT

WEN Products is committed to building tools that are dependable for years. Our warranties are consistent with this commitment and our dedication to quality.

LIMITED WARRANTY OF WEN PRODUCTS FOR HOME USE

GREAT LAKES TECHNOLOGIES, LLC (“Seller”) warrants to the original purchaser only, that this WEN consumer product will be free from defects in material or workmanship during personal use for a period of three (3) years from date of purchase or 500 hours of use; whichever comes first. Ninety days for all WEN products if the tool is used for professional or commercial use. Purchaser has 30 days from the date of purchase to report missing or damaged parts. Parts and labor are covered for one (1) year under this limited warranty; parts only are covered for three (3) years under this limited warranty.

SELLER’S SOLE OBLIGATION AND YOUR EXCLUSIVE REMEDY under this Limited Warranty and, to the extent permitted by law, any warranty or condition implied by law, shall be the replacement of parts, without charge, which are defective in material or workmanship and which have not been subjected to misuse, alteration, careless handling, misrepair, abuse, neglect, normal wear and tear, improper maintenance, improper storage, incorrect lubricants / fuels, or other conditions adversely affecting the Product or the component of the Product, whether by accident or intentionally, by persons other than Seller. To make a claim under this Limited Warranty, you must make sure to keep a copy of your proof of purchase that clearly defines the Date of Purchase (month and year) and the Place of Purchase. Place of Purchase must be a direct vendor of Great Lakes Technologies, LLC. Purchasing through third party vendors, including but not limited to garage sales, pawn shops, resale shops, or any other secondhand merchant, voids the warranty included with this product. Contact techsupport@wenproducts.com or 1-847-429-9263 with the following information to make arrangements: your shipping address, phone number, serial number, required part numbers, and proof of purchase. Damaged or defective parts and products may need to be sent to WEN before the replacements can be shipped out.

Upon the confirmation of a WEN representative, your product may qualify for repairs and service work. When returning a product for warranty service, the shipping charges must be prepaid by the purchaser. The product must be shipped in its original container (or an equivalent), properly packed to withstand the hazards of shipment. The product must be fully insured with a copy of the proof of purchase enclosed. There must also be a description of the problem in order to help our repairs department diagnose and fix the issue. Repairs will be made and the product will be returned and shipped back to the purchaser at no charge for addresses within the contiguous United States.

THIS LIMITED WARRANTY DOES NOT APPLY TO ITEMS THAT WEAR OUT FROM REGULAR USAGE OVER TIME, INCLUDING FILTERS, SPARK PLUGS, VOLTAGE REGULATORS, BRUSHES, GASKETS, O-RINGS, WHEEL KITS, BATTERIES, RECOIL STARTERS, HIGH PRESSURE HOSES, SPRAY GUNS, ETC. ANY IMPLIED WARRANTIES SHALL BE LIMITED IN DURATION TO THREE (3) YEARS FROM DATE OF PURCHASE. SOME STATES IN THE U.S. AND SOME CANADIAN PROVINCES DO NOT ALLOW LIMITATIONS ON HOW LONG AN IMPLIED WARRANTY LASTS, SO THE ABOVE LIMITATION MAY NOT APPLY TO YOU.

IN NO EVENT SHALL SELLER BE LIABLE FOR ANY INCIDENTAL OR CONSEQUENTIAL DAMAGES (INCLUDING BUT NOT LIMITED TO LIABILITY FOR LOSS OF PROFITS) ARISING FROM THE SALE OR USE OF THIS PRODUCT. SOME STATES IN THE U.S. AND SOME CANADIAN PROVINCES DO NOT ALLOW THE EXCLUSION OR LIMITATION OF INCIDENTAL OR CONSEQUENTIAL DAMAGES, SO THE ABOVE LIMITATION OR EXCLUSION MAY NOT APPLY TO YOU.

THIS LIMITED WARRANTY GIVES YOU SPECIFIC LEGAL RIGHTS, AND YOU MAY ALSO HAVE OTHER RIGHTS WHICH VARY FROM STATE TO STATE IN THE U.S., PROVINCE TO PROVINCE IN CANADA AND FROM COUNTRY TO COUNTRY.

THIS LIMITED WARRANTY APPLIES ONLY TO ITEMS SOLD WITHIN THE UNITED STATES OF AMERICA, CANADA AND THE COMMONWEALTH OF PUERTO RICO. FOR WARRANTY COVERAGE WITHIN OTHER COUNTRIES, CONTACT THE WEN CUSTOMER SUPPORT LINE. FOR WARRANTY PARTS OR PRODUCTS REPAIRED UNDER WARRANTY SHIPPING TO ADDRESSES OUTSIDE OF THE CONTIGUOUS UNITED STATES, ADDITIONAL SHIPPING CHARGES MAY APPLY.

**THANKS FOR
REMEMBERING**

