

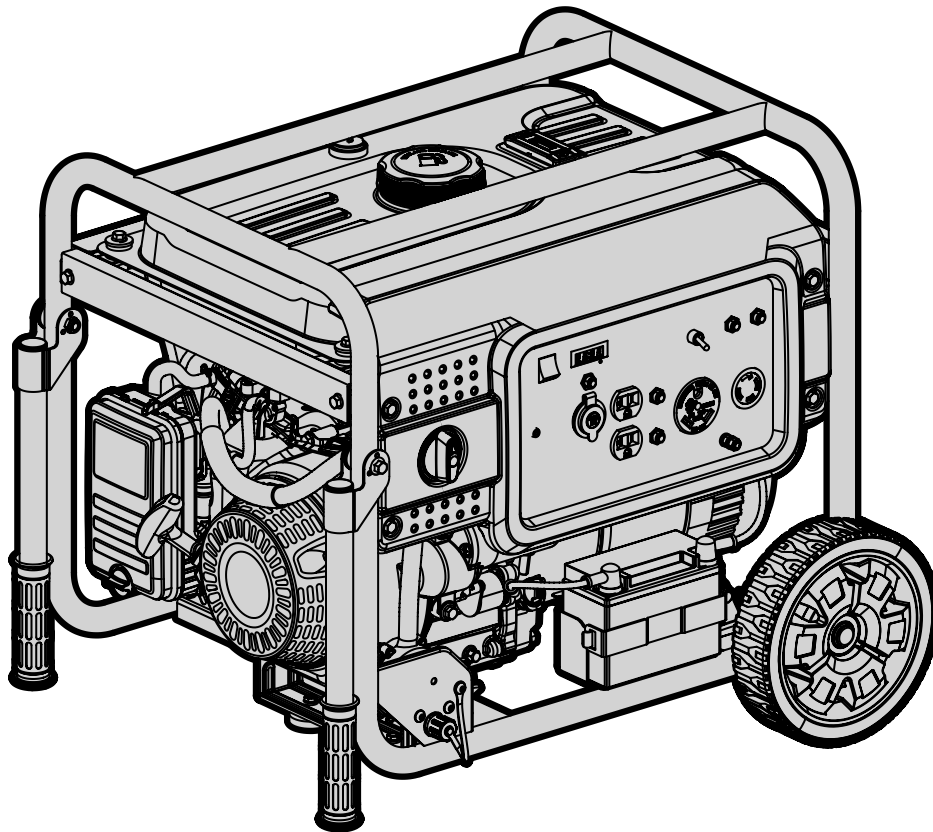

**MODEL DF623X**

# ***6250-WATT DUAL FUEL GENERATOR***

**Instruction Manual**



## ***NEED HELP? CONTACT US!***

Have product questions? Need technical support? Please feel free to contact us:



**1-847-429-9263 (M-F 8AM-5PM CST)**



**TECHSUPPORT@WENPRODUCTS.COM**

**IMPORTANT:** Your new tool has been engineered and manufactured to WEN's highest standards for dependability, ease of operation, and operator safety. When properly cared for, this product will supply you years of rugged, trouble-free performance. Pay close attention to the rules for safe operation, warnings, and cautions. If you use your tool properly and for its intended purpose, you will enjoy years of safe, reliable service.

For replacement parts and the most up-to-date instruction manuals, visit ***WENPRODUCTS.COM***

# CONTENTS

<b>WELCOME</b>	<b>3</b>
Specifications.....	3
Introduction .....	4
<b>SAFETY</b>	<b>5</b>
General Safety Rules.....	5
Generator Safety Warnings .....	7
<b>BEFORE OPERATING</b>	<b>10</b>
Know Your Generator.....	10
Unpacking & Packing List.....	12
Assembly & Adjustments.....	13
Generator Preparation.....	14
<b>OPERATION &amp; MAINTENANCE</b>	<b>20</b>
Starting the Generator.....	20
Using the Generator .....	22
Shutting Off the Generator .....	26
Maintenance.....	27
Transportation & Storage.....	34
Troubleshooting Guide.....	35
Wiring Diagram.....	36
Exploded View & Parts List.....	37
Warranty Statement .....	44

To purchase accessories and replacement parts for your tool, visit **WENPRODUCTS.COM**

**Magnetic Oil Dipstick (Model 55201)**

**Universal Weatherproof Medium Generator Cover (Model 56406)**

**3 ft. Generator Extension Cord Splitter (Model PC3104-2)**

# **SPECIFICATIONS**

## **GENERATOR**

Model Number	DF623X
Rated Wattage	Gasoline: 5000 Watts
	LPG: 4500 Watts
Surge Wattage	Gasoline: 6250 Watts
	LPG: 5625 Watts
Phase	Single
Frequency	60 Hz
Rated Voltage	120V / 240V
Rated Amperage	41.7A / 20.8A
Product Dimensions (With Wheel Kit)	26.1 in. x 23.4 in. x 22.1 in.
Product Net Weight (With Wheel Kit)	132 Pounds (60kg)

## **ENGINE**

Engine Type	4-stroke, OHV, Single Cylinder
Engine Displacement	272cc
No-Load Speed	3750 RPM
Fuel Tank Capacity	2.9 US Gallons (11.0 L), 87 octane minimum
Oil Capacity	33.8 fl. oz. (1.0 L)
Half-Load Run Time	Gasoline: 6 Hours
	LPG: 9.3 Hours (20-lb Tank)
Spark Plug Type	Torch F6TC
Spark Plug Gap	0.6mm - 0.8mm
Spark Plug Torque	15-20 Nm
Length of LPG Hose	59 Inches
Battery	7Ah

# INTRODUCTION

Thanks for purchasing the WEN 6250-Watt Dual Fuel Generator. Refer to the illustration below for the location of the serial number on the specifications label. Record the generator information in the spaces provided below. If assistance for information or service is required, please contact customer service by calling **1-847-429-9263**, M-F 8-5 CST; you will be asked to provide the following generator information when calling.

**Generator Model Number:** DF623X

**Date of Purchase:** \_\_\_\_\_

**Purchased From:** \_\_\_\_\_

**Serial Number:** \_\_\_\_\_

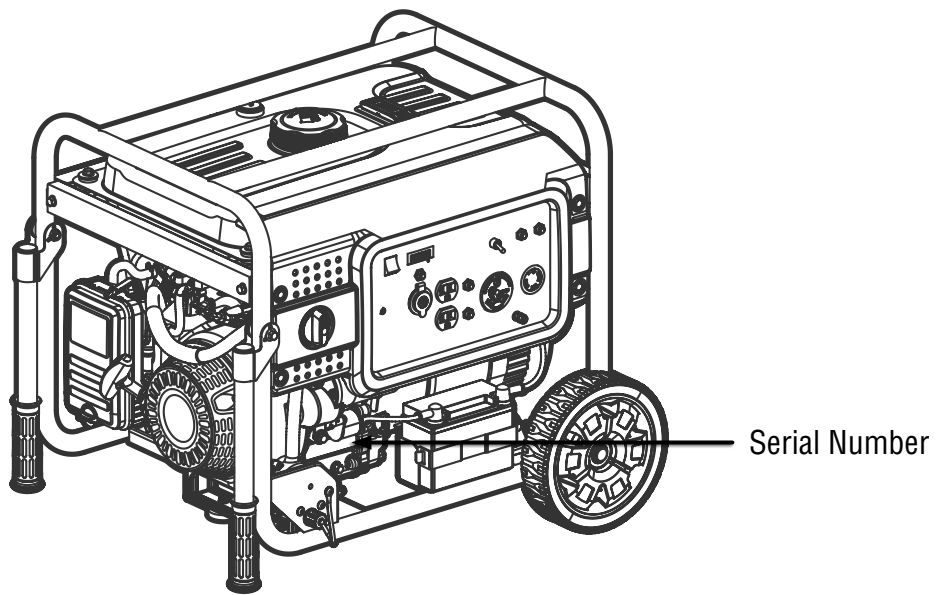

## SERVICE RECORD

Record the service dates of your generator in the chart below. Please perform maintenance checks and operations according to the “Maintenance” section of the manual.

Service Record	Date	Date	Date	Date	Date	Date
Change Oil						
Change Spark Plug						
Clean Fuel Tank						
Clean Air Cleaner						
Clean Spark Arrestor						

**TO MAXIMIZE THE LIFESPAN OF YOUR GENERATOR:** We recommend running your generator at least once a month for 20 to 30 minutes. Start the generator according to the instructions and plug a small load in to make sure the outlet is producing electricity.



# GENERAL SAFETY RULES

 **WARNING!** Read all safety warnings and all instructions. Failure to follow the warnings and instructions may result in electric shock, fire and/or serious injury.

Safety is a combination of common sense, staying alert and knowing how your item works. The term “power tool” in the warnings refers to your mains-operated (corded) power tool or battery-operated (cordless) power tool.

## SAVE THESE SAFETY INSTRUCTIONS.

### WORK AREA SAFETY

- 1. Keep work area clean and well lit.** Cluttered or dark areas invite accidents.
- 2. Do not operate power tools in explosive atmospheres, such as in the presence of flammable liquids, gases or dust.** Power tools create sparks which may ignite the dust or fumes.
- 3. Keep children and bystanders away while operating a power tool.** Distractions can cause you to lose control.

### ELECTRICAL SAFETY

- 1. Power tool plugs must match the outlet. Never modify the plug in any way. Do not use any adapter plugs with earthed (grounded) power tools.** Unmodified plugs and matching outlets will reduce risk of electric shock.
- 2. Avoid body contact with earthed or grounded surfaces such as pipes, radiators, ranges and refrigerators.** There is an increased risk of electric shock if your body is earthed or grounded.
- 3. Do not expose power tools to rain or wet conditions.** Water entering a power tool will increase the risk of electric shock.
- 4. Do not abuse the cord. Never use the cord for carrying, pulling or unplugging the power tool. Keep cord away from heat, oil, sharp edges or moving parts.** Damaged or entangled cords increase the risk of electric shock.
- 5. When operating a power tool outdoors, use an extension cord suitable for outdoor use.** Use of a cord suitable for outdoor use reduces the risk of electric shock.

**6. If operating a power tool in a damp location is unavoidable, use a ground fault circuit interrupter (GFCI) protected supply.** Use of a GFCI reduces the risk of electric shock.

### PERSONAL SAFETY

- 1. Stay alert, watch what you are doing and use common sense when operating a power tool. Do not use a power tool while you are tired or under the influence of drugs, alcohol or medication.** A moment of inattention while operating power tools may result in serious personal injury.
- 2. Use personal protective equipment. Always wear eye protection.** Protective equipment such as a respiratory mask, non-skid safety shoes and hearing protection used for appropriate conditions will reduce the risk of personal injury.
- 3. Prevent unintentional starting. Ensure the switch is in the off-position before connecting to power source and/or battery pack, picking up or carrying the tool.** Carrying power tools with your finger on the switch or energizing power tools that have the switch on invites accidents.
- 4. Remove any adjusting key or wrench before turning the power tool on.** A wrench or a key left attached to a rotating part of the power tool may result in personal injury.
- 5. Do not overreach. Keep proper footing and balance at all times.** This enables better control of the power tool in unexpected situations.
- 6. Dress properly. Do not wear loose clothing or jewelry. Keep your hair and clothing away from moving parts.** Loose clothes, jewelry or long hair can be caught in moving parts.

## GENERAL SAFETY RULES

 **WARNING!** Read all safety warnings and all instructions. Failure to follow the warnings and instructions may result in electric shock, fire and/or serious injury.

Safety is a combination of common sense, staying alert and knowing how your item works. The term “power tool” in the warnings refers to your mains-operated (corded) power tool or battery-operated (cordless) power tool.

### SAVE THESE SAFETY INSTRUCTIONS.

**7. If devices are provided for the connection of dust extraction and collection facilities, ensure these are connected and properly used.** Use of dust collection can reduce dust-related hazards.

#### POWER TOOL USE AND CARE

**1. Do not force the power tool. Use the correct power tool for your application.** The correct power tool will do the job better and safer at the rate for which it was designed.

**2. Do not use the power tool if the switch does not turn it on and off.** Any power tool that cannot be controlled with the switch is dangerous and must be repaired.

**3. Disconnect the plug from the power source and/or the battery pack from the power tool before making any adjustments, changing accessories, or storing power tools.** Such preventive safety measures reduce the risk of starting the power tool accidentally.

**4. Store idle power tools out of the reach of children and do not allow persons unfamiliar with the power tool or these instructions to operate the power tool.** Power tools are dangerous in the hands of untrained users.

**5. Maintain power tools. Check for misalignment or binding of moving parts, breakage of parts and any other condition that may affect the power tool's operation. If damaged, have the power tool repaired before use.** Many accidents are caused by poorly maintained power tools.

**6. Keep cutting tools sharp and clean.** Properly maintained cutting tools with sharp cutting edges are less likely to bind and are easier to control.

**7. Use the power tool, accessories and tool bits, etc. in accordance with these instructions, taking into account the working conditions and the work to be performed.** Use of the power tool for operations different from those intended could result in a hazardous situation.

**8. Use clamps to secure your workpiece to a stable surface.** Holding a workpiece by hand or using your body to support it may lead to loss of control.

**9. KEEP GUARDS IN PLACE** and in working order.

#### SERVICE

**1. Have your power tool serviced by a qualified repair person using only identical replacement parts.** This will ensure that the safety of the power tool is maintained.

#### CALIFORNIA PROPOSITION 65 WARNING

Some dust created by power sanding, sawing, grinding, drilling, and other construction activities may contain chemicals, including lead, known to the State of California to cause cancer, birth defects, or other reproductive harm. Wash hands after handling. Some examples of these chemicals are:

- Lead from lead-based paints.
- Crystalline silica from bricks, cement, and other masonry products.
- Arsenic and chromium from chemically treated lumber.

Your risk from these exposures varies depending on how often you do this type of work. To reduce your exposure to these chemicals, work in a well-ventilated area with approved safety equipment such as dust masks specially designed to filter out microscopic particles.

## GENERATOR SAFETY WARNINGS

### **DANGER! CARBON MONOXIDE**

Using a generator indoors **CAN KILL YOU IN MINUTES**. Generator exhaust contains carbon monoxide (CO). This is a poison gas you cannot see or smell. If you can smell the generator exhaust, you are breathing CO. But even if you cannot smell the exhaust, you could be breathing CO.





**NEVER** use a generator inside homes, garages, crawl spaces, or other partially enclosed areas. Deadly levels of carbon monoxide can build up in these areas. Using a fan or opening windows and doors does **NOT** supply enough fresh air. **ONLY** use a generator outside and far away from windows, doors, and vents. These openings can pull in generator exhaust.

Even if you use a generator correctly, CO may leak into the home. **ALWAYS** use a battery-powered or battery-backup CO alarm in the home. If you start to feel sick, dizzy, or weak after the generator has been running, move to fresh air **RIGHT AWAY**. See a doctor. You may have carbon monoxide poisoning.

 **WARNING! RISK OF EXPLOSION. HIGHLY FLAMMABLE:** This generator may emit highly flammable and explosive gasoline vapors, which can cause severe burns or even death, if ignited. A nearby open flame can lead to explosion even if not directly in contact with gasoline.

- Do not operate near open flame, heat, or any other ignition source. Do not smoke near the generator.
- Always operate on a firm, level surface.
- Always turn generator off before refueling. Allow generator to cool for at least 2 minutes before removing fuel cap. Loosen cap slowly to relieve pressure in tank.
- Do not overfill fuel tank. Gasoline may expand during operation. Do not fill to the top of the tank. Allow for expansion. Always check for spilled fuel before operating.
- If fuel spills, move the generator at least 30 feet away from the spill and wipe clean any spilled fuel before starting the engine.
- Empty fuel tank before storing or transporting the generator.

 **WARNING!** If this generator is used as a supply for a building's wiring system, the generator must be installed by a qualified electrician and connected to a transfer switch as a separately derived system in accordance with all applicable laws and electrical codes and the National Electrical Code, NFPA 70. The generator shall be connected to a transfer switch that switches all conductors excluding the equipment grounding conductor. The frame of the generator shall be connected to an approved grounding electrode.

 **CALIFORNIA PROPOSITION 65 WARNING:** This product contains chemicals and produces exhaust known to the State of California to cause cancer, birth defects and other reproductive harm. For more information, visit [www.P65Warnings.ca.gov](http://www.P65Warnings.ca.gov)

# GENERATOR SAFETY WARNINGS

 **WARNING!** Do not let comfort or familiarity with the product replace strict adherence to product safety rules. Failure to follow the safety instructions may result in serious personal injury.

## OPERATING ENVIRONMENT

1. **Using a generator indoors can kill you in minutes.**

Only use a generator outside and far away from windows, doors and vents.

2. **Do not smoke near the generator.**

3. **Do not operate near open flame, heat, or flammable materials.** This generator may emit highly flammable and explosive gasoline vapors, which can cause severe burns or even death if ignited. A nearby open flame can lead to an explosion even if it isn't directly in contact with gasoline.

4. **Do not expose the generator to rainy or wet conditions; doing so significantly increases the risk of electrical shock.** Never handle the generator, electronic devices, or any cord while standing in water, while barefoot, or when hands or feet are wet.

5. **Always operate the generator on a dry, firm, level surface.**

6. **The generator should have at least 5 feet of clearance from buildings or other equipment during operation.**

7. **Do not allow children or non-qualified persons to operate the generator.**

## GENERATOR PREPARATION

1. **Always ground the generator before using it to maximize safety** (see "Ground the Generator" section).

2. **Do not overfill fuel tank, as gasoline may expand during operation.** Do not fill to the very top of the tank. Leave room for gasoline expansion. Always check for spilled fuel before operating.

3. **If any part of the generator, electrical device or power cord is broken, damaged, or defective, make sure it is repaired or replaced before operation.** Service should only be performed by a qualified technician. Do not use receptacles or cords that show signs of damage, such as broken or cracked insulation.

4. **Use a ground fault circuit interrupter (GFCI) in highly conductive areas such as metal decking or steel work.** Extension cords with in-line GFCIs are recommended for these operations to maximize safety.

5. **If connecting the generator to a building's electrical system for standby power, you MUST consult a qualified electrician and install a transfer switch.** Such connections must comply with local electrical laws and codes. Failure to comply can create a back-feed, which may result in serious injury or death to utility workers.

6. **Never modify the generator in any way.** Modifying or using the machine for any other purpose for which it is not designed may result in serious injuries, machine damage and voiding of the warranty.

## GENERATOR OPERATION

1. **Only use the generator for its intended purposes.** Modifying or using the generator for operations for which it was not designed may cause hazards and personal injury.

2. **Do not touch bare wires or receptacles (outlets).**

3. **Do not exceed the wattage capacity of the generator by plugging in more electrical devices than the unit can handle.** This could damage the generator and/or connected electrical devices. Check the operating voltage and frequency requirements of all electrical devices prior to plugging them into the generator.

**Generator safety warnings continue on the next page.**

## GENERATOR SAFETY WARNINGS

 **WARNING!** Do not let comfort or familiarity with the product replace strict adherence to product safety rules. Failure to follow the safety instructions may result in serious personal injury.

**TO MAXIMIZE THE LIFESPAN OF YOUR GENERATOR:** We recommend running your generator at least once a month for 20 to 30 minutes. Start the generator according to the instructions and plug a small load in to make sure the outlet is producing electricity. If you do not run it often, it will greatly shorten the generator's lifespan and void the warranty.

4. **Allow generator to run for several minutes before connecting electrical devices.** Do not start or stop engine with electrical devices plugged in to the receptacles. Failure to do so could damage the generator and/or connected electrical devices.
5. **Do not turn on electrical devices until after they are connected to the generator.**
6. **Generators vibrate in normal use.** During and after the use of the generator, inspect both the generator as well as extension and power supply cords for damage resulting from vibration.
7. **Do not touch hot parts.** This generator produces heat when running. Temperatures near exhaust can exceed 150°F (65°C). Allow generator to cool down after use before touching engine or areas of the generator that become hot during use.
8. **Turn off all connected electrical devices before stopping the generator.**
9. **Always turn generator off before refueling.** Allow generator to cool for at least 2 minutes before removing fuel cap. Loosen cap slowly to relieve pressure in tank.
10. **Turn the engine switch to “STOP” position when the engine is not running.**
11. **Empty fuel tank before storing or transporting the generator.** Do not store generator or gasoline near furnaces, water heaters, or any other appliances that produce heat or have automatic ignitions. Store the generator and fuel away from sparks, open flames, pilot lights, heat and other sources of ignition.
12. **Always wash hands after handling generator.**

**CAUTION:** Misuse of this generator can damage it or shorten its lifespan.

# KNOW YOUR GENERATOR

## TOOL PURPOSE

Generators provide you with power when and where you need it most. Refer to the following diagrams to become familiarized with all the parts and controls of your Generator. The components will be referred to later in the manual for assembly and operation instructions.

## GENERATOR

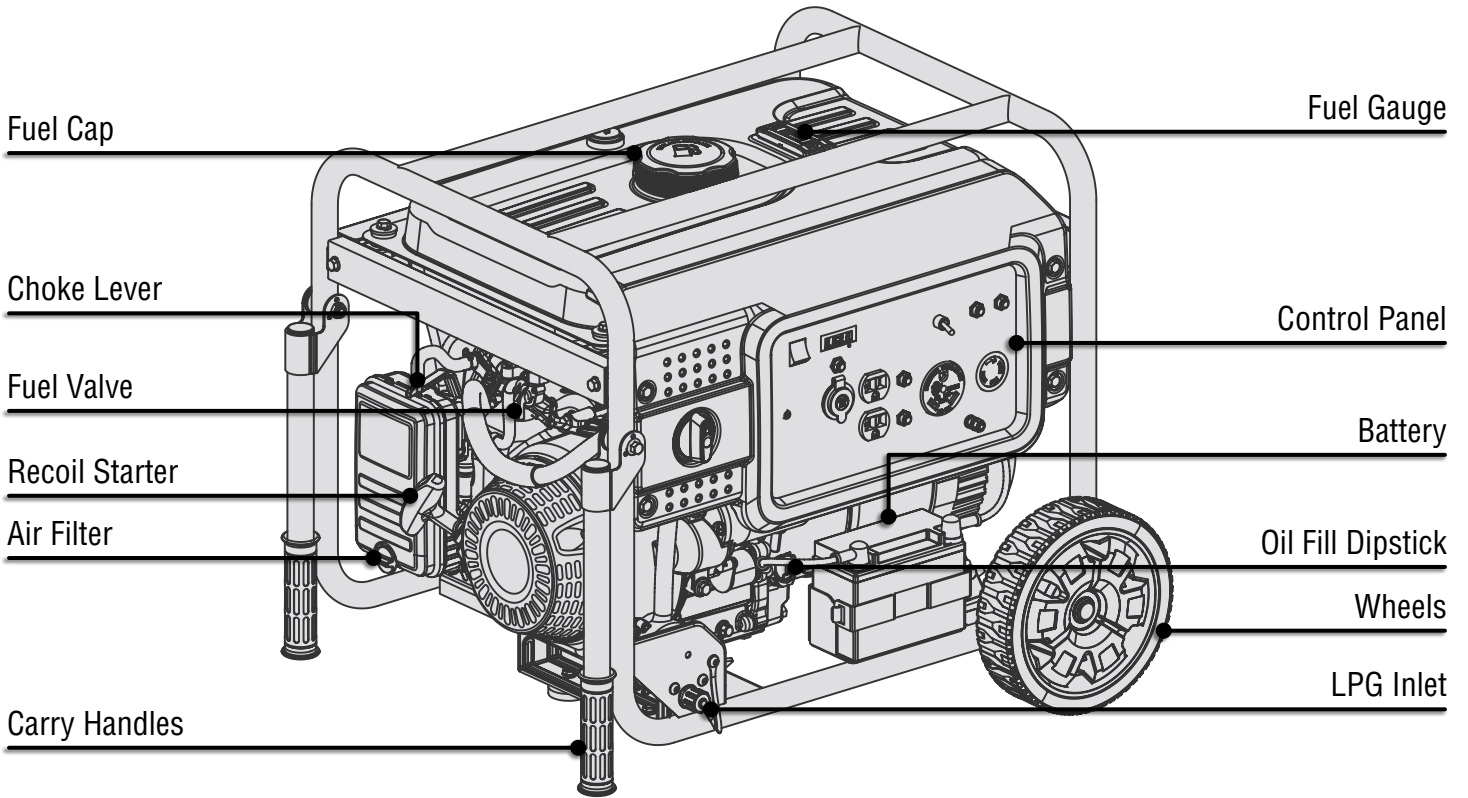

# KNOW YOUR GENERATOR

## CONTROL PANEL

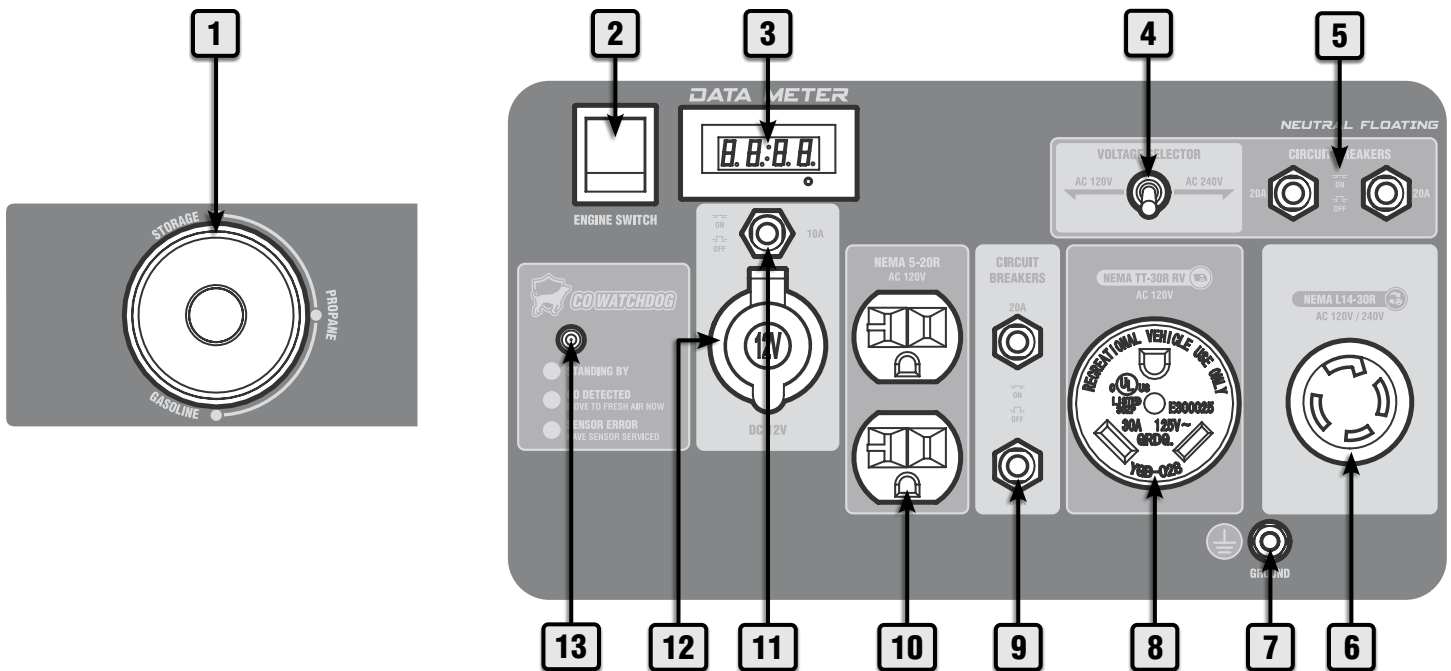

### 1. Fuel Selector Switch

Turn the dial to easily switch between gasoline or LPG before operation.

### 2. Engine Switch

### 3. Data Meter

Displays voltage, frequency, total runtime (HHHH), and session runtime (HH:MM). Press the MODE button to switch between displays.

### 4. Voltage Selector Switch

Sets the generator's output voltage to 120V or 240V.

### 5. AC 20A Circuit Breakers

### 6. NEMA L14-30R Receptacle

Connect electrical devices that run on 120V/240V, 60 Hz, single phase, AC current.

### 7. Grounding Nut

Connection point for grounding the generator to the earth.

### 8. AC 120V NEMA TT-30R RV Receptacle

Standard RV connector.

### 9. AC 20A Circuit Breakers

### 10. AC 120V NEMA 5-20R Duplex Receptacles (20A)

Standard household outlets.

### 11. DC 10A Circuit Breaker

Thermal protector that protects the DC 12V receptacle from overload.

### 12. DC 12V Receptacle

### 13. CO WATCHDOG Carbon Monoxide Monitor

Measures the accumulation of poisonous CO gas while the generator is running. If the level of CO gas gets too high, the CO Watchdog system will automatically shut down the generator.



# UNPACKING & PACKING LIST

## UNPACKING

With the help of a friend or trustworthy foe, such as one of your in-laws, carefully remove the generator from the packaging and place it on a sturdy, flat surface. Make sure to take out all contents and accessories. Do not discard the packaging until everything is removed. Check the packing list below to make sure you have all of the parts and accessories. If any part is missing or broken, please contact customer service at **1-847-429-9263** (M-F 8-5 CST), or email [techsupport@wenproducts.com](mailto:techsupport@wenproducts.com).

**IMPORTANT:** Two red shipping brackets have been added to the bottom of your generator to protect the generator during shipping. Please make sure to remove BOTH shipping brackets before operation. Make sure there is no gasoline or oil in the generator, and carefully tip the generator on its end for easier access to the brackets.

## PACKING LIST

Components	Qty.
Generator	1

Tools & Accessories	Qty.
Funnel	1
Wrench 10mm/12mm	1
Wrench 13mm/16mm	1
Screwdriver	1
Spark Plug Socket	1
Engine Oil	1
LPG Pressure Reducing Valve 1.5m	1

Handle Kit	Qty.
Nut M8	2
Bolt, M8x40	2
Handle Plug	2
Handrail Jacket	2
Washer	4
Push Handle	2

Support Bracket	Qty.
Bolt, M8x16	2
Support Bracket	1

Wheel Kit	Qty.
Pin, $\phi$ 16x85	2
Wheel	2
Circlip	2



## ASSEMBLY & ADJUSTMENTS

### TO INSTALL THE SUPPORT BRACKET:

The support bracket (Fig. 1 - 1) comes with the two feet (Fig. 1 - 2) pre-installed with two hex nuts (Fig. 1 - 3) and two hex bolts (Fig. 1 - 4). Attach the support bracket (Fig. 1 - 1) to the frame of the generator using the two included M8x16 bolts (Fig. 1 - 5).

**NOTE:** The support bracket is mounted to the bottom bracket opposite the side of the wheel bracket (Fig. 1 - 9).

### TO INSTALL THE WHEELS:

Slide the wheel axle (Fig. 1 - 6) through the wheel (Fig. 1 - 7) and wheel bracket (Fig. 1 - 8) on the frame. Insert the circlip (Fig. 1 - 9) through the hole on the end of the axle to keep the wheel in place. Repeat for the other wheel.

### TO INSTALL THE HANDLES:

Assemble the handle by connecting the handle grip (Fig. 1 - 10) to the bottom of the handle (Fig. 1 - 11) and the handle plug (Fig. 1 - 12) to the top of the handle as shown in Fig. 1. Repeat for the other handle. Attach the handle assembly to the frame of the generator (Fig. 1 - 13) using the included M8x40 bolt (Fig. 1 - 14), two washers (Fig. 1 - 15), and M8 nut (Fig. 1 - 16). Repeat for the other handle.

**NOTE:** The handles are installed on the opposite side of the generator frame from the wheels.

**NOTE:** Make sure that both washers are installed inside of the handle assembly as shown in Fig. 1.

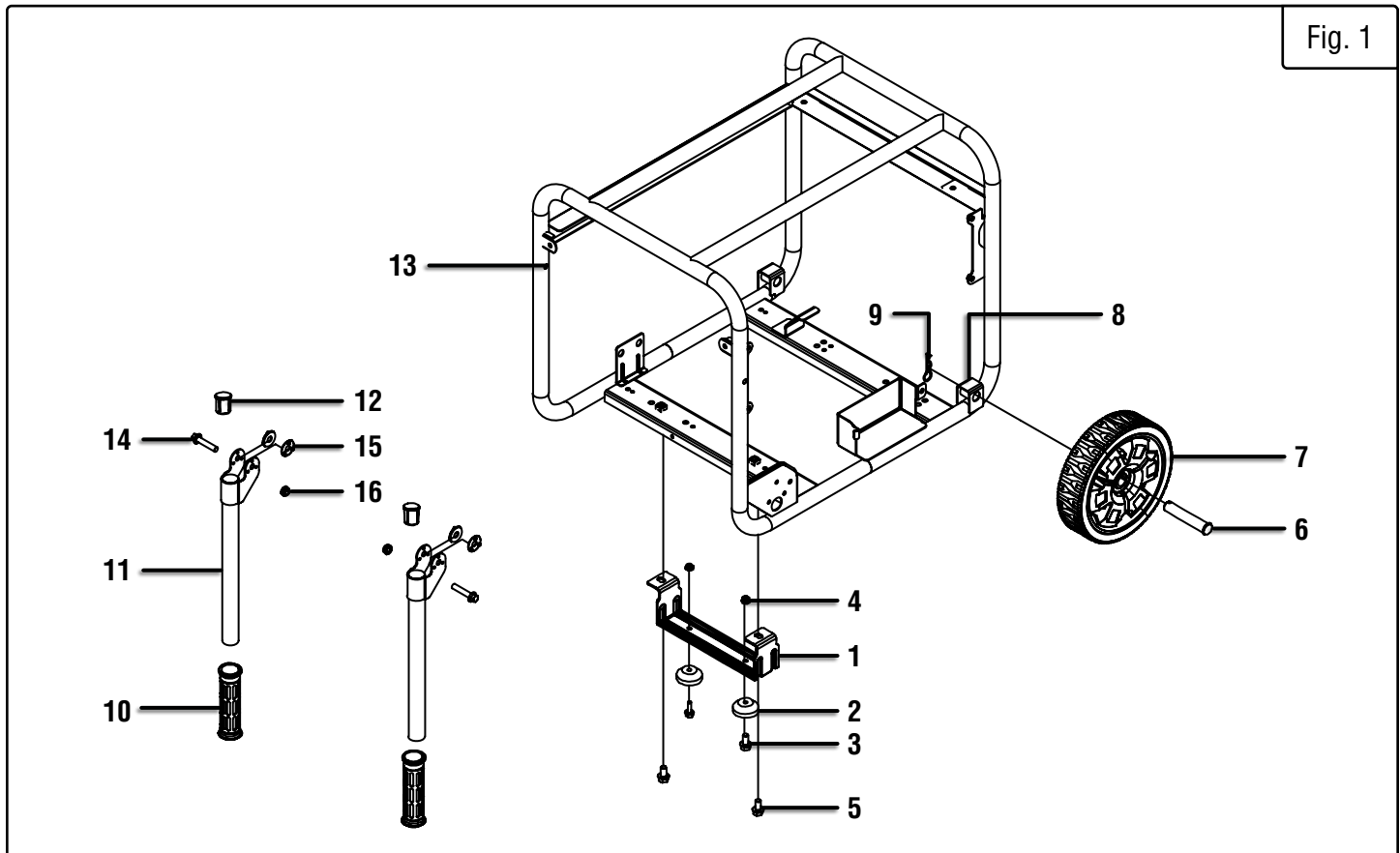

**NOTE:** Only the generator frame is shown to maximize clarity for assembly.

# GENERATOR PREPARATION

The following section describes the necessary steps to prepare the generator for use. If you are unsure about how to perform any of the steps please call **1-847-429-9263** (M-F 8-5 CST) for customer service. Failure to perform these steps properly can damage the generator or shorten its life.

## STEP 1 - ADD/CHECK OIL

The generator is shipped without oil. User must add the proper amount of oil before operating the generator for the first time. The oil capacity of the engine's crankcase is **33.8 fl. oz.** (1.0 L).

### ENGINE OIL RECOMMENDATIONS

Select good quality detergent oil bearing the American Petroleum Institute (API) service classifications SJ, SL, or SM (synthetic oils may be used). Select the SAE viscosity grade of oil that matches the expected operating temperature.

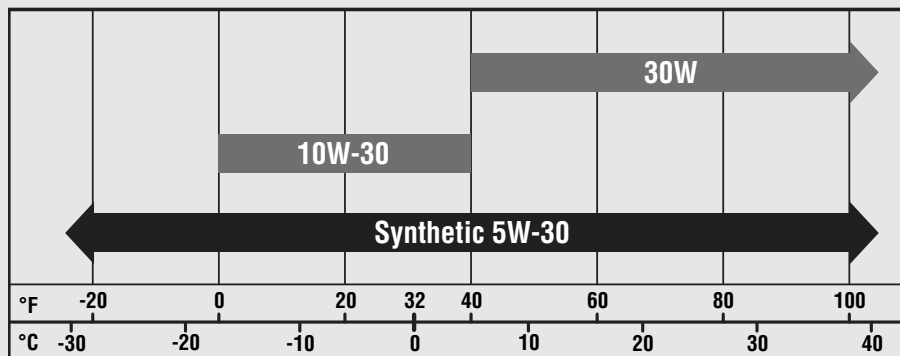

Fig. 2

- **30W Engine Oil**  
Temperatures above 40°F
- **10W-30 Engine Oil**  
Temperatures between 0°F - 40°F
- **Synthetic 5W-30 Engine Oil**  
All temperature ranges

### TO ADD OIL:

1. Place the generator on a level surface. Make sure the engine is OFF before adding or checking oil.

**CAUTION!** Keep the generator level. Tilting the generator to assist in filling will cause oil to flow into the wrong areas of the engine and cause damage.

2. Unscrew the oil dipstick (Fig. 3) from the engine.
3. Using an oil funnel or appropriate dispenser, slowly add oil into the oil fill, being careful not to overfill the unit. Fill the crankcase to the upper fill line so you can visually see the oil coming halfway up the oil fill threads. See Fig. 4.
4. Reinstall the oil dipstick and firmly tighten it. Wipe clean any spilled oil.

**NOTE:** Extend the lifespan of your generator by catching the loose metal filaments that naturally build up inside the crankcase with the WEN Magnetic Dipstick (**Model 55201**), available for purchase at [wenproducts.com](http://wenproducts.com).

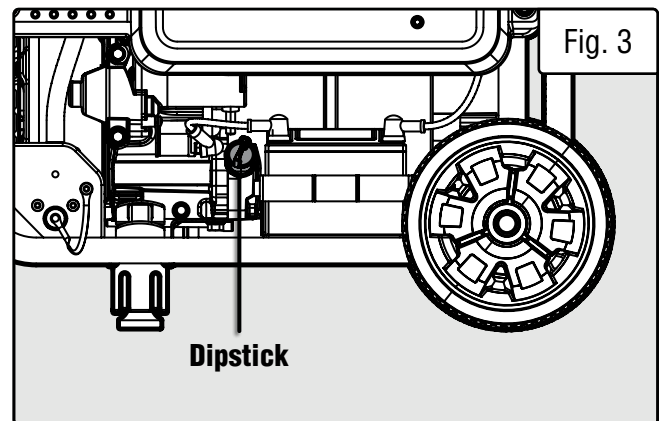

Fig. 3

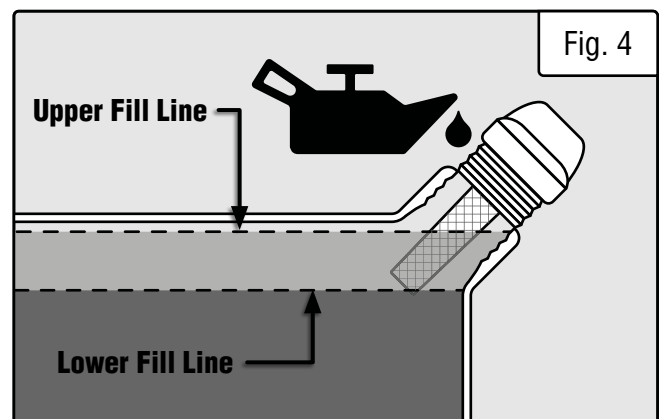
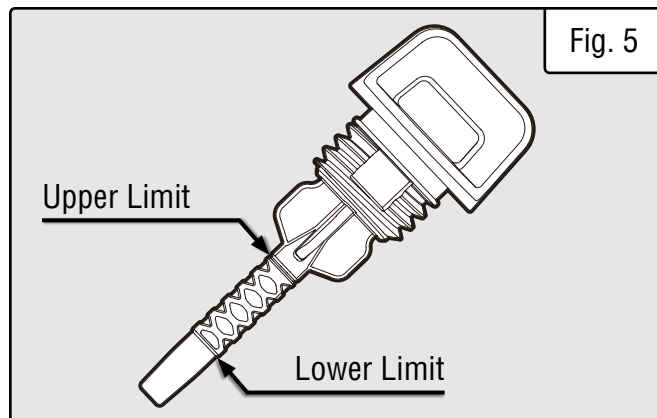

Fig. 4

## GENERATOR PREPARATION

### TO CHECK OIL LEVEL (before every subsequent start):

1. Place the generator on a level surface. Make sure the engine is OFF before adding or checking oil.
2. Remove and wipe the dipstick with a clean rag.
3. Insert the dipstick into the oil fill without screwing it in. Remove the dipstick to check the oil mark.
4. If the oil mark covers **less than one half** of the dipstick, slowly **add oil** until the oil mark reaches the top of the dipstick (or when you can see the oil coming halfway up the oil fill threads). See Fig. 5.



### OIL LEVEL SHUTDOWN

To protect the unit from damage, the generator is equipped with a low-oil-pressure shutoff that will automatically shut down the engine when the oil level is too low. The oil level of the engine should be checked before each start to ensure that the engine crankcase contains sufficient lubricant.

## STEP 2 - ADD/CHECK FUEL

### FUEL OPTION A: GASOLINE

**⚠ WARNING: RISK OF EXPLOSION. HIGHLY FLAMMABLE:** This generator may emit highly flammable and explosive gasoline vapors, which can cause severe burns or even death, if ignited. A nearby open flame can lead to explosion even if not directly in contact with gasoline.

- Do not operate near open flame, heat, or any other ignition source. Do not smoke near the generator.
- Always operate on a firm, level surface.
- Always turn generator off before refueling. Allow generator to cool for at least 2 minutes before removing fuel cap. Loosen cap slowly to relieve pressure in tank.
- Do not overfill fuel tank. Gasoline may expand during operation. Do not fill to the top of the tank. Allow for expansion. Always check for spilled fuel before operating.
- If fuel spills, move the generator at least 30 feet away from the spill and wipe clean any spilled fuel before starting the engine.
- Empty fuel tank before storing or transporting the generator.

**ONLY** use fresh (within 30 days from purchase), lead-free gasoline with a **minimum of 87 octane rating**. The generator performs best with ethanol-free gasoline. **DO NOT** use gasoline with over 10% ethanol.

The capacity of the fuel tank is **2.9 US gallons (11.0 L)**. Do not mix oil with gasoline.

**Follow the instructions on the next page to add gasoline.**

### IMPORTANT:

- Avoid getting dirt or water into the fuel tank.
- Keep gasoline away from sparks, open flames, pilot lights, heat, and other sources of ignition.
- Gasoline can age in the tank and make starting difficult. Never store the generator for more than 2 months with fuel in the tank.
- Never use an oil/gasoline mixture.
- Never use old gasoline.

## GENERATOR PREPARATION

### TO ADD GASOLINE:

1. Place the generator on a level surface. Make sure the engine is OFF before adding or checking the fuel.
2. Unscrew the fuel cap (Fig. 6) and set it aside. The fuel cap may be tight and hard to unscrew.
3. Slowly add unleaded gasoline to the fuel tank. Be careful not to overfill. Reinstall fuel cap and wipe clean any spilled gasoline with a dry cloth.

**NOTE:** Do not fill the fuel tank to the very top. If you do so, gasoline will expand and spill during use, even with the fuel cap in place.

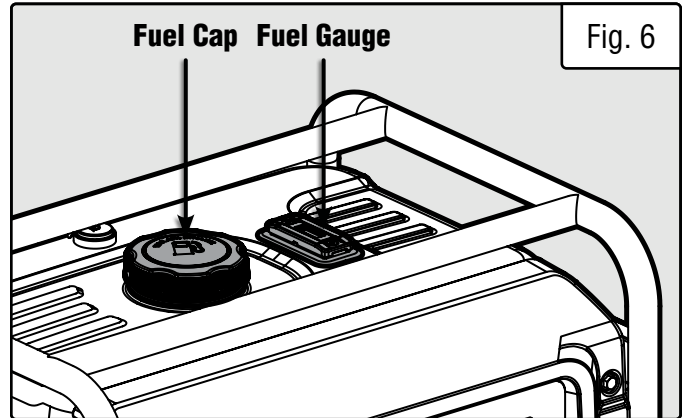

### TO CHECK GAS LEVEL (before every subsequent start):

1. Before starting the generator, check the fuel gauge (Fig. 6) to see if there is sufficient fuel inside the tank:
  - **E** = Empty
  - **F** = Full
2. If the tank is empty, add gasoline to the fuel tank. See above section, "To Add Gasoline".

**⚠ WARNING!** If using gasoline, the LPG tank must be shut OFF. If using LPG, the fuel valve on the generator must be turned to the OFF position.

### FUEL OPTION B: LIQUID PETROLEUM GAS (LPG)

**⚠ DANGER!** Explosion and fire. LP vapors are extremely flammable and explosive. Do not use or store LP cylinder in a building, garage or enclosed area. Failure to do so will result in death or serious injury.

**⚠ WARNING!** Explosion and fire. The cylinder valve should be turned OFF (closed) when generator is not in use. Failure to do so could result in death or serious injury.

- Always keep the LPG cylinder in an upright position.
- When transporting and storing, keep cylinder secured in an upright position with cylinder valve turned off. Keep cylinders ventilated and away from heat when in a vehicle.
- Liquid Petroleum Gas (LPG) is highly flammable and explosive. Flammable gas under pressure can cause a fire or explosion if ignited.
- In any petroleum gas fire, flames should not be extinguished unless the fuel supply valve is turned OFF. If a fire is extinguished and a supply of fuel is not turned OFF, an explosion hazard could be created.
- **RISK OF BURNS.** Contact with liquid contents of cylinder will cause freeze burns to the skin. If liquid contents contacts skin or eyes, seek immediate medical attention.
- When exchanging LPG cylinders, be sure the cylinder valve is of the same type.

# GENERATOR PREPARATION

## FUEL OPTION B: LIQUID PETROLEUM GAS (LPG) (CONT.)

**NOTE:** LPG regulator inlet pressure is approximately 30 PSI at 0 °F, and 218 PSI at 100 °F.

- You can use LPG tanks with Type 1, right hand Acme threads with this generator. Verify that the qualification date on tank has not expired. Do not use rusted or damaged cylinders.
- All new cylinders must be purged of air and moisture prior to filling. Used cylinders that have not been plugged or kept closed must also be purged.
- The purging process should be done by the propane gas supplier. (Cylinders from an exchange supplier should have been purged and properly filled by supplier).

### To connect your generator to an LPG cylinder:

1. Take off the safety caps from the cylinder valve, generator-mounted regulator, and regulator connecting hose ends.
2. With the LPG tank closed, attach the first-stage regulator to the valve. Turn the regulator's plastic coupling right (clockwise) to tighten the assembly onto the LPG tank (Fig. 7).
3. Connect the other end of the hose to the generator's onboard regulator with a 3/4 in. (19mm) wrench (not supplied) (Fig. 8).
4. Turn the LPG tank valve ON (Fig. 9) and check for leaks by spraying soapy water to check the connections. If bubbles appear, become larger in size, or increase in number, a leak exists. This must be corrected before using the generator. Contact your local Independent Authorized Service Dealer (IASD) for assistance.

**NOTE:** You can use Teflon (or other tape) to help seal the connection between the regulator hose and the generator.

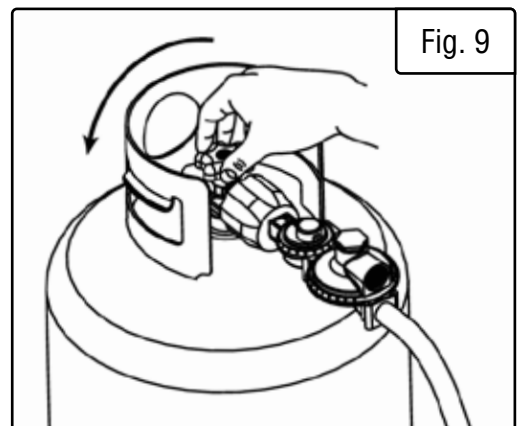
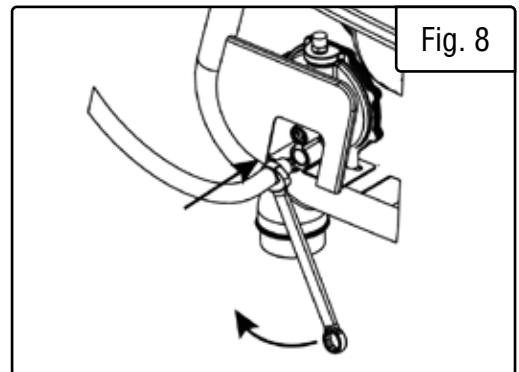
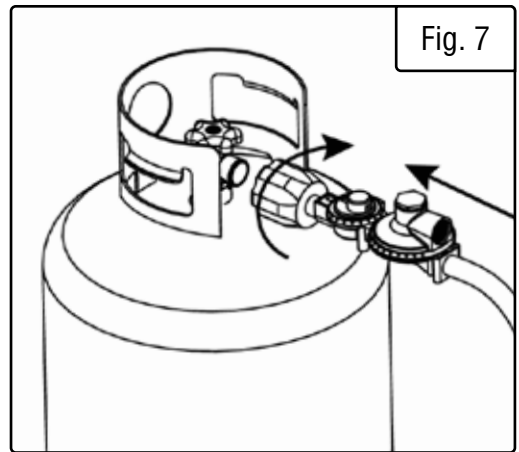

**⚠ CAUTION!** Always position the LPG cylinder so the connection between the valve and regulator won't cause sharp bends or kinks in hose.

**⚠ WARNING!** Risk of burns. Contact with liquid contents of cylinder will cause freeze burns to the skin. If liquid contents contacts skin or eyes, seek immediate medical attention.

**⚠ WARNING!** When transporting and storing, keep cylinder secured in an upright position with cylinder valve turned off. Keep cylinders ventilated and away from heat when in a vehicle.

# GENERATOR PREPARATION

## STEP 3 - CONNECT THE BATTERY

**⚠ WARNING!** BATTERY GIVES OFF EXPLOSIVE HYDROGEN GAS.

- Keep battery away from spark, flame, or cigarette.
- Do not connect or disconnect battery while generator is running.
- Service or use battery only in well ventilated areas.

**⚠ WARNING!** Battery contains sulfuric acid. Battery acid is poisonous. Tilting the generator with the battery installed can cause battery acid to spill.

- Wear protective clothing and eye wear when servicing battery.
- Keep out of reach of children.
- Do not tilt generator with battery installed.
- If battery acid gets on your skin, wash with water immediately.
- If battery acid gets in your eyes, flush with water for at least 15 minutes and call a doctor immediately.

If battery acid is swallowed, call a doctor immediately. Drink a large amount of water or milk. Then drink milk of magnesia or vegetable oil.

The generator comes with the battery disconnected for safety. When using gasoline to run the generator, the battery must be connected whether using electric or recoil start. The battery must also be connected for electric start when using LPG, but the battery does not need to be connected for recoil start on LPG.

### To connect the battery:

1. Remove the red cover from the positive (+) battery terminal.
2. Connect the red cable to the positive (+) battery terminal with the suitable nuts and bolts.
3. Make sure connections are secure and slide the rubber boot over the positive (+) battery terminal and connection hardware.
4. Connect the black cable to the negative (-) battery terminal with the suitable nuts and bolts. (This has already been done for the battery included with the generator.)
5. Make sure all connections are secure and slide the rubber boot over the negative (-) battery terminal and connection hardware.

**IMPORTANT:** If you do not plan to use the generator for an extended period of time, it is recommended to DISCONNECT the negative battery cable from the battery to protect the battery from losing charge. After disconnecting the cable, cover the free end with an insulator such as electrical tape.

If the battery is dead or disconnected, the generator will not start when using gasoline, or when using LPG and electric start. The battery receives charge when the generator is running. To help maximize your battery's lifespan, and ensure it's ready when needed, run your generator once a month, disconnect the negative battery cable as outlined above, or connect the battery to a trickle charger.

## GENERATOR PREPARATION

### STEP 4 - GROUND THE GENERATOR

To reduce the risk of electric shock and to maximize safety, the generator should be properly grounded.

Ground the generator by tightening the grounding nut on the front control panel (Fig. 10) against a grounding wire. A generally acceptable grounding wire is a **No. 12 AWG (American Wire Gauge) stranded copper wire**.

This grounding wire should be connected at the other end to a copper, brass, or steel-grounding rod that is driven into the earth. Wire and grounding rods are not included with the generator.

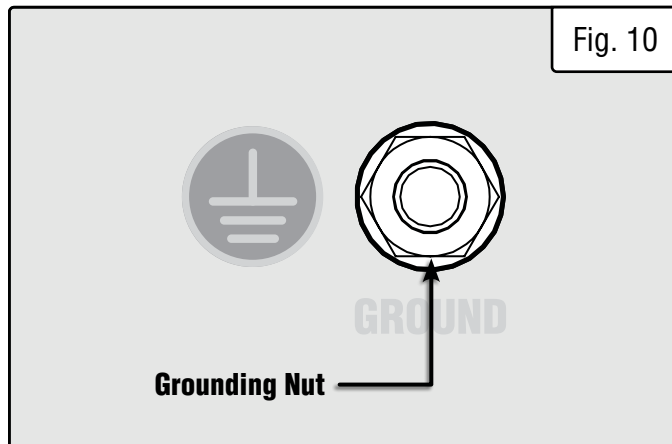

**NOTE:** Grounding codes can vary by location. Contact a local electrician to check the area codes.

**⚠ WARNING!** Failure to properly ground the generator increases your risk of electric shock.

### HIGH ALTITUDE OPERATION ABOVE 2000 FEET

The fuel system on this generator may be affected by operation at high altitudes. Proper operation can be ensured by installing an altitude kit at altitudes higher than 2000 feet above sea level. At elevations above 7000 feet, the engine may experience a decrease in performance, even with the proper altitude kit. Operating this generator without said kit may increase the engine's emissions and decrease both fuel economy and performance.

**NOTE:** If you plan to only use propane at high altitudes, a high-altitude kit is not required. High-altitude kits are only required if you plan to use gasoline at high altitudes.

This kit should be installed by a qualified mechanic. Contact customer service at **1-847-429-9263** (M-F 8-5 CST), or email **techsupport@wenproducts.com** for information about service centers near you. You can order the kit at **wenproducts.com** by searching part number **DF623X-HA36** or **DF623X-HA68**. Refer to the instructions included with your altitude kit for more information about installation.

**⚠ WARNING!** To prevent serious injury from fire, follow the kit installation procedures in a well-ventilated area away from ignition sources. If the engine is hot from use, shut the engine off and wait for it to cool before proceeding. Do not smoke near the generator. Warranty will be void if adjustments are not made for high altitude use.

**CAUTION:** Engines with the high-altitude kit installed operated at lower altitudes could cause severe engine damage and affect emissions compliance. Be sure to uninstall the high altitude kit when operating at altitudes below 2000 feet.

**After completing the above preparation, the generator is ready to be started.**



## STARTING THE GENERATOR

Before starting the generator, make sure you have read and performed the steps in the “Generator Preparation” section of this manual. If you are unsure about how to perform any of the steps in this manual please call **1-847-429-9263** (M-F 8-5 CST) for customer service.

### **DANGER: CARBON MONOXIDE**

Using a generator indoors **CAN KILL YOU IN MINUTES**. Generator exhaust contains carbon monoxide (CO). This is a poison gas you cannot see or smell. If you can smell the generator exhaust, you are breathing CO. But even if you cannot smell the exhaust, you could be breathing CO.

**NEVER** use a generator inside homes, garages, crawl spaces, or other partially enclosed areas. Deadly levels of carbon monoxide can build up in these areas. Using a fan or opening windows and doors does NOT supply enough fresh air. **ONLY** use a generator outside and far away from windows, doors, and vents. These openings can pull in generator exhaust.

Even if you use a generator correctly, CO may leak into the home. **ALWAYS** use a battery-powered or battery-backup CO alarm in the home. If you start to feel sick, dizzy, or weak after the generator has been running, move to fresh air **RIGHT AWAY**. See a doctor. You may have carbon monoxide poisoning.

 **WARNING:** The exhaust from this product contains chemicals known to the State of California to cause cancer, birth defects, or other reproductive harm.

 **WARNING:** Do not operate generator near open flame or flammable materials. This generator may emit highly flammable and explosive gasoline vapors, which can cause severe burns or even death if ignited. A nearby open flame can lead to explosion even if it isn't directly in contact with gasoline. Do not smoke near the generator.

 **WARNING:** This generator produces powerful voltage, which can result in electrocution.

 **WARNING:** Do not use in rainy or wet conditions. Do not touch bare wires or receptacles (outlets). Do not allow children or non-qualified persons to operate.

 **WARNING:** Generator should only be connected to electrical devices, either directly or with an extension cord. **NEVER** connect to a building electrical system unless a qualified electrician has connected the generator to a transfer switch as a separately derived system. Such connections must comply with local electrical laws and codes. Failure to comply can create a back-feed, which may result in serious injury or death to utility workers.

To maximize safety, **ALWAYS** ground the generator before using it. Refer to "Step 4 - Ground The Generator."

Use a ground fault circuit interrupter (GFCI) in highly conductive areas such as metal decking or steel work. GFCIs are available in-line with some extension cords.

**CAUTION!** Disconnect all electrical loads from the generator before attempting to start it.

**Follow the instructions on the next page to start your generator.**



# STARTING THE GENERATOR

## BEFORE STARTING THE GENERATOR

1. Verify that the generator is outside on a dry, level surface. Allow at least two feet of clearance on all sides.
2. To maximize safety, check that the generator is properly grounded (see “Ground the Generator”).
3. Check there is sufficient level of oil in the crankcase. Add oil if necessary (see “Add/check Oil”).
4. Verify the fuel selection dial is turned to the desired fuel. Turn the dial to the “GASOLINE” position for gasoline and the “PROPANE” position for LPG. Check that there is adequate supply of the selected fuel.
5. Make sure all electrical devices are unplugged from the generator during ignition. Otherwise it will be difficult for the engine to start.

## STARTING THE GENERATOR

1. To use gasoline, turn the fuel valve to the ON position (Fig. 11). To use LPG, make sure all of the LPG connectors and hoses are well connected and sealed. Close the fuel valve, then open the LPG tank valve.
2. Move the choke lever (Fig. 12 - 1) to the CLOSE/START position.
3. Turn the fuel selector switch to “GASOLINE”.
4. Make sure the battery is connected. See p. 18 for more information.

### Gas Operation Start Up:

#### a. To start the engine with electric starter:

5. Press the engine start switch.
6. Slowly move choke lever to the OPEN/RUN position. If engine fires, but does not continue to run, move choke lever to CLOSE/START position and repeat starting instructions.

### LPG Operation Start Up:

1. Connect the LPG regulator hose to the tank and inlet on the generator.
2. Turn the LPG tank valve to the ON position.
3. Ground the generator.
4. Turn the fuel valve to the OFF position.
5. Turn the fuel selector switch to PROPANE.
6. Move choke lever (Fig. 12 - 1) to the START position.
7. Pull recoil 1-3 times to prime the engine.
8. Move choke lever to the RUN position.
9. Press the engine switch to start the engine.
10. Connect electrical devices.

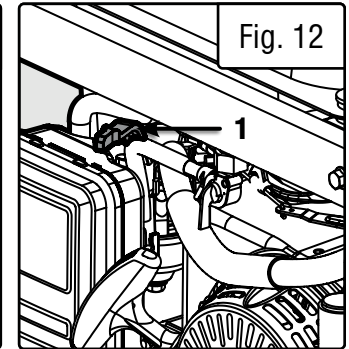
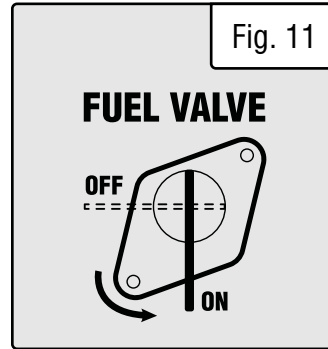

**⚠ WARNING!** The LPG cylinder valve must be shut OFF when using gasoline. The generator's fuel valve must be shut OFF when using LPG.

#### b. To start the engine with recoil starter:

5. Pull on the recoil starter handle slowly until a slight resistance is felt, then pull quickly to start the engine. Return cord gently into the recoil starter. Never allow the cord to snap back.

If the engine fails to start, repeat this step.

6. Once the engine has started, slowly return the choke lever all the way to the OPEN/RUN position.
7. Connect electrical devices.

**NOTE:** Allow the engine to run for several minutes before attempting to connect any electrical devices. This allows the generator to stabilize its speed and temperature. Follow the instructions in the next section for properly connecting your electrical devices.

**NOTE:** In case you have had repeated failed attempts to start the engine, please consult the troubleshooting guide before attempting to start the generator. If problems persist please call **1-847-429-9263**, M-F 8-5 CST.

# USING THE GENERATOR

## CALCULATING THE WATTAGE OF YOUR DEVICE(S)

Connect electrical devices running on AC current according to their wattage requirements. Calculate the total running wattage and starting wattage of the device(s) you wish to connect, and MAKE SURE that they are within the capacity of your generator and the capacity of each individual outlet.

<b>Generator Wattage Capacity</b>	<b>Generator Running (Rated) Watts</b>	<b>Generator Starting (Surge) Watts</b>
	<b>Gasoline: 5000W</b>	<b>Gasoline: 6250W</b>
	<b>LPG: 4500W</b>	<b>LPG: 5625W</b>
	<p><b>What this means:</b> The generator can produce a maximum of 5000W/4500W on a continuous basis to supply ongoing power to your electronic devices.</p> <p><b>NOTE:</b> Also check the rated amperage for each outlet and make sure not to overload the individual outlets.</p>	<p><b>What this means:</b> Some devices such as box fans require short bursts of extra power in addition to the rated wattage listed by the device to start their motors.</p> <p>The generator can produce a maximum wattage of 6250W/5625W for a short period of time (seconds) to cover the extra starting power required by your electronic devices.</p>
<b>Electronic Device Wattage Calculation</b>	<p>Find the wattage information of each device you plan to connect. The information should be listed on the device or in its instruction manual.</p> <p style="text-align: center;">The wattage can be calculated using this equation: <b>Watts = Volts x Amperes</b></p>	
	<p><b>To calculate the total running watts of your devices:</b></p> <p>+ Add up the running wattages of all the device(s) you plan to connect</p> <p>= The total running wattage</p> <p>This wattage should NOT exceed the running wattage of <b>5000W/4500W</b>.</p> <p>It is recommended to maintain a load at or below 4500W/4050W (90% of the rated output) to ensure steady voltage output and to prolong the generator's lifespan.</p>	<p><b>To calculate the total starting watts of your devices:</b></p> <p>+ Add up the total running wattage of all the device(s) you plan to connect</p> <p>+ Add the single highest ADDITIONAL starting wattage out of the device(s) you plan to connect</p> <p>= The total surge (starting) wattage</p> <p>This wattage should NOT exceed the starting wattage of <b>6250W/5625W</b>.</p>
	<p>If any of either of the total calculated running watts or starting watts is higher than the capacity of your generator, adjust the load until both wattage requirements are met. Otherwise you will overload the generator, and cause damage to the engine and your electrical device(s).</p>	

## **USING THE GENERATOR**

### **CALCULATING THE WATTAGE OF YOUR DEVICE(S) - CONTINUED**

The chart below serves as a reference for the estimated wattage requirements of common electrical devices. However, do not solely rely on this chart - all electronics and appliances are built differently. Always check the wattage listed on the electrical device before consulting this chart.

<b>Tool or Appliance</b>	<b>Rated (Running) Watts</b>	<b>Surge (Starting) Watts</b>
Hot Plate	2500	0
Saw - Radial Arm	2000	2000
Electric Stove (Each Element)	1500-2800	0
Saw - Circular	1500	1500
Air Compressor (1 HP)	1500	3000
Window Air Conditioner	1200	1800
Saw - Miter	1200	1200
Microwave	1000	0
Well Water Pump	1000	1000
Sump Pump	800	1200
Refrigerator Freezer	800	1200
Furnace Blower	800	1300
Computer	800	0
Electric Drill	600	900
Television	500	0
Deep Freezer	500	500
Garage Door Opener	480	0
Stereo	400	0
Box Fan	300	600
Clock Radio	300	0
Security System	180	0
DVD Player / VCR	100	0
Common Light Bulb	75	0

Table 2 - Estimated Wattages of Common Electrical Appliances

**NOTE:** Become familiar with the functions and capacity of each component on the control panel before connecting electrical devices. See page 11 for more information about the components of the control panel. Do not overload generator or individual panel receptacles. Do not connect 50Hz or 3-phase loads to the generator.

# USING THE GENERATOR

## CONNECTING ELECTRICAL DEVICES

**CAUTION:** Become familiar with the functions and capacity of each component on the control panel (page 11) before connecting electrical devices. Do not overload generator or individual panel receptacles. Do not connect 50Hz or 3-phase loads to the generator.

**Follow the steps below to properly connect your device(s) to the generator:**

1. Before connecting electrical devices, allow the generator to run for a few minutes to stabilize the speed and voltage output.
2. Select the device with the highest wattage, and make sure it is turned off. Plug the device into the matching generator outlet and then turn the device on. Allow the engine to stabilize.
3. Repeat step 2 to plug in each additional device. Do not attempt to plug in or start multiple devices at the same time.

## IN CASE OF OVERLOAD

If your generator becomes overloaded from too much drawn wattage, the push-to-reset circuit breaker(s) on your control panel will activate and cut off the output. When an overload occurs, reduce the load by turning off and unplugging your electronic device(s), then press the activated circuit breaker to reset your generator. If the circuit breaker does not reset, wait several minutes and try again. If no power is produced after resetting, restart your generator.

## SOME NOTES ABOUT POWER CORDS

Long or thin extension cords can drain the power provided to your electrical devices. Refer to the following chart in determining the necessary gauge extension cord for each of your devices. Round up to the higher amperage in the chart to maximize safety.

Device Requirements			Max. Cord Length (ft) by Wire Gauge				
Amps	Watts (120V)	Watts (240V)	#8 wire	#10 wire	#12 wire	#14 wire	#16 wire
2.5	300	600	NR	NR	NR	375	250
5	600	1200	NR	NR	300	200	125
7.5	900	1800	NR	350	200	125	100
10	1200	2400	NR	250	150	100	50
15	1800	3600	NR	150	100	65	NR
20	2400	4800	175	125	75	50	NR
25	3000	6000	150	100	60	NR	NR
30	3600	7200	125	65	NR	NR	NR
40	4800	9600	90	NR	NR	NR	NR

\*NR = Not Recommended

Table 3 - Power Cord Requirement Guide

**⚠ WARNING!** Generator should **only** be connected to electrical devices, either directly or with an extension cord. NEVER CONNECT TO A BUILDING ELECTRICAL SYSTEM unless a qualified electrician has connected the generator to a transfer switch as a separately derived system. Such connections must comply with local electrical laws and codes. Failure to comply can create a back-feed, which may result in serious injury or death.

## USING THE GENERATOR

### CO SENSOR INFORMATION

The CO Watchdog carbon monoxide monitoring system (Fig. 13 - 1) measures the accumulation of poisonous CO gas while the generator is running. If the level of CO gas gets too high, the CO Watchdog system will automatically shut down the generator. **This system is not a substitute for an indoor CO alarm.**

Whenever the CO Watchdog system shuts down the generator, the LED on the generator control panel (Fig. 13 - 1) will **blink red** for at least 5 minutes after the generator is shut down. An LED on the sensor module itself will also start blinking red. **If you notice that the LED is blinking red, vacate the area immediately.** Go to an open, outdoor area. Ventilate the area around the generator thoroughly before returning. Let the generator stay shut down for a few minutes before restarting the engine. This should allow carbon monoxide to dissipate from the area. If you restart the generator and CO Watchdog detects that CO levels are still too high, it will shut down the generator again. If CO levels are low enough, the generator will run normally.

Ensure that the generator is located in an open outdoor area, with the exhaust pointing away from occupied structures, and pointing away from the prevailing winds, such that those winds do not blow engine exhaust towards the sensor module. If anyone experiences dizziness, headaches, nausea, fatigue, or other symptoms of CO poisoning, get to fresh air immediately and seek the attention of a qualified medical professional. Follow all other directions in this manual regarding the connection and disconnection of electrical devices when starting or shutting down the generator.

When starting the generator, the CO Watchdog LED on the panel may flash. This indicates that the system is running a self-test procedure, and does not indicate a problem.

If the CO Watchdog LED on the panel is **yellow**, a system error has occurred, or the CO sensor has reached the end of its life. Contact WEN customer service **1-847-429-9263**, M – F 8 – 5 CST, or **techsupport@wenproducts.com** for assistance.

#### When operating your generator, please note the following:

- The CO Watchdog does not discriminate in its input; any source of carbon monoxide in the area around the generator could cause it to activate. If the CO Watchdog LED is blinking red, safety measures should be taken immediately.
- Tampering with, disconnecting, or bypassing the CO sensor could cause hazardous conditions, including but not necessarily limited to injury or death, and will void your warranty. The generator will not run with the CO sensor disconnected or bypassed, or if the CO sensor indicates an error.
- The CO sensor has a lifetime of about 7 years, and is capable of monitoring its lifetime. If your generator shows an error light several years after purchase, it may be time to replace the CO sensor. Contact WEN customer service for assistance.

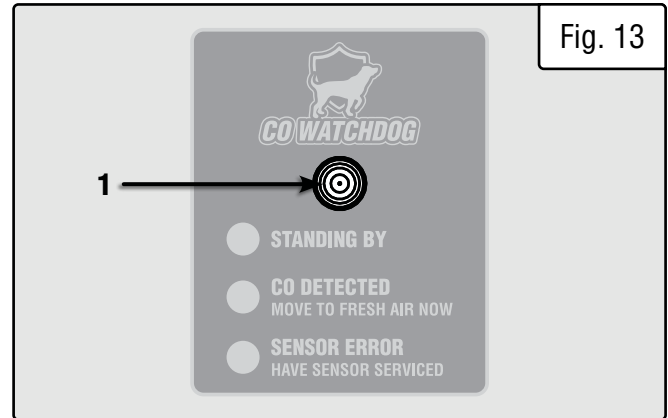

**NOTE:** if the generator is oriented so that the engine exhaust is blown towards the CO sensor, the generator may shut down.

## USING THE GENERATOR

### CHANGING FUELS

1. Before changing the fuel source, make sure the generator is turned off or running under half-load. Do not change fuel when generator is over half-load.

2. If switching from LPG to gasoline, turn off the LPG tank valve and disconnect LPG fuel tank from generator. Then turn ON the fuel valve.

If switching from gasoline to LPG, turn off the fuel valve. Then follow the LPG connecting procedure in section “FUEL OPTION B: Liquid petroleum gas (LPG)”.

3. Check the fuel level of the selected fuel and make sure there is an adequate amount.

4. Turn the fuel selector switch to the desired fuel; turn the dial to the “GASOLINE” position for gasoline and the “PROPANE” position for LPG.

## SHUTTING OFF THE GENERATOR

### TO STOP THE GENERATOR

1. Turn off all electrical devices prior to unplugging them from the generator. Unplugging running devices can cause damage to the generator. Never start or stop the generator with electrical devices plugged in or turned on.

2. Let engine run at no-load for several minutes to stabilize internal temperatures of engine and generator.

3a. If using **LPG**, make sure the fuel valve is off, turn the fuel selector switch to the “STORAGE” position. This is the final step.

3b. If using **gasoline**, turn the fuel valve to the OFF position. Let the generator run until the fuel is used up. Continue on to step 4.

4. Turn the fuel selector switch to the “STORAGE” position.

5. Drain the carburetor (See “Draining the Carburetor”).

**IMPORTANT:** Always ensure that the fuel valve and the engine switch are in the OFF position when the generator is not in use.

 **WARNING!** Allow the generator to cool down before touching areas that become hot during use.

**CAUTION:** Allowing gasoline to sit in the fuel tank for long periods of time can make it difficult to start the generator in the future. Never store the generator for extended periods of time (over 2 months) with fuel in the fuel tank. Refer to “Storing the Generator”.

# MAINTENANCE

## RECOMMENDED MAINTENANCE SCHEDULE

Proper routine maintenance of the generator will help prolong the life of the machine. Please perform maintenance checks and operations according to the maintenance schedule below, Table 4. If there are any questions about the maintenance procedures listed in this manual, please contact customer service at **1-847-429-9263** (M-F 8-5 CST), or email [techsupport@wenproducts.com](mailto:techsupport@wenproducts.com).

**⚠ WARNING!** Never perform maintenance operations while the generator is running. Before maintaining or servicing the generator, turn OFF the generator, disconnect all devices and allow the generator to cool down.

Recommended Maintenance Schedule		Every 8 Hours or Daily	Every 25 Hours	Every 3 Months or 50 Hours	Every 6 Months or 100 Hours	Before Storage	As Necessary
Engine Oil	Check Level	X					
	Replace		X*				X
Air Filter	Check			X*			
	Clean			X*			
Spark Plug	Check/Clean/Regap				X		
	Change				X		X
Fuel	Check Level	X					
	Drain					X	X
Carburetor	Drain	X					X
Spark Arrestor	Check/Clean				X		

\* Clean/change more often under dusty conditions or operating under heavy load.

Table 4 - Recommended Maintenance Schedule

### IMPORTANT GENERATOR MAINTENANCE TIPS:

- Drain your carburetor after each use and before storage to prevent it from clogging.
- Do not store the generator with fuel inside the tank for more than 2 months - the fuel will go bad.
- Run the generator for 20 to 30 minutes every month to maximize its lifespan.

**NOTE:** Failure to properly maintain the generator will void the warranty.

## MAINTENANCE

### CLEANING THE GENERATOR

Keep the generator clean to prevent improper operation or machine damage from dirt and debris. Inspect all ventilation openings on the generator. These openings must be kept clean and unobstructed.

If the generator becomes dirty, use a damp cloth to wipe exterior surfaces. Use a soft bristle brush to loosen dirt and oil and use a vacuum to pick up loose dirt. Use low pressure air (not to exceed 25 PSI) to blow away dirt.

**⚠ WARNING!** Never clean the generator when it is running! Never clean with a bucket of water or a hose. Water can get inside the working parts of the generator and cause corrosion or a short circuit.

### DRAINING THE CARBURETOR

**We recommend draining the carburetor after every use and before storing the generator.** Draining the carburetor can help prevent build-up and blockages caused by stagnant fuel inside of the carburetor.

1. Prepare an approved gasoline-storage container under the carburetor to collect the drained fuel.
2. The carburetor can be accessed from the backside of the generator between the engine and the air filter. To drain the carburetor, open up the carburetor drain screw (Fig. 14 - 1) with a Phillips-head screwdriver (not included) and drain out any gasoline that has built up inside.
3. Once the fuel has drained, close the drain screw.

**NOTE:** Make sure to drain your carburetor before storing the generator for long periods of time.

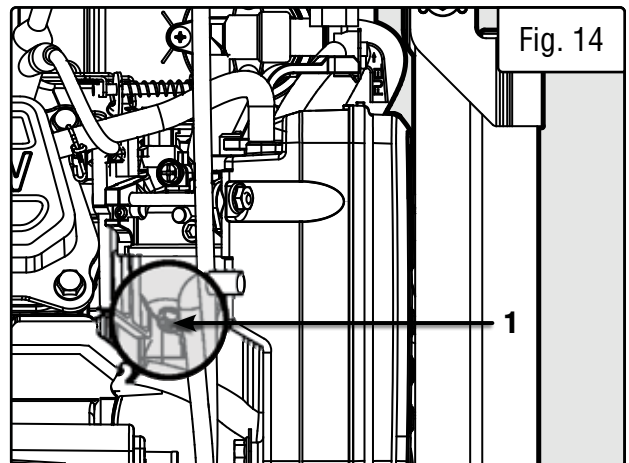



# MAINTENANCE

## CHECKING/ADDING OIL

**Check the oil level before each use and every 8 hours of operation.**

The oil capacity of the generator engine is **33.8 fl. ounces (1.0 L)**. Add oil when the oil level is low. For proper type and weight of oil refer to “add oil” portion of the “Generator Preparation” section. This is a critical step for proper engine starting. The generator is equipped with an automatic shutoff to protect it from running on low oil.

**To check the oil level and add oil:**

1. Make sure the generator is on a level surface. Do not tilt the generator, as oil will flow into engine areas and cause damage. Keep generator level!

2. Clean around the oil fill. Remove the dipstick and wipe the it with a clean rag.

3. Insert the dipstick into the oil fill opening without screwing in. Remove the dipstick to check the oil mark (Fig. 15). Add oil if the oil mark covers less than one half of the dipstick.

4. Using a funnel or appropriate dispenser, slowly add more oil. Repeat step 3 until the oil mark reaches the top of the dipstick (you can see oil coming up the threads of the oil fill). Do not over fill.

5. Reinstall dipstick and wipe clean any spilled oil with a rag. Reinstall the oil access cover.

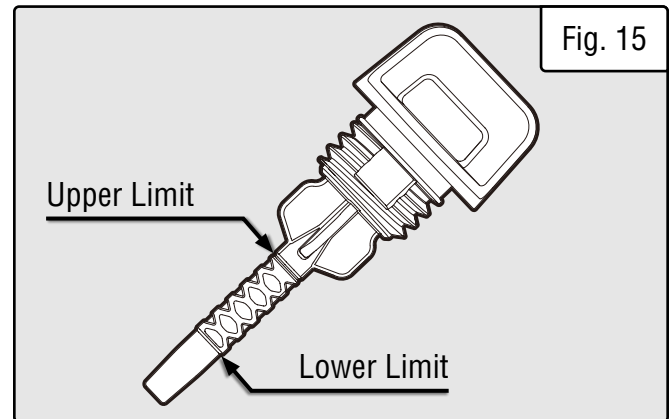

## DRAINING/CHANGING OIL

Change the oil according to the Recommended Maintenance Schedule.

Change the oil more often if operating under heavy load or high ambient temperatures. It is also necessary to drain the oil from the crankcase if it has become contaminated with water or dirt. Changing the oil when the engine is warm allows for complete drainage.

**To drain the oil from the generator:**

1. Place generator on elevated platform. Prepare an approved gasoline-storage container underneath the oil drain bolt next to the oil dipstick to catch the oil as it drains.

2. Unscrew the oil drain bolt (Fig. 16) and allow oil to drain from the engine completely.

3. Reinstall the oil drain bolt and tighten it securely. Wipe clean any oil spillage.

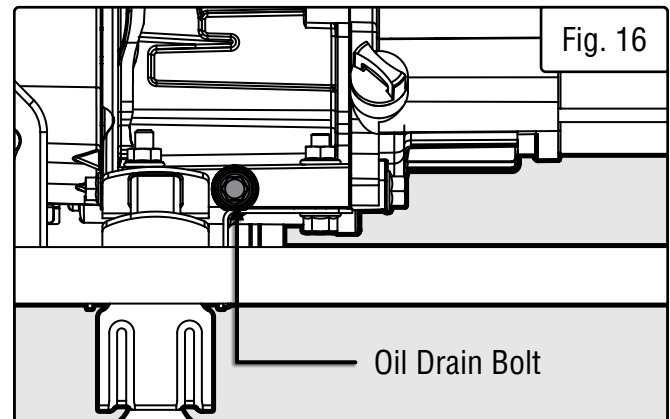

**NOTE:** Never dispose of used engine oil in the trash or down a drain. Please call a local recycling center or auto garage to arrange proper oil disposal.

# MAINTENANCE

## AIR FILTER MAINTENANCE

**Check every 50 hours of operation (refer to Recommended Maintenance Schedule).**

Routine maintenance of the air filter helps maintain proper airflow to the carburetor. Occasionally check that the air filter is free of excessive dirt. Clean air filter more frequently in dirty or dusty conditions

### To inspect and clean the air filter:

1. Remove the air filter cover (Fig. 17 - 1) by undoing the clasps at the top and bottom of the air filter cover.
2. Remove the sponge-like air filter element from the casing. Wipe excessive oil and any dirt from inside of the air filter casing.
3. Check and clean the foam air filter element. Good elements can be washed in soapy water. Dry the element in clean cloth (do not twist it). A small amount of oil left in the element is normal and necessary for the engine to work properly.

If the air filter element has been damaged, replace it with a new one. Replacement air filters can be ordered from **wenproducts.com** by searching **part no. 56500-134**.

4. Reinstall the air filter element and air filter cover.

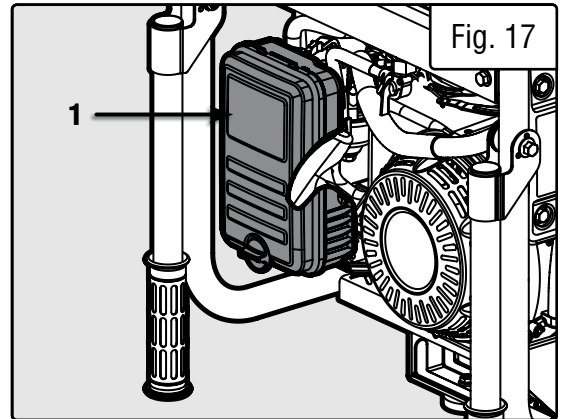

**⚠ WARNING!** Running the engine with a dirty, damaged or missing air filter element can result in danger to the operator and cause the engine to wear out prematurely.

## SPARK ARRESTOR MAINTENANCE

The spark arrestor is located outside the muffler, which gets very hot during operation. Allow the engine to cool completely before servicing the spark arrestor. To inspect and clean the spark arrestor:

1. Remove the screws holding the cover plate which retains the end of the spark arrestor to the muffler (Fig. 18 - 1).
2. Remove the spark arrestor screen.
3. Carefully clean and remove the carbon deposits from the spark arrestor screen with a wire brush. Replace the spark arrestor if it is damaged.
4. Reinstall the spark arrestor in the muffler and secure it in place with the screws.

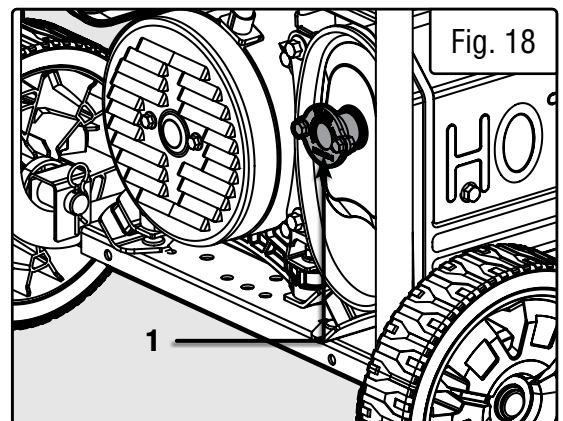

## SPARK PLUG MAINTENANCE

### Refer to Recommended Maintenance Schedule for maintaining the spark plug.

The spark plug is important for proper engine operation. Check the spark plug regularly to maintain proper engine operation. A good spark plug should be intact, free of deposits, and properly gapped.

### To inspect or replace the spark plug:

1. Pull on the spark plug boot to remove it (Fig. 19). Be careful not to tear insulation or wire.

2. Remove the spark plug rubber boot and unscrew the spark plug from the engine using the spark plug wrench provided.

**TIP:** There is limited space for the wrench to turn. Use both rows of holes in the spark plug wrench to gain leverage to loosen the plug.

3. Visually inspect the spark plug. If it is cracked or chipped, or if the electrodes are worn or burned, discard it and replace with a new spark plug.

We recommend replacing with an **Torch F7TC** spark plug (part no. **56500-123**), available for purchase at [wenproducts.com](http://wenproducts.com).

4. If re-using the spark plug, use a wire brush to clean any dirt from around the spark plug base, then re-gap the spark plug.

5. Measure the plug gap with a spark plug gap gauge. The gap should be **0.6 to 0.8 mm (0.024-0.031 in.)** (Fig. 20). Carefully adjust the gap if necessary.

6. Screw the spark plug back into the spark plug hole using the spark plug wrench. Do not over-tighten spark plug. Recommended tightening of spark plug is  $\frac{1}{2}$  to  $\frac{3}{4}$  of a turn (15 ft-lb torque/20.33 Nm) after spark plug gasket contacts spark plug hole.

7. Reinstall the spark plug boot over the spark plug.

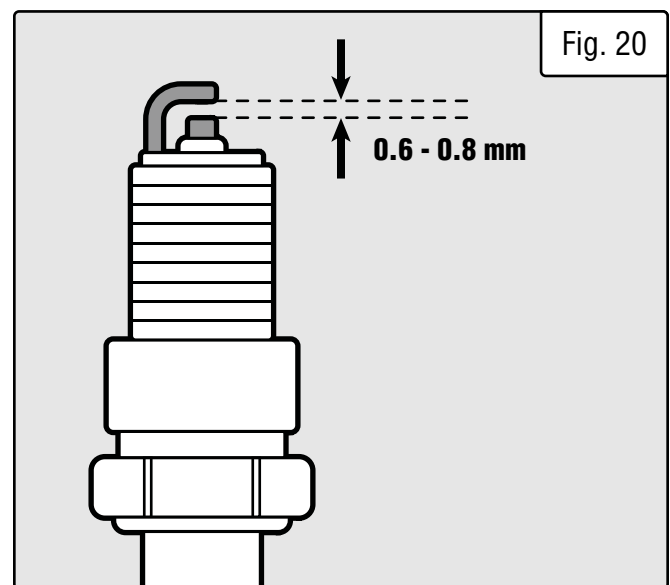
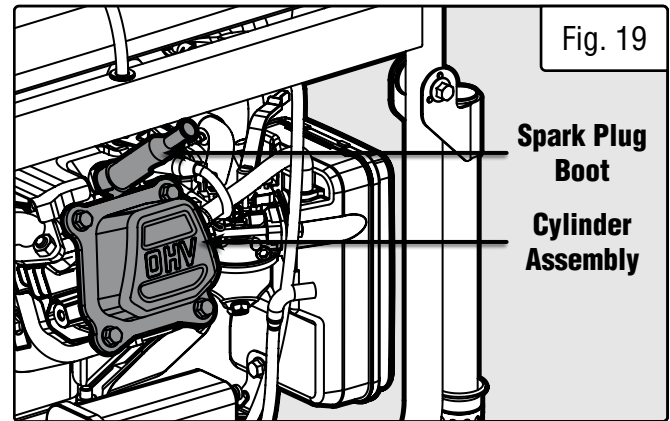

## BATTERY MAINTENANCE/STORAGE

The battery (**part no. DF623X-075**) shipped with the generator has been fully charged. The battery will receive charge when the engine is running. Remember to run the generator once a month for 20-30 minutes to charge the battery. A charged battery will allow you to start the generator using the electric start switch during your next time of need.

If the battery is out of charge, you can still manually start the generator using the recoil start with LPG as your fuel source.

**IMPORTANT:** If the generator is not used for a long period, it is recommended to disconnect the negative battery cable from the battery to protect the battery from losing charge. After disconnecting the cable, cover the free end with an insulator such as electrical tape. You may also connect the battery to an automatic trickle charger to keep the battery charged.

### To reinstall/replace the battery:

1. Disconnect the negative (-) battery terminal first (black wire).
2. Disconnect the positive (+) battery terminal second (red wire).
3. To install a new battery, install the hold down bracket, insert the threaded rod and tighten with M6 nuts.
4. Connect the positive (+) battery terminal (red wire) first. Slide rubber boot over the connection hardware.
5. Connect the negative (-) battery terminal (black wire) second. Slide rubber boot over connection hardware.

**NOTE:** Always recycle used batteries in accordance with local laws and regulations. Contact your local solid waste collection site or recycling facility to obtain information on local recycling processes.

## ***MAINTENANCE***

### **DRAINING THE FUEL TANK**

Drain and clean the fuel tank each year, or before storing the generator for longer than two months.

#### **To drain the fuel tank:**

1. Prepare an approved gasoline-storage container to collect the drained fuel. Place it near the fuel valve.
2. Turn the fuel valve to the OFF position.
3. Locate the fuel line between the fuel valve and back of control panel. Disconnect the fuel line from the fuel valve.  
**NOTE:** A small amount of fuel may leak from the fuel line during removal.
4. Place a funnel below the fuel valve opening, and direct the other end of the funnel over the prepared container. Turn the fuel valve to ON to start draining the fuel from the fuel valve opening.
5. Once the fuel is drained, shut OFF the fuel valve.
6. Start and run the engine until the fuel runs out.
7. Drain the carburetor.
8. Store the emptied gasoline in a suitable place. **DO NOT** store flammable materials near the gasoline. Do not store fuel for more than 3 months.

**CAUTION:** Store the emptied gasoline in a suitable place. Never store fuel for more than 2 months.

**NOTE:** You can also drain the fuel tank through the carburetor. Follow the procedures in “Draining the Carburetor”, and turn the fuel valve ON. It may take a while for the fuel tank to drain, depending on the amount of fuel in the tank.

## TRANSPORTATION & STORAGE

### TRANSPORTING THE GENERATOR

To prevent fuel spillage when transporting, be sure to perform the following to your generator:

1. Tighten the fuel cap and make sure the fuel valve is turned OFF.
2. Make sure the engine switch is in the OFF position.
3. Drain the fuel tank if possible (see “Draining the Fuel Tank”).
4. Keep the generator upright. Never place the generator on its side or upside down - doing so could damage the internal components of the generator and make it difficult to start.

**⚠ WARNING!** Avoid direct sunlight inside a vehicle. If the generator is left in an enclosed vehicle for many hours, the high temperature could cause the fuel to vaporize and result in a possible explosion.

### STORING THE GENERATOR

Shut off the generator and allow the unit to cool to room temperature before storing it. Never place any type of storage cover on the generator while it is still hot. Do not obstruct any ventilation openings.

Follow the procedures below for properly storing your generator. We highly recommend running your generator once a month for 20 to 30 minutes. Plug in a small load in to ensure there is proper power output.

#### For Short Periods (30 to 60 Days):

- Drain the carburetor.
- Disconnect the negative terminal from the battery.
- **Add fuel stabilizer:**

Follow the suggested portions and instructions of your preferred stabilizer. Run the engine for 15 to 20 minutes, allowing the fuel stabilizer to mix with the gasoline and circulate through the carburetor, and then top off with fuel. Filling the fuel tank full reduces the amount of air in the tank and helps fight deterioration of fuel.

#### For Extended Periods (Over 60 Days):

- Drain the fuel tank and carburetor (see “DRAINING THE FUEL TANK”). NEVER store generator with fuel in the tank for more than two months.
- Change the engine oil (see “CHANGING OIL”).

**⚠ WARNING!** Store the generator upright in a cool and dry location, away from sources of heat, open flames, sparks or pilot lights.

### PRODUCT DISPOSAL

Do not dispose of used generator or parts with your household waste. This product contains electrical or electronic components that should be recycled. Please take this product to your local recycling facility for responsible disposal to minimize its environmental impact.

Do not dispose of used oil or fuel in the trash or down a drain. Please contact your local recycling center or auto garage to arrange proper oil/fuel disposal.

# TROUBLESHOOTING GUIDE

**⚠ WARNING!** Stop using the generator immediately if any of the following problems occur or risk serious personal injury. If you have any questions, please contact customer service at **1-847-429-9263** (M-F 8-5 CST), or email **techsupport@wenproducts.com**.

PROBLEM	POSSIBLE CAUSE	SOLUTION
<b>Engine will not start.</b>	Engine switch is set to OFF.	Set engine switch to ON.
	Fuel valve is turned to OFF.	Turn fuel valve to ON.
	Oil is low.	Add or replace oil.
	Engine is out of fuel.	Add fuel.
	Engine is filled with contaminated or old fuel.	Drain fuel in the tank. Fill with fresh fuel.
	Spark plug is dirty or broken.	Clean or replace the spark plug.
	Carburetor is air locked.	Shut off the fuel valve. Remove the bolt from the bottom of the carburetor. Take off the carburetor bowl to allow it to reset. Replace carburetor bowl and reinstall the bolt.
	Propane tank is OFF.	Turn tank ON.
	Regulator is stuck.	Turn OFF propane tank. Disconnect hose from onboard regulator. Spray a small amount of penetrating oil into regular inlet, then gently insert a pin into inlet to break valve free.
	CO levels too high.	Refer to "CO Sensor Information".
	CO sensor disconnected, removed, or faulty.	Connect or install the CO sensor. If an error is shown, contact WEN customer service for assistance. Also refer to "CO Sensor Information".
<b>Engine runs but there is no electrical output whatsoever.</b>	Circuit breaker has been tripped due to overload.	Turn off and unplug electrical device(s). Wait 5 minutes, then press the circuit breaker to reset. Check the total wattage of the devices and reduce the load if it exceeds the capacity of the generator. Then plug the loads back in one by one.
	Bad connecting cords/wires.	Check the power cords and extension cords. Do not use if any cord is damaged. Replace damaged cords immediately.
	Bad electrical device connected to the generator.	Try connecting a different device.
	Voltage regulator is bad	Check voltage regulator with a multimeter, replace if necessary.
	Carbon brushes worn or need adjustment	Check carbon brushes, adjust so that both brushes extrude the same length, or replace if worn.
<b>Generator runs but does not support all electrical devices connected.</b>	Generator is overloaded.	Turn off and unplug all electrical devices. Wait 5 minutes, then press the circuit breaker to reset. Reduce load as necessary, then plug devices back in one by one.
	Short circuit in one of the devices.	Try disconnecting any faulty or short-circuited electrical loads.
	Air filter is dirty.	Clean or replace the air filter element.
<b>Engine is "hunting" during operation (engine RPM is fluctuating).</b>	<ol style="list-style-type: none"> <li>The fuel isn't running through the fuel valve.</li> <li>The air filter is clogged.</li> <li>The muffler or spark arrestor is blocked</li> <li>There is gunk in the carburetor preventing a consistent fuel/air mixture.</li> </ol>	Turn off the generator and wait for it to cool down. <b>Perform the following steps:</b> <ol style="list-style-type: none"> <li>Check if the fuel is properly and consistently going through the fuel valve</li> <li>Check for any blockage in the air filter. Check and clean the air filter as necessary.</li> <li>Check if the spark arrestor is blocked. Clean with metal brush as necessary.</li> <li>Use "gunk remover" spray on the carburetor jets.</li> </ol>

# WIRING DIAGRAM

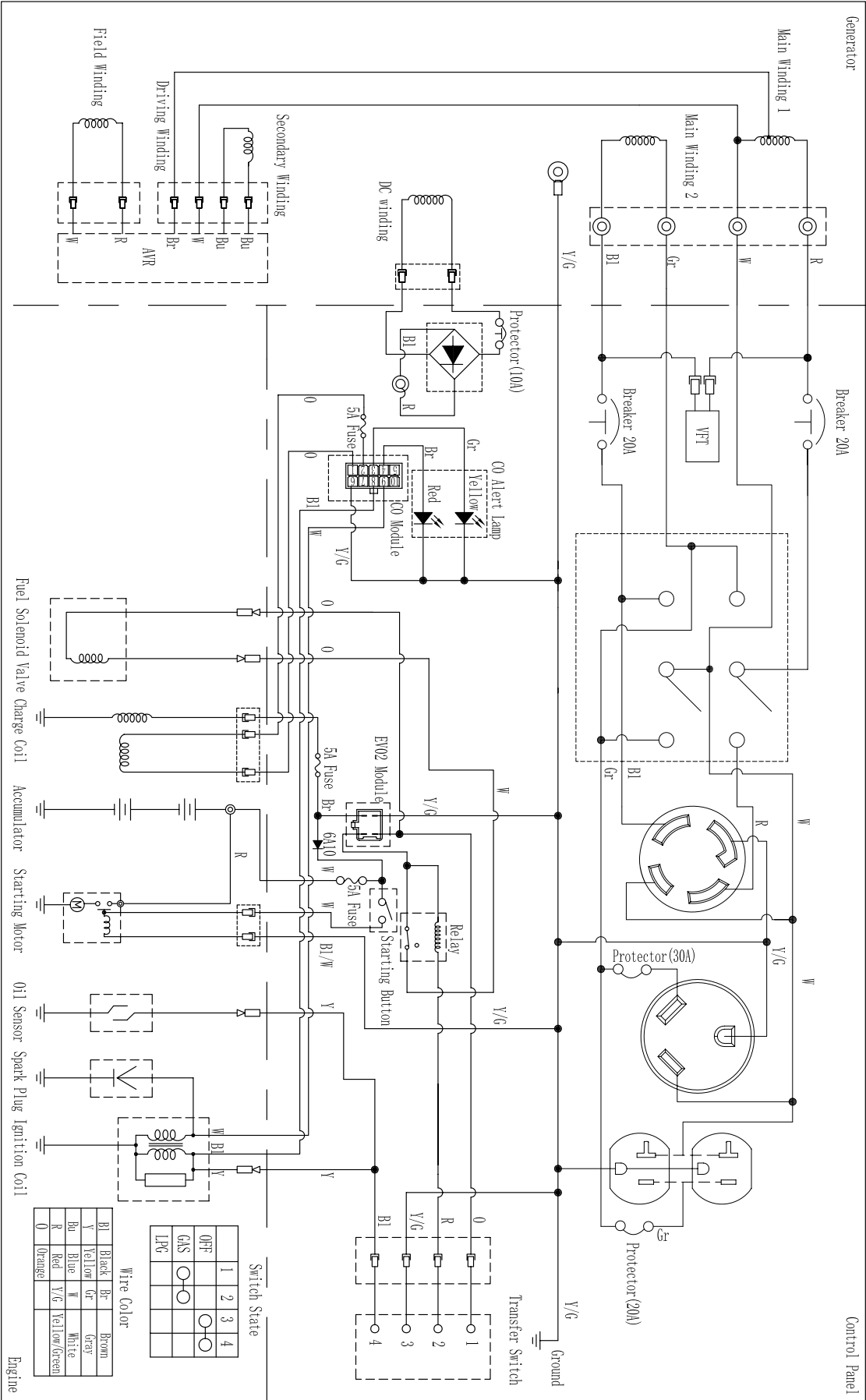



# EXPLODED VIEW & PARTS LIST

## GENERATOR

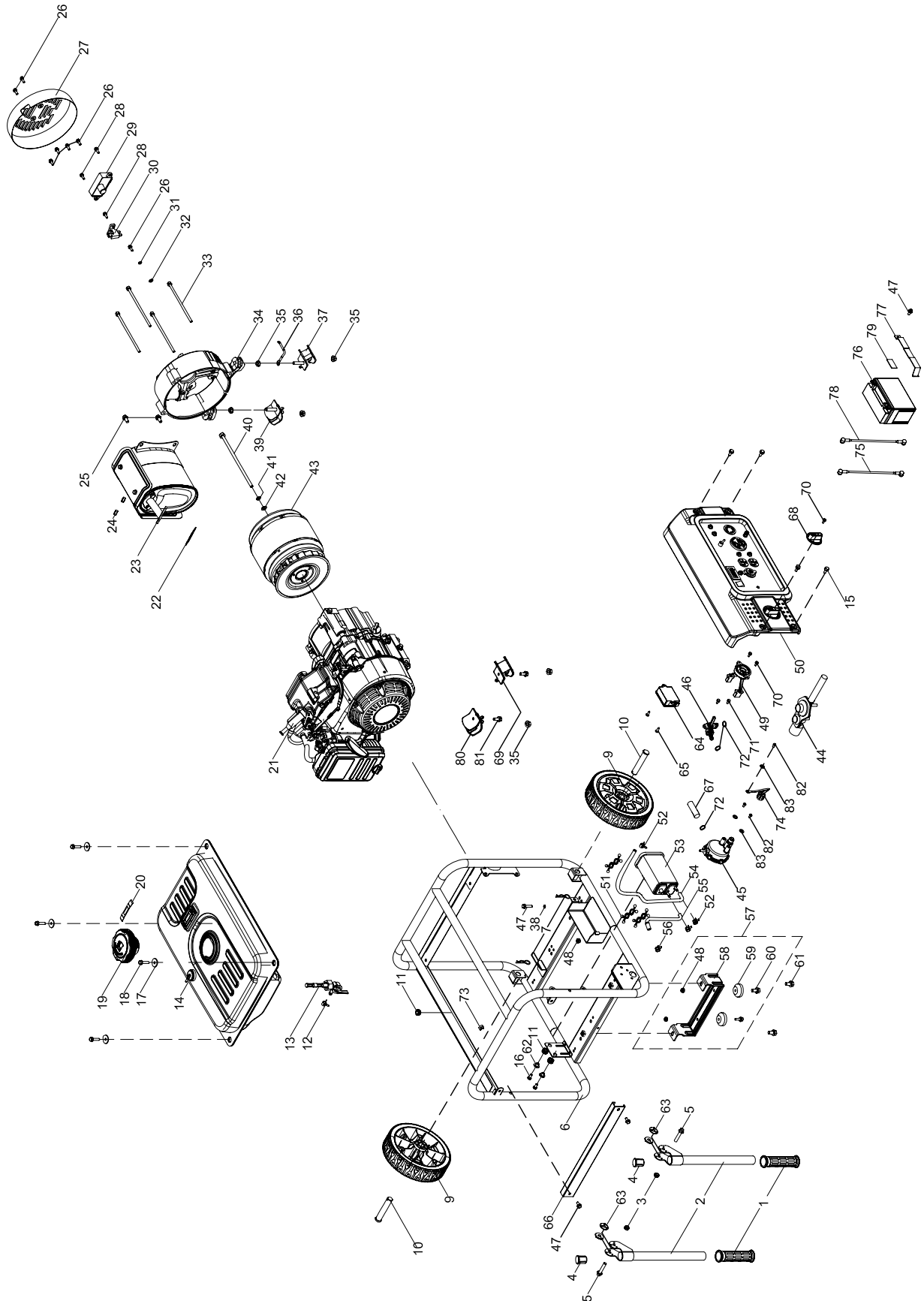

## EXPLODED VIEW & PARTS LIST

### GENERATOR

No.	Part No.	Description	Qty.	No.	Part No.	Description	Qty.
1	56500-001	Handrail Jacket	2	34	56500-035	Rear Bracket	1
2	DF623X-002	Push Handle	2	35	56500-036	Nut, M8	6
3	GN6000-003	Nut M8	2	36	56500-037	Earth Wire	1
4	56500-001	Handrail Plug	2	37	GN6000-038	Damping Pad	1
5	GN6000-005	Bolt, M8x40	2	38	56500-1038	Washer, $\phi 6$	1
6	DF623X-006	Frame Assembly	1	39	GN6000-039	Damping Pad	1
7	56500-007	Circlip	2	40	56500-040	Bolt, M10x1.25x225	1
9	56500-008	Tire	2	41	56500-041	Washer, $\phi 10$	1
10	DF623X-010	Wheel Shaft	2	42	56500-042	Washer, $\phi 10$	1
11	56500-010	Damping Pad	3	43	56500-043	Alternator	1
12	56500-011	Clamp	1	44	DF623X-044	Gas Pressure Reducing Valve	1
13	DF623X-013	Fuel Switch	1	45	DF623X-045	Gas Pressure Reducing Valve	1
14	DF623X-014	Fuel Tank	1	46	DF623X-046	Valve	1
15	DF623X-015	Bolt, M6x14	4	47	56500-1047	Bolt, M6x12	4
16	DF623X-016	Bolt, M6x16	2	48	56500-044	Nut, M6	3
17	56500-016	Washer, $\phi 6.5 \times 2 \times \phi 25$	4	49	DF623X-049	Switch	1
18	56500-017	Bolt, M6x25	4	50	DF623X-050	Control Panel	1
19	56500-018	Fuel Cap	1	51	56500-047	Clamp	3
20	56500-019	Oily Sense Clip	1	52	56500-052	Clamp	3
21	DF623X-021	Engine	1	53	56500-049	Carbon Canister	1
22	56500-023	Gasket, Muffler	1	54	DF623X-054	Tube, Carbon Canister	1
23	56500-024	Muffler	1	55	56500-051	Tube, Carbon Canister	1
24	56500-025	Nut, M8	2	56	DF623X-056	Clamp	1
25	56500-026	Bolt, M8x16	2	57	56500-057	Support Base	1
26	56500-027	Bolt, M5x14	7	58	56500-058	Support Base	1
27	GN9500-037	End Cover	1	59	56500-059	Damping Pad	2
28	56500-029	Bolt, M5x18	3	60	56500-054	Bolt, M6x18	2
29	56500-030	Voltage Regulator	1	61	56500-060	Bolt, M8x16	2
30	56500-031	Brush	1	62	56500-055	Bush	2
31	56500-032	Washer, $\phi 5$	1	63	DF623X-063	Washer	4
32	56500-033	Washer, $\phi 5$	1				
33	56500-034	Bolt, M6x150	4				

## **EXPLODED VIEW & PARTS LIST**

### **GENERATOR**

<b>No.</b>	<b>Part No.</b>	<b>Description</b>	<b>Qty.</b>	<b>No.</b>	<b>Part No.</b>	<b>Description</b>	<b>Qty.</b>
64	GN9500X-071	CO Alarm Controler	1	74	DF623X-074	Dust cover	1
65	DF623X-065	Self-tappling Screw, ST4.2x16	2	75	DF623X-075	Cathode Wire	1
66	DF623X-066	Across Bar	1	76	DF623X-076	Battery	1
67	DF623X-067	Natural Gas Pipe	1	77	GN9500-058	Binder Plate	1
68	DF623X-068	Oil Switch Knob	1	78	DF623X-078	Anode Wire	1
69	GN6000-045	Damping Pad	1	79	GN9500X-070	Rubber Mat	1
70	DF623X-070	Bolt, M4x12	3	80	GN6000-044	Damping Pad	1
71	DF623X-071	Bolt, M5x12	2	81	56500-1046	Bolt, M8x16	2
72	DF623X-072	Clamp	3	82	DF623X-082	Screw, M6x10	3
73	DF623X-073	Clip	1	83	GN9500-062	Gasket, Drain Bolt	3

# EXPLODED VIEW & PARTS LIST

## ENGINE

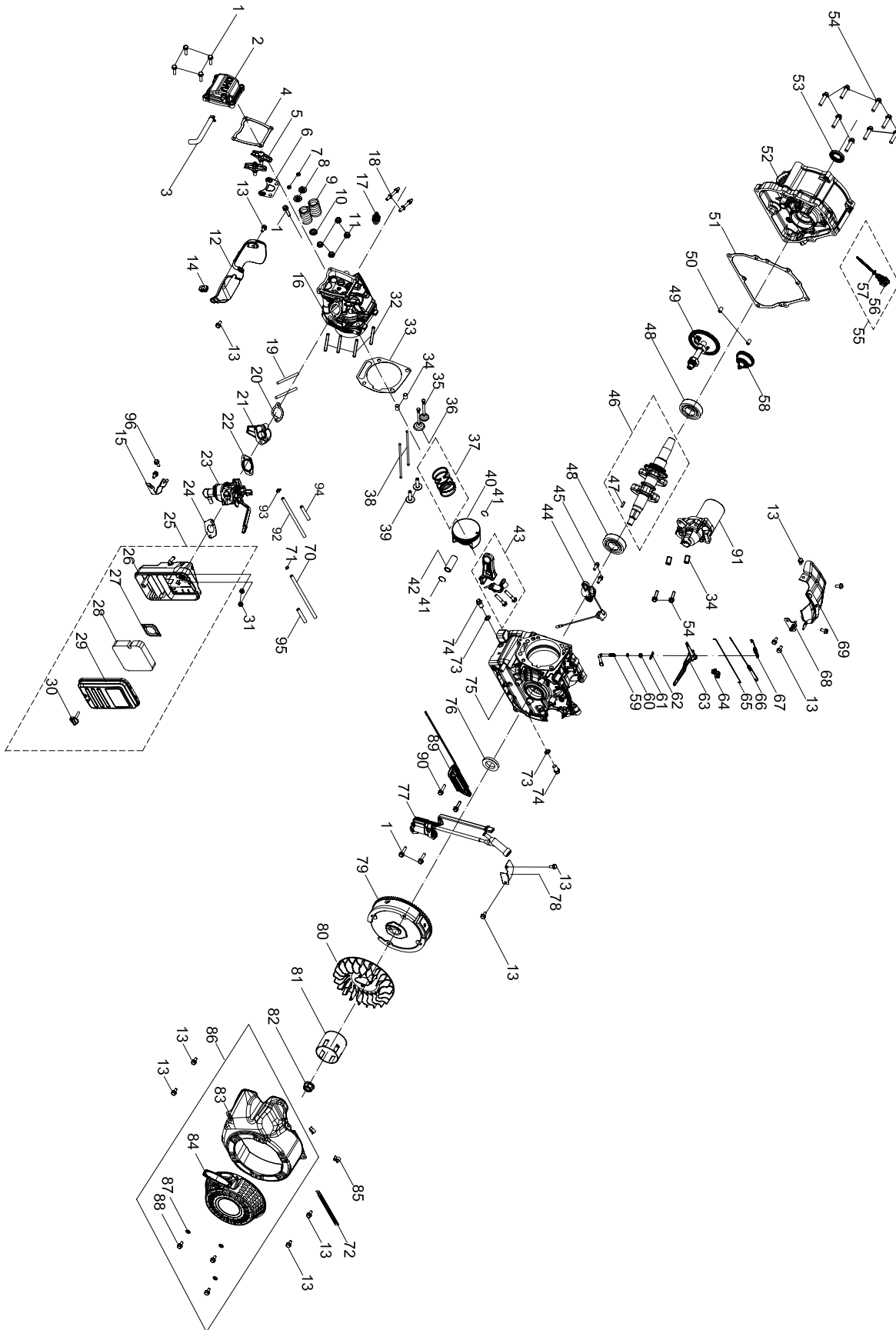

## EXPLODED VIEW & PARTS LIST

### ENGINE

No.	Part No.	Description	Qty.
1	56500-017	Bolt, M6x25	7
2	56500-1195ASM	Valve Cover	1
3	DF623X-083	Breather Hose	1
4	56500-110	Gasket, Valve Cover	1
5	56500-111	Rocker Arm Assembly	2
6	56500-112	Rocker Arm Base	1
7	56500-113	Valve Locker	4
8	56500-114	Valve Spring Seat	2
9	56500-115	Valve Spring	2
10	56500-116	Intake Valve Seal	1
11	56500-117	Nut, M8	4
12	56500-119	Shroud	1
13	56500-022	Bolt, M6x12	13
14	56500-1120	Gasket	1
15	56500-1193	Air Filter Bracket	1
16	DF623X-084	Cylinder Head	1
17	56500-123	Spark Plug	1
18	56500-124	Stud	2
19	56500-125	Stud, M6x95	2
20	56500-126	Gasket, Carburetor Insulator	1
21	56500-127	Insulator	1
22	56500-128	Gasket, Carburetor	1
23	DF623X-085	Carburetor	1
24	56500-130	Gasket Carburetor	1
25	DF623X-086	Air Filter Assembly	1
26	DF623X-087	Air Filter Base Assembly	1
27	56500-133	Air Filter Baffle	1
28	56500-134	Air Filter Element	1
29	DF623X-088	Air Filter Cover	1
30	56500-136	Bolt	1

No.	Part No.	Description	Qty.
31	56500-137	Nut, M6	2
32	56500-138	Stud, M8x60	4
33	56500-139	Gasket, Cylinder Head	1
34	56500-140	Pin, $\phi$ 10x14	4
35	56500-142	Exhaust Valve	1
36	56500-141	Intake Valve	1
37	56500-143	Piston Ring Set	1
38	56500-144	Push Rod	2
39	56500-145	Tappet	2
40	56500-146	Piston	1
41	56500-147	Circlip	2
42	56500-148	Piston Pin	1
43	56500-149	Connecting Rod Assembly	1
44	56500-150	Oil Sensor	1
45	56500-151	Bolt, M6x18	2
46	56500-152	Crankshaft	1
47	56500-153	Woodruff Key	1
48	56500-1151	Bearing, TM6206	2
49	56500-155	Camshaft	1
50	56500-156	Pin, $\phi$ 8x14	2
51	56500-157	Gasket, Crankcase	1
52	56500-158	Crankcase Cover	1
53	56500-159	Oil Seal, $\phi$ 25x $\phi$ 41.25x6	1
54	56500-160	Bolt, M8x35	10
55	56500-161	Dipstick	1
56	56500-163	Dipstick	1
57	56500-162	O-Ring, $\phi$ 15.8x2.5	1
58	56500-164	Governor Gear	1
59	56500-165	Governor Gear Shaft	1
60	56500-166	O-Ring, $\phi$ 5.2x1.9	1

## EXPLODED VIEW & PARTS LIST

### ENGINE

No.	Part No.	Description	Qty.
61	56500-167	Oil Seal, φ6xφ11x4	1
62	56500-168	Cotter Pin	1
63	56500-169	Governor Lever	1
64	56500-170	Choke Linkage Lock Clamp	1
65	56500-171	Throttle Linkage	1
66	56500-172	Idle Spring	1
67	56500-173	Governor Spring	1
68	56500-174	Throttle Adjust Bracket Assembly	1
69	56500-175	Governor Gear Bracket Assembly	1
70	DF623X-089	Fuel Hose, φ4xφ8x190	1
71	56500-011	Clamp	1
72	DF623X-090	Clip	1
73	56500-180	Washer, φ10x1.5xφ16	2
74	56500-179	Earth Bolt	2
75	DF623X-091	Crankcase	1
76	56500-182	Oil Seal, φ30xφ46x8	1

No.	Part No.	Description	Qty.
77	DF623X-092	Ignition Module	1
78	56500-184	Wire Board	1
79	DF623X-093	Flywheel	1
80	56500-186	Cooling Fan	1
81	56500-187	Starter Cup	1
82	56500-188	Nut, M14x1.5	1
83	DF623X-094	Blower Housing	1
84	56500-191	Recoil Starter	1
85	56500-1194	Clip	2
86	DF623X-095	Recoil Starter	1
87	56500-192	Washer, φ6	3
88	56500-193	Bolt, M6x10	3
89	DF623X-096	Charging Coil	1
90	DF623X-097	Bolt, M6x28	2
91	DF623X-098	Electric Starter	1
92	DF623X-099	Natural Gas Pipe	1
93	DF623X-100	Clamp, Fuel Hose	1
94	DF623X-101	Fiberglass Tube, φ20x150	1
95	DF623X-102	Fiberglass Tube, φ10x140	1
96	56202i-013	Bolt, M6x12	2

# EXPLODED VIEW & PARTS LIST

## CONTROL PANEL

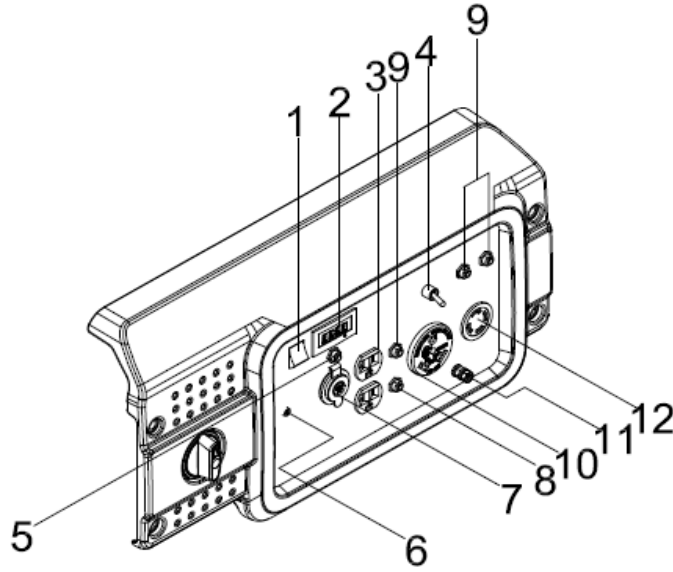

No.	Part No.	Description	Qty.
1	DF623X-301	Engine Switch	1
2	GN9500-313	Multi-Meter	1
3	56500-205	AC 120V NEMA 5-20R Duplex Outlet	1
4	56500-207	Voltage Selector Switch	1
5	GN9500-301	DC Breaker, 10A	1
6	GN9500X-302	CO Sensor LED	1

No.	Part No.	Description	Qty.
7	56500-204	DC 12V Outlet	1
8	56500-1205	AC Breaker, 30A	1
9	56500-208	AC Breaker, 20A	3
10	56500-206	AC 120V NEMA TT-30R RV Outlet	1
11	GN9500-312	Grounding Nut	1
12	56500-209	AC 120V/240V NEMA L14-30R Outlet	1

# **WARRANTY STATEMENT**

WEN Products is committed to building tools that are dependable for years. Our warranties are consistent with this commitment and our dedication to quality.

## **LIMITED WARRANTY OF WEN PRODUCTS FOR HOME USE**

GREAT LAKES TECHNOLOGIES, LLC (“Seller”) warrants to the original purchaser only, that all WEN consumer power tools will be free from defects in material or workmanship during personal use for a period of two (2) years from date of purchase or 500 hours of use; whichever comes first. Ninety days for all WEN products if the tool is used for professional or commercial use. Purchaser has 30 days from the date of purchase to report missing or damaged parts.

**SELLER’S SOLE OBLIGATION AND YOUR EXCLUSIVE REMEDY** under this Limited Warranty and, to the extent permitted by law, any warranty or condition implied by law, shall be the replacement of parts, without charge, which are defective in material or workmanship and which have not been subjected to misuse, alteration, careless handling, misrepair, abuse, neglect, normal wear and tear, improper maintenance, improper storage, incorrect lubricants/fuels, or other conditions adversely affecting the Product or the component of the Product, whether by accident or intentionally, by persons other than Seller. To make a claim under this Limited Warranty, you must make sure to keep a copy of your proof of purchase that clearly defines the Date of Purchase (month and year) and the Place of Purchase. Place of Purchase must be a direct vendor of Great Lakes Technologies, LLC. Purchasing through third party vendors, including but not limited to garage sales, pawn shops, resale shops, or any other secondhand merchant, voids the warranty included with this product. Contact [techsupport@wenproducts.com](mailto:techsupport@wenproducts.com) or 1-847-429-9263 with the following information to make arrangements: your shipping address, phone number, serial number, required part numbers, and proof of purchase. Damaged or defective parts and products may need to be sent to WEN before the replacements can be shipped out.

Upon the confirmation of a WEN representative, your product may qualify for repairs and service work. When returning a product for warranty service, the shipping charges must be prepaid by the purchaser. The product must be shipped in its original container (or an equivalent), properly packed to withstand the hazards of shipment. The product must be fully insured with a copy of the proof of purchase enclosed. There must also be a description of the problem in order to help our repairs department diagnose and fix the issue. Repairs will be made and the product will be returned and shipped back to the purchaser at no charge for addresses within the contiguous United States.

**THIS LIMITED WARRANTY DOES NOT APPLY TO ITEMS THAT WEAR OUT FROM REGULAR USAGE OVER TIME, INCLUDING FILTERS, SPARK PLUGS, VOLTAGE REGULATORS, BRUSHES, GASKETS, O-RINGS, WHEEL KITS, BATTERIES, RECOIL STARTERS, HIGH PRESSURE HOSES, SPRAY GUNS, ETC. ANY IMPLIED WARRANTIES SHALL BE LIMITED IN DURATION TO TWO (2) YEARS FROM DATE OF PURCHASE. SOME STATES IN THE U.S. AND SOME CANADIAN PROVINCES DO NOT ALLOW LIMITATIONS ON HOW LONG AN IMPLIED WARRANTY LASTS, SO THE ABOVE LIMITATION MAY NOT APPLY TO YOU.**

**IN NO EVENT SHALL SELLER BE LIABLE FOR ANY INCIDENTAL OR CONSEQUENTIAL DAMAGES (INCLUDING BUT NOT LIMITED TO LIABILITY FOR LOSS OF PROFITS) ARISING FROM THE SALE OR USE OF THIS PRODUCT. SOME STATES IN THE U.S. AND SOME CANADIAN PROVINCES DO NOT ALLOW THE EXCLUSION OR LIMITATION OF INCIDENTAL OR CONSEQUENTIAL DAMAGES, SO THE ABOVE LIMITATION OR EXCLUSION MAY NOT APPLY TO YOU.**

**THIS LIMITED WARRANTY GIVES YOU SPECIFIC LEGAL RIGHTS, AND YOU MAY ALSO HAVE OTHER RIGHTS WHICH VARY FROM STATE TO STATE IN THE U.S., PROVINCE TO PROVINCE IN CANADA AND FROM COUNTRY TO COUNTRY.**

**THIS LIMITED WARRANTY APPLIES ONLY TO ITEMS SOLD WITHIN THE UNITED STATES OF AMERICA, CANADA AND THE COMMONWEALTH OF PUERTO RICO. FOR WARRANTY COVERAGE WITHIN OTHER COUNTRIES, CONTACT THE WEN CUSTOMER SUPPORT LINE. FOR WARRANTY PARTS OR PRODUCTS REPAIRED UNDER WARRANTY SHIPPING TO ADDRESSES OUTSIDE OF THE CONTIGUOUS UNITED STATES, ADDITIONAL SHIPPING CHARGES MAY APPLY.**