

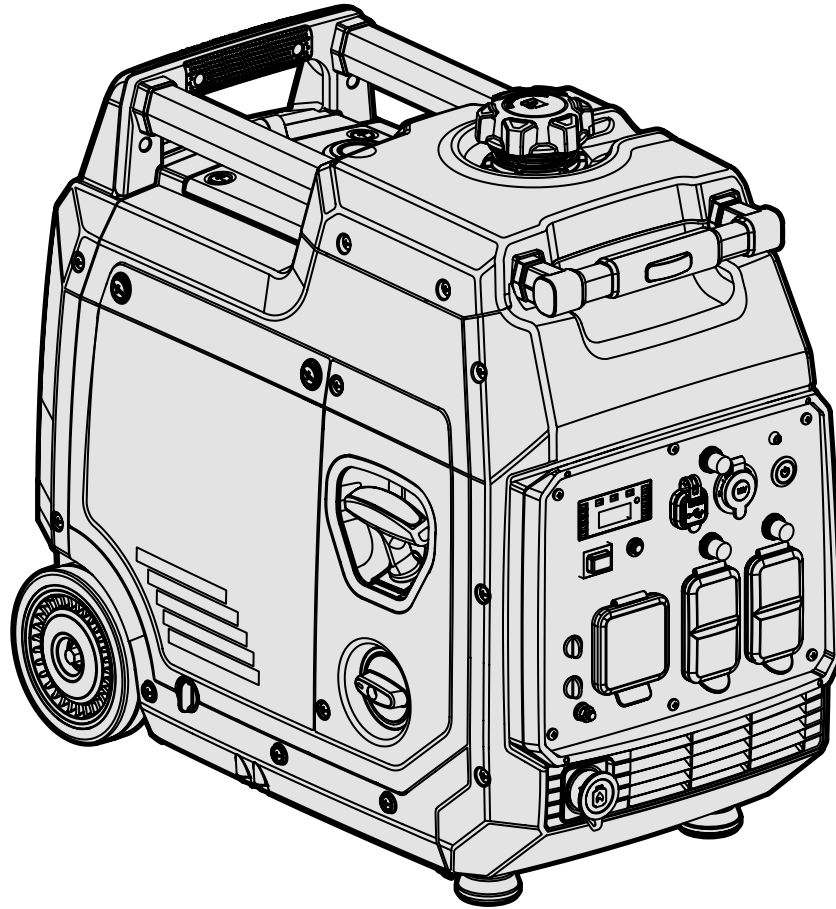

MODEL DF480iX

4800-WATT DUAL FUEL INVERTER GENERATOR

Instruction Manual



NEED HELP? CONTACT US!

Have product questions? Need technical support? Please feel free to contact us:



1-847-429-9263 (M-F 8AM-5PM CST)



TECHSUPPORT@WENPRODUCTS.COM

IMPORTANT: Your new tool has been engineered and manufactured to WEN's highest standards for dependability, ease of operation, and operator safety. When properly cared for, this product will supply you years of rugged, trouble-free performance. Pay close attention to the rules for safe operation, warnings, and cautions. If you use your tool properly and for its intended purpose, you will enjoy years of safe, reliable service.

For replacement parts and the most up-to-date instruction manuals, visit ***WENPRODUCTS.COM***

CONTENTS

WELCOME	3
Specifications.....	3
Introduction	4
SAFETY	5
Safety Information	5
Generator Safety Warnings	6
BEFORE OPERATING	9
Unpacking & Packing List.....	9
Know Your Inverter Generator.....	10
Preparation	12
OPERATION & MAINTENANCE	18
Starting Your Generator	18
Using Your Generator.....	22
Stopping Your Generator	27
Maintenance.....	28
Transportation & Storage.....	33
Troubleshooting Guide.....	34
Wire Diagram.....	35
Exploded View & Parts List.....	36
Warranty Statement	42

To purchase accessories for your tool, visit ***WENPRODUCTS.COM***

Magnetic Oil Dipstick (Model No. 55201)

Weatherproof Generator Cover (Model No. 56310iC)

High-Altitude Kit (Part No. DF480iX-HA39)

WEN Parallel Connection Kit

SPECIFICATIONS

GENERATOR

Model Number	DF480iX
Surge (Starting) Wattage	Gasoline: 4800W
	LPG: 4320W
Rated (Running) Wattage	Gasoline: 4000W
	LPG: 3600W
Rated Voltage	AC: 120V; DC: 12V / 5V
Rated Amperage	AC 33.3A; DC 8.3A (12V), 2.1A / 1A (USB)
Phase	Single
Frequency	60 Hz
Product Weight	78.5 Pounds
Product Dimensions	23.8 in. x 12.6 in. x 22.1 in.

ENGINE

Engine Type	4 Stroke, OHV, Single Cylinder with Forced Air Cooling System
Engine Displacement	224cc
Engine Speed	3600 RPM
Fuel Tank Capacity	1.9 gallons (7.20 L)
Oil Capacity	20.3 fl. oz. (0.60 L)
Half-Load Run Time	Gasoline: 7 Hours
	LPG: 20 Hours on a 20lb-Tank
Spark Plug Type	LG F6RTC (NGK BPR6ES)
Spark Plug Gap	0.024 - 0.031 in. (0.6 - 0.8 mm)
Spark Plug Torque	11 - 14.5 ft-lbs (15 - 20 Nm)
Battery	12V, 1.6Ah, Li-Ion

INTRODUCTION

Thanks for purchasing the WEN 4800-Watt Dual Fuel Inverter Generator. Refer to the illustration below for the location of the serial number on the specifications label. Record the generator information in the spaces provided below. If assistance for information or service is required, please contact customer service by calling **1-847-429-9263**, M-F 8-5 CST; you will be asked to provide the following generator information when calling.

Generator Model Number: DF480iX

Date of Purchase: _____

Purchased From: _____

Serial Number: _____

Serial Number





**4800-WATT DUAL FUEL
PORTABLE INVERTER GENERATOR**

MODEL DF480iX

RATED WATTAGE	GAS: 4000W; LPG: 3600W	RATED FREQUENCY	60 Hz
SURGE WATTAGE	GAS: 4800W; LPG: 4320W	RATED VOLTAGE	AC: 120V DC: 12V
SERIAL NO.		SPARK PLUG TYPE	F6RTC
ENGINE SERIAL NO.		SPARK PLUG GAP	0.6mm - 0.8mm

1-847-429-9263 WENPRODUCTS.COM

Great Lakes Technologies LLC • 1101 Wesemann Drive • West Dundee, IL 60118

**GÉNÉRATEUR
ONDULEUR**

TYPE 1
MADE IN VIETNAM

SERVICE RECORD

Record the service dates of your generator in the chart below. Please perform maintenance checks and operations according to the “Maintenance” section of the manual.

Service Record	Date	Date	Date	Date	Date	Date
Change Oil						
Change Spark Plug						
Clean Fuel Tank						
Clean Air Filter						
Clean Spark Arrestor						

TO MAXIMIZE THE LIFESPAN OF YOUR GENERATOR: We recommend running your generator at least once a month for 20 to 30 minutes. Start the generator according to the instructions and plug a small load in to make sure the outlet is producing electricity.

SAFETY INFORMATION

 **WARNING!** Before operating the generator, make sure to read all safety warnings and all instructions. Failure to follow the warnings and instructions may result in electric shock, fire or serious injury.

SAFETY INTRODUCTION

Safety is a combination of common sense, staying alert, and knowing how your tool works. This manual contains important information regarding the generator's potential safety concerns, as well as preparation, operation, and maintenance instructions. Before operating this generator, be sure to read and observe all warnings and instructions both on the generator labels and in this instruction manual. Failure to follow all instructions listed below may result in personal injury.

NOTE: The following safety information is not meant to cover all possible conditions and situations that may occur. WEN reserves the right to change this product and specifications at any time without prior notice.

At WEN, we are continuously improving our products. If you find that your tool does not exactly match this manual, please visit wenproducts.com for the most up-to-date manual or contact customer service at **1-847-429-9263**, M-F 8-5 CST.

Keep this manual available to all users during the entire life of the tool and review it frequently to maximize safety for both yourself and others.

SAVE THESE SAFETY INSTRUCTIONS.

SAFETY SYMBOLS

The purpose of following safety symbols is to attract your attention to possible dangers. The safety symbols, and their explanations, deserve your careful attention and understanding. The safety warnings do not by themselves eliminate any danger. The instructions or warnings they give are not substitutes for proper accident prevention measures.

 **DANGER:** indicates a hazard, which, if not avoided, will result in death or serious injury.

 **WARNING:** indicates a hazard, which, if not avoided, could result in death or serious injury.

 **CAUTION:** indicates a hazard, which, if not avoided, might result in minor or moderate injury.

CAUTION! when used without the alert symbol, indicates a situation that could result in damage to the machine.

NOTICE REGARDING EMISSIONS

Engines that are certified to comply with U.S. EPA emission regulations for SORE (Small Off Road Equipment), are certified to operate on regular unleaded gasoline, and may include the following emission control systems: (EM) Engine Modifications and (TWC) Three-Way Catalyst (if so equipped).

QUESTIONS? PROBLEMS?

In order to answer questions and solve problems in the most efficient and speedy manner, contact customer service at **1-847-429-9263**, M-F 8-5 CST or email techsupport@wenproducts.com.

GENERATOR SAFETY WARNINGS

DANGER! CARBON MONOXIDE

Using a generator indoors **CAN KILL YOU IN MINUTES**. Generator exhaust contains carbon monoxide (CO). This is a poison gas you cannot see or smell. If you can smell the generator exhaust, you are breathing CO. But even if you cannot smell the exhaust, you could be breathing CO.





NEVER use a generator inside homes, garages, crawl spaces, or other partially enclosed areas. Deadly levels of carbon monoxide can build up in these areas. Using a fan or opening windows and doors does **NOT** supply enough fresh air. **ONLY** use a generator outside and far away from windows, doors, and vents. These openings can pull in generator exhaust.

Even if you use a generator correctly, CO may leak into the home. **ALWAYS** use a battery-powered or battery-backup CO alarm in the home. If you start to feel sick, dizzy, or weak after the generator has been running, move to fresh air **RIGHT AWAY**. See a doctor. You may have carbon monoxide poisoning.

 **WARNING! RISK OF EXPLOSION. HIGHLY FLAMMABLE:** This generator may emit highly flammable and explosive gasoline vapors, which can cause severe burns or even death, if ignited. A nearby open flame can lead to explosion even if not directly in contact with gasoline.

- Do not operate near open flame, heat, or any other ignition source. Do not smoke near the generator.
- Always operate on a firm, level surface.
- Always turn generator off before refueling. Allow generator to cool for at least 2 minutes before removing fuel cap. Loosen cap slowly to relieve pressure in tank.
- Do not overfill fuel tank. Gasoline may expand during operation. Do not fill to the top of the tank. Allow for expansion. Always check for spilled fuel before operating.
- If fuel spills, move the generator at least 30 feet away from the spill and wipe clean any spilled fuel before starting the engine.
- Empty fuel tank before storing or transporting the generator.

 **WARNING!** If this generator is used as a supply for a building's wiring system, the generator must be installed by a qualified electrician and connected to a transfer switch as a separately derived system in accordance with all applicable laws and electrical codes and the National Electrical Code, NFPA 70. The generator shall be connected to a transfer switch that switches all conductors excluding the equipment grounding conductor. The frame of the generator shall be connected to an approved grounding electrode.

 **WARNING!** This product can expose you to chemicals including carbon monoxide and engine exhaust, which are known to the State of California to cause cancer and birth defects or other reproductive harm. For more information, go to www.P65Warnings.ca.gov.

GENERATOR SAFETY WARNINGS

 **WARNING!** Do not let comfort or familiarity with the product replace strict adherence to product safety rules. Failure to follow the safety instructions may result in serious personal injury.

OPERATING ENVIRONMENT

1. **Using a generator indoors can kill you in minutes.** Only use a generator outside and far away from windows, doors and vents.

2. **Do not smoke near the generator.**

3. **Do not operate near open flame, heat, or flammable materials.** This generator may emit highly flammable and explosive gasoline vapors, which can cause severe burns or even death if ignited. A nearby open flame can lead to an explosion even if it isn't directly in contact with gasoline.

4. **Do not expose the generator to rainy or wet conditions; doing so significantly increases the risk of electrical shock.** Never handle the generator, electronic devices, or any cord while standing in water, while barefoot, or when hands or feet are wet.

5. **Always operate the generator on a dry, firm, level surface.**

6. **The generator should have at least 5 feet of clearance from buildings or other equipment during operation.**

7. **Do not allow children or non-qualified persons to operate the generator.**

GENERATOR PREPARATION

1. **Always ground the generator before using it to maximize safety** (see "Ground the Generator" section).

2. **Do not overfill fuel tank, as gasoline may expand during operation.** Do not fill to the very top of the tank. Leave room for gasoline expansion. Always check for spilled fuel before operating.

3. **If any part of the generator, electrical device or power cord is broken, damaged, or defective, make sure it is repaired or replaced before operation.** Service should only be performed by a qualified technician. Do not use receptacles or cords that show signs of damage, such as broken or cracked insulation.

4. **Use a ground fault circuit interrupter (GFCI) in highly conductive areas such as metal decking or steel work.** Extension cords with in-line GFCIs are recommended for these operations to maximize safety.

5. **If connecting the generator to a building's electrical system for standby power, you MUST consult a qualified electrician and install a transfer switch.** Such connections must comply with local electrical laws and codes. Failure to comply can create a back-feed, which may result in serious injury or death to utility workers.

6. **Never modify the generator in any way.** Modifying or using the machine for any other purpose for which it is not designed may result in serious injuries, machine damage and voiding of the warranty.

GENERATOR OPERATION

1. **Only use the generator for its intended purposes.** Modifying or using the generator for operations for which it was not designed may cause hazards and personal injury.

2. **Do not touch bare wires or receptacles (outlets).**

3. **Do not exceed the wattage capacity of the generator by plugging in more electrical devices than the unit can handle.** This could damage the generator and/or connected electrical devices. Check the operating voltage and frequency requirements of all electrical devices prior to plugging them into the generator.

Generator safety warnings continue on the next page.

GENERATOR SAFETY WARNINGS

 **WARNING!** Do not let comfort or familiarity with the product replace strict adherence to product safety rules. Failure to follow the safety instructions may result in serious personal injury.

TO MAXIMIZE THE LIFESPAN OF YOUR GENERATOR: We recommend running your generator at least once a month for 20 to 30 minutes. Start the generator according to the instructions and plug a small load in to make sure the outlet is producing electricity. If you do not run it often, it will greatly shorten the generator's lifespan and void the warranty.

4. **Allow generator to run for several minutes before connecting electrical devices.** Do not start or stop engine with electrical devices plugged in to the receptacles. Failure to do so could damage the generator and/or connected electrical devices.
5. **Do not turn on electrical devices until after they are connected to the generator.**
6. **Generators vibrate in normal use.** During and after the use of the generator, inspect both the generator as well as extension and power supply cords for damage resulting from vibration.
7. **Do not touch hot parts.** This generator produces heat when running. Temperatures near exhaust can exceed 150°F (65°C). Allow generator to cool down after use before touching engine or areas of the generator that become hot during use.
8. **Turn off all connected electrical devices before stopping the generator.**
9. **Always turn generator off before refueling.** Allow generator to cool for at least 2 minutes before removing fuel cap. Loosen cap slowly to relieve pressure in tank.
10. **Turn the engine switch to “OFF” position when the engine is not running.**
11. **Empty fuel tank before storing or transporting the generator.** Do not store generator or gasoline near furnaces, water heaters, or any other appliances that produce heat or have automatic ignitions. Store the generator and fuel away from sparks, open flames, pilot lights, heat and other sources of ignition.
12. **Always wash hands after handling generator.**

CAUTION: Misuse of this generator can damage it or shorten its lifespan.

UNPACKING & PACKING LIST

UNPACKING

With the help of a friend or trustworthy foe, such as one of your in-laws, carefully remove the generator from the packaging and place it on a sturdy, flat surface. Make sure to take out all contents and accessories. Do not discard the packaging until everything is removed. Check the packing list below to make sure you have all of the parts and accessories. If any part is missing or broken, please contact customer service at **1-847-429-9263** (M-F 8-5 CST), or email techsupport@wenproducts.com.

PACKING LIST

Components

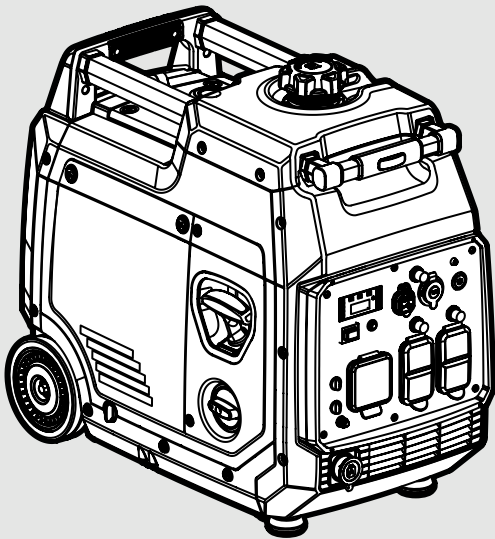

Generator

Tools & Accessories

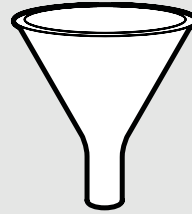

Funnel

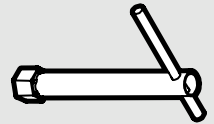

Spark Plug Socket (1)

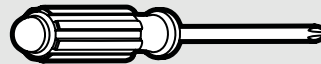

Screwdriver

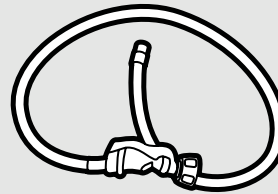

LPG Regulator Hose

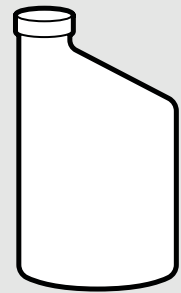

Engine Oil,
20.3 fl. oz. (0.60 L)

KNOW YOUR INVERTER GENERATOR

TOOL PURPOSE

Inverter Generators provide you with clean and quiet power, when and where you need it most. Refer to the following diagrams to become familiarized with all the parts and controls of your Generator. The components will be referred to later in the manual for assembly and operation instructions.

GENERATOR

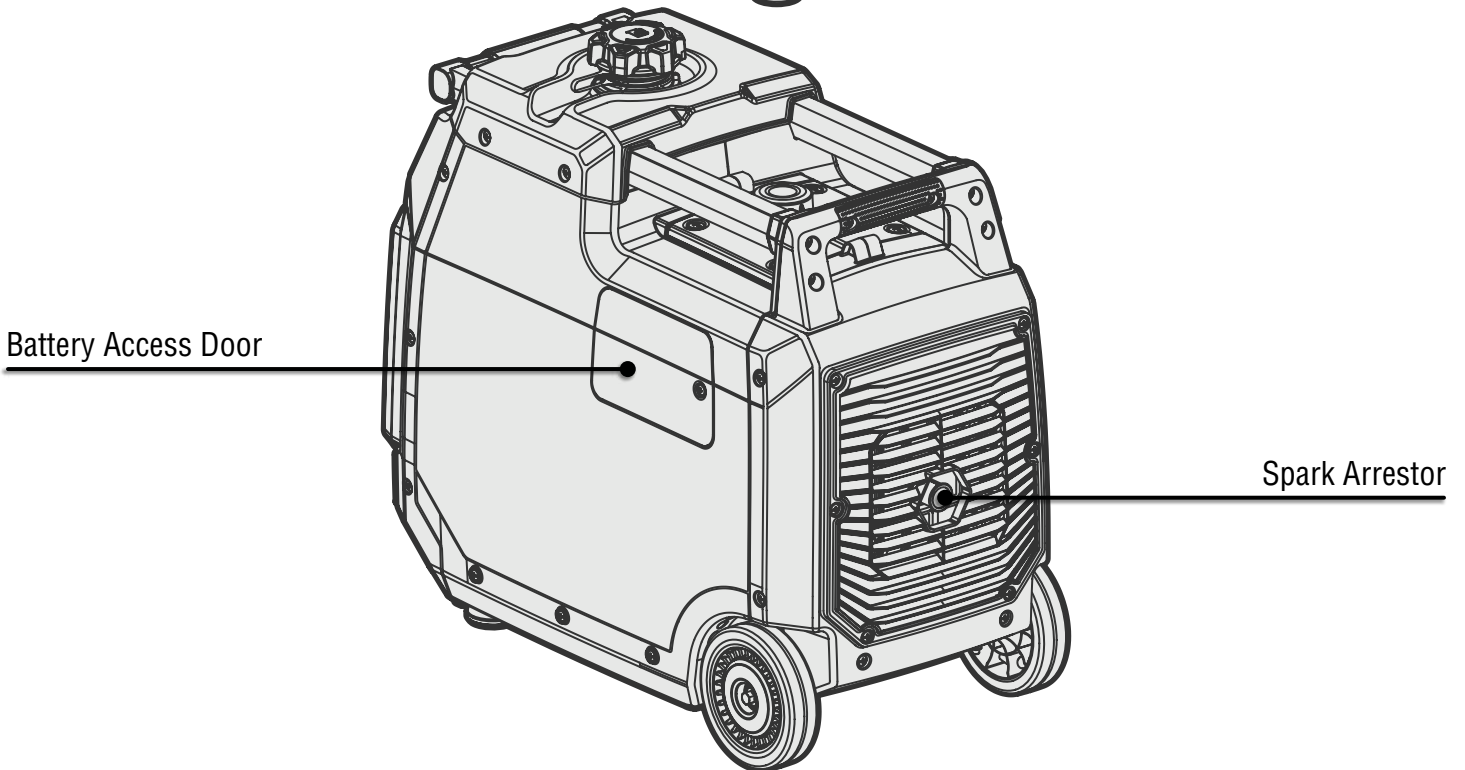
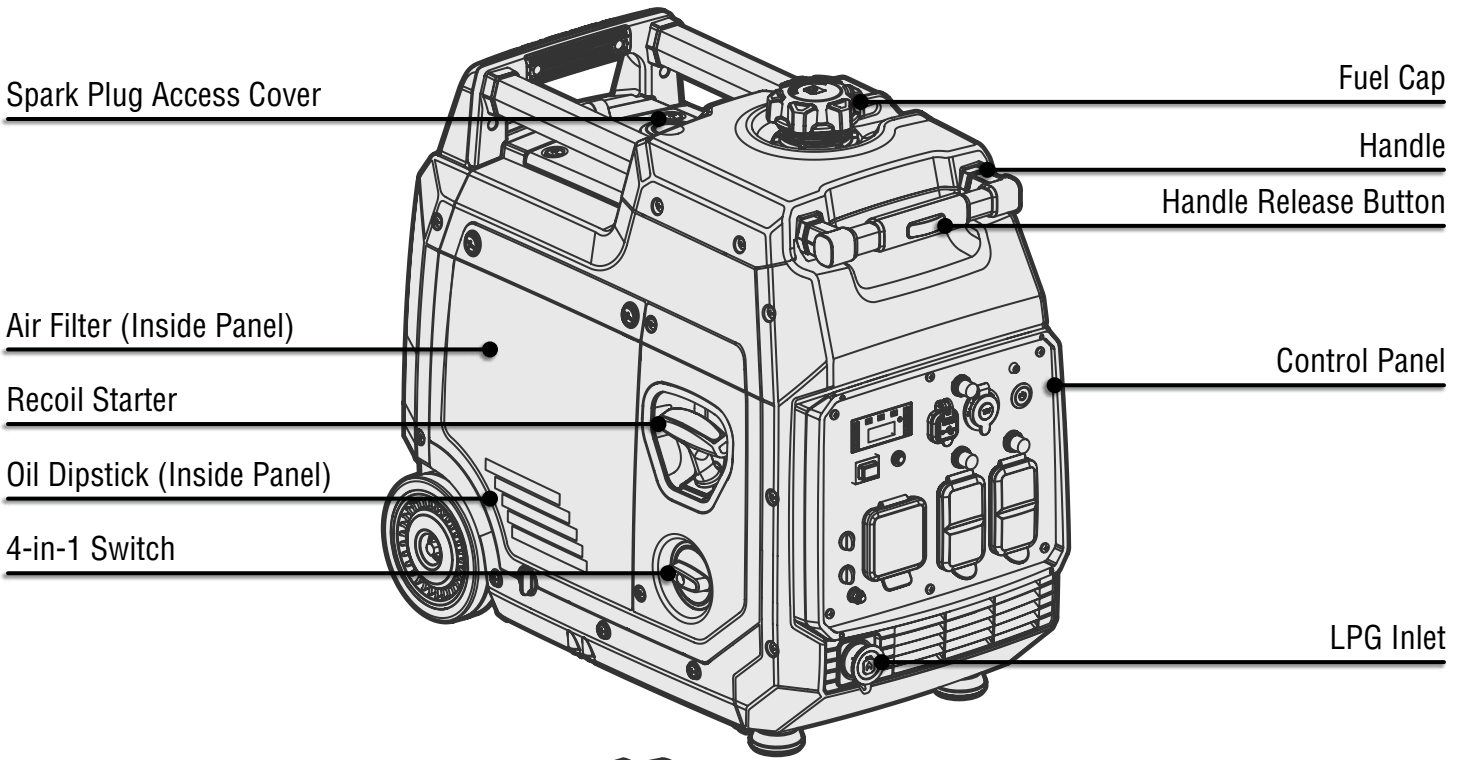

KNOW YOUR INVERTER GENERATOR

CONTROL PANEL

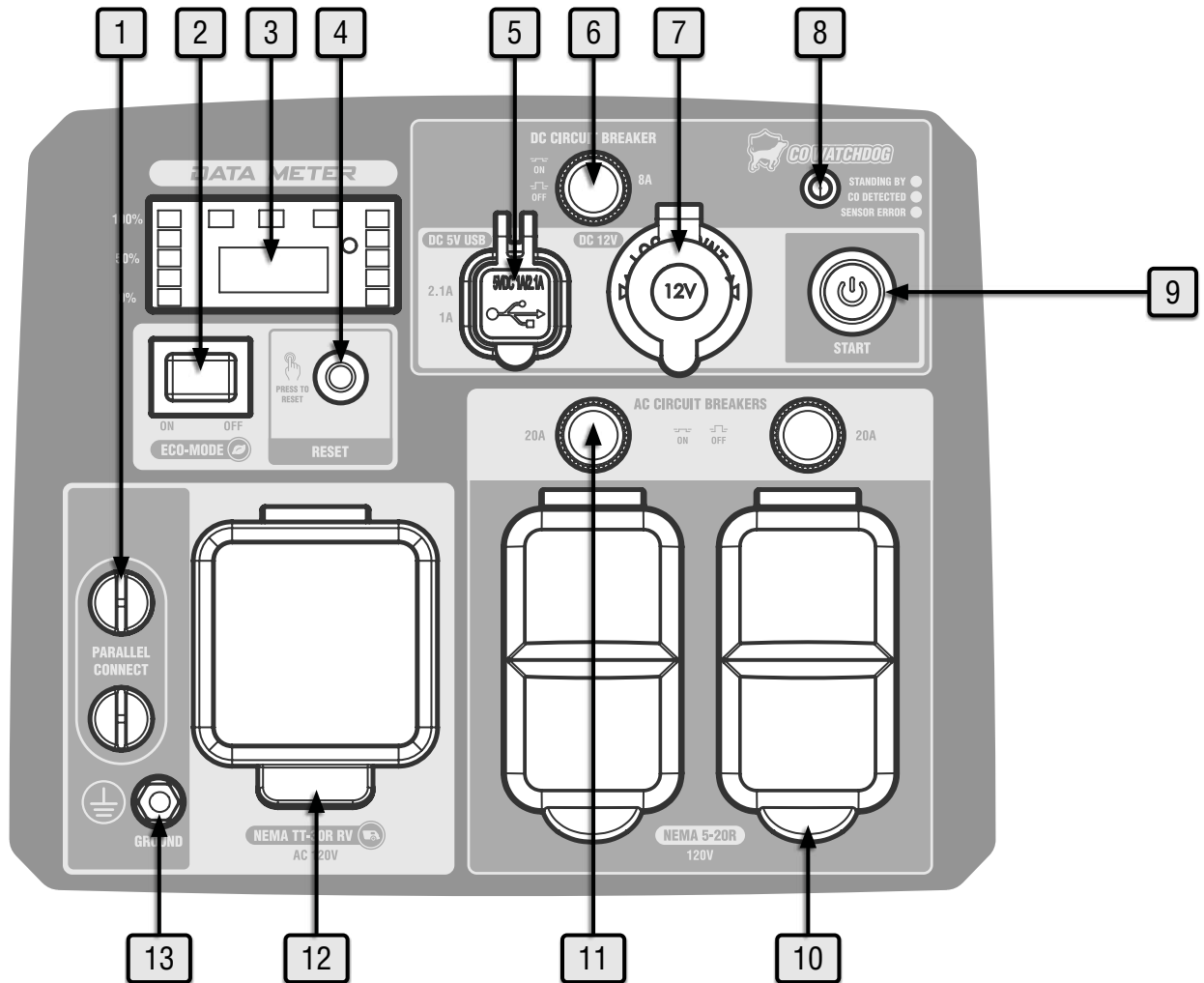

1. Parallel Connection

Connect to share wattage between inverter generators.

2. Eco-Mode Switch

Maximizes fuel economy & run time.

3. Data Meter with Indicator Light

Displays load level (left), fuel level (right), voltage (e.g. V120), frequency (e.g. F60.0), session runtime (e.g. A 0.0), and total runtime (e.g. 0.0). Press MODE to switch between displays.

4. Reset Button

Press to reset the circuit in case of overload.

5. 5V USB Port

1A & 2.1A for charging various electronic devices.

6. DC Circuit Breaker (8A)

Press to reset.

7. 12V DC Outlet

Cigarette-style outlet provides DC power.

8. CO WATCHDOG Carbon Monoxide Monitor

Measures the accumulation of poisonous CO gas while the generator is running. If the level of CO gas gets too high, the CO Watchdog system will automatically shut down the generator. See p. 26 for more information.

9. Electric Start Button

Press to start the generator.

10. AC 120V NEMA 5-20R Duplex Receptacles

Standard household outlets provide 120V 60Hz power.

11. AC Circuit Breakers (20A)

Press to reset.

12. AC 120V NEMA TT-30R RV Receptacle

Standard RV connector.

13. Grounding Nut

Ground the generator to reduce the risk of electric shock.

PREPARATION

The following section describes the necessary steps to prepare the generator for use. If you are unsure about how to perform any of the steps please call **1-847-429-9263** M-F 8-5 CST for customer service. Failure to perform these steps properly can damage the generator or shorten its life.

STEP 1 - ADD / CHECK OIL

The generator is shipped without oil. User must add the proper amount of oil before operating the generator for the first time. The oil capacity of the engine crankcase is **20.3 fl. oz.** (0.60 L).

ENGINE OIL RECOMMENDATIONS

Select good quality detergent oil bearing the American Petroleum Institute (API) service classifications SJ, SL, or SM (synthetic oils may be used). Select the SAE viscosity grade of oil that matches the expected operating temperature.

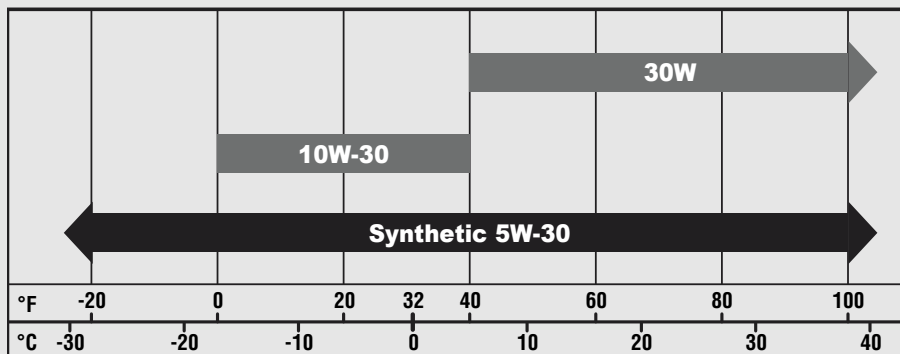

Fig. 1

- **30W Engine Oil**
Temperatures above 40°F
- **10W-30 Engine Oil**
Temperatures between 0°F - 40°F
- **Synthetic 5W-30 Engine Oil**
All temperature ranges

TO ADD OIL:

1. Place the generator on a level surface. Make sure the engine is OFF before adding or checking oil.

CAUTION! Keep the generator level. Tilting the generator to assist in filling will cause oil to flow into the wrong areas of the engine and cause damage.

1. Open the side panel (to the right of the control panel) by removing the two screws (Fig. 2 - 1) at the top of the panel. Remove and wipe the oil dipstick with a clean rag. Insert the dipstick into the oil fill opening without screwing it in.

2. Remove the dipstick (Fig. 2 - 2) to check the oil mark on the dipstick (Fig. 3). Add oil if the oil mark covers less than one half of the dipstick.

3. Slowly add oil and repeat step 2 until the oil mark measures between the upper limit mark and halfway mark of the dipstick. Do not overfill the crankcase.

4. Wipe clean any oil leaks and firmly tighten the dipstick.

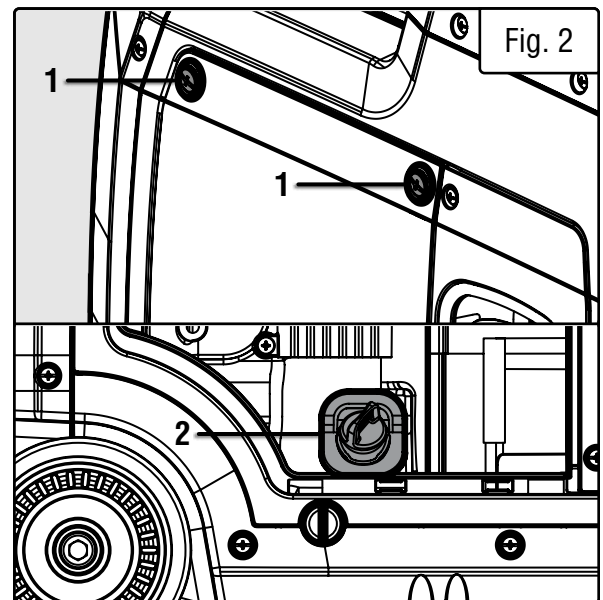

Fig. 2

CAUTION! For subsequent operation, the oil level should be checked before each use, or after every 8 hours of operation. The generator is equipped with a low-oil sensor and will not start without a sufficient amount of oil. Follow the instructions on the next page to check the oil level.

PREPARATION

TO CHECK OIL LEVEL (before every subsequent start):

1. Place the generator on a level surface. Make sure the engine is OFF before adding or checking oil.
2. Remove and wipe the dipstick with a clean rag.
3. Insert the dipstick into the oil fill without screwing it in. Remove the dipstick to check the oil mark.
4. If the oil mark covers **less than one half** of the dipstick, slowly **add oil** until the oil mark measures between the upper limit mark and halfway mark of the dipstick. See Fig. 3.

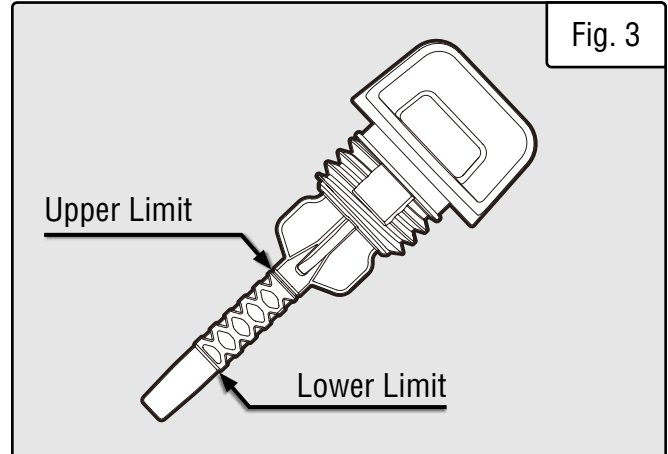

TIP: Your WEN generator is compatible with the **WEN 55201** Magnetic Oil Dipstick (not included), available for purchase at wenproducts.com. The dipstick's industrial-strength magnetic tip will collect metal shavings from your generator's oil tank to help preserve the engine and extend your generator's lifespan.

PREPARATION

STEP 2 - ADD / CHECK FUEL

FUEL OPTION A: GASOLINE

⚠ WARNING! RISK OF EXPLOSION. HIGHLY FLAMMABLE: This generator may emit highly flammable and explosive gasoline vapors, which can cause severe burns or even death, if ignited. A nearby open flame can lead to explosion even if not directly in contact with gasoline.

- Do not operate near open flame, heat, or any other ignition source. Do not smoke near the generator.
- Always operate on a firm, level surface.
- Always turn generator off before refueling. Allow generator to cool for at least 2 minutes before removing fuel cap. Loosen cap slowly to relieve pressure in tank.
- Do not overfill fuel tank. Gasoline may expand during operation. Do not fill to the top of the tank. Allow for expansion. Always check for spilled fuel before operating.
- If fuel spills, move the generator at least 30 feet away from the spill and wipe clean any spilled fuel before starting the engine.
- Empty fuel tank before storing or transporting the generator.

ONLY use fresh (within 30 days from purchase), lead-free gasoline with a **minimum of 87 octane rating**. The generator performs best with ethanol-free gasoline. **DO NOT** use gasoline with over 10% ethanol.

The capacity of the fuel tank is **1.9 gallons** (7.20 L). Do not mix oil with gasoline.

TO ADD GASOLINE:

Use fresh (within 30 days from purchase), lead-free gasoline with a minimum of 87 octane rating. The generator performs best with ethanol-free gasoline. **DO NOT** use gasoline with over 10% ethanol. The capacity of the fuel tank is 1.9 gallons. Do not mix oil with gasoline.

1. Place the generator on a level surface. Make sure the engine is off before adding or checking the fuel.
2. Unscrew the fuel cap (Fig. 4 - 1) and set it aside. The fuel cap may be tight and hard to unscrew.
3. Slowly add unleaded gasoline to the fuel tank. Be careful not to overfill. Reinstall fuel cap and wipe clean any spilled gasoline with a dry cloth.

NOTE: Do not fill the fuel tank to the very top. If you do so, gasoline will expand and spill during use, even with the fuel cap in place.

4. Reinstall fuel cap and wipe clean any spilled gasoline with a dry cloth.

IMPORTANT:

- Avoid getting dirt or water into the fuel tank.
- Keep gasoline away from sparks, open flames, pilot lights, heat, and other sources of ignition.
- Gasoline can age in the tank and make starting difficult. Never store the generator for more than 2 months with fuel in the tank.
- Never use an oil/gasoline mixture.
- Never use old gasoline.

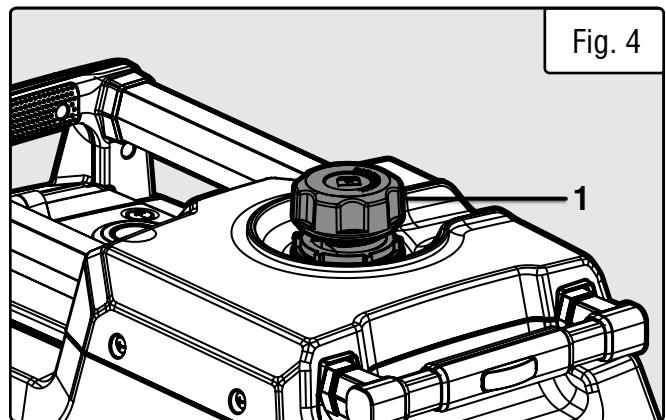

Fig. 4

PREPARATION

FUEL OPTION B: LIQUID PETROLEUM GAS (LPG)

To connect your generator to an LPG cylinder:

1. Take off the safety caps from the cylinder valve, generator mounted regulator, and regulator connecting hose ends.
2. With the LPG tank valve closed, attach the LPG regulator connecting hose (Fig. 5 - 1) to the valve. Turn the plastic coupling from the hose right (clockwise) to tighten hose assembly onto the LPG tank.
3. Remove the protective cover from the LPG inlet (Fig. 6 - 1) on the generator. Push the connector on the other end of the regulator hose into the LPG inlet until it clicks into place.
4. Turn the LPG tank valve ON and check for leaks by spraying soapy water to check connections. If bubbles appear, become larger in size, or increase in number, a leak exists. This **MUST** be corrected before using generator. Contact WEN customer service at **1-847-429-9263**, M-F 8-5 CST, or email techsupport@wenproducts.com for assistance.

NOTE: If you would like to purchase other accessories for your dual-fuel generator, consult your local dealer of propane and propane accessories, I tell you what.

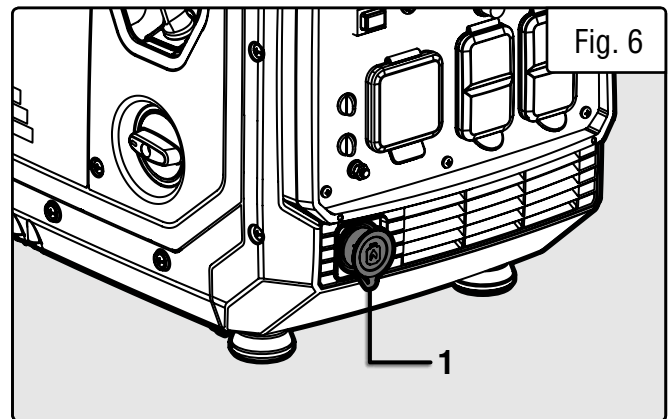
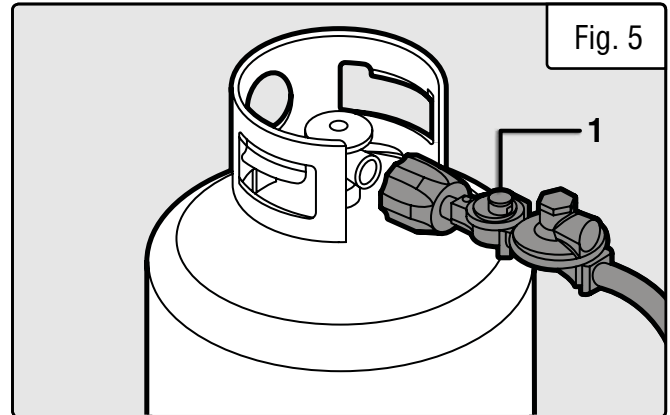

CAUTION! Always position the LPG cylinder so the connection between the tank and LPG inlet won't cause sharp bends or kinks in the hose.

WARNING! Risk of burns. Contact with liquid contents of cylinder will cause freeze burns to the skin. If liquid contents contacts skin or eyes, seek immediate medical attention.

WARNING! When transporting and storing, keep cylinder secured in an upright position with cylinder valve turned off. Keep cylinders ventilated and away from heat when in a vehicle.

PREPARATION

AUTO FUEL SELECTION

Your generator is equipped with Auto Fuel Selection Technology. What this means is that the generator will automatically select the fuel source (LPG or gasoline) depending on availability. LPG is prioritized; this means that if a propane tank with enough LPG is connected, the generator will automatically use LPG. If no propane tank is connected, the generator will use gasoline (if there is gasoline in the fuel tank). The LPG regulator hose must be disconnected for the generator to switch to gasoline. If the LPG regulator hose is connected and you run out of LPG, the generator will not automatically switch to gasoline.

NOTE: Make sure the generator can handle the load(s) you plan to connect. The generator can provide more power when running on gasoline than on LPG. Consult the specifications table on p. 3, as well as the “Calculating the Wattage of Your Device(s)” chart to ensure that your load(s) will not exceed the rated wattage for a particular fuel. See also the “Switching Fuels” section for more information.

STEP 3 - GROUND THE GENERATOR

To reduce the risk of electric shock and to maximize safety, the generator should be properly grounded.

1. Attach one end of the grounding wire to the grounding nut (Fig. 7 - 1). Tighten the nut to secure the grounding wire.
2. Connect the other end of the grounding wire to a copper, brass, or steel-grounding rod that is driven into the earth.

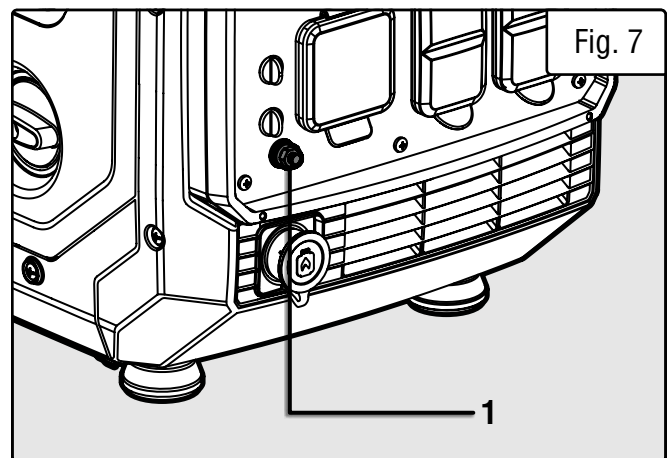

HIGH ALTITUDE OPERATION ABOVE 3000 FEET

The fuel system on this generator may be affected by operation at high altitudes. Proper operation can be ensured by installing an altitude kit at altitudes higher than 3000 feet above sea level. At elevations above 9800 feet, the engine may experience a decrease in performance, even with the proper altitude kit. Operating this generator without said kit may increase the engine’s emissions and decrease both fuel economy and performance.

This kit should be installed by a qualified mechanic. You can order the kit at wenproducts.com by searching part number **DF480iX-HA39**. Refer to the instructions included with your altitude kit for more information about installation.

WARNING! Failure to properly ground the generator increases your risk of electric shock.

NOTE: Grounding wire and grounding rods are not included with the generator. A generally acceptable grounding wire is a **No. 12 AWG (American Wire Gauge) stranded copper wire**. Grounding codes can vary by location. Contact a local electrician to check the area codes.

WARNING! To prevent serious injury from fire, follow the kit installation procedures in a well-ventilated area away from ignition sources. If the engine is hot from use, shut the engine off and wait for it to cool before proceeding. Do not smoke near the generator. Warranty will be void if adjustments are not made for high altitude use.

CAUTION! UNINSTALL the high altitude kit when operating at altitudes below 3000 feet.

PREPARATION

STEP 4 - CONNECT THE BATTERY

⚠ WARNING! Use only genuine WEN batteries with your generator (**part no. DF480iX-067**). Use of other batteries may induce premature product failure and could pose a safety risk.

ABOUT THE BATTERY

1. The lithium-ion battery supplied with your generator is only partially charged, in order to maximize its service life. The battery may not have enough charge to start the engine during its first use. If this is the case, connect the battery according to the instructions below, and start the generator using the recoil starter, according to the instructions below. The battery will receive charge when the generator is running.

2. Lithium-ion batteries are subject to a natural aging process. The battery must be replaced at the latest when its capacity falls to just 80% of its capacity when new. Weakened cells in an aged battery are no longer capable of meeting the high power requirements needed for the proper operation of your generator, and therefore pose a safety risk.

3. **DO NOT INCINERATE BATTERY.** Do not throw the battery into an open fire as this poses a risk of explosion. Do not ignite the battery or expose it to fire.

4. **AVOID DAMAGE AND SHOCKS.** Immediately replace batteries that have been dropped from a height of more than one meter (3 feet) or those that have been exposed to violent shocks, even if the housing of the battery appears to be undamaged. The battery cells inside the battery may have suffered serious damage. In such instances, please read the waste disposal information on p. 30 for proper battery disposal.

5. **DO NOT CRUSH, DROP OR DAMAGE BATTERY.** Do not use the battery if it has sustained a sharp blow, been dropped, run over or has been damaged in any way (e.g. pierced with a nail, hit with a hammer, stepped on, etc.).

6. **DO NOT DISASSEMBLE.** Incorrect reassembly may pose a serious risk of electric shock, fire or exposure to toxic battery chemicals. If the battery or charger are damaged, call WEN customer service at **1-847-429-9263** for assistance.

For more information on the battery quick-connectors, visit: <http://bit.ly/44sb6C2>

7. **DO NOT SHORT CIRCUIT.** Batteries will short circuit if a metal object makes a connection between the positive and negative contacts on the battery. Do not place the battery near anything that may cause a short circuit, such as paper clips, coins, keys, screws, nails and other metallic objects. A short-circuited battery poses a risk of fire and severe personal injury.

NOTE: The safe temperature range for charging the battery is 25°F – 104°F.

The generator is shipped with the lithium-ion battery disconnected to maximize safety. To start the generator using electric start, the battery must be connected.

To connect the battery:

1. Use the screwdriver to loosen the screw on the battery access door (Fig. 8 - 1). Open the battery access door. Connect the two ends of the quick connector on the battery (Fig. 8 - 2) to connect the battery to the generator's system.

2. Close the door and tighten the screw.

NOTE: The generator can be run with the battery disconnected or with no charge using the recoil starter.

IMPORTANT: If you do not plan to use the generator for an extended period of time, we recommend **DISCONNECTING** the quick-connector. This will protect the battery from losing its charge. After disconnecting the quick-connector, cover the ends of the cable with an insulator such as electrical tape. Alternatively, you can use a trickle charger (not included) to maintain battery charge.

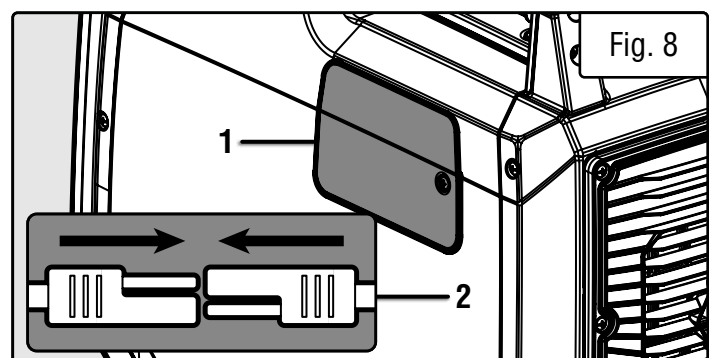

STARTING YOUR GENERATOR

Before starting the generator, make sure you have read and performed the steps in the “Preparation” section of this manual, pages 12 - 17. If you are unsure about how to perform any of the steps in this manual please call **1-847-429-9263** M-F 8-5 CST for customer service.

DANGER! CARBON MONOXIDE

Using a generator indoors **CAN KILL YOU IN MINUTES**. Generator exhaust contains carbon monoxide (CO). This is a poison gas you cannot see or smell. If you can smell the generator exhaust, you are breathing CO. But even if you cannot smell the exhaust, you could be breathing CO.

NEVER use a generator inside homes, garages, crawl spaces, or other partially enclosed areas. Deadly levels of carbon monoxide can build up in these areas. Using a fan or opening windows and doors does NOT supply enough fresh air. **ONLY** use a generator outside and far away from windows, doors, and vents. These openings can pull in generator exhaust.

Even if you use a generator correctly, CO may leak into the home. **ALWAYS** use a battery-powered or battery-backup CO alarm in the home. If you start to feel sick, dizzy, or weak after the generator has been running, move to fresh air **RIGHT AWAY**. See a doctor. You may have carbon monoxide poisoning.

 **WARNING!** The exhaust from this product contains chemicals known to the State of California to cause cancer, birth defects, or other reproductive harm.

 **WARNING!** Do not operate generator near open flame or flammable materials. This generator may emit highly flammable and explosive gasoline vapors, which can cause severe burns or even death if ignited. A nearby open flame can lead to explosion even if it isn't directly in contact with gasoline. Do not smoke near the generator.

 **WARNING!** This generator produces powerful voltage, which can result in electrocution.

 **WARNING!** Do not use in rainy or wet conditions. Do not touch bare wires or receptacles (outlets). Do not allow children or non-qualified persons to operate.

 **WARNING!** Generator should only be connected to electrical devices, either directly or with an extension cord. **NEVER** connect to a building electrical system without a qualified electrician and connected to a transfer switch as a separately derived system. Such connections must comply with local electrical laws and codes. Failure to comply can create a back-feed, which may result in serious injury or death to utility workers.

To maximize safety, **ALWAYS** ground the generator before using it. See page 16, “GROUND THE GENERATOR”.

Use a ground fault circuit interrupter (GFCI) in highly conductive areas such as metal decking or steel work. GFCIs are available in-line with some extension cords.

CAUTION! Disconnect all electrical loads from the generator before attempting to start.

Follow the instructions on the next page to start your generator.

STARTING YOUR GENERATOR

BEFORE STARTING THE GENERATOR

1. Verify that the generator is outside on a dry, level surface. Allow at least two feet of clearance on all sides of the generator.
2. To maximize safety, check that the generator is properly grounded. See page 16, "GROUND THE GENERATOR."
3. Check that there is a sufficient level of oil in the crankcase. Add oil if necessary. Refer to page 12, "STEP 1 - ADD / CHECK OIL."
4. Check that there is a sufficient level of fuel in the fuel tank. Add gas if necessary. Refer to page 14, "FUEL OPTION A: GASOLINE"
5. Make sure all electrical devices are unplugged from the generator during ignition. Otherwise it will be difficult for the engine to start.

STARTING THE GENERATOR (GASOLINE)

1. Turn the ECO-MODE switch to "OFF" during starting (Fig. 9 - 1).
2. Turn the 4-in-1 switch (Fig. 10 - 1) to the "CHOKE" position.

Option A: Electric Start

3. Press the START button (Fig. 11 - 1) and hold for 2-3 seconds until the engine starts, then release.

NOTE: The battery is shipped partially charged, in order to maximize its service life, and may not have enough charge to start the engine during the first use of the generator. If you have trouble starting the generator the first time using electric start, use the pull start option and allow the generator to run for a few hours to charge the battery.

Option B: Pull Start.

3. Place one hand on the generator to hold it in place, and pull on the recoil starter handle (Fig. 12 - 1) slowly until a slight resistance is felt. Then pull quickly to start the engine. Return cord gently into the machine. Never allow the cord to snap back.

NOTE: If engine fails to start, repeat step 3.

4. Slowly turn the 4-in-1 switch (Fig. 10 - 1) to the "RUN" position.

5. Allow the generator to run for several minutes before attempting to connect any electrical devices. This allows the generator to stabilize its speed and temperature.

NOTE: If you have repeated failed attempts to start the engine, please consult the troubleshooting guide. If problems persist, please call please call **1-847-429-9263** M-F 8-5 CST.

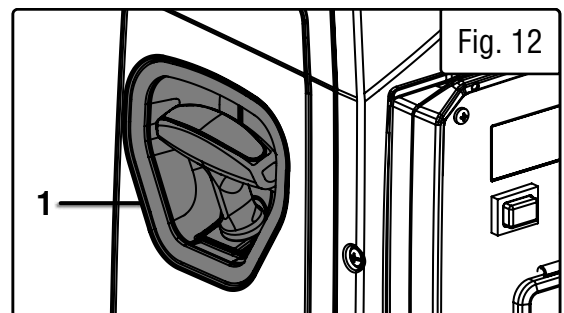
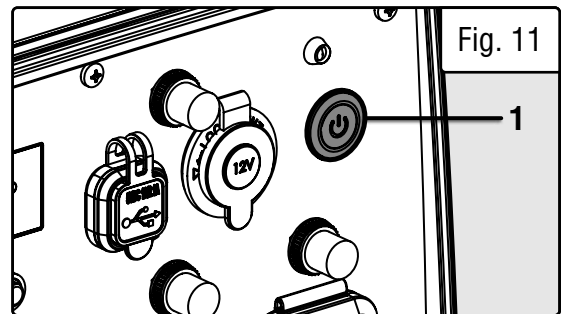
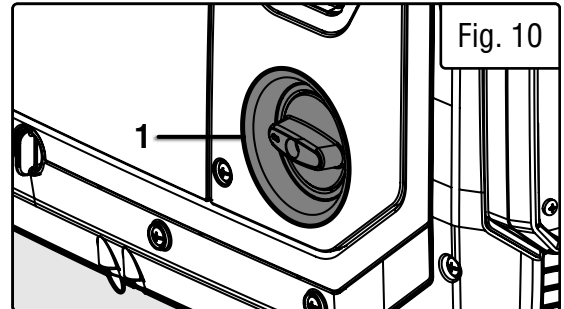
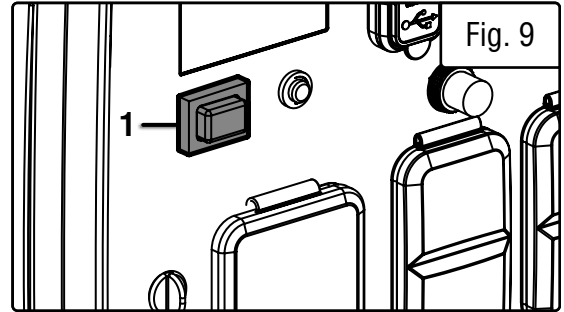

STARTING YOUR GENERATOR

STARTING THE GENERATOR (LPG)

1. Place the generator outside on a dry, level surface. Allow at least two feet of clearance on all sides of the generator.
2. Check there is sufficient level of oil in the crankcase. Add oil if necessary (refer to “ADD / CHECK OIL” on page 12).
3. Make sure that the LPG regulator hose is properly connected to the LPG tank and the inlet on the generator (refer to “FUEL OPTION B: LIQUID PETROLEUM GAS (LPG)” on page 15).
4. To maximize safety, make sure the generator is properly grounded (refer to “GROUND THE GENERATOR” on page 16).
5. Make sure all electrical devices are unplugged from the generator during ignition. Otherwise it will be difficult for the engine to start.
6. Turn the ECO-MODE switch to “OFF” during starting (Fig. 9 - 1).
7. Turn the 4-in-1 switch (Fig. 10 - 1) to the “CHOKE” position.
8. Gently pull the recoil starter handle (Fig. 12 - 1) 3 - 5 times to prime the engine.
9. Slowly turn the 4-in-1 switch (Fig. 10 - 1) to the “RUN” position.

Option A: Electric Start

10. Press the START button (Fig. 11 - 1) and hold for 2-3 seconds until the engine starts, then release.

NOTE: The battery is shipped partially charged, in order to maximize its service life, and may not have enough charge to start the engine during the first use of the generator. If you have trouble starting the generator the first time using electric start, use the pull start option and allow the generator to run for a few hours to charge the battery.

Option B: Pull Start.

10. Pull the recoil starter handle (Fig. 12 - 1) quickly to start the engine. Return the cord gently into the machine. Never allow the cord to snap back.

NOTE: If engine fails to start, repeat step 7.

11. Allow the generator to run for several minutes before attempting to connect any electrical devices. This allows the generator to stabilize its speed and temperature.

NOTE: If you have repeated failed attempts to start the engine, please consult the troubleshooting guide. If problems persist, please call please call **1-847-429-9263** M-F 8-5 CST.

STARTING YOUR GENERATOR

ECO-MODE SWITCH

This generator is equipped with an Eco-Mode Idle Control Switch (Fig. 9 - 1). Engaging the switch automatically adjusts the engine to match the load. When the electrical load changes, the generator engine will automatically speed up and slow down as needed. This reduces fuel consumption and noise levels.

Keep this switch engaged when the power load requirement is less than 3000W. Do not engage the Eco-Mode Switch when the total load is more than 3000W. The generator engine must run at full speed to supply power for anything over 3000W.

OIL LEVEL SHUTDOWN

The low oil indication light on the data meter (Fig. 13 - 1) will turn on to remind you that the engine oil level is low and need to be refilled. The generator is equipped with a low oil pressure shutoff that will automatically stop the engine when the oil level is too low to protect the unit from damage. The oil level of the engine should be checked before each start to ensure that the engine crankcase contains sufficient lubricant.

PARALLEL OPERATION

The parallel connection feature (Fig. 14 - 1) allows you to connect two WEN generators to increase the total available electrical power. The “Parallel Connection Kit” can be purchased from wenproducts.com.

Follow the instructions included with your WEN parallel connection kit for proper installation and operation.

ENGINE BREAK-IN PROCEDURE

The procedure below should be followed when you receive your generator in order to prolong the engine’s service life. This procedure helps to seat the piston rings properly in the cylinder, and will reduce overall wear on the engine.

For the first 8 hours of operation, vary the load, but keep it at or below 50% of the generator’s rated wattage, if possible. If your generator is equipped with an Eco-mode switch (only applicable for certain inverter generators), engage Eco-mode periodically during the first 8 hours. After the first 8 hours, change the oil, then change it again after the first 25 hours. You may run the generator at full load after the 8-hour oil change. Refer to the Recommended Maintenance Schedule in Table 4 for the full maintenance schedule.

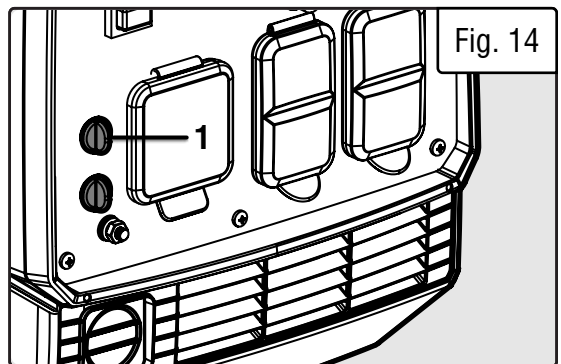
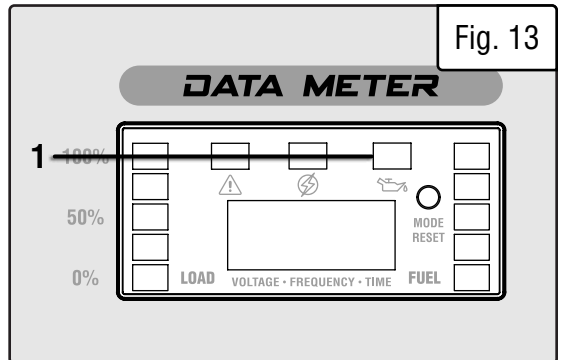

USING YOUR GENERATOR

CALCULATING THE WATTAGE OF YOUR DEVICE(S)

Connect electrical devices running on AC current according to their wattage requirements. Calculate the total running wattage and starting wattage of the device(s) you wish to connect, and **MAKE SURE** that they are within the capacity of your generator and the capacity of each individual outlet.

Generator Wattage Capacity	GENERATOR RUNNING (RATED) WATTS	GENERATOR STARTING (SURGE) WATTS
	Gasoline: 4000W	Gasoline: 4800W
	LPG: 3600W	LPG: 4320W
	<p>What this means: The generator can produce a maximum of 4000W / 3600W on a continuous basis to supply ongoing power to your electronic devices.</p> <p>NOTE: Also check the rated amperage for each outlet and make sure not to overload the individual outlets.</p>	<p>What this means: Some devices such as box fans require short bursts of extra power in addition to the rated wattage listed by the device to start their motors.</p> <p>The generator can produce a maximum wattage of 4800W / 4320W for a short period of time (seconds) to cover the extra starting power required by your electronic devices.</p>
Electronic Device Wattage Calculation	<p>Find the wattage information of each device you plan to connect. The information should be listed on the device or in its instruction manual, or you may refer to page 23, Table 2.</p> <p style="text-align: center;">The wattage can be calculated using this equation: Watts = Volts x Amperes</p>	
	<p>To calculate the total running watts of your devices:</p> <p>+ Add up the running wattages of all the device(s) you plan to connect.</p> <p>= The total running (rated) wattage.</p> <p>This wattage should NOT exceed the running wattage of 4000W / 3600W.</p> <p>It is recommended to maintain a load at or below 3600W / 3240W (90% of the rated output) to ensure steady voltage output and to prolong the generator's lifespan.</p>	<p>To calculate the total starting watts of your devices:</p> <p>+ Add up the total running wattage of all the device(s) you plan to connect.</p> <p>+ Add the single highest ADDITIONAL starting wattage out of the device(s) you plan to connect.</p> <p>= The total starting (surge) wattage.</p> <p>This wattage should NOT exceed the starting wattage of 4800W / 4320W.</p>
	<p>If any of either of the total calculated running watts or starting watts is higher than the capacity of your generator, adjust the load until both wattage requirements are met. Otherwise you will overload the generator, and cause damage to the engine and your electrical device(s).</p>	

Table 1 - How to Calculate Wattages

USING YOUR GENERATOR

CALCULATING THE WATTAGE OF YOUR DEVICE(S) - CONTINUED

The chart below serves as a reference for the estimated wattage requirements of common electrical devices. However, do not solely rely on this chart - all electronics and appliances are built differently. Always check the wattage listed on the electrical device before consulting this chart.

Tool or Appliance	Rated (Running) Watts	Surge (Starting) Watts
Electric Water Heater (40 Gal)	4000	0
Hot Plate	2500	0
Saw - Radial Arm	2000	2000
Electric Stove (Each Element)	1500-2800	0
Saw - Circular	1500	1500
Air Compressor (1 HP)	1500	3000
Window Air Conditioner	1200	1800
Saw - Miter	1200	1200
Microwave	1000	0
Well Water Pump	1000	1000
Sump Pump	800	1200
Refrigerator Freezer	800	1200
Furnace Blower	800	1300
Computer	800	0
Electric Drill	600	900
Television	500	0
Deep Freezer	500	500
Garage Door Opener	480	0
Stereo	400	0
Box Fan	300	600
Clock Radio	300	0
Security System	180	0
Dvd Player / VCR	100	0
Common Light Bulb	75	0

Table 2 - Estimated Wattages of Common Electrical Appliances

NOTE: Become familiar with the functions and capacity of each component on the control panel before connecting electrical devices. See page 11 for more information about the components of the control panel. Do not overload generator or individual panel receptacles. Do not connect 50Hz or 3-phase loads to the generator.

USING YOUR GENERATOR

CONNECTING ELECTRICAL DEVICES

When the rated wattage requirement of each electrical device has been determined, add these numbers to find the total rated wattage needed. If this number exceeds the rated wattage (4000W) of the generator, DO NOT connect all these devices. Select a combination of electrical devices with a total rated wattage lower than or equal to the rated wattage of the generator.

⚠ CAUTION! Become familiar with the markings on the control panel (Fig. 15) before connecting electrical devices. Do not connect 50 Hz loads to the generator.

1. Before connecting electrical devices, allow the generator to run for a few minutes to stabilize the speed and voltage output.
2. Make sure that all devices are turned off. Start plugging in each electric device, from the highest wattage to the lowest. Check the power indicator light (green) to ensure the generator is producing power.
3. Do not overload the generator or individual panel receptacles. If an overload occurs, the overload indication light (red) will activate. If it is flashing, turn off and unplug one load. If it is solid (not flashing), the generator will cut off power to protect itself. Unplug all electrical devices and then press the reset button to reset the entire circuit, or press the circuit breaker to reset the DC circuit. Check the total wattage of the devices and reduce the load if it exceeds the capacity of the generator. Then, plug the loads back in one by one.

NOTE: If the reset button or circuit breaker does not reset, wait several minutes and try again. If problem still persists, please call **1-847-429-9263** M-F 8-5 CST.

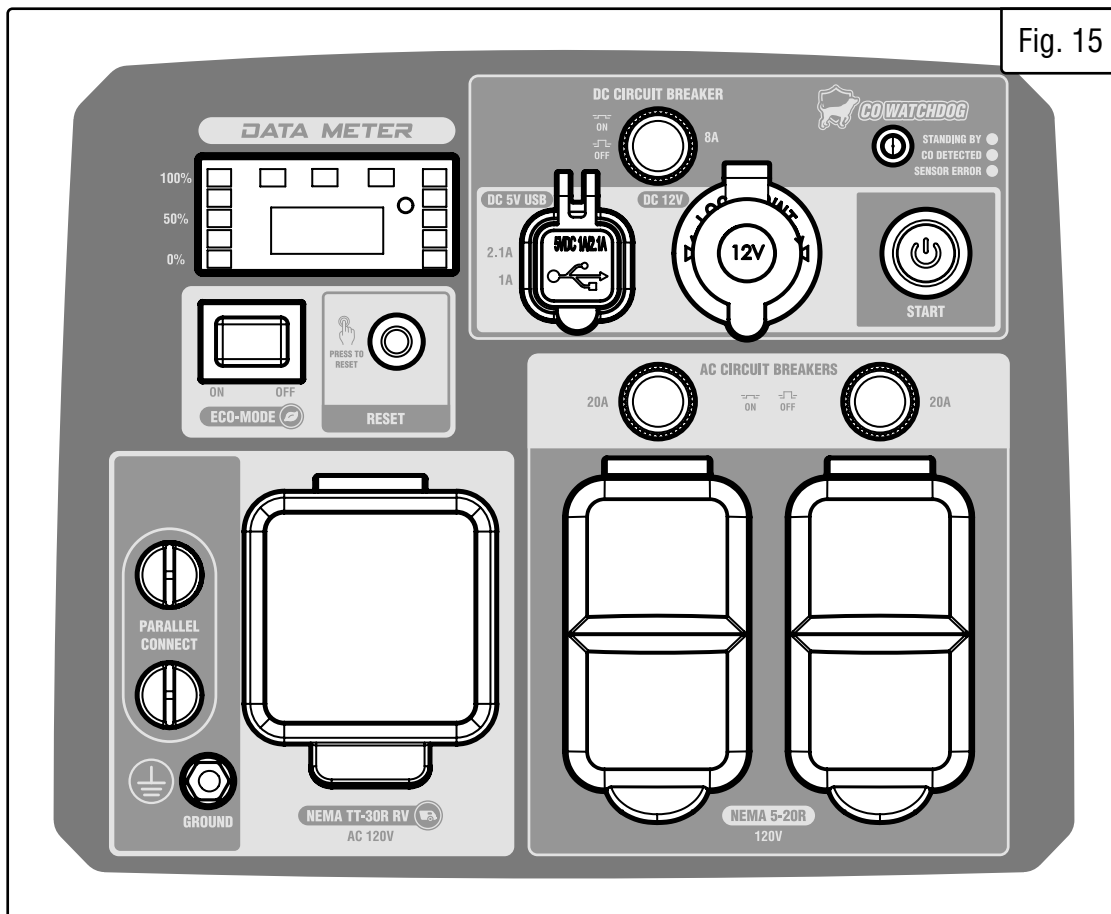

USING YOUR GENERATOR

SOME NOTES ABOUT POWER CORDS

Long or thin cords can drain the power provided to an electrical device by the generator. When using such cords, allow for a slightly higher rated wattage requirement by the electrical device.

Device Requirements			Max. Cord Length (ft) by Wire Gauge				
Amps	Watts (120V)	Watts (240V)	#8 wire	#10 wire	#12 wire	#14 wire	#16 wire
2.5	300	600	NR	NR	NR	375	250
5	600	1200	NR	NR	300	200	125
7.5	900	1800	NR	350	200	125	100
10	1200	2400	NR	250	150	100	50
15	1800	3600	NR	150	100	65	NR
20	2400	4800	175	125	75	50	NR
25	3000	6000	150	100	60	NR	NR
30	3600	7200	125	65	NR	NR	NR
40	4800	9600	90	NR	NR	NR	NR

*NR = Not Recommended

Table 3 - Power Cord Requirement Guide

⚠ WARNING! Generator should **only** be connected to electrical devices, either directly or with an extension cord. NEVER CONNECT TO A BUILDING ELECTRICAL SYSTEM without a qualified electrician and connected to a transfer switch as a separately derived system. Such connections must comply with local electrical laws and codes. Failure to comply can create a back-feed, which may result in serious injury or death to utility workers.

NOTE: For power outages, permanently installed, stationary generators are better suited for providing backup power to your home. Even a properly connected portable generator can become overloaded. This may result in overheating or stressing the machine's components, possibly leading to generator failure.

USING YOUR GENERATOR

CO SENSOR INFORMATION

The CO Watchdog carbon monoxide monitoring system (Fig. 16 - 1) measures the accumulation of poisonous CO gas while the generator is running. If the level of CO gas gets too high, the CO Watchdog system will automatically shut down the generator. **This system is not a substitute for an indoor CO alarm.**

Whenever the CO Watchdog system shuts down the generator, the LED on the generator control panel (Fig. 16 - 1) will **blink red** for at least 5 minutes after the generator is shut down. **If you notice that the LED is blinking red, vacate the area immediately.** Go to an open, outdoor area. Ventilate the area around the generator thoroughly before returning. Let the generator stay shut down for a few minutes before restarting the engine. This should allow carbon monoxide to dissipate from the area. If you restart the generator and the CO Watchdog detects that CO levels are still too high, it will shut down the generator again. If CO levels are low enough, the generator will run normally.

Ensure that the generator is located in an open outdoor area, with the exhaust pointing away from occupied structures, and pointing away from the prevailing winds, such that those winds do not blow engine exhaust towards the sensor module. If anyone experiences dizziness, headaches, nausea, fatigue, or other symptoms of CO poisoning, get to fresh air immediately and seek the attention of a qualified medical professional. Follow all other directions in this manual regarding the connection and disconnection of electrical devices when starting or shutting down the generator.

When starting the generator, the CO Watchdog LED on the panel may flash. This indicates that the system is running a self-test procedure, and does not indicate a problem.

If the CO Watchdog LED on the panel is **yellow**, a system error has occurred, or the CO sensor has reached the end of its life. Contact WEN customer service (**1-847-429-9263**, M – F 8 – 5 CST, or techsupport@wenproducts.com) for assistance.

When operating your generator, please note the following:

- The CO Watchdog does not discriminate in its input; any source of carbon monoxide in the area around the generator could cause it to activate. If the CO Watchdog LED is blinking red, safety measures should be taken immediately.
- Tampering with, disconnecting, or bypassing the CO sensor could cause hazardous conditions, including but not necessarily limited to injury or death, and will void your warranty. The generator will not run with the CO sensor disconnected or bypassed, or if the CO sensor indicates an error.
- The CO sensor has a lifetime of about 7 years, and is capable of monitoring its lifetime. If your generator shows an error light several years after purchase, it may be time to replace the CO sensor. Contact WEN customer service for assistance.

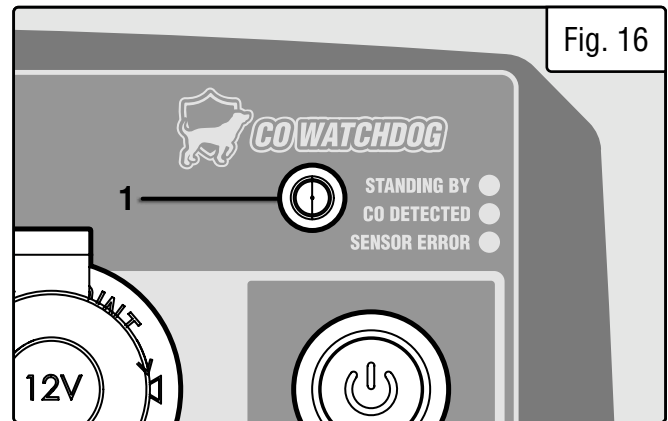

Fig. 16

NOTE: if the generator is oriented so that the engine exhaust is blown towards the CO sensor, the generator may shut down.

STOPPING YOUR GENERATOR

SHUTTING OFF THE GENERATOR

1. Turn off all electrical devices and then unplug the devices from the generator.

⚠ CAUTION! Unplugging running devices can cause damage to the generator. Never stop the engine with electrical devices connected and running.

2. Allow generator to run at no load for a few minutes to stabilize internal temperatures.

3. Turn the 4-in-1 switch (Fig. 17 - 1) to the “FUEL OFF” position.

4. If using LPG, turn the LPG tank valve OFF and remove the LPG regulator hose from the tank and inlet on the generator. Push the collar on the LPG quick-connector back to release the end of the LPG regulator hose.

5. The engine will continue to run until the majority of the fuel in the carburetor is consumed, which takes a few minutes. It will then shut off automatically. This feature helps to prevent the carburetor from being clogged by stale fuel, extending your generator’s lifespan.

6. Once the engine switches OFF, turn the 4-in-1 switch to the “ENGINE OFF” position.

7. In case you are in a hurry and do not want to wait for the generator to automatically shut down, turn the 4-in-1 switch to the “ENGINE OFF” position and the generator will shut off right away. However, this method will leave stagnant fuel in the carburetor, possibly causing blockages, a shortened lifespan, and other maintenance issues. If this approach is frequently taken, make sure to drain your carburetor before any long storage periods.

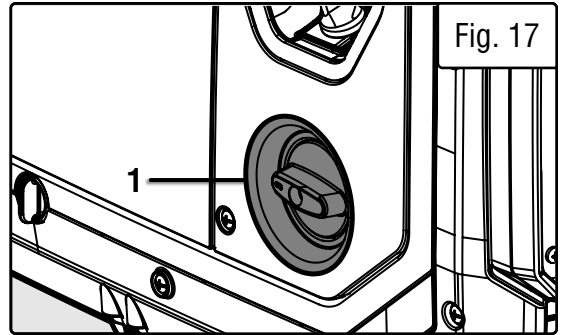

⚠ WARNING! Allow the generator to cool for several minutes before touching areas that become hot during use.

⚠ CAUTION! Allowing gasoline to sit in the fuel tank for long periods of time can make it difficult to start the generator in the future. Never store the generator for extended periods of time (over 2 months) with fuel in the fuel tank. Refer to “Storing the Generator”.

MAINTENANCE

Proper routine maintenance of the generator will help prolong the life of the machine. Please perform maintenance checks and operations according to the schedule in Table 4.

⚠ CAUTION! Never perform maintenance operations while the generator is running. Before maintaining or servicing the generator, turn OFF the generator, disconnect all devices and allow the generator to cool down.

If there are any questions about the maintenance procedures listed in this manual, please call **1-847-429-9263** M-F 8-5 CST or email techsupport@wenproducts.com.

Recommended Maintenance Schedule		Every 8 Hours or Daily	Every 25 Hours	Every 3 Months or 50 Hours	Every 6 Months or 100 Hours	Before Storage	As Necessary
Engine Oil	Check Level	x					
	Replace	x**	x**	x*			x
Air Filter	Check			x*			
	Clean			x*			
Spark Plug	Check/Clean/Regap				x		
	Change				x		x
Fuel	Check Level	x					
	Drain					x	x
Carburetor	Drain	x					x
Spark Arrestor	Check/Clean				x		

* Clean/change more often under dusty conditions or operating under heavy load. Table 4 - Recommended Maintenance Schedule

** Change the oil after the first 8 hours of operation, after the first 25 hours of operation, and every 50 hours after that.

IMPORTANT GENERATOR MAINTENANCE TIPS:

- Drain your carburetor after each use and before storage to prevent it from clogging.
- Do not store the generator with fuel inside the tank for more than 2 months - the fuel will go bad.
- Run the generator for at least 20 minutes every month to maximize lifespan.

CLEANING THE GENERATOR

Keep the generator clean to prevent improper operation or machine damage from dirt and debris. Inspect all ventilation openings on the generator. These openings must be kept clean and unobstructed. If the generator becomes dirty, use a damp cloth to wipe exterior surfaces. Use a soft bristle brush to loosen dirt and oil and use a vacuum to pick up loose dirt. Use low pressure air (not to exceed 25 PSI) to blow away dirt.

⚠ CAUTION! Never clean the generator when it is running! Never clean with a bucket of water or a hose. Water can get inside the working parts of the generator and cause corrosion or a short circuit.

NOTE: Failure to properly maintain the generator will void the warranty.

MAINTENANCE

⚠ WARNING! Make sure generator is shut off before performing any inspection or maintenance procedures.

CHECKING / ADDING OIL

Check the oil level of the generator according to the Recommended Maintenance Schedule in Table 4. The oil level should be checked before each use or every 8 hours of operation. The oil capacity of the generator engine is 20.3 fl. oz. (0.60 L). Add oil when the oil level is low.

For proper type and weight of oil refer to “ADD / CHECK OIL” section on page 12. The generator is equipped with an automatic shutoff to protect it from running on low oil. To check the oil level:

1. Make sure the generator is on a level surface. Do not tilt the generator to assist in filling, as oil will flow into engine areas and cause damage. Keep generator level!
2. Open the side panel (to the right of the control panel) by removing the side panel access screws (Fig. 18 - 1). Remove and wipe the oil dipstick (Fig. 19) with a clean rag. Insert the dipstick into the oil fill opening without screwing it in.
3. Insert the dipstick into the oil fill opening without screwing in. Remove the dipstick to check the oil mark. Add oil if the oil mark covers less than one half of the dipstick.
4. Using a funnel or appropriate dispenser, slowly add more oil. Repeat step 3 until the oil mark measures between the upper limit mark and half-way mark of the dipstick. Do not over fill the crankcase.
5. Reinstall dipstick and wipe clean any spilled oil with a rag.

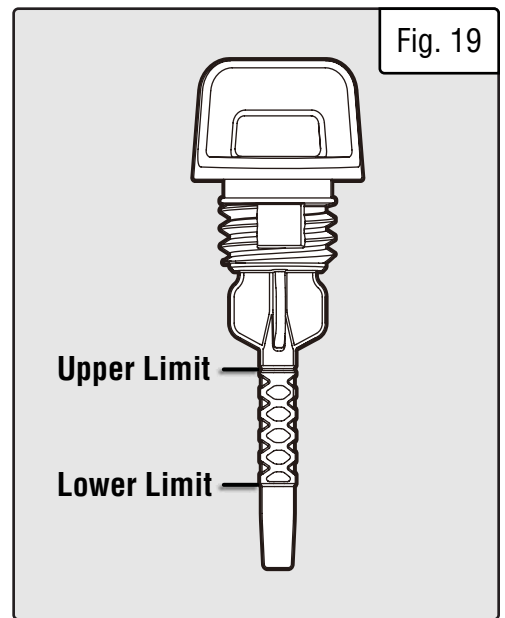
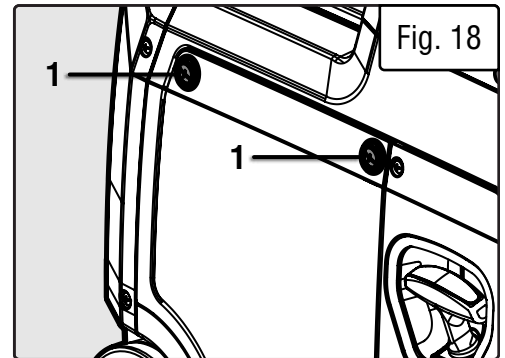

DRAINING / CHANGING THE OIL

Change the oil according to the Recommended Maintenance Schedule in Table 4. Change the oil more often if operating under heavy load or high ambient temperatures. It is also necessary to drain the oil from the crankcase if it has become contaminated with water or dirt. Changing the oil when the engine is warm allows for complete drainage. Drain the oil from the generator according to the following steps.

1. Place generator on an elevated platform such as table or desk. Prepare a container underneath the oil fill to catch the oil as it drains.
2. Open the side panel. Remove the dipstick and tilt the generator towards you to allow the oil to drain from the engine completely.
3. Reinstall the oil dipstick and tighten it securely. Wipe clean any oil spillage and close the side panel.

NOTE: Do not dispose of used motor oil in the trash or down a drain. Please call a local recycling center or auto garage to arrange proper oil disposal.

MAINTENANCE

SPARK PLUG MAINTENANCE

The spark plug is important for proper engine operation. A good spark plug should be intact, free of deposits, and properly gapped. Refer to Recommended Maintenance Schedule in Table 4 for instructions on maintaining. To inspect the spark plug:

1. Open the spark plug access cover (Fig. 20 - 1) by removing the four screws (Fig. 20 - 2).
2. Pull up to remove the black plastic spark plug boot. Be careful not to tear any insulation or wire.
3. Use a spark plug wrench to unscrew and remove the spark plug from the engine.
4. Visually inspect the spark plug for cracks or excessive electrode wear. If the electrodes are worn or burned, or porcelain is cracked, replace with an **LG F6RTC (NGK BPR6ES)** spark plug (**Part No. 56477i-163**), available at wenproducts.com.
5. If re-using the spark plug, use a wire brush to clean any dirt from around the spark plug base then re-gap the spark plug.
6. Measure the plug gap with a wire gauge (Fig. 21). The gap should be 0.024 in. - 0.031 in. (0.6mm - 0.8mm). Carefully adjust the gap if necessary.
7. Screw the spark plug back into the spark plug hole by hand. After the spark plug is properly seated, use the spark plug wrench to tighten it.

NOTE: The recommended tightening of the spark plug is 1/2 to 3/4 of a turn after the spark plug gasket contacts the spark plug hole, or 11 - 14.5 ft-lbs (15 - 20 Nm). Do not over-tighten the spark plug.

8. Reinstall the spark plug boot over the spark plug.
9. Reinstall the spark plug access cover.

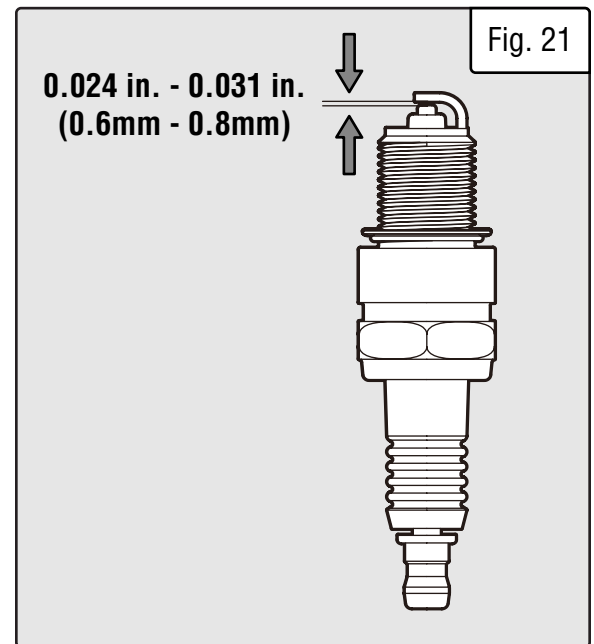
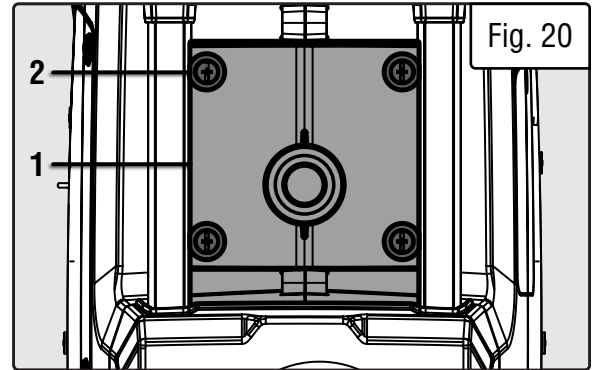

MAINTENANCE

AIR FILTER MAINTENANCE

Routine maintenance of the air filter helps maintain proper airflow to the carburetor. Occasionally check that the air filter is free of excessive dirt. The air filter should be checked every 50 hours of use. Refer to Recommended Maintenance Schedule in Table 4.

1. Open the side panel (to the right of the control panel) by unscrewing the side panel access screws (Fig. 22 - 1).
2. Unscrew the air filter cover knob (Fig. 23 - 1), remove the cover, and remove the foam air filter element from the casing.
3. Check and clean the foam air filter element. Wash the filter element in warm soapy water. Squeeze it thoroughly dry in a clean cloth. Saturate the element in clean engine oil and squeeze off excess oil in a clean absorbent cloth. A small amount of oil in the element is normal and necessary for the engine to work properly. If the element is damaged, replace it with a new one (**part. no. 56477i-103, available at wenproducts.com**).
4. Reinstall the air filter element and the air filter cover. Replace the side cover and secure it with the screws.

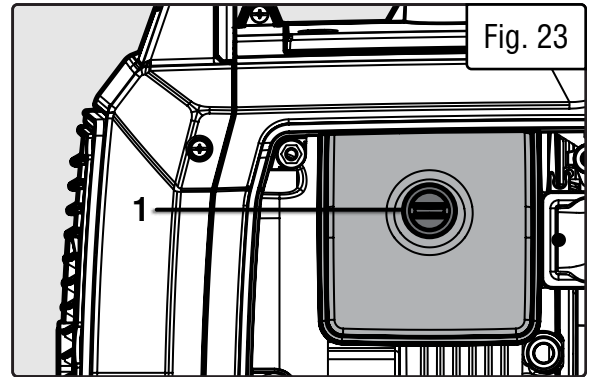
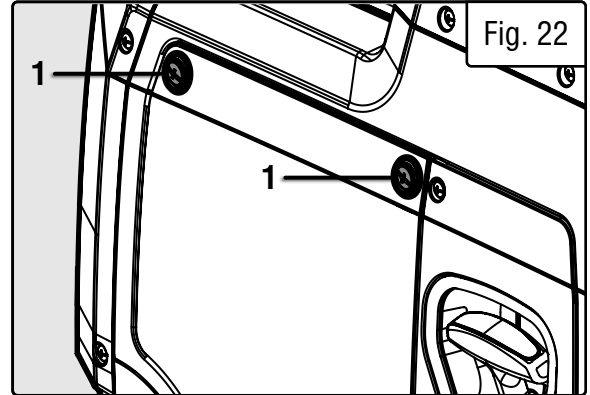

⚠ CAUTION! Running the engine with a dirty, damaged, or missing air filter element will result in possible danger and cause the engine to wear out prematurely.

DRAINING THE CARBURETOR

Drain the carburetor after every use and before storing the generator (refer to Table 4). Draining the carburetor can help prevent build-up and blockages caused by stagnant fuel inside of the carburetor.

1. Prepare an approved gasoline storage container.
2. Open the side panel (to the right of the control panel) by unscrewing the mounting screws (Fig. 22 - 1).
3. Open up the carburetor drain screw (Fig. 24 - 1) with a Phillips screwdriver and drain out any gasoline that has built up inside the carburetor.
4. Once the fuel has drained, tighten the drain screw with the screwdriver.

NOTE: Make sure to drain your carburetor before storing the generator for long periods of time.

5. Close the side panel.

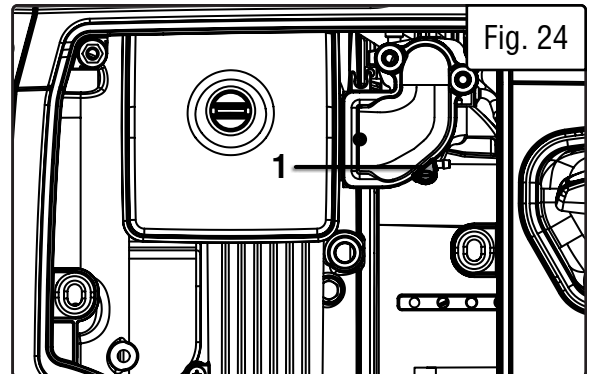

MAINTENANCE

SPARK ARRESTOR MAINTENANCE

It is recommended to inspect and clean the spark arrestor (Fig. 25 - 1) every 100 hours of operation.

1. The spark arrestor is located outside the muffler, which gets very hot during operation. Allow the engine to cool completely before servicing the spark arrestor.
2. Unscrew the six Phillips head screws and remove the muffler cover.
3. Remove the screw that holds the spark arrestor (Fig. 25 - 1) to the muffler.
4. Remove the spark arrestor screen.
5. Carefully clean and remove the carbon deposits from the spark arrestor screen with a wire brush. Replace the spark arrestor if it is damaged (**part no. 56477i-115**, available for purchase at **wenproducts.com**).
6. Reinstall the spark arrestor in the muffler and secure it in place with the screw.
7. Replace the muffler cover and secure it with the six screws.

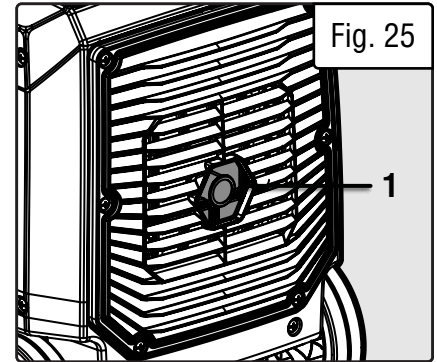

DRAINING THE FUEL TANK

1. Prepare an approved gasoline-storage container. Make sure the engine switch is turned to OFF.
2. Open the right side panel to access the carburetor, as instructed on the previous page.
3. Open the carburetor drain screw and turn the 4-in-1 switch to "RUN". This will allow gasoline to drain from the gas tank through the carburetor.

NOTE: It may take a few hours for your tank to drain completely, depending on the amount of gasoline in the tank.

4. Once drained fully, close the carburetor drain screw, turn the engine switch OFF, and close the side panel.

⚠ CAUTION! Running the engine with a dirty, damaged, or missing air filter will result in possible danger and cause the engine to wear out prematurely.

BATTERY MAINTENANCE & STORAGE

The lithium-ion battery will receive charge when the engine is running. Remember to run the generator once a month for 20-30 minutes to charge the battery. A charged battery will allow you to start the generator using the electric start button during your next time of need. If the battery is out of charge, you may start the generator using the recoil starter. If the generator is not used for a long period, it is recommended to disconnect the quick-connector to protect it from losing charge. **TIP:** You can also connect the battery to an automatic trickle charger to keep the battery charged. If using a trickle-charger, charge the battery at room temperature.

Lithium-ion batteries can be damaged or suffer a shortened lifespan if they are charged in very cold temperatures (below freezing). If you expect to store the generator in temperatures below 25°F (-5°C), we recommend removing the battery from the generator and storing it indoors. If using the generator in temperatures below 25°F (-5°C), we recommend running the generator for at least 15 minutes with the battery removed, or the quick-connector disconnected and covered with an insulator such as electrical tape, and then connecting the battery. This will allow the inside of the generator to warm up, and will greatly reduce the chance of damage to the battery.

⚠ WARNING! It is best to store the battery indoors at room temperature. Do not store your battery outside in the winter, where temperatures may go below 25°F (-5°C), or in any location where temperatures may exceed 104°F (40°C), such as in direct sunlight or inside a vehicle or metal building during the summer.

TRANSPORTATION & STORAGE

TRANSPORTING THE GENERATOR

To prevent fuel spillage when transporting, be sure to perform the following:

1. To extend or collapse the handle, press the handle release button, adjust the handle as desired, then release the button. The handle will automatically lock in the fully-extended and the locked positions.
2. Tighten the fuel cap.
3. Flip the 4-in-1 switch to the “ENGINE OFF” position.
4. Drain the fuel tank if possible. Refer to page 32, “DRAINING THE FUEL TANK.”

⚠ WARNING! Avoid direct sunlight inside a vehicle. If the generator is left in an enclosed vehicle for many hours, the high temperature could cause the fuel to vaporize and result in a possible explosion.

5. Keep the generator upright. Never place the generator on its side or upside down - doing so could damage the internal components of the generator and make it difficult to start.

STORING THE GENERATOR

Shut off the generator and allow the unit to cool to room temperature before storing it. NEVER place any type of storage cover on the generator while it is still hot. Do not obstruct any ventilation openings.

For Short Periods (30 to 60 Days):

- Drain the carburetor. Refer to page 31, “DRAINING THE CARBURETOR.”
- Disconnect the battery quick-connectors.
- **Add fuel stabilizer:** Follow the suggested portions and instructions of your preferred stabilizer. Run the engine for 15 to 20 minutes, allowing the fuel stabilizer to mix with the gasoline and circulate through the carburetor, and then top off with fuel. Filling the fuel tank full reduces the amount of air in the tank and helps fight deterioration of fuel.

For Extended Periods (Over 60 Days):

- Drain the fuel tank and carburetor (see “DRAINING THE FUEL TANK”). Never store generator with fuel in the tank for more than two months.
- Disconnect the battery quick-connectors.
- Change the engine oil (see “CHANGING OIL”).

⚠ WARNING! Store the generator upright in a cool and dry location, away from sources of heat, open flames, sparks or pilot lights.

Follow the procedures below for properly storing your generator. We highly recommend running your generator once a month for 20 to 30 minutes. Plug in a small load in to ensure there is proper power output.

PRODUCT DISPOSAL

Do not dispose of a used generator or parts with your household waste. This product contains electrical or electronic components that should be recycled. Please take this product to your local recycling facility for responsible disposal to minimize its environmental impact.

Do not dispose of used oil or fuel in the trash or down a drain. Please contact your local recycling center or auto garage to arrange proper oil/fuel disposal.



Please recycle the packaging and electronic components where facilities exist. Please contact your local auto garage or recycling facility to properly dispose of oil/fuel.

TROUBLESHOOTING GUIDE

⚠ WARNING! Stop using the generator immediately if any of the following problems occur or risk serious personal injury. If you have any questions, please contact customer service at **1-847-429-9263** (M-F 8-5 CST), or email **techsupport@wenproducts.com**.

PROBLEM	POSSIBLE CAUSE	SOLUTION
Engine will not start.	Engine switch is set to OFF.	Set engine switch to ON.
	Choke is open.	Close the choke.
	Engine is out of fuel.	Add fuel.
	Battery is out of power.	Electric start will not work if battery is out of power. Start generator using the recoil start to charge the battery.
	Battery is too cold.	Store the generator in a warmer location.
	Engine is filled with contaminated or old fuel.	Drain the fuel in the tank. Fill with fresh fuel.
	Spark plug is dirty.	Clean the spark plug.
	Spark plug is broken.	Replace spark plug.
	Oil level is low.	Add or replace oil. This generator is equipped with a low oil sensor. The engine will not start unless the oil level is sufficient.
	Carburetor is air locked.	Remove the nut from the bottom of the carburetor. Take off the carburetor to allow it to reset. Place the carburetor back and reinstall the nut.
Engine runs but there is no electrical output.	LPG cylinder is out of fuel, and LPG regulator hose is connected.	Disconnect LPG regulator hose from generator. Make sure there is enough gasoline in the tank.
	Circuit breaker has been tripped due to overload.	Disconnect all the loads. Wait for two minutes and push the circuit breaker to the ON position to reset it.
	Bad connecting cords/wires.	Check the power cords and extension cords. Do not use if any cord is damaged. Replace damaged cords immediately.
Generator runs but does not support all electrical devices connected.	Bad electrical device connected to the generator.	Try connecting a different device.
	Generator is overloaded.	Perform these steps: 1. Turn off all electrical devices. 2. Unplug all electrical devices. 3. Turn off generator. 4. Wait several minutes. 5. Restart generator. 6. Try connecting fewer electrical loads to the generator.
	Short circuit in one of the devices.	Try disconnecting any faulty or short-circuited electrical loads.
Engine is "Hunting" during Operation (Engine RPM is fluctuating).	The air filter is dirty.	Clean or replace the air filter element (see page 31).
	1. The fuel isn't running through the fuel valve. 2. The air filter is clogged. 3. The muffler or spark arrestor is blocked 4. There is gunk in the carburetor preventing a consistent fuel/air mixture.	Turn off the generator and wait for it to cool down. Perform the following steps: 1. Check if the fuel is properly and consistently going through the fuel valve 2. Check for any blockage in the air filter. Check and clean the air filter as necessary. 3. Check if the spark arrestor is blocked. Clean with metal brush as necessary. 4. Use "Gunk remover" spray on the carburetor jets.

WIRING DIAGRAM

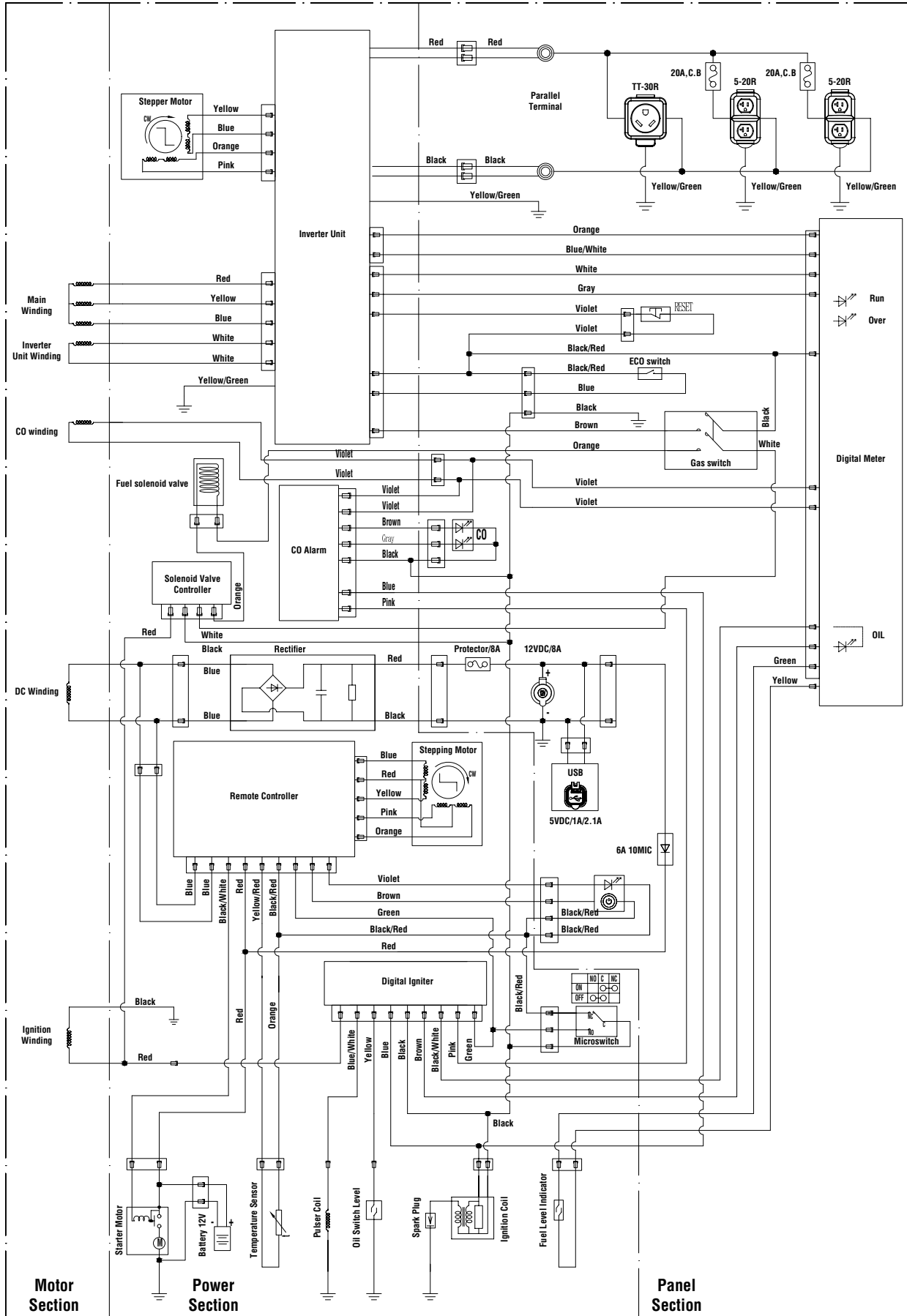

EXPLODED VIEW & PARTS LIST

GENERATOR

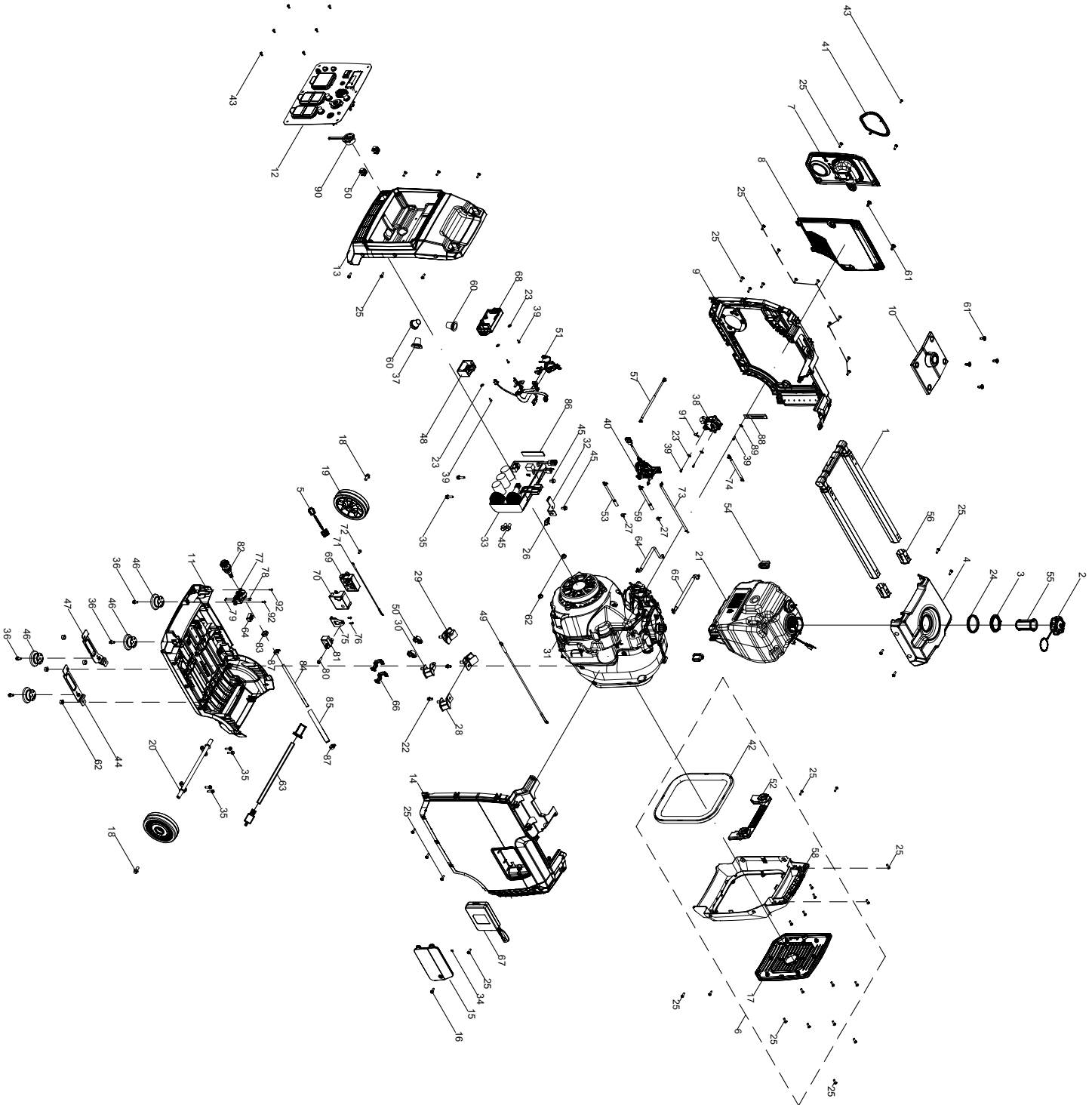

NOTE: Not all parts may be available for purchase. Parts and accessories that wear down over the course of normal use are not covered under the warranty.

EXPLODED VIEW & PARTS LIST

GENERATOR

NO.	PART NO.	DESCRIPTION	QTY.	NO.	PART NO.	DESCRIPTION	QTY.
1	DF480iX-001	Handle Assembly	1	35	56477i-035	Bolt, M6x22	6
2	DF480iX-002	Fuel Tank Cap	1	36	56202i-051	Bolt, M6x12	4
3	DF480iX-003	Fuel Tank Nut	1	37	56360iX-108	Wiring Sheath, 25mm	1
4	DF480iX-004	Top Cover	1	38	56477i-038	Fuel Pump	1
5	56480iX-005	Wiring Harness	1	39	56477i-039	Self-tapping Screw, ST3.5x13	6
6	DF480iX-006	Rear Cover Assembly	1	40	56477i-040B	Combination Fuel Valve and Engine Switch	1
7	56477i-007	Left Front Service Panel	1	41	56477i-041	Recoil Starter Shield	1
8	DF480iX-008	Left Rear Service Panel	1	42	56477i-042	Muffler Panel Gasket	1
9	56477i-009	Left Housing	1	43	56202i-001	Screw, M4x10	7
10	56477i-010	Cylinder Head Cover	1	44	56477i-044	Bottom Bracket 2	1
11	56477i-011	Base	1	45	56202i-013	Bolt, M6x12	4
12	DF480iX-012	Control Panel Assembly	1	46	56477i-046B	Foot	4
13	DF480iX-013	Front Cover	1	47	56477i-047	Bottom Bracket 1	1
14	56477i-014B	Right Housing	1	48	56480iX-048	Igniter	1
15	56477i-015	Battery Cover Panel	1	49	56477i-049	Grounding Wire	1
16	56477i-016	Phillips Bolt, M4x10.7	1	50	56477i-050	Clip	4
17	56477i-017	Muffler Panel	1	51	DF480iX-051	Wiring Harness	1
18	56477i-018	Bolt, M8x12	2	52	DF480iX-052	Handle Cover	1
19	DF480iX-019	Wheel	2	53	DF480iX-053	Fuel Hose	1
20	56477i-020	Axle Assembly	1	54	56477i-054	Fuel Tank Bumper	2
21	DF480iX-021	Fuel Tank	1	55	DF480iX-055	Fuel Filter	1
22	56477i-022	Bolt, M8x25	2	56	56477i-056	Handle Plug	2
23	56477i-023	Washer, 4mm	5	57	DF480iX-057	Fuel Hose	1
24	DF480iX-024	Bushing	1	58	DF480iX-058	Rear Cover	1
25	56477i-025	Phillips Screw, M5x12	45	59	56477i-059B	Fuel Hose	1
26	DF480iX-026	Clip	1	60	56477i-060	Wiring Sheath with Notch	2
27	56360iX-118	Clamp	2	61	56477i-061	Phillips Bolt, M6x5.5	6
28	56477i-028	Engine Mount 1	2	62	56477i-062	Nut, M8	6
29	56477i-029	Engine Mount 2	1	63	DF480iX-063	Wiring Harness	1
30	56477i-030	Engine Mount 3	1	64	DF480iX-064	Wiring Harness	1
31	DF480iX-031	Engine Assembly	1	65	DF480iX-065	Fuel Hose	1
32	56477i-032	Inverter Mounting Bracket	1	66	56477i-065	Wiring Clamp	2
33	56477i-033	Inverter	1	67	DF480iX-067	Battery, 12V 1.6Ah, Li-ion	1
34	56477i-034	Retaining Ring, 4mm	1				

EXPLODED VIEW & PARTS LIST

GENERATOR

NO.	PART NO.	DESCRIPTION	QTY.	NO.	PART NO.	DESCRIPTION	QTY.
68	56480iX-068	Remote Start & Electric Start Module	1	81	DF360iX-034	Solenoid Valve Controller	1
69	56360iX-125	CO Alarm	1	82	DF480iX-082	LPG Quick-connector	1
70	56480iX-070	CO Sensor Shield Housing	1	83	DF480iX-083	Nut, M12	1
71	56480iX-071	Grounding Wire	1	84	DF480iX-084	LPG Hose	1
72	56480iX-072	Bolt, M4x12	1	85	DF480iX-085	LPG Hose Jacket	1
73	DF480iX-073	Fuel Hose	1	86	DF480iX-086	Mounting Plate	1
74	56477i-068	Fuel Hose	1	87	DF480iX-087	Fuel Hose Clamp, 16mm	2
75	DF480iX-075	Mounting Plate	1	88	DF480iX-088	Clip	1
76	DF480iX-076	Self-tapping Screw, ST4.2x16	2	89	DF480iX-089	Washer, 4mm	1
77	DF480iX-077	Mounting Base	1	90	DF480iX-090	LPG Quick-Connector Cap	1
78	DF480iX-078	Screw, M2.5x20	2	91	56477i-069	Clamp	1
79	DF480iX-079	Nut, M2.5	2	92	DF480iX-093	Self-tapping Screw, ST4.2x20	2
80	DF480iX-080	Bolt, M6x16	1	N.P.	DF480iX-092	LPG Regulator Hose Assembly	1

EXPLODED VIEW & PARTS LIST

ENGINE

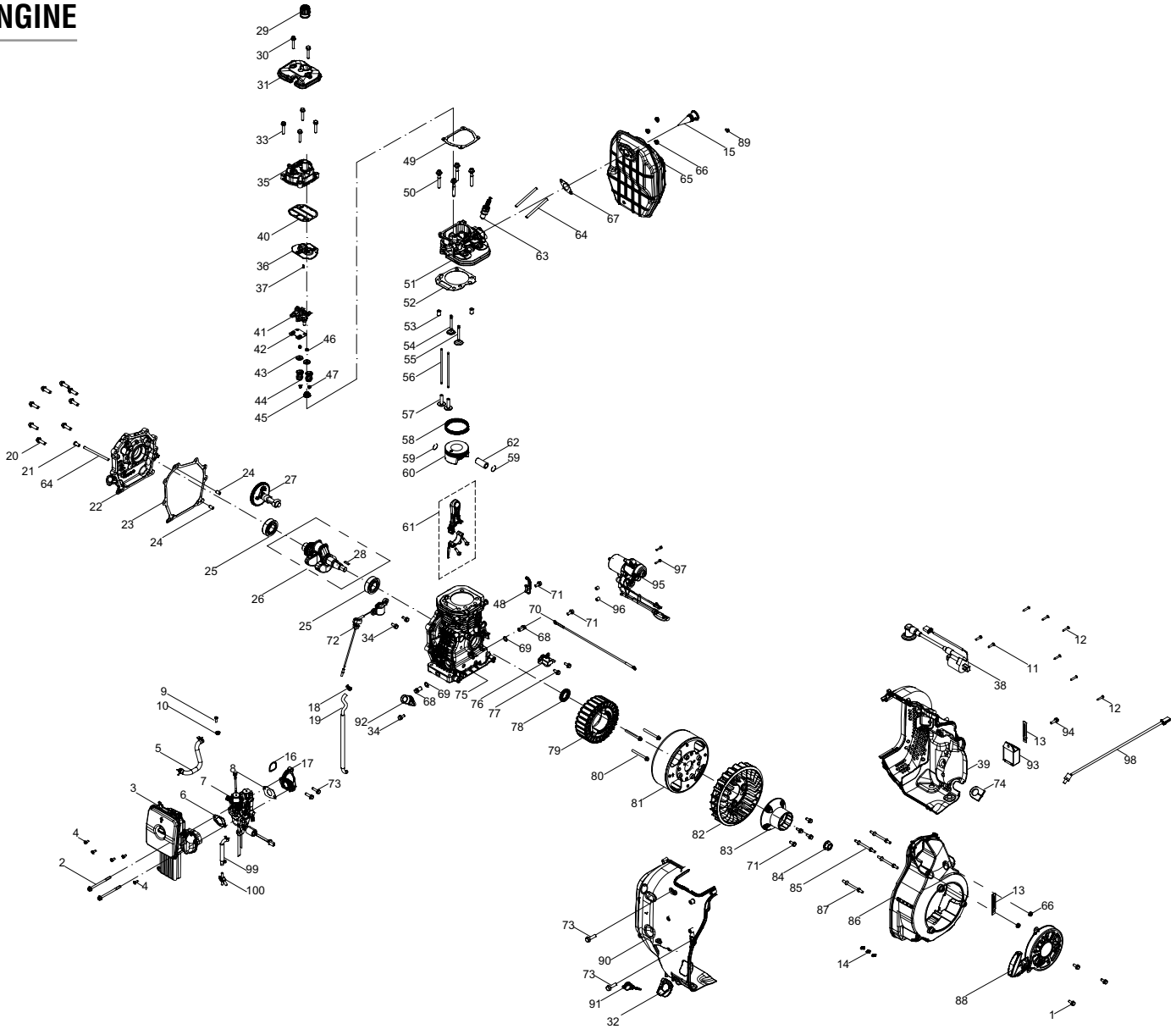

NO.	PART NO.	DESCRIPTION	QTY.	NO.	PART NO.	DESCRIPTION	QTY.
1	56477i-101	Bolt, M6x14	3	13	56360iX-084	Clip	2
2	56477i-102	Bolt, M6x85	2	14	56360iX-082	Clip	3
3	56477i-103	Air Filter Assembly	1	15	56477i-115	Spark Arrester	1
4	56477i-104	Bolt, M5x12	5	16	56477i-116	Intake Manifold Gasket	1
5	56477i-105	Breather Hose	1	17	56477i-117	Intake Manifold	1
6	56477i-106	Air Filter Gasket	1	18	56360iX-029	Clamp	1
7	DF480iX-107	Carburetor	1	19	56477i-119	Fuel Hose	1
8	56477i-108	Carburetor Gasket	1	20	56477i-120	Bolt, M8x30	8
9	56480iX-109	Screw, M4x8	1	21	56477i-121	Bushing, 12x16.8-8.5x6.5	1
10	56480iX-110	Nut, M4	1	22	56477i-122	Crankcase Cover	1
11	56477i-111	Self-tapping Screw, ST4.8x20	2	23	56477i-123	Crankcase Gasket	1
12	56360iX-087	Self-tapping Screw, ST4.2x25	6	24	56477i-124	Pin, 8x14	2

EXPLODED VIEW & PARTS LIST

ENGINE

NO.	PART NO.	DESCRIPTION	QTY.	NO.	PART NO.	DESCRIPTION	QTY.
25	56360iX-070	Bearing, TM6205	2	65	56477i-165	Muffler Assembly	1
26	56477i-126	Crankshaft	1	66	56477i-166	Nut, M6	5
27	56477i-127	Camshaft	1	67	56477i-167	Muffler Gasket	1
28	56477i-128	Woodruff Key	1	68	56477i-168	Grounding Bolt, M10-1.25x15	2
29	56477i-129	Valve Cover Cushion	1	69	56477i-169	Washer, 10 x 1.5 x 16	2
30	56477i-130	Bolt, M6x10	2	70	56477i-170	Grounding Wire	1
31	56477i-131	Cylinder Head Plastic Cover	1	71	56477i-171	Bolt, M6x16	6
32	56477i-132	Dipstick Drip Guard	1	72	56477i-172	Oil Sensor	1
33	56477i-133	Bolt, M6x25	4	73	56477i-173	Bolt, M6x22	4
34	56477i-134	Bolt, M6x16	3	74	56477i-174	Gasket, Wire	1
35	56477i-135	Cylinder Head Cover	1	75	56477i-175	Crankcase	1
36	56477i-136	Valve Cover Plate	1	76	56477i-176	Trigger	1
37	56477i-137	Bolt, M5x10	1	77	56360iX-093	Bolt, M6x12	2
38	56477i-138	Ignition Coil	1	78	56360iX-055	Oil Seal, 25 x 41.25 x 6	1
39	56477i-139	Engine Cowling, Right	1	79	56480iX-179	Stator	1
40	56477i-140	Valve Cover Plate Gasket	1	80	DF480iX-180	Bolt, M6x50	3
41	56477i-141	Rocker Arm Assembly	2	81	56480iX-181	Rotor	1
42	56477i-142	Rocker Arm Base	1	82	56477i-182	Cooling Fan	1
43	56477i-143	Valve Spring Seat	2	83	56477i-183	Starter Cup	1
44	56477i-144	Valve Spring	2	84	56477i-184	Nut, M14-1.5	1
45	56477i-145	Intake Valve Seal	1	85	56477i-185	Stud	2
46	56477i-146	Valve Adjustment Cap	2	86	56477i-186	Blower Housing	1
47	56477i-147	Valve Locker	4	87	56477i-187	Stud	2
48	56477i-148	Clip Base	1	88	DF480iX-189	Recoil Starter	1
49	56477i-149	Cylinder Head Cover Gasket	1	89	56477i-189	Self-tapping Screw, ST4.2x9.5	1
50	56360iX-015	Bolt, M8x60	4	90	56477i-190	Engine Cowling, Left	1
51	DF480iX-151	Cylinder Head	1	91	56477i-191	Dipstick	1
52	56477i-152	Cylinder Head Gasket	1	92	56477i-192	Dipstick Seat Assembly	1
53	56360iX-085	Pin, Ø10x16	2	93	56477i-109	Rectifier	1
54	56477i-154	Exhaust Valve	1	94	56202i-167	Bolt, M6x14	1
55	56477i-155	Intake Valve	1	95	DF480iX-196	Starter Motor	1
56	56477i-156	Push Rod	2	96	56480iX-195	Pin, 8x8	2
57	56360iX-038	Valve Tappet	2	97	56480iX-196	Bolt, M6x30	2
58	56477i-158	Piston Ring Set	1	98	56480iX-197	Temperature Sensor	1
59	56477i-159	Circlip	2	99	56477i-193	Fuel Hose	1
60	56477i-160	Piston	1	100	56477i-194	Fuel T-Pipe	1
61	56477i-161	Connecting Rod Assembly	1	N.P.	DF480iX-HA39	High-Altitude Kit, 3000 - 9000 ft	1
62	56477i-162	Piston Pin	1				
63	56477i-163	Spark Plug, LG F6RTC (NGK BPR6ES)	1				
64	56477i-164	Stud	3				

EXPLODED VIEW & PARTS LIST

CONTROL PANEL

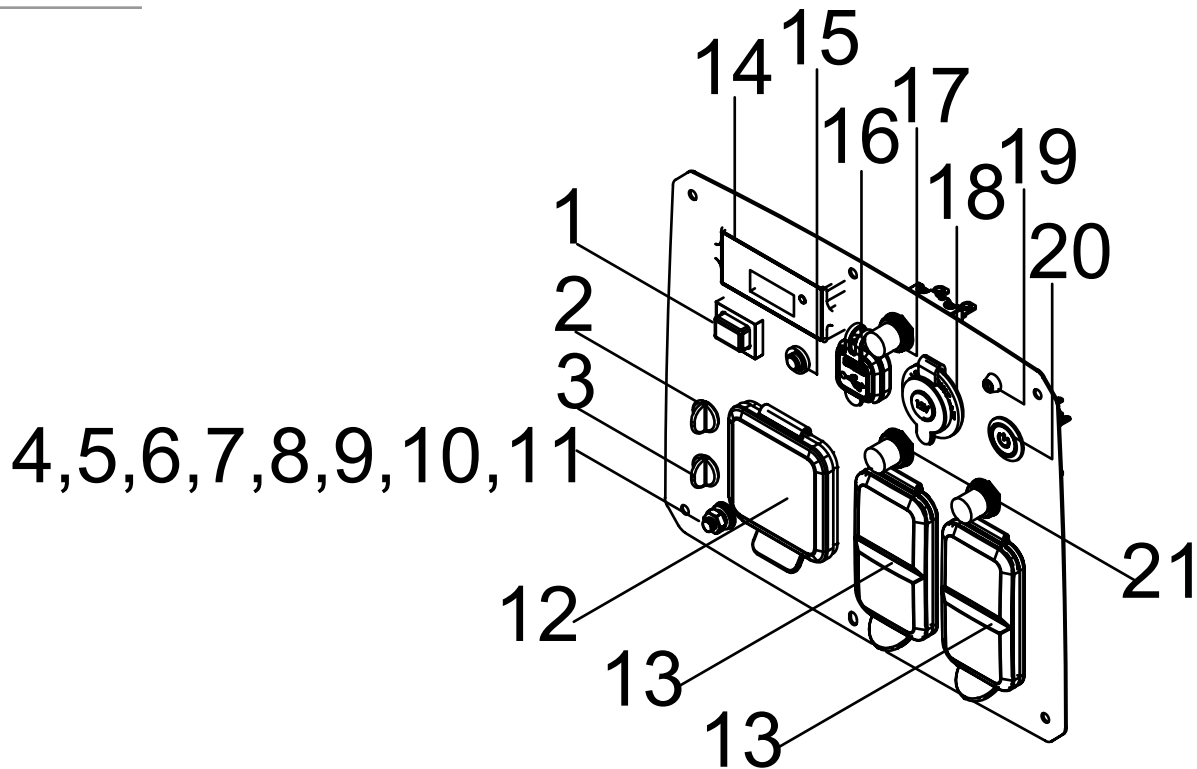

NO.	PART NO.	DESCRIPTION	QTY.
1	56203i-005.4	Eco-Mode Switch	1
2	56203i-005.14R	Parallel Socket, Red	1
3	56203i-005.14B	Parallel Socket, Black	1
4	56360iX-205	Nut, M6	1
5	56203i-005.11	Lock Washer, 6mm	1
6	56203i-005.12	Flat Washer, 6mm	1
7	56360iX-208	Grounding Stud	1
8	56360iX-209	Toothed Lock Washer, 6mm	1
9	56360iX-210	Flat Washer, 5mm	1
10	56360iX-211	Lock Washer, 5mm	1
11	56360iX-212	Nut, M5	1
12	DG4500iX-207	NEMA TT-30R 120V 30A AC Receptacle	1

NO.	PART NO.	DESCRIPTION	QTY.
13	DG4500iX-208	NEMA 5-20R 120V 20A AC Duplex Receptacle	2
14	DF480iX-214	Multi-meter	1
15	56477i-215	Reset Button	1
16	56477i-216	USB Receptacle (2.1A / 1A)	1
17	56477i-217	DC Breaker, 8A	1
18	56477i-218	12V DC Automotive Outlet	1
19	56235iX-005.19	CO Sensor LED	1
20	56480iX-220	Start Button	1
21	DF480iX-221	AC Breaker, 20A	2

NOTE: Not all parts may be available for purchase. Parts and accessories that wear down over the course of normal use are not covered under the warranty.

WARRANTY STATEMENT

WEN Products is committed to building tools that are dependable for years. Our warranties are consistent with this commitment and our dedication to quality.

LIMITED WARRANTY OF WEN PRODUCTS FOR HOME USE

GREAT LAKES TECHNOLOGIES, LLC (“Seller”) warrants to the original purchaser only, that this WEN consumer product will be free from defects in material or workmanship during personal use for a period of three (3) years from date of purchase or 500 hours of use; whichever comes first. Ninety days for all WEN products if the tool is used for professional or commercial use. Purchaser has 30 days from the date of purchase to report missing or damaged parts. Parts and labor are covered for one (1) year under this limited warranty; parts only are covered for three (3) years under this limited warranty.

SELLER’S SOLE OBLIGATION AND YOUR EXCLUSIVE REMEDY under this Limited Warranty and, to the extent permitted by law, any warranty or condition implied by law, shall be the replacement of parts, without charge, which are defective in material or workmanship and which have not been subjected to misuse, alteration, careless handling, mis-repair, abuse, neglect, normal wear and tear, improper maintenance, improper storage, incorrect lubricants / fuels, or other conditions adversely affecting the Product or the component of the Product, whether by accident or intentionally, by persons other than Seller. To make a claim under this Limited Warranty, you must make sure to keep a copy of your proof of purchase that clearly defines the Date of Purchase (month and year) and the Place of Purchase. Place of Purchase must be a direct vendor of Great Lakes Technologies, LLC. Purchasing through third party vendors, including but not limited to garage sales, pawn shops, resale shops, or any other secondhand merchant, voids the warranty included with this product. Contact techsupport@wenproducts.com or 1-847-429-9263 with the following information to make arrangements: your shipping address, phone number, serial number, required part numbers, and proof of purchase. Damaged or defective parts and products may need to be sent to WEN before the replacements can be shipped out.

Upon the confirmation of a WEN representative, your product may qualify for repairs and service work. When returning a product for warranty service, the shipping charges must be prepaid by the purchaser. The product must be shipped in its original container (or an equivalent), properly packed to withstand the hazards of shipment. The product must be fully insured with a copy of the proof of purchase enclosed. There must also be a description of the problem in order to help our repairs department diagnose and fix the issue. Repairs will be made and the product will be returned and shipped back to the purchaser at no charge for addresses within the contiguous United States.

THIS LIMITED WARRANTY DOES NOT APPLY TO ITEMS THAT WEAR OUT FROM REGULAR USAGE OVER TIME, INCLUDING FILTERS, SPARK PLUGS, VOLTAGE REGULATORS, BRUSHES, GASKETS, O-RINGS, WHEEL KITS, BATTERIES, RECOIL STARTERS, HIGH PRESSURE HOSES, SPRAY GUNS, ETC. ANY IMPLIED WARRANTIES SHALL BE LIMITED IN DURATION TO THREE (3) YEARS FROM DATE OF PURCHASE. SOME STATES IN THE U.S. AND SOME CANADIAN PROVINCES DO NOT ALLOW LIMITATIONS ON HOW LONG AN IMPLIED WARRANTY LASTS, SO THE ABOVE LIMITATION MAY NOT APPLY TO YOU.

IN NO EVENT SHALL SELLER BE LIABLE FOR ANY INCIDENTAL OR CONSEQUENTIAL DAMAGES (INCLUDING BUT NOT LIMITED TO LIABILITY FOR LOSS OF PROFITS) ARISING FROM THE SALE OR USE OF THIS PRODUCT. SOME STATES IN THE U.S. AND SOME CANADIAN PROVINCES DO NOT ALLOW THE EXCLUSION OR LIMITATION OF INCIDENTAL OR CONSEQUENTIAL DAMAGES, SO THE ABOVE LIMITATION OR EXCLUSION MAY NOT APPLY TO YOU.

THIS LIMITED WARRANTY GIVES YOU SPECIFIC LEGAL RIGHTS, AND YOU MAY ALSO HAVE OTHER RIGHTS WHICH VARY FROM STATE TO STATE IN THE U.S., PROVINCE TO PROVINCE IN CANADA AND FROM COUNTRY TO COUNTRY.

THIS LIMITED WARRANTY APPLIES ONLY TO ITEMS SOLD WITHIN THE UNITED STATES OF AMERICA, CANADA AND THE COMMONWEALTH OF PUERTO RICO. FOR WARRANTY COVERAGE WITHIN OTHER COUNTRIES, CONTACT THE WEN CUSTOMER SUPPORT LINE. FOR WARRANTY PARTS OR PRODUCTS REPAIRED UNDER WARRANTY SHIPPING TO ADDRESSES OUTSIDE OF THE CONTIGUOUS UNITED STATES, ADDITIONAL SHIPPING CHARGES MAY APPLY.

**THANKS FOR
REMEMBERING**

