

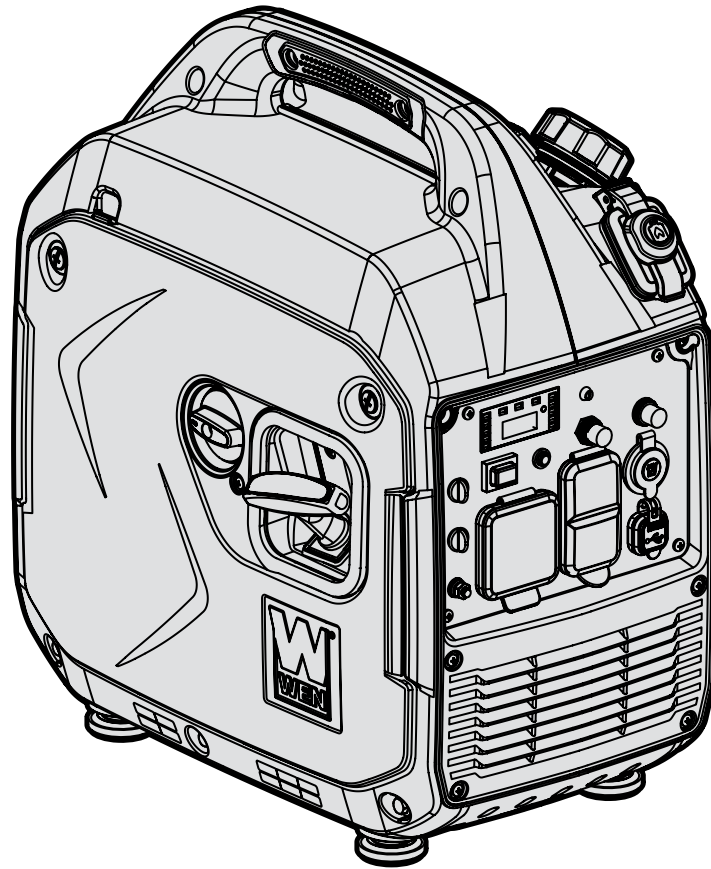

**MODEL DF360iX**

# ***3600W DUAL FUEL INVERTER GENERATOR***

**Instruction Manual**



## ***NEED HELP? CONTACT US!***

Have product questions? Need technical support? Please feel free to contact us:



**1-847-429-9263 (M-F 8AM-5PM CST)**



**TECHSUPPORT@WENPRODUCTS.COM**

**IMPORTANT:** Your new tool has been engineered and manufactured to WEN's highest standards for dependability, ease of operation, and operator safety. When properly cared for, this product will supply you years of rugged, trouble-free performance. Pay close attention to the rules for safe operation, warnings, and cautions. If you use your tool properly and for its intended purpose, you will enjoy years of safe, reliable service.

For replacement parts and the most up-to-date instruction manuals, visit ***WENPRODUCTS.COM***

# CONTENTS

<b>WELCOME</b>	<b>3</b>
Specifications.....	3
Introduction .....	4
<b>SAFETY</b>	<b>5</b>
Safety Information .....	5
Generator Safety Warnings .....	6
<b>BEFORE OPERATING</b>	<b>9</b>
Unpacking & Packing List.....	9
Know Your Inverter Generator.....	10
Preparation .....	12
<b>OPERATION &amp; MAINTENANCE</b>	<b>13</b>
Starting Your Generator .....	15
Using Your Generator.....	18
Stopping Your Generator .....	23
Maintenance.....	24
Transportation & Storage.....	29
Troubleshooting Guide.....	30
Wire Diagram.....	31
Exploded View & Parts List.....	32
Warranty Statement .....	37

To purchase accessories for your tool, visit ***WENPRODUCTS.COM***

**Magnetic Oil Dipstick** (Model No. 55201)

**Weatherproof Generator Cover** (Model No. 56200iC)

**High-Altitude Kit** (Part No. DF360iX-HA39)

**WEN Parallel Connection Kit**

# SPECIFICATIONS

## GENERATOR

Model Number	DF360iX
Surge (Starting) Wattage	Gasoline: 3600W
	LPG: 3500W
Rated (Running) Wattage	Gasoline: 2900W
	LPG: 2600W
Rated Voltage	120V
Rated Amperage	24.1A
Phase	Single
Frequency	60 Hz
Product Weight	49.60 Pounds (22.5 kg)
Product Dimensions	17.913 in. x 11.653 in. x 19.685 in.

## ENGINE

Engine Type	4 Stroke, OHV, Single Cylinder with Forced Air Cooling System
Engine Displacement	149cc
Engine Speed	Eco-Mode: 3000 RPM Non Eco-Mode: 4000 RPM
Fuel Tank Capacity	1.53 Gallons (5.80 L)
Oil Capacity	16.9 fl. oz. (0.5 L)
Half-Load Run Time	Gasoline: 5 Hours
	LPG: 14 Hours (20-lb Tank)
Spark Plug Type	Torch E6RTC (NGK BPR6HS)
Spark Plug Gap	0.023 in. - 0.031 in. (0.6 - 0.8mm)
Spark Plug Torque	11.1 - 14.7 ft-lb (15 - 20 Nm)

# INTRODUCTION

Thanks for purchasing the WEN 3600-Watt Dual Fuel Inverter Generator. Refer to the illustration below for the location of the serial number on the specifications label. Record the generator information in the spaces provided below. If assistance for information or service is required, please contact customer service by calling **1-847-429-9263**, M-F 8-5 CST; you will be asked to provide the following generator information when calling.

**Generator Model Number:** DF360iX

**Date of Purchase:** \_\_\_\_\_

**Purchased From:** \_\_\_\_\_

**Serial Number:** \_\_\_\_\_

Serial Number



**3600-WATT  
PORTABLE INVERTER GENERATOR**

**MODEL DF360iX**

RATED WATTAGE	GAS: 2900W; LPG: 2600W	RATED FREQUENCY	60 Hz
SURGE WATTAGE	GAS: 3600W; LPG: 3500W	RATED VOLTAGE	120V
SERIAL NO.		SPARK PLUG TYPE	E6RTC
ENGINE SERIAL NO.		SPARK PLUG GAP	0.6mm - 0.8mm

**1-847-429-9263 WENPRODUCTS.COM**

Great Lakes Technologies LLC • 1101 Wesemann Drive • West Dundee, IL 60118

**GÉNÉRATEUR  
ONDULEUR**

TYPE 1  
MADE IN VIETNAM

## SERVICE RECORD

Record the service dates of your generator in the chart below. Please perform maintenance checks and operations according to the “Maintenance” section of the manual.

Service Record	Date	Date	Date	Date	Date	Date
Change Oil						
Change Spark Plug						
Clean Fuel Tank						
Clean Air Cleaner						
Clean Spark Arrestor						

**TO MAXIMIZE THE LIFESPAN OF YOUR GENERATOR:** We recommend running your generator at least once a month for 20 to 30 minutes. Start the generator according to the instructions and plug a small load in to make sure the outlet is producing electricity.

# SAFETY INFORMATION

 **WARNING!** Before operating the generator, make sure to read all safety warnings and all instructions. Failure to follow the warnings and instructions may result in electric shock, fire or serious injury.

## SAFETY INTRODUCTION

Safety is a combination of common sense, staying alert, and knowing how your tool works. This manual contains important information regarding the generator's potential safety concerns, as well as preparation, operation, and maintenance instructions. Before operating this generator, be sure to read and observe all warnings and instructions both on the generator labels and in this instruction manual. Failure to follow all instructions listed below may result in personal injury.

**NOTE:** The following safety information is not meant to cover all possible conditions and situations that may occur. WEN reserves the right to change this product and specifications at any time without prior notice.

At WEN, we are continuously improving our products. If you find that your tool does not exactly match this manual, please visit [wenproducts.com](http://wenproducts.com) for the most up-to-date manual or contact customer service at **1-847-429-9263**, M-F 8-5 CST.

**Keep this manual available to all users during the entire life of the tool and review it frequently to maximize safety for both yourself and others.**

## SAVE THESE SAFETY INSTRUCTIONS.

## SAFETY SYMBOLS

The purpose of following safety symbols is to attract your attention to possible dangers. The safety symbols, and their explanations, deserve your careful attention and understanding. The safety warnings do not by themselves eliminate any danger. The instructions or warnings they give are not substitutes for proper accident prevention measures.

 **DANGER:** indicates a hazard, which, if not avoided, will result in death or serious injury.

 **WARNING:** indicates a hazard, which, if not avoided, could result in death or serious injury.

 **CAUTION:** indicates a hazard, which, if not avoided, might result in minor or moderate injury.

**CAUTION!** when used without the alert symbol, indicates a situation that could result in damage to the machine.

## NOTICE REGARDING EMISSIONS

Engines that are certified to comply with U.S. EPA emission regulations for SORE (Small Off Road Equipment), are certified to operate on regular unleaded gasoline, and may include the following emission control systems: (EM) Engine Modifications and (TWC) Three-Way Catalyst (if so equipped).

## QUESTIONS? PROBLEMS?

In order to answer questions and solve problems in the most efficient and speedy manner, contact customer service at **1-847-429-9263**, M-F 8-5 CST or email [techsupport@wenproducts.com](mailto:techsupport@wenproducts.com).

## GENERATOR SAFETY WARNINGS

### **DANGER! CARBON MONOXIDE**

Using a generator indoors **CAN KILL YOU IN MINUTES**. Generator exhaust contains carbon monoxide (CO). This is a poison gas you cannot see or smell. If you can smell the generator exhaust, you are breathing CO. But even if you cannot smell the exhaust, you could be breathing CO.





**NEVER** use a generator inside homes, garages, crawl spaces, or other partially enclosed areas. Deadly levels of carbon monoxide can build up in these areas. Using a fan or opening windows and doors does **NOT** supply enough fresh air. **ONLY** use a generator outside and far away from windows, doors, and vents. These openings can pull in generator exhaust.

Even if you use a generator correctly, CO may leak into the home. **ALWAYS** use a battery-powered or battery-backup CO alarm in the home. If you start to feel sick, dizzy, or weak after the generator has been running, move to fresh air **RIGHT AWAY**. See a doctor. You may have carbon monoxide poisoning.

 **WARNING! RISK OF EXPLOSION. HIGHLY FLAMMABLE:** This generator may emit highly flammable and explosive gasoline vapors, which can cause severe burns or even death, if ignited. A nearby open flame can lead to explosion even if not directly in contact with gasoline.

- Do not operate near open flame, heat, or any other ignition source. Do not smoke near the generator.
- Always operate on a firm, level surface.
- Always turn generator off before refueling. Allow generator to cool for at least 2 minutes before removing fuel cap. Loosen cap slowly to relieve pressure in tank.
- Do not overfill fuel tank. Gasoline may expand during operation. Do not fill to the top of the tank. Allow for expansion. Always check for spilled fuel before operating.
- If fuel spills, move the generator at least 30 feet away from the spill and wipe clean any spilled fuel before starting the engine.
- Empty fuel tank before storing or transporting the generator.

 **WARNING!** If this generator is used as a supply for a building's wiring system, the generator must be installed by a qualified electrician and connected to a transfer switch as a separately derived system in accordance with all applicable laws and electrical codes and the National Electrical Code, NFPA 70. The generator shall be connected to a transfer switch that switches all conductors excluding the equipment grounding conductor. The frame of the generator shall be connected to an approved grounding electrode.

 **WARNING!** This product can expose you to chemicals including carbon monoxide and engine exhaust, which are known to the State of California to cause cancer and birth defects or other reproductive harm. For more information, go to [www.P65Warnings.ca.gov](http://www.P65Warnings.ca.gov).

# GENERATOR SAFETY WARNINGS

 **WARNING!** Do not let comfort or familiarity with the product replace strict adherence to product safety rules. Failure to follow the safety instructions may result in serious personal injury.

## OPERATING ENVIRONMENT

**1. Using a generator indoors can kill you in minutes.** Only use a generator outside and far away from windows, doors and vents.

**2. Do not smoke near the generator.**

**3. Do not operate near open flame, heat, or flammable materials.** This generator may emit highly flammable and explosive gasoline vapors, which can cause severe burns or even death if ignited. A nearby open flame can lead to an explosion even if it isn't directly in contact with gasoline.

**4. Do not expose the generator to rainy or wet conditions; doing so significantly increases the risk of electrical shock.** Never handle the generator, electronic devices, or any cord while standing in water, while barefoot, or when hands or feet are wet.

**5. Always operate the generator on a dry, firm, level surface.**

**6. The generator should have at least 5 feet of clearance from buildings or other equipment during operation.**

**7. Do not allow children or non-qualified persons to operate the generator.**

## GENERATOR PREPARATION

**1. Always ground the generator before using it to maximize safety** (see "Ground the Generator" section).

**2. Do not overfill fuel tank, as gasoline may expand during operation.** Do not fill to the very top of the tank. Leave room for gasoline expansion. Always check for spilled fuel before operating.

**3. If any part of the generator, electrical device or power cord is broken, damaged, or defective, make sure it is repaired or replaced before operation.** Service should only be performed by a qualified technician. Do not use receptacles or cords that show signs of damage, such as broken or cracked insulation.

**4. Use a ground fault circuit interrupter (GFCI) in highly conductive areas such as metal decking or steel work.** Extension cords with in-line GFCIs are recommended for these operations to maximize safety.

**5. If connecting the generator to a building's electrical system for standby power, you MUST consult a qualified electrician and install a transfer switch.** Such connections must comply with local electrical laws and codes. Failure to comply can create a back-feed, which may result in serious injury or death to utility workers.

**6. Never modify the generator in any way.** Modifying or using the machine for any other purpose for which it is not designed may result in serious injuries, machine damage and voiding of the warranty.

## GENERATOR OPERATION

**1. Only use the generator for its intended purposes.** Modifying or using the generator for operations for which it was not designed may cause hazards and personal injury.

**2. Do not touch bare wires or receptacles (outlets).**

**3. Do not exceed the wattage capacity of the generator by plugging in more electrical devices than the unit can handle.** This could damage the generator and/or connected electrical devices. Check the operating voltage and frequency requirements of all electrical devices prior to plugging them into the generator.

**Generator safety warnings continue on the next page.**

## GENERATOR SAFETY WARNINGS

**⚠ WARNING!** Do not let comfort or familiarity with the product replace strict adherence to product safety rules. Failure to follow the safety instructions may result in serious personal injury.

**TO MAXIMIZE THE LIFESPAN OF YOUR GENERATOR:** We recommend running your generator at least once a month for 20 to 30 minutes. Start the generator according to the instructions and plug a small load in to make sure the outlet is producing electricity. If you do not run it often, it will greatly shorten the generator's lifespan and void the warranty.

4. **Allow generator to run for several minutes before connecting electrical devices.** Do not start or stop engine with electrical devices plugged in to the receptacles. Failure to do so could damage the generator and/or connected electrical devices.
5. **Do not turn on electrical devices until after they are connected to the generator.**
6. **Generators vibrate in normal use.** During and after the use of the generator, inspect both the generator as well as extension and power supply cords for damage resulting from vibration.
7. **Do not touch hot parts.** This generator produces heat when running. Temperatures near exhaust can exceed 150°F (65°C). Allow generator to cool down after use before touching engine or areas of the generator that become hot during use.
8. **Turn off all connected electrical devices before stopping the generator.**
9. **Always turn generator off before refueling.** Allow generator to cool for at least 2 minutes before removing fuel cap. Loosen cap slowly to relieve pressure in tank.
10. **Turn the engine switch to “OFF” position when the engine is not running.**
11. **Empty fuel tank before storing or transporting the generator.** Do not store generator or gasoline near furnaces, water heaters, or any other appliances that produce heat or have automatic ignitions. Store the generator and fuel away from sparks, open flames, pilot lights, heat and other sources of ignition.
12. **Always wash hands after handling generator.**

**CAUTION:** Misuse of this generator can damage it or shorten its lifespan.



# UNPACKING & PACKING LIST

## UNPACKING

With the help of a friend or trustworthy foe, such as one of your in-laws, carefully remove the generator from the packaging and place it on a sturdy, flat surface. Make sure to take out all contents and accessories. Do not discard the packaging until everything is removed. Check the packing list below to make sure you have all of the parts and accessories. If any part is missing or broken, please contact customer service at **1-847-429-9263** (M-F 8-5 CST), or email [techsupport@wenproducts.com](mailto:techsupport@wenproducts.com).

## PACKING LIST

### Components

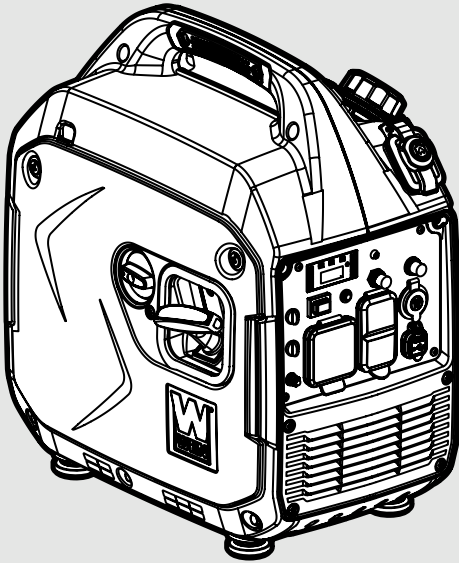

Generator

### Tools & Accessories



8/10mm Wrench

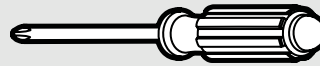

Screwdriver

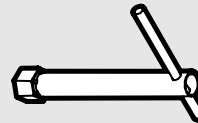

Spark Plug Socket

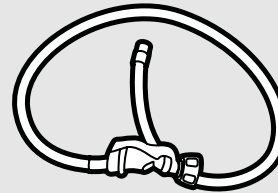

LPG Regulator Hose

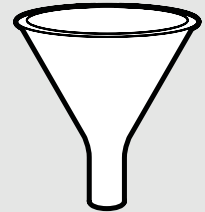

Funnel

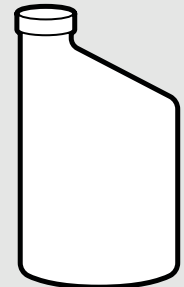

Engine Oil (0.50 L)

# KNOW YOUR INVERTER GENERATOR

## TOOL PURPOSE

Inverter Generators provide you with clean and quiet power, when and where you need it most. Refer to the following diagrams to become familiarized with all the parts and controls of your Generator. The components will be referred to later in the manual for assembly and operation instructions.

## GENERATOR

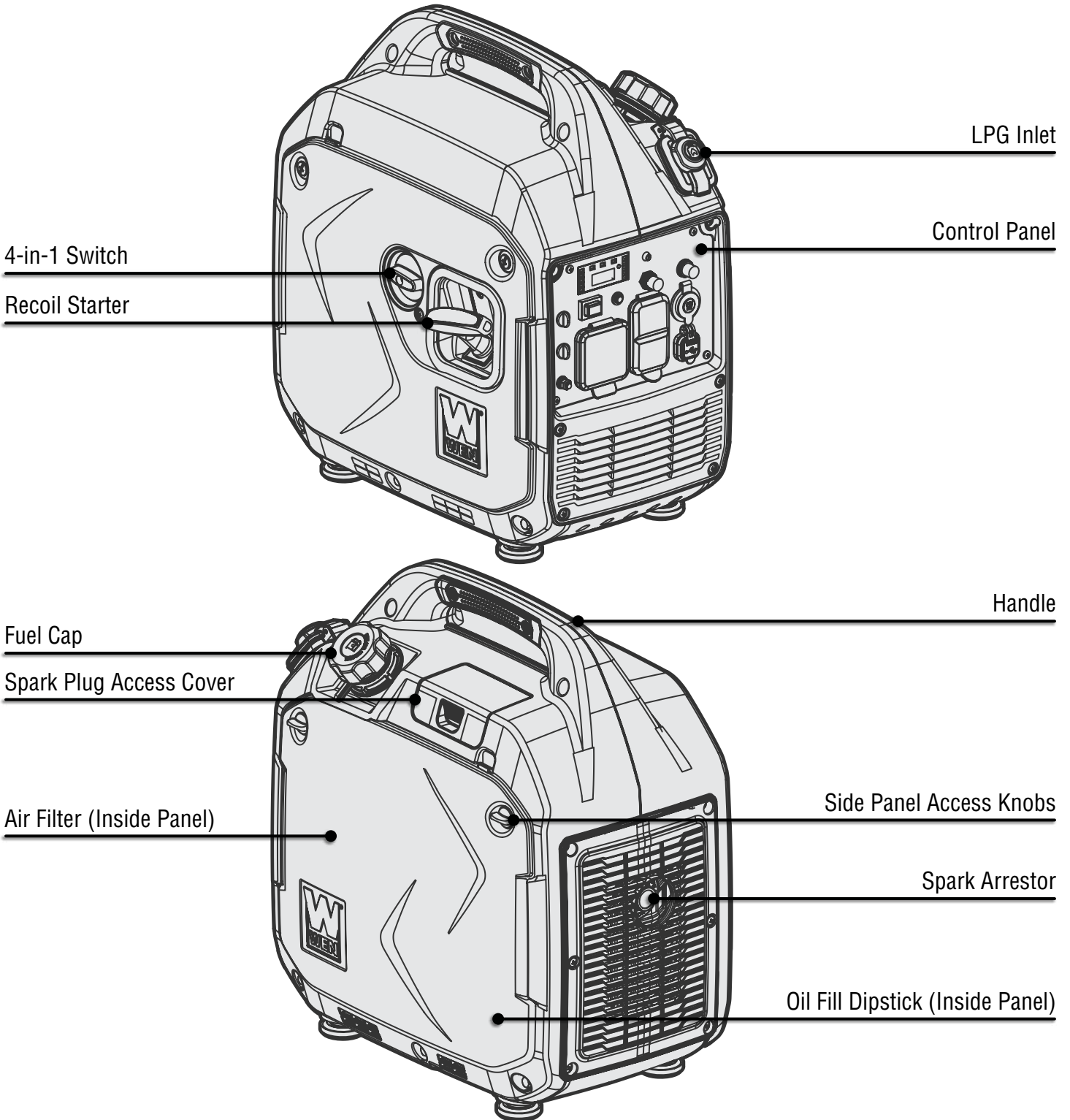

# KNOW YOUR INVERTER GENERATOR

## CONTROL PANEL

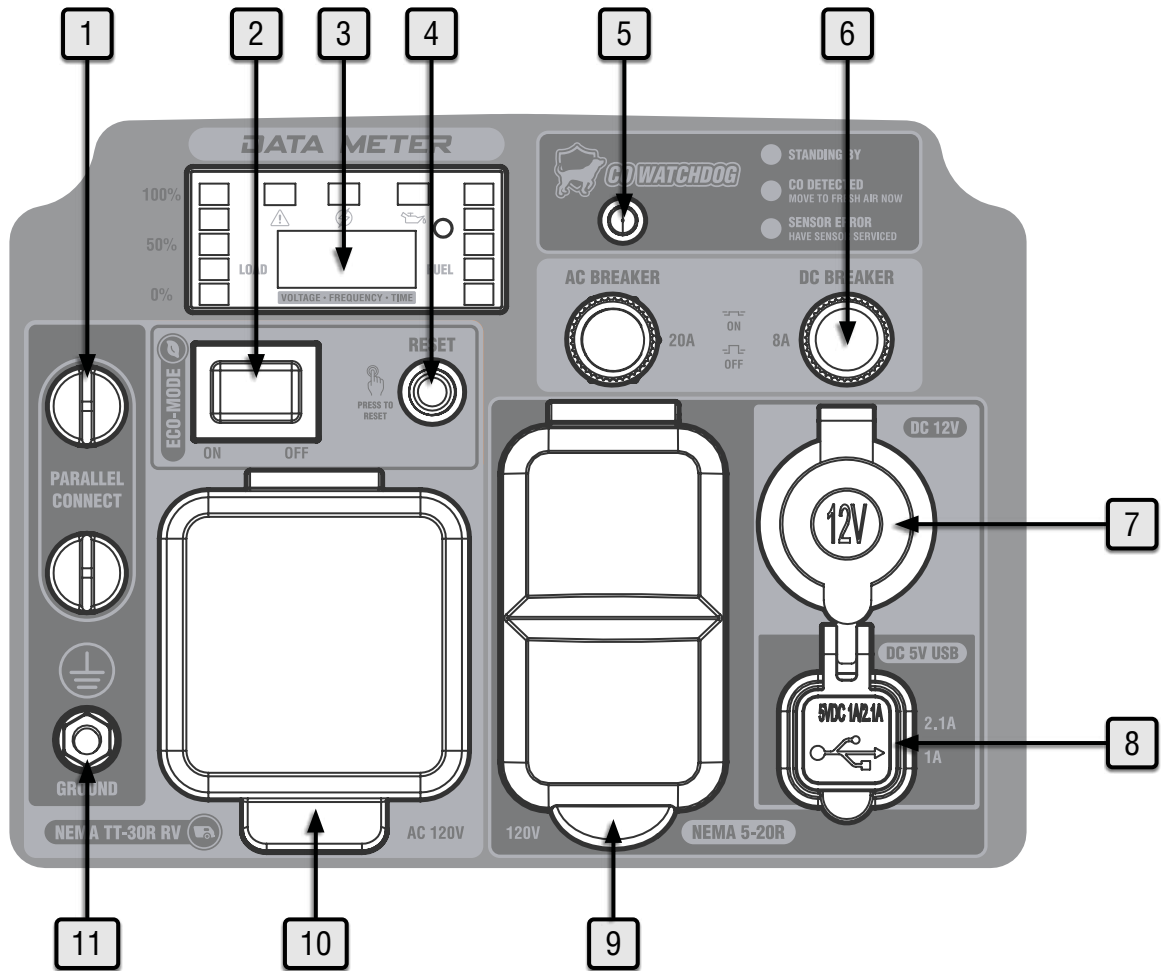

### 1. Parallel Connection

Connect to share wattage between inverter generators.

### 2. Eco-Mode Switch

Maximizes fuel economy & run time.

### 3. Data Meter with Indicator Light

Displays load level (left), fuel level (right), voltage (e.g. V120), frequency (e.g. F60.0), session runtime (e.g. A 0.0), and total runtime (e.g. 0.0). Press MODE to switch between displays.

### 4. Reset Button

Press to reset the circuit in case of overload.

### 5. CO WATCHDOG Carbon Monoxide Monitor

Measures the accumulation of poisonous CO gas while the generator is running. If the level of CO gas gets too high, the CO Watchdog system will automatically shut down the generator. See p. 25 for more information.

### 6. DC Circuit Breaker

Press to reset.

### 7. 12V DC Outlet

Cigarette-style outlet provides DC power.

### 8. 5V USB Port

1A & 2.1A for charging various electronic devices.

### 9. AC 120V NEMA 5-20R Duplex Receptacles

Standard household outlets provide 120V 60Hz power.

### 10. AC 120V NEMA TT-30R RV Receptacle

Standard RV connector.

### 11. Grounding Nut

Ground the generator to reduce the risk of electric shock.

# PREPARATION

The following section describes the necessary steps to prepare the generator for use. If you are unsure about how to perform any of the steps please call **1-847-429-9263** M-F 8-5 CST for customer service. Failure to perform these steps properly can damage the generator or shorten its life.

## STEP 1 - ADD / CHECK OIL

The generator is shipped without oil. User must add the proper amount of oil before operating the generator for the first time. The oil capacity of the engine crankcase is **16.9 fl. oz (0.5 L)**.

### ENGINE OIL RECOMMENDATIONS

Select good quality detergent oil bearing the American Petroleum Institute (API) service classifications SJ, SL, or SM (synthetic oils may be used). Select the SAE viscosity grade of oil that matches the expected operating temperature.

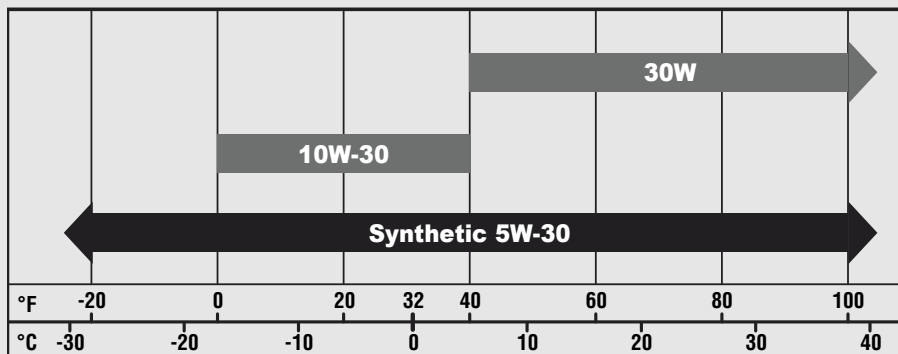

Fig. 1

- **30W Engine Oil**  
Temperatures above 40°F
- **10W-30 Engine Oil**  
Temperatures between 0°F - 40°F
- **Synthetic 5W-30 Engine Oil**  
All temperature ranges

### TO ADD OIL:

1. Place the generator on a level surface. Make sure the engine is OFF before adding or checking oil.

**CAUTION!** Keep the generator level. Tilting the generator to assist in filling will cause oil to flow into the wrong areas of the engine and cause damage.

1. Open the side panel (to the right of the control panel) by twisting the side panel access knobs (Fig. 2 - 1). Remove and wipe the oil dipstick with a clean rag. Insert the dipstick into the oil fill opening without screwing it in.

2. Remove the dipstick to check the oil mark on the dipstick (Fig. 3). Add oil if the oil mark covers less than one half of the dipstick.

3. Slowly add oil and repeat step 2 until the oil mark measures between the upper limit mark and halfway mark of the dipstick. Do not overfill the crankcase.

4. Wipe clean any oil leaks and firmly tighten the dipstick.

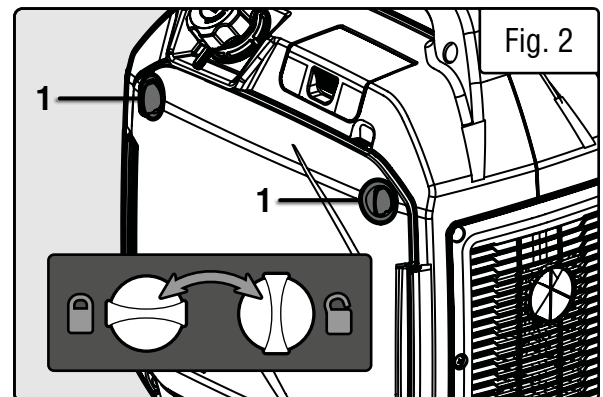

Fig. 2

**CAUTION!** For subsequent operation, the oil level should be checked before each use, or after every 8 hours of operation. The generator is equipped with a low-oil sensor and will not start without a sufficient amount of oil. Follow the instructions on the next page to check the oil level.

## PREPARATION

### TO CHECK OIL LEVEL (before every subsequent start):

1. Place the generator on a level surface. Make sure the engine is OFF before adding or checking oil.
2. Remove and wipe the dipstick with a clean rag.
3. Insert the dipstick into the oil fill without screwing it in. Remove the dipstick to check the oil mark.
4. If the oil mark covers **less than one half** of the dipstick, slowly **add oil** until the oil mark measures between the upper limit mark and halfway mark of the dipstick. See Fig. 3.

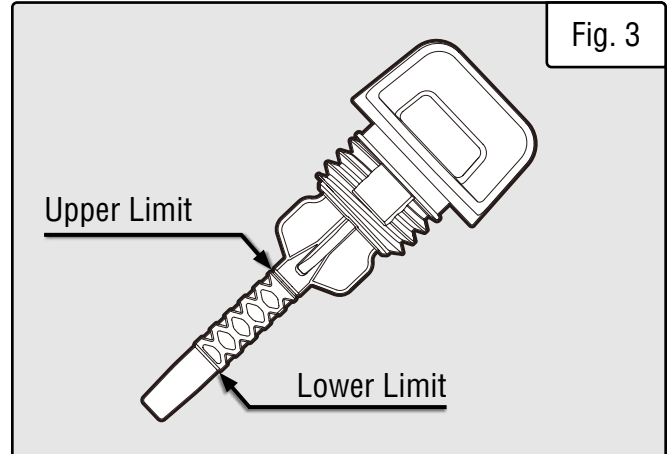

**TIP:** Your WEN generator is compatible with the **WEN 55201** Magnetic Oil Dipstick (not included), available for purchase at [wenproducts.com](http://wenproducts.com). The dipstick's industrial-strength magnetic tip will collect metal shavings from your generator's oil tank to help preserve the engine and extend your generator's lifespan.

# PREPARATION

## STEP 2 - ADD / CHECK FUEL

### FUEL OPTION A: GASOLINE

**⚠ WARNING! RISK OF EXPLOSION. HIGHLY FLAMMABLE:** This generator may emit highly flammable and explosive gasoline vapors, which can cause severe burns or even death, if ignited. A nearby open flame can lead to explosion even if not directly in contact with gasoline.

- Do not operate near open flame, heat, or any other ignition source. Do not smoke near the generator.
- Always operate on a firm, level surface.
- Always turn generator off before refueling. Allow generator to cool for at least 2 minutes before removing fuel cap. Loosen cap slowly to relieve pressure in tank.
- Do not overfill fuel tank. Gasoline may expand during operation. Do not fill to the top of the tank. Allow for expansion. Always check for spilled fuel before operating.
- If fuel spills, move the generator at least 30 feet away from the spill and wipe clean any spilled fuel before starting the engine.
- Empty fuel tank before storing or transporting the generator.

**ONLY** use fresh (within 30 days from purchase), lead-free gasoline with a **minimum of 87 octane rating**. The generator performs best with ethanol-free gasoline. **DO NOT** use gasoline with over 10% ethanol.

The capacity of the fuel tank is **1.53 gallons (5.8 L)**. Do not mix oil with gasoline.

#### TO ADD GASOLINE:

Use fresh (within 30 days from purchase), lead-free gasoline with a minimum of 87 octane rating. The generator performs best with ethanol-free gasoline. **DO NOT** use gasoline with over 10% ethanol. The capacity of the fuel tank is 1.53 gallons. Do not mix oil with gasoline.

1. Place the generator on a level surface. Make sure the engine is off before adding or checking the fuel.
2. Unscrew the fuel cap (Fig. 4 - 1) and set it aside. The fuel cap may be tight and hard to unscrew.
3. Slowly add unleaded gasoline to the fuel tank. Be careful not to overfill. Reinstall fuel cap and wipe clean any spilled gasoline with a dry cloth.

**NOTE:** Do not fill the fuel tank to the very top. If you do so, gasoline will expand and spill during use, even with the fuel cap in place.

4. Reinstall fuel cap and wipe clean any spilled gasoline with a dry cloth.

#### IMPORTANT:

- Avoid getting dirt or water into the fuel tank.
- Keep gasoline away from sparks, open flames, pilot lights, heat, and other sources of ignition.
- Gasoline can age in the tank and make starting difficult. Never store the generator for more than 2 months with fuel in the tank.
- Never use an oil/gasoline mixture.
- Never use old gasoline.

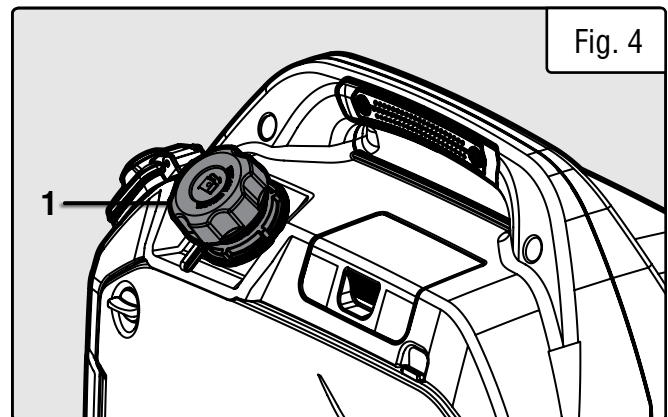

## PREPARATION

### FUEL OPTION B: LIQUID PETROLEUM GAS (LPG)

#### To connect your generator to an LPG cylinder:

1. Take off the safety caps from the cylinder valve, generator mounted regulator, and regulator connecting hose ends.
2. With the LPG tank valve closed, attach the LPG regulator connecting hose (Fig. 5 - 1) to the valve. Turn the plastic coupling from the hose right (clockwise) to tighten hose assembly onto the LPG tank.
3. Remove the protective cover from the LPG inlet (Fig. 6 - 1) on the generator. Push the connector on the other end of the regulator hose into the LPG inlet until it clicks into place.
4. Turn the LPG tank valve ON and check for leaks by spraying soapy water to check connections. If bubbles appear, become larger in size, or increase in number, a leak exists. This **MUST** be corrected before using generator. Contact WEN customer service at **1-847-429-9263**, M-F 8-5 CST, or email [techsupport@wenproducts.com](mailto:techsupport@wenproducts.com) for assistance.

**NOTE:** If you would like to purchase other accessories for your dual-fuel generator, consult your local dealer of propane and propane accessories, I tell you what.

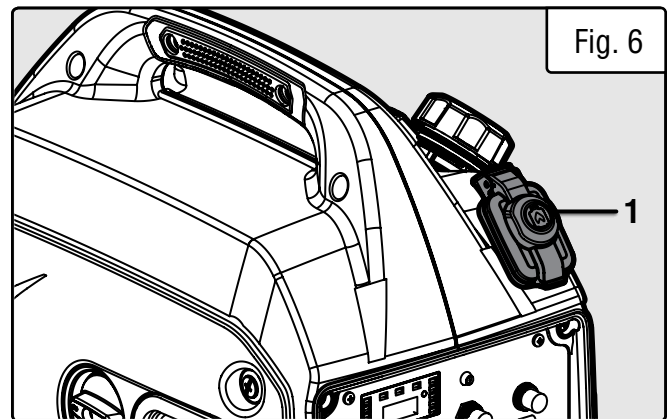
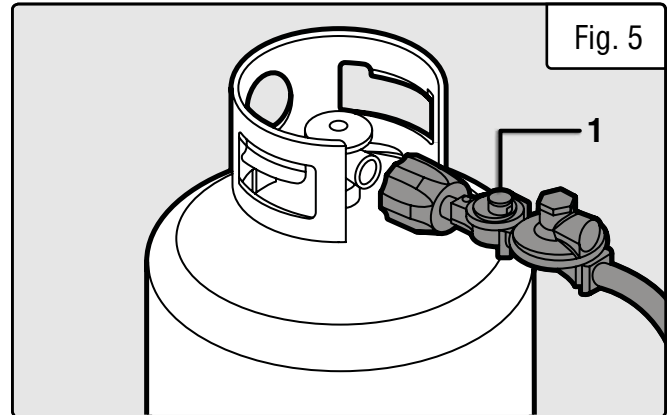

**CAUTION!** Always position the LPG cylinder so the connection between the tank and LPG inlet won't cause sharp bends or kinks in the hose.

**WARNING!** Risk of burns. Contact with liquid contents of cylinder will cause freeze burns to the skin. If liquid contents contacts skin or eyes, seek immediate medical attention.

**WARNING!** When transporting and storing, keep cylinder secured in an upright position with cylinder valve turned off. Keep cylinders ventilated and away from heat when in a vehicle.

# PREPARATION

## AUTO FUEL SELECTION

Your generator is equipped with Auto Fuel Selection Technology. What this means is that the generator will automatically select the fuel source (LPG or gasoline) depending on availability. LPG is prioritized; this means that if a propane tank with enough LPG is connected, the generator will automatically use LPG. If no propane tank is connected, the generator will use gasoline (if there is gasoline in the fuel tank). The LPG regulator hose must be disconnected for the generator to switch to gasoline. If the LPG regulator hose is connected and you run out of LPG, the generator will not automatically switch to gasoline.

**NOTE:** Make sure the generator can handle the load(s) you plan to connect. The generator can provide more power when running on gasoline than on LPG. Consult the specifications table on p. 3, as well as the “Calculating the Wattage of Your Device(s)” chart to ensure that your load(s) will not exceed the rated wattage for a particular fuel. See also the “Switching Fuels” section for more information.

## STEP 3 - GROUND THE GENERATOR

To reduce the risk of electric shock and to maximize safety, the generator should be properly grounded.

1. Attach one end of the grounding wire to the grounding nut (Fig. 7 - 1). Tighten the nut to secure the grounding wire.
2. Connect the other end of the grounding wire to a copper, brass, or steel-grounding rod that is driven into the earth.

## HIGH ALTITUDE OPERATION ABOVE 2000 FEET

The fuel system on this generator may be affected by operation at high altitudes. Proper operation can be ensured by installing an altitude kit at altitudes higher than 3000 feet above sea level. At elevations above 9800 feet, the engine may experience a decrease in performance, even with the proper altitude kit. Operating this generator without said kit may increase the engine’s emissions and decrease both fuel economy and performance.

This kit should be installed by a qualified mechanic. You can order the kit at [wenproducts.com](http://wenproducts.com) by searching part number **DF360iX-HA39**. Refer to the instructions included with your altitude kit for more information about installation.

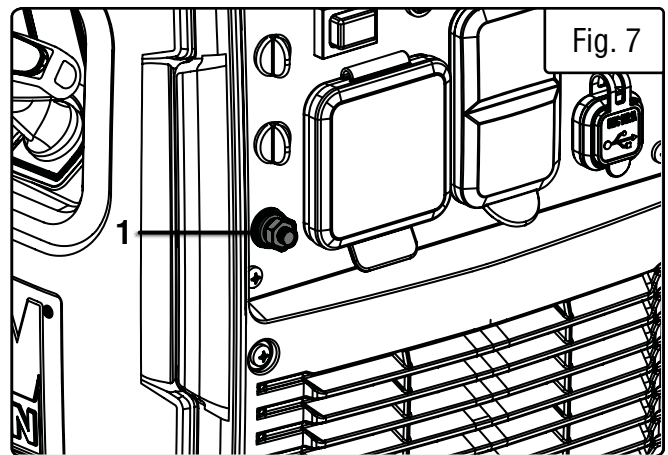

**WARNING!** Failure to properly ground the generator increases your risk of electric shock.

**NOTE:** Grounding wire and grounding rods are not included with the generator. A generally acceptable grounding wire is a **No. 12 AWG (American Wire Gauge) stranded copper wire**. Grounding codes can vary by location. Contact a local electrician to check the area codes.

**WARNING!** To prevent serious injury from fire, follow the kit installation procedures in a well-ventilated area away from ignition sources. If the engine is hot from use, shut the engine off and wait for it to cool before proceeding. Do not smoke near the generator. Warranty will be void if adjustments are not made for high altitude use.

**CAUTION!** UNINSTALL the high altitude kit when operating at altitudes below 2000 feet.



## STARTING YOUR GENERATOR

Before starting the generator, make sure you have read and performed the steps in the “Preparation” section of this manual, pages 12-14. If you are unsure about how to perform any of the steps in this manual please call **1-847-429-9263** M-F 8-5 CST for customer service.

### **DANGER! CARBON MONOXIDE**

Using a generator indoors **CAN KILL YOU IN MINUTES**. Generator exhaust contains carbon monoxide (CO). This is a poison gas you cannot see or smell. If you can smell the generator exhaust, you are breathing CO. But even if you cannot smell the exhaust, you could be breathing CO.

**NEVER** use a generator inside homes, garages, crawl spaces, or other partially enclosed areas. Deadly levels of carbon monoxide can build up in these areas. Using a fan or opening windows and doors does NOT supply enough fresh air. **ONLY** use a generator outside and far away from windows, doors, and vents. These openings can pull in generator exhaust.

Even if you use a generator correctly, CO may leak into the home. **ALWAYS** use a battery-powered or battery-backup CO alarm in the home. If you start to feel sick, dizzy, or weak after the generator has been running, move to fresh air **RIGHT AWAY**. See a doctor. You may have carbon monoxide poisoning.

 **WARNING!** The exhaust from this product contains chemicals known to the State of California to cause cancer, birth defects, or other reproductive harm.

 **WARNING!** Do not operate generator near open flame or flammable materials. This generator may emit highly flammable and explosive gasoline vapors, which can cause severe burns or even death if ignited. A nearby open flame can lead to explosion even if it isn't directly in contact with gasoline. Do not smoke near the generator.

 **WARNING!** This generator produces powerful voltage, which can result in electrocution.

 **WARNING!** Do not use in rainy or wet conditions. Do not touch bare wires or receptacles (outlets). Do not allow children or non-qualified persons to operate.

 **WARNING!** Generator should only be connected to electrical devices, either directly or with an extension cord. **NEVER** connect to a building electrical system without a qualified electrician and connected to a transfer switch as a separately derived system. Such connections must comply with local electrical laws and codes. Failure to comply can create a back-feed, which may result in serious injury or death to utility workers.

To maximize safety, **ALWAYS** ground the generator before using it. See page 16, “GROUND THE GENERATOR”.

Use a ground fault circuit interrupter (GFCI) in highly conductive areas such as metal decking or steel work. GFCIs are available in-line with some extension cords.

**CAUTION!** Disconnect all electrical loads from the generator before attempting to start.

**Follow the instructions on the next page to start your generator.**

# STARTING YOUR GENERATOR

## BEFORE STARTING THE GENERATOR

1. Verify that the generator is outside on a dry, level surface. Allow at least two feet of clearance on all sides of the generator.
2. To maximize safety, check that the generator is properly grounded. See page 16, “GROUND THE GENERATOR.”
3. Check that there is a sufficient level of oil in the crankcase. Add oil if necessary. Refer to page 12, “STEP 1 - ADD / CHECK OIL.”
4. If using gasoline, make sure there is enough gasoline in the fuel tank. Add fuel if necessary (see “ADD / CHECK FUEL”). If using LPG, make sure there is enough propane in the tank, and that the tank and regulator hose are properly connected.
5. Make sure all electrical devices are unplugged from the generator during ignition. Otherwise it will be difficult for the engine to start.

## STARTING THE GENERATOR (GASOLINE)

1. Place the generator outside on a dry, level surface. Allow at least two feet of clearance on all sides of the generator.
2. Check there is sufficient level of oil in the crankcase. Add oil if necessary (refer to “ADD / CHECK OIL” on page 12).
3. Check there is sufficient level of gasoline in the fuel tank. Add fuel if necessary (refer to “ADD GASOLINE” on page 14).
4. To maximize safety, make sure the generator is properly grounded (refer to “GROUND THE GENERATOR” on page 16).
5. Make sure all electrical devices are unplugged from the generator during ignition. Otherwise it will be difficult for the engine to start.
6. Turn the ECO-MODE switch to “OFF” during starting (Fig. 8 - 1).
7. Turn the 4-in-1 switch (Fig. 9 - 1) to the “CHOKE” position.
8. Pull on the recoil starter handle (Fig. 10) slowly until a slight resistance is felt, then pull quickly to start the engine. Return cord gently into the recoil starter. Never allow the cord to snap back.
9. Turn the 4-in-1 switch (Fig. 9 - 1) to the “RUN” position.
10. Allow the engine to run for several minutes before attempting to connect any electrical devices. This allows the generator to stabilize its speed and temperature.

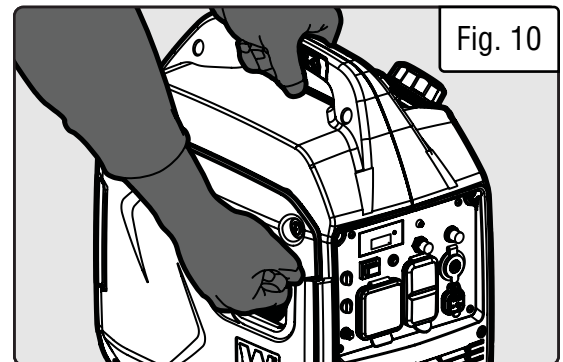
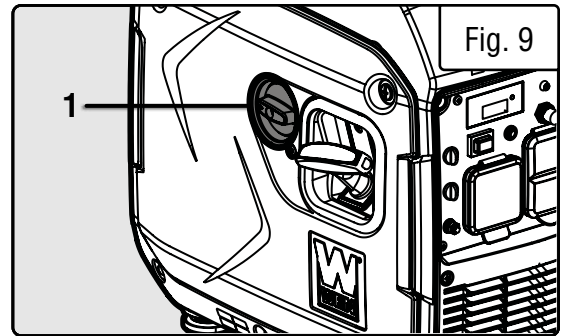
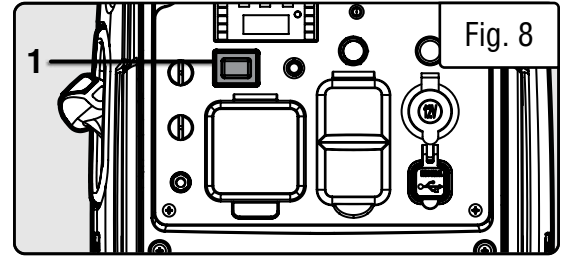

## ***STARTING YOUR GENERATOR***

### **STARTING THE GENERATOR (LPG)**

1. Place the generator outside on a dry, level surface. Allow at least two feet of clearance on all sides of the generator.
2. Check there is sufficient level of oil in the crankcase. Add oil if necessary (refer to “ADD / CHECK OIL” on page 12).
3. Make sure that the LPG regulator hose is properly connected to the LPG tank and the inlet on the generator (refer to “FUEL OPTION B: LIQUID PETROLEUM GAS (LPG)” on page 15).
4. To maximize safety, make sure the generator is properly grounded (refer to “GROUND THE GENERATOR” on page 16).
5. Make sure all electrical devices are unplugged from the generator during ignition. Otherwise it will be difficult for the engine to start.
6. Turn the ECO-MODE switch to “OFF” during starting (Fig. 8 - 1).
7. Turn the 4-in-1 switch (Fig. 9 - 1) to the “CHOKE” position.
8. Gently pull the recoil starter handle (Fig. 10) 3 - 5 times to prime the engine.
9. Turn the 4-in-1 switch (Fig. 9 - 1) to the “RUN” position.
10. Quickly pull the recoil starter handle to start the engine. Return the cord gently into the recoil starter. Never allow the cord to snap back.
11. Allow the engine to run for several minutes before attempting to connect any electrical devices. This allows the generator to stabilize its speed and temperature.

# STARTING YOUR GENERATOR

## ECO-MODE SWITCH

This generator is equipped with an Eco-Mode Idle Control Switch (Fig. 8 - 1). Engaging the switch automatically adjusts the engine to match the load. When the electrical load changes, the generator engine will automatically speed up and slow down as needed. This reduces fuel consumption and noise levels.

Keep this switch engaged when the power load requirement is less than 2000W. Do not engage the Eco-Mode Switch when the total load is more than 2000W. The generator engine must run at full speed to supply power for anything over 2000W.

## OIL LEVEL SHUTDOWN

The low oil indication light on the data meter (Fig. 11 - 1) will turn on to remind you that the engine oil level is low and need to be refilled. The generator is equipped with a low oil pressure shutoff that will automatically stop the engine when the oil level is too low to protect the unit from damage. The oil level of the engine should be checked before each start to ensure that the engine crankcase contains sufficient lubricant.

## PARALLEL OPERATION

The parallel connection feature (Fig. 12 - 1) allows you to connect two WEN generators to increase the total available electrical power. The “Parallel Connection Kit” can be purchased from [wenproducts.com](http://wenproducts.com).

Follow the instructions included with your WEN parallel connection kit for proper installation and operation.

## ENGINE BREAK-IN PROCEDURE

The procedure below should be followed when you receive your generator in order to prolong the engine’s service life. This procedure helps to seat the piston rings properly in the cylinder, and will reduce overall wear on the engine.

For the first 8 hours of operation, vary the load, but keep it at or below 50% of the generator’s rated wattage, if possible. If your generator is equipped with an Eco-mode switch (only applicable for certain inverter generators), engage Eco-mode periodically during the first 8 hours. After the first 8 hours, change the oil, then change it again after the first 25 hours. You may run the generator at full load after the 8-hour oil change. Refer to the Recommended Maintenance Schedule in Table 4 for the full maintenance schedule.

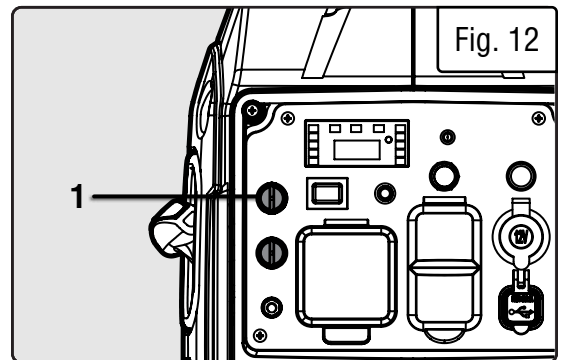
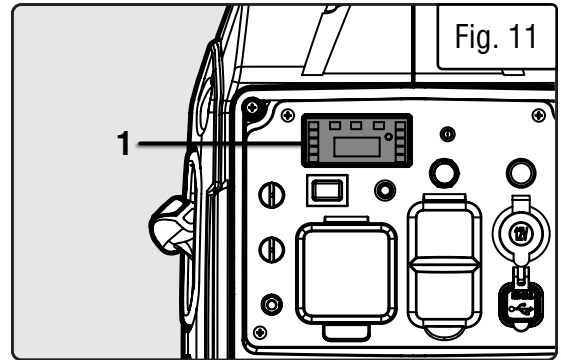

## USING YOUR GENERATOR

### CALCULATING THE WATTAGE OF YOUR DEVICE(S)

Connect electrical devices running on AC current according to their wattage requirements. Calculate the total running wattage and starting wattage of the device(s) you wish to connect, and **MAKE SURE** that they are within the capacity of your generator and the capacity of each individual outlet.

Generator Wattage Capacity	GENERATOR RUNNING (RATED) WATTS	GENERATOR STARTING (SURGE) WATTS
	<b>Gasoline: 2900W</b>	<b>Gasoline: 3600W</b>
	<b>LPG: 2600W</b>	<b>LPG: 3500W</b>
Generator Wattage Capacity	<p><b>What this means:</b> The generator can produce a maximum of 2900W / 2600W on a continuous basis to supply ongoing power to your electronic devices.</p> <p><b>NOTE:</b> Also check the rated amperage for each outlet and make sure not to overload the individual outlets.</p>	<p><b>What this means:</b> Some devices such as box fans require short bursts of extra power in addition to the rated wattage listed by the device to start their motors.</p> <p>The generator can produce a maximum wattage of 3600W / 3500W for a short period of time (seconds) to cover the extra starting power required by your electronic devices.</p>
Electronic Device Wattage Calculation	<p>Find the wattage information of each device you plan to connect. The information should be listed on the device or in its instruction manual, or you may refer to page 22, Table 2.</p> <p style="text-align: center;">The wattage can be calculated using this equation: <b>Watts = Volts x Amperes</b></p>	
Electronic Device Wattage Calculation	<p><b>To calculate the total running watts of your devices:</b></p> <p>+ Add up the running wattages of all the device(s) you plan to connect.</p> <p>= The total running (rated) wattage.</p> <p>This wattage should NOT exceed the running wattage of <b>2900W / 2600W</b>.</p> <p>It is recommended to maintain a load at or below 2610W / 2340W (90% of the rated output) to ensure steady voltage output and to prolong the generator's lifespan.</p>	<p><b>To calculate the total starting watts of your devices:</b></p> <p>+ Add up the total running wattage of all the device(s) you plan to connect.</p> <p>+ Add the single highest <b>ADDITIONAL</b> starting wattage out of the device(s) you plan to connect.</p> <p>= The total starting (surge) wattage.</p> <p>This wattage should NOT exceed the starting wattage of 3600W / 3500W.</p>
Electronic Device Wattage Calculation	<p>If any of either of the total calculated running watts or starting watts is higher than the capacity of your generator, adjust the load until both wattage requirements are met. Otherwise you will overload the generator, and cause damage to the engine and your electrical device(s).</p>	

Table 1 - How to Calculate Wattages

## **USING YOUR GENERATOR**

### **CALCULATING THE WATTAGE OF YOUR DEVICE(S) - CONTINUED**

The chart below serves as a reference for the estimated wattage requirements of common electrical devices. However, do not solely rely on this chart - all electronics and appliances are built differently. Always check the wattage listed on the electrical device before consulting this chart.

<b>Tool or Appliance</b>	<b>Rated (Running) Watts</b>	<b>Surge (Starting) Watts</b>
Electric Water Heater (40 Gal)	4000	0
Hot Plate	2500	0
Saw - Radial Arm	2000	2000
Electric Stove (Each Element)	1500-2800	0
Saw - Circular	1500	1500
Air Compressor (1 HP)	1500	3000
Window Air Conditioner	1200	1800
Saw - Miter	1200	1200
Microwave	1000	0
Well Water Pump	1000	1000
Sump Pump	800	1200
Refrigerator Freezer	800	1200
Furnace Blower	800	1300
Computer	800	0
Electric Drill	600	900
Television	500	0
Deep Freezer	500	500
Garage Door Opener	480	0
Stereo	400	0
Box Fan	300	600
Clock Radio	300	0
Security System	180	0
Dvd Player / VCR	100	0
Common Light Bulb	75	0

Table 2 - Estimated Wattages of Common Electrical Appliances

**NOTE:** Become familiar with the functions and capacity of each component on the control panel before connecting electrical devices. See page 11 for more information about the components of the control panel. Do not overload generator or individual panel receptacles. Do not connect 50Hz or 3-phase loads to the generator.

# USING YOUR GENERATOR

## CONNECTING ELECTRICAL DEVICES

When the rated wattage requirement of each electrical device has been determined, add these numbers to find the total rated wattage needed. If this number exceeds the rated wattage (2900W) of the generator, DO NOT connect all these devices. Select a combination of electrical devices with a total rated wattage lower than or equal to the rated wattage of the generator.

**⚠ CAUTION!** Become familiar with the markings on the control panel (Fig. 13) before connecting electrical devices. Do not connect 50 Hz loads to the generator.

1. Before connecting electrical devices, allow the generator to run for a few minutes to stabilize the speed and voltage output.
2. Make sure that all devices are turned off. Start plugging in each electric device, from the highest wattage to the lowest. Check the power indicator light (green) to ensure the generator is producing power.
3. Do not overload the generator or individual panel receptacles. If an overload occurs, the overload indication light (red) will activate. If it is flashing, turn off and unplug one load. If it is solid (not flashing), the generator will cut off power to protect itself. Unplug all electrical devices and then press the reset button to reset the entire circuit, or press the circuit breaker to reset the DC circuit. Check the total wattage of the devices and reduce the load if it exceeds the capacity of the generator. Then, plug the loads back in one by one.

**NOTE:** If the reset button or circuit breaker does not reset, wait several minutes and try again. If problem still persists, please call **1-847-429-9263** M-F 8-5 CST.

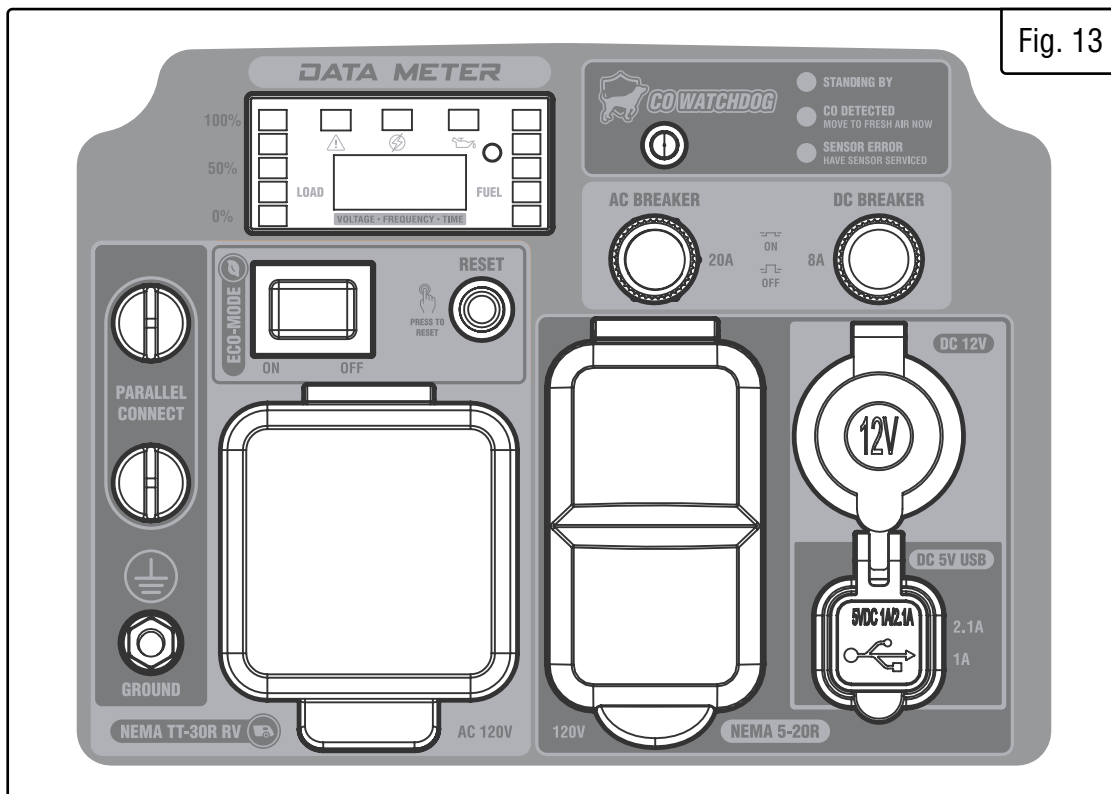

## **USING YOUR GENERATOR**

### **SOME NOTES ABOUT POWER CORDS**

Long or thin cords can drain the power provided to an electrical device by the generator. When using such cords, allow for a slightly higher rated wattage requirement by the electrical device.

Device Requirements			Max. Cord Length (ft) by Wire Gauge				
Amps	Watts (120V)	Watts (240V)	#8 wire	#10 wire	#12 wire	#14 wire	#16 wire
2.5	300	600	NR	NR	NR	375	250
5	600	1200	NR	NR	300	200	125
7.5	900	1800	NR	350	200	125	100
10	1200	2400	NR	250	150	100	50
15	1800	3600	NR	150	100	65	NR
20	2400	4800	175	125	75	50	NR
25	3000	6000	150	100	60	NR	NR
30	3600	7200	125	65	NR	NR	NR
40	4800	9600	90	NR	NR	NR	NR

\*NR = Not Recommended

Table 3 - Power Cord Requirement Guide

**⚠ WARNING!** Generator should **only** be connected to electrical devices, either directly or with an extension cord. NEVER CONNECT TO A BUILDING ELECTRICAL SYSTEM without a qualified electrician and connected to a transfer switch as a separately derived system. Such connections must comply with local electrical laws and codes. Failure to comply can create a back-feed, which may result in serious injury or death to utility workers.

**NOTE:** For power outages, permanently installed, stationary generators are better suited for providing backup power to your home. Even a properly connected portable generator can become overloaded. This may result in overheating or stressing the machine's components, possibly leading to generator failure.



# USING YOUR GENERATOR

## CO SENSOR INFORMATION

The CO Watchdog carbon monoxide monitoring system (Fig. 14 - 1) measures the accumulation of poisonous CO gas while the generator is running. If the level of CO gas gets too high, the CO Watchdog system will automatically shut down the generator. **This system is not a substitute for an indoor CO alarm.**

Whenever the CO Watchdog system shuts down the generator, the LED on the generator control panel (Fig. 14 - 1) will **blink red** for at least 5 minutes after the generator is shut down. **If you notice that the LED is blinking red, vacate the area immediately.** Go to an open, outdoor area. Ventilate the area around the generator thoroughly before returning. Let the generator stay shut down for a few minutes before restarting the engine. This should allow carbon monoxide to dissipate from the area. If you restart the generator and the CO Watchdog detects that CO levels are still too high, it will shut down the generator again. If CO levels are low enough, the generator will run normally.

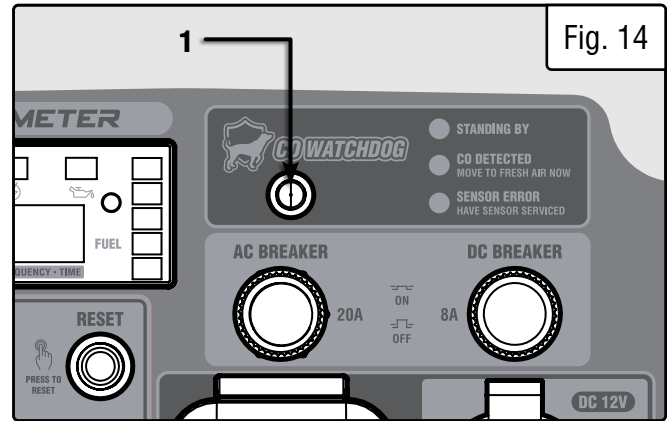

Fig. 14

**NOTE:** if the generator is oriented so that the engine exhaust is blown towards the CO sensor, the generator may shut down.

Ensure that the generator is located in an open outdoor area, with the exhaust pointing away from occupied structures, and pointing away from the prevailing winds, such that those winds do not blow engine exhaust towards the sensor module. If anyone experiences dizziness, headaches, nausea, fatigue, or other symptoms of CO poisoning, get to fresh air immediately and seek the attention of a qualified medical professional. Follow all other directions in this manual regarding the connection and disconnection of electrical devices when starting or shutting down the generator.

When starting the generator, the CO Watchdog LED on the panel may flash. This indicates that the system is running a self-test procedure, and does not indicate a problem.

If the CO Watchdog LED on the panel is **yellow**, a system error has occurred, or the CO sensor has reached the end of its life. Contact WEN customer service (**1-847-429-9263**, M – F 8 – 5 CST, or [techsupport@wenproducts.com](mailto:techsupport@wenproducts.com)) for assistance.

### When operating your generator, please note the following:

- The CO Watchdog does not discriminate in its input; any source of carbon monoxide in the area around the generator could cause it to activate. If the CO Watchdog LED is blinking red, safety measures should be taken immediately.
- Tampering with, disconnecting, or bypassing the CO sensor could cause hazardous conditions, including but not necessarily limited to injury or death, and will void your warranty. The generator will not run with the CO sensor disconnected or bypassed, or if the CO sensor indicates an error.
- The CO sensor has a lifetime of about 7 years, and is capable of monitoring its lifetime. If your generator shows an error light several years after purchase, it may be time to replace the CO sensor. Contact WEN customer service for assistance.

# STOPPING YOUR GENERATOR

## SHUTTING OFF THE GENERATOR

1. Turn off all electrical devices and then unplug the devices from the generator.

**⚠ CAUTION!** Unplugging running devices can cause damage to the generator. Never stop the engine with electrical devices connected and running.

2. Allow generator to run at no load for a few minutes to stabilize internal temperatures.

3. Turn the 4-in-1 switch (Fig. 13 - 1) to the “FUEL OFF” position.

4. If using LPG, turn the LPG tank valve OFF and remove the LPG regulator hose from the tank and inlet on the generator. Push the collar on the LPG quick-connector back to release the end of the LPG regulator hose.

4. The engine will continue to run until the majority of the fuel in the carburetor is consumed, which takes a few minutes. It will then shut off automatically. This feature helps to prevent the carburetor from being clogged by stale fuel, extending your generator’s lifespan.

5. In case you are in a hurry and do not want to wait for the generator to automatically shut down, turn the 4-in-1 switch to the “ENGINE OFF” position and the generator will shut off right away. However, this method will leave stagnant fuel in the carburetor, possibly causing blockages, a shortened lifespan, and other maintenance issues. If this approach is frequently taken, make sure to drain your carburetor before any long storage periods.

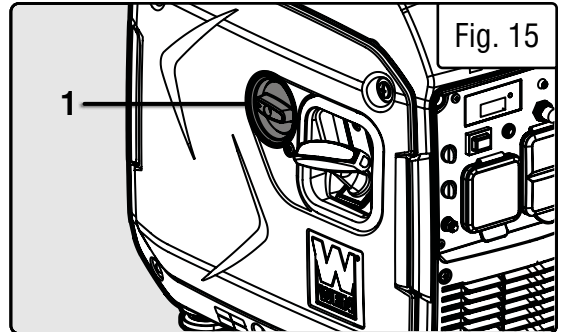

**⚠ WARNING!** Allow the generator to cool for several minutes before touching areas that become hot during use.

**⚠ CAUTION!** Allowing gasoline to sit in the fuel tank for long periods of time can make it difficult to start the generator in the future. Never store the generator for extended periods of time (over 2 months) with fuel in the fuel tank. Refer to “Storing the Generator” on page 28.

# MAINTENANCE

Proper routine maintenance of the generator will help prolong the life of the machine. Please perform maintenance checks and operations according to the schedule in Table 4.

**⚠ CAUTION!** Never perform maintenance operations while the generator is running. Before maintaining or servicing the generator, turn OFF the generator, disconnect all devices and allow the generator to cool down.

If there are any questions about the maintenance procedures listed in this manual, please call **1-847-429-9263** M-F 8-5 CST or email [techsupport@wenproducts.com](mailto:techsupport@wenproducts.com).

Recommended Maintenance Schedule		Every 8 Hours or Daily	Every 25 Hours	Every 3 Months or 50 Hours	Every 6 Months or 100 Hours	Before Storage	As Necessary
<b>Engine Oil</b>	Check Level	x					
	Replace	x**	x**	x*			x
<b>Air Filter</b>	Check			x*			
	Clean			x*			
<b>Spark Plug</b>	Check/Clean/Regap				x		
	Change				x		x
<b>Fuel</b>	Check Level	x					
	Drain					x	x
<b>Carburetor</b>	Drain	x					x
<b>Spark Arrestor</b>	Check/Clean				x		

\* Clean/change more often under dusty conditions or operating under heavy load. Table 4 - Recommended Maintenance Schedule

\*\* Change the oil after the first 8 hours of operation, after the first 25 hours of operation, and every 50 hours after that.

**IMPORTANT GENERATOR MAINTENANCE TIPS:**

- Drain your carburetor after each use and before storage to prevent it from clogging.
- Do not store the generator with fuel inside the tank for more than 2 months - the fuel will go bad.
- Run the generator for at least 20 minutes every month to maximize its lifespan.

## CLEANING THE GENERATOR

Keep the generator clean to prevent improper operation or machine damage from dirt and debris. Inspect all ventilation openings on the generator. These openings must be kept clean and unobstructed. If the generator becomes dirty, use a damp cloth to wipe exterior surfaces. Use a soft bristle brush to loosen dirt and oil and use a vacuum to pick up loose dirt. Use low pressure air (not to exceed 25 PSI) to blow away dirt.

**⚠ CAUTION!** Never clean the generator when it is running! Never clean with a bucket of water or a hose. Water can get inside the working parts of the generator and cause corrosion or a short circuit.

**NOTE:** Failure to properly maintain the generator will void the warranty.

# MAINTENANCE

**⚠ WARNING!** Make sure generator is shut off before performing any inspection or maintenance procedures.

## CHECKING / ADDING OIL

Check the oil level of the generator according to the Recommended Maintenance Schedule in Table 4. The oil level should be checked before each use or every 8 hours of operation. The oil capacity of the generator engine is 16.9 fl. oz. (0.5 L). Add oil when the oil level is low.

For proper type and weight of oil refer to “ADD / CHECK OIL” section. The generator is equipped with an automatic shutoff to protect it from running on low oil. To check the oil level:

1. Make sure the generator is on a level surface. Do not tilt the generator to assist in filling, as oil will flow into engine areas and cause damage. Keep generator level!
2. Open the side panel (to the right of the control panel) by twisting the side panel access knobs (Fig. 16 - 1). Remove and wipe the oil dipstick (Fig. 17) with a clean rag. Insert the dipstick into the oil fill opening without screwing it in.
3. Insert the dipstick into the oil fill opening without screwing in. Remove the dipstick to check the oil mark. Add oil if the oil mark covers less than one half of the dipstick.
4. Using a funnel or appropriate dispenser, slowly add more oil. Repeat step 3 until the oil mark measures between the upper limit mark and half-way mark of the dipstick. Do not over fill the crankcase.
5. Reinstall dipstick and wipe clean any spilled oil with a rag.

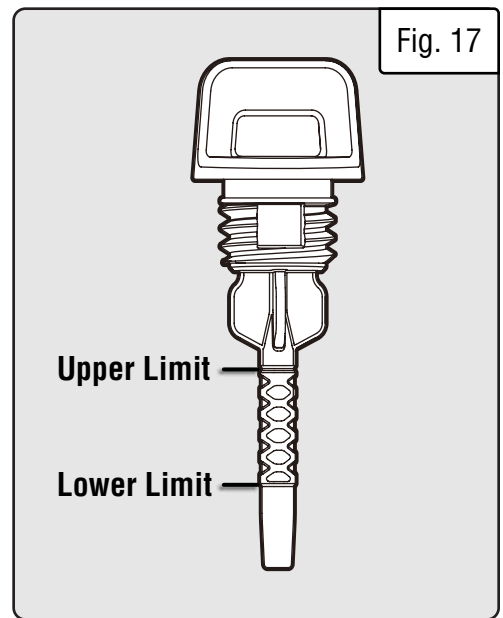
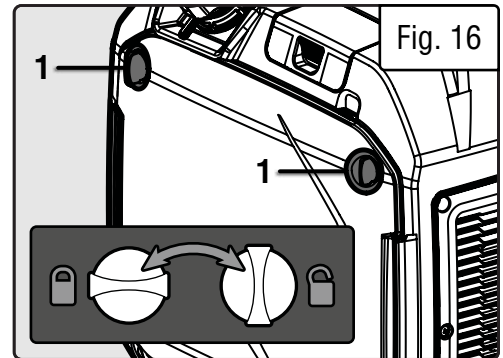

## DRAINING / CHANGING THE OIL

Change the oil according to the Recommended Maintenance Schedule in Table 4. Change the oil more often if operating under heavy load or high ambient temperatures. It is also necessary to drain the oil from the crankcase if it has become contaminated with water or dirt. Changing the oil when the engine is warm allows for complete drainage. Drain the oil from the generator according to the following steps.

1. Place generator on an elevated platform such as table or desk. Prepare a container underneath the oil fill to catch the oil as it drains.
2. Open the side panel. Remove the dipstick and tilt the generator towards you to allow the oil to drain from the engine completely.
3. Reinstall the oil dipstick and tighten it securely. Wipe clean any oil spillage and close the side panel.

**NOTE:** Do not dispose of used motor oil in the trash or down a drain. Please call a local recycling center or auto garage to arrange proper oil disposal.

# MAINTENANCE

## SPARK PLUG MAINTENANCE

The spark plug is important for proper engine operation. A good spark plug should be intact, free of deposits, and properly gapped. Refer to Recommended Maintenance Schedule in Table 4 for instructions on maintaining. To inspect the spark plug:

1. Open the spark plug access cover (Fig. 18 - 1).
2. Pull up to remove the black plastic spark plug boot. Be careful not to tear any insulation or wire.
3. Use a spark plug wrench to unscrew and remove the spark plug from the engine.
4. Visually inspect the spark plug for cracks or excessive electrode wear. If the electrodes are worn or burned, or porcelain is cracked, replace with a Torch E6RTC (NGK BPR6HS) spark plug (**Part No. 56360iX-002**), available at [wenproducts.com](http://wenproducts.com).
5. If re-using the spark plug, use a wire brush to clean any dirt from around the spark plug base then re-gap the spark plug.
6. Measure the plug gap with a wire gauge (Fig. 19). The gap should be 0.023 - 0.031 in. (0.6 - 0.8 mm). Carefully adjust the gap if necessary.
7. Screw the spark plug back into the spark plug hole by hand. After the spark plug is properly seated, use the spark plug wrench to tighten it.
8. Reinstall the spark plug boot over the spark plug.
9. Reinstall the spark plug access cover.

**NOTE:** The recommended tightening of the spark plug is 1/2 to 3/4 of a turn after the spark plug gasket contacts the spark plug hole, or 11.1-14.7 ft-lbs (15 - 20 Nm). Do not over-tighten the spark plug.

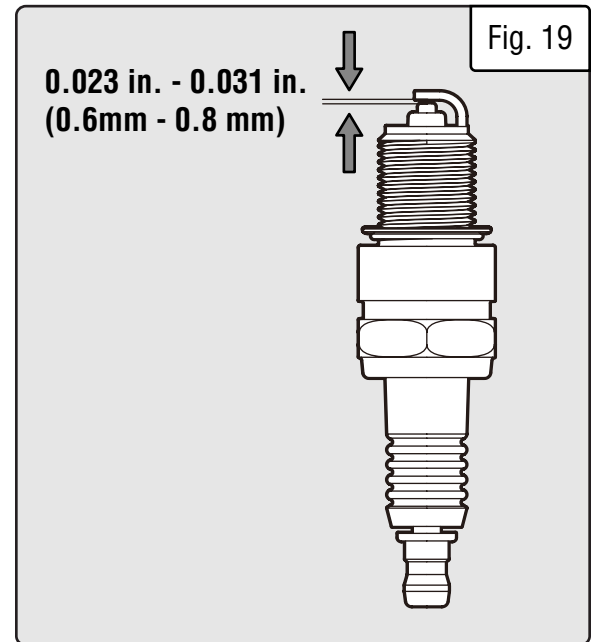
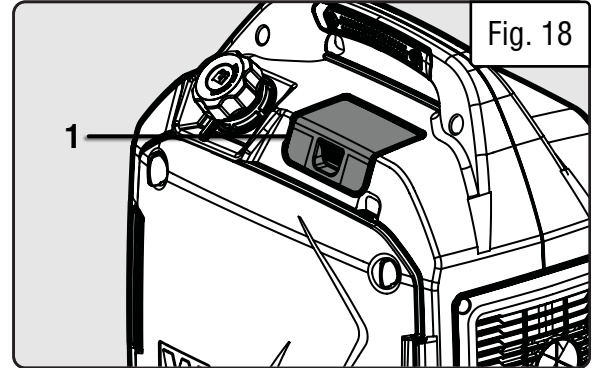

## AIR FILTER MAINTENANCE

Routine maintenance of the air filter helps maintain proper airflow to the carburetor. Occasionally check that the air filter is free of excessive dirt. The air filter should be checked every 50 hours of use. Refer to Recommended Maintenance Schedule in Table 4.

1. Open the side panel (to the right of the control panel) by twisting the side panel access knobs (Fig. 20 - 1).
2. Open the air filter cover (Fig. 21 - 1), and remove the foam air filter element from the casing.
3. Check and clean the foam air filter element. Wash the filter element in warm soapy water. Squeeze it thoroughly dry in a clean cloth. Saturate the element in clean engine oil and squeeze off excess oil in a clean absorbent cloth. A small amount of oil in the element is normal and necessary for the engine to work properly. If the element is damaged, replace it with a new one (**part. no. 56360iX-063, available at wenproducts.com**).
4. Reinstall the air filter element and close the air filter cover. Close the air filter cover. Replace the side cover and secure it with the screws. Reinstall the oil access panel.

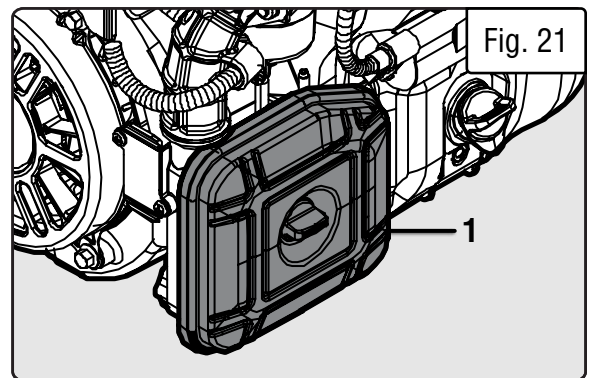
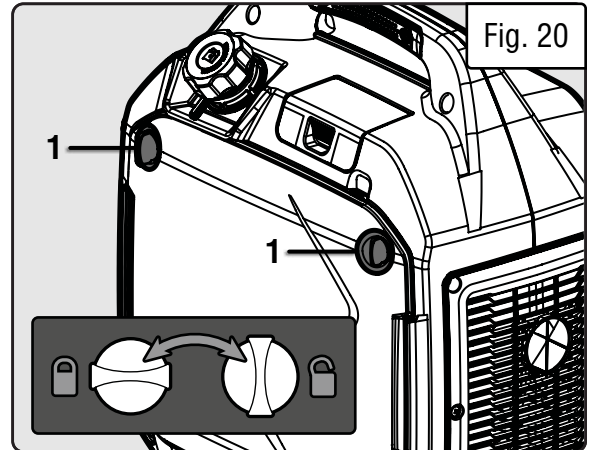

**⚠ CAUTION!** Running the engine with a dirty, damaged, or missing air filter element will result in possible danger and cause the engine to wear out prematurely.

## DRAINING THE CARBURETOR

**Drain the carburetor after every use and before storing the generator** (refer to Table 4). Draining the carburetor can help prevent build-up and blockages caused by stagnant fuel inside of the carburetor.

1. Prepare an approved gasoline storage container.
2. Open the side panel (to the right of the control panel) by twisting the side panel access knobs (Fig. 20 - 1).
3. Open up the carburetor drain screw (Fig. 22 - 1) with a Phillips screwdriver and drain out any gasoline that has built up inside the carburetor.
4. Once the fuel has drained, tighten the drain screw with the screwdriver.

**NOTE:** Make sure to drain your carburetor before storing the generator for long periods of time.

5. Close the side panel.

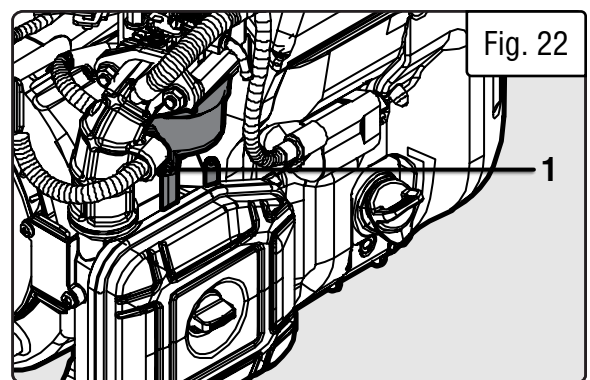

## MAINTENANCE

### SPARK ARRESTOR MAINTENANCE

It is recommended to inspect and clean the spark arrestor (Fig. 23 - 1) every 100 hours of operation.

1. The spark arrestor is located outside the muffler, which gets very hot during operation. Allow the engine to cool completely before servicing the spark arrestor.
2. Unscrew the six Phillips head screws and remove the muffler cover (Fig. 23 - 2).
3. Remove the screw that holds spark arrestor to muffler.
4. Remove the spark arrestor screen.
5. Carefully clean and remove the carbon deposits from the spark arrestor screen with a wire brush. Replace the spark arrestor if it is damaged (**part no. 56202i-039, available for purchase at wenproducts.com**).
6. Reinstall the spark arrestor in the muffler and secure it in place with the screw.
7. Replace the muffler cover and secure it with the six screws.

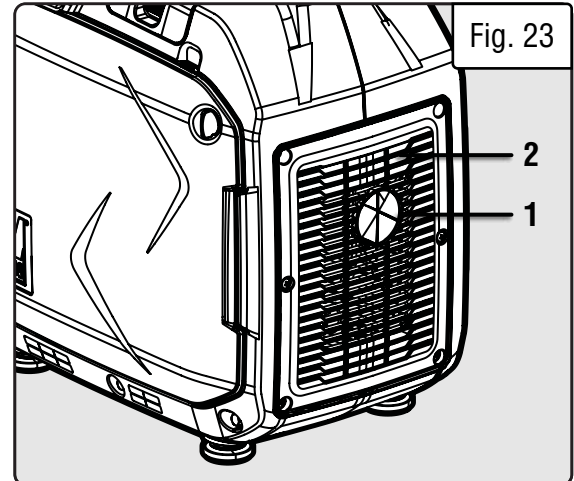

### DRAINING THE FUEL TANK

1. Prepare an approved gasoline-storage container. Make sure the engine switch is turned to OFF.
2. Open the right side panel to access the carburetor, as instructed on the previous page.
3. Open the carburetor drain screw and turn the 4-in-1 switch to "RUN". This will allow gasoline to drain from the gas tank through the carburetor.

**NOTE:** It may take a few hours for your tank to drain completely, depending on the amount of gasoline in the tank.

4. Once the gasoline has drained fully, close the carburetor drain screw, turn the engine switch to OFF, and close the side panel.

**⚠ CAUTION!** Running the engine with a dirty, damaged, or missing air filter will result in possible danger and cause the engine to wear out prematurely.

## TRANSPORTATION & STORAGE

### TRANSPORTING THE GENERATOR

To prevent fuel spillage when transporting, be sure to perform the following:

1. Tighten the fuel cap.
2. Flip the 4-in-1 switch to the “ENGINE OFF” position.
3. Drain the fuel tank if possible. Refer to page 28, “Draining the Fuel Tank.”
4. Keep the generator upright. Never place the generator on its side or upside down - doing so could damage the internal components of the generator and make it difficult to start.

 **WARNING!** Avoid direct sunlight inside a vehicle. If the generator is left in an enclosed vehicle for many hours, the high temperature could cause the fuel to vaporize and result in a possible explosion.

### STORING THE GENERATOR

Shut off the generator and allow the unit to cool to room temperature before storing it. NEVER place any type of storage cover on the generator while it is still hot. Do not obstruct any ventilation openings.

Follow the procedures below for properly storing your generator. We highly recommend running your generator once a month for 20 to 30 minutes. Plug in a small load in to ensure there is proper power output.

#### For Short Periods (30 to 60 Days):

- Drain the carburetor. Refer to page 30, “DRAINING THE CARBURETOR.”
- **Add fuel stabilizer:** Follow the suggested portions and instructions of your preferred stabilizer. Run the engine for 15 to 20 minutes, allowing the fuel stabilizer to mix with the gasoline and circulate through the carburetor, and then top off with fuel. Filling the fuel tank full reduces the amount of air in the tank and helps fight deterioration of fuel.

#### For Extended Periods (Over 60 Days):

- Drain the fuel tank and carburetor (see “DRAINING THE FUEL TANK”). Never store generator with fuel in the tank for more than two months.
- Change the engine oil (see “CHANGING OIL”).

 **WARNING!** Store the generator upright in a cool and dry location, away from sources of heat, open flames, sparks or pilot lights.

### PRODUCT DISPOSAL

Do not dispose of a used generator or parts with your household waste. This product contains electrical or electronic components that should be recycled. Please take this product to your local recycling facility for responsible disposal to minimize its environmental impact.

Do not dispose of used oil or fuel in the trash or down a drain. Please contact your local recycling center or auto garage to arrange proper oil/fuel disposal.



**Please recycle the packaging and electronic components where facilities exist. Please contact your local auto garage or recycling facility to properly dispose of oil/fuel.**



## TROUBLESHOOTING GUIDE

**⚠ WARNING!** Stop using the generator immediately if any of the following problems occur or risk serious personal injury. If you have any questions, please contact customer service at **1-847-429-9263** (M-F 8-5 CST), or email **techsupport@wenproducts.com**.

PROBLEM	POSSIBLE CAUSE	SOLUTION
<b>Engine will not start.</b>	Engine switch is set to OFF.	Set engine switch to ON.
	Choke is open.	Close the choke.
	Engine is out of fuel.	Add fuel.
	Engine is filled with contaminated or old fuel.	Drain the fuel in the tank. Fill with fresh fuel.
	Spark plug is dirty.	Clean the spark plug.
	Spark plug is broken.	Replace spark plug.
	Oil level is low.	Add or replace oil. This generator is equipped with a low oil sensor. The engine will not start unless the oil level is sufficient.
	Carburetor is air locked.	Remove the nut from the bottom of the carburetor. Take off the carburetor to allow it to reset. Place the carburetor back and re-install the nut.
<b>Engine runs but there is no electrical output.</b>	LPG cylinder is out of fuel, and LPG regulator hose is connected.	Disconnect LPG regulator hose from generator. Make sure there is enough gasoline in the tank.
	Circuit breaker has been tripped due to overload.	Disconnect all the loads. Wait for two minutes and push the circuit breaker to the ON position to reset it.
	Bad connecting cords/wires.	Check the power cords and extension cords. Do not use if any cord is damaged. Replace damaged cords immediately.
<b>Generator runs but does not support all electrical devices connected.</b>	Bad electrical device connected to the generator.	Try connecting a different device.
	Generator is overloaded.	Perform these steps: 1. Turn off all electrical devices. 2. Unplug all electrical devices. 3. Turn off generator. 4. Wait several minutes. 5. Restart generator. 6. Try connecting few electrical loads to the generator.
	Short circuit in one of the devices.	Try disconnecting any faulty or short-circuited electrical loads.
<b>Engine is "Hunting" during Operation (Engine RPM is fluctuating).</b>	The air filter is dirty.	Clean or replace the air filter element (see page 20).
	1. The fuel isn't running through the fuel valve. 2. The air filter is clogged. 3. The muffler or spark arrestor is blocked 4. There is gunk in the carburetor preventing a consistent fuel/air mixture.	Turn off the generator and wait for it to cool down. Perform the following steps: 1. Check if the fuel is properly and consistently going through the fuel valve 2. Check for any blockage in the air filter. Check and clean the air filter as necessary. 3. Check if the spark arrestor is blocked. Clean with metal brush as necessary. 4. Use "Gunk remover" spray on the carburetor jets.

# WIRING DIAGRAM

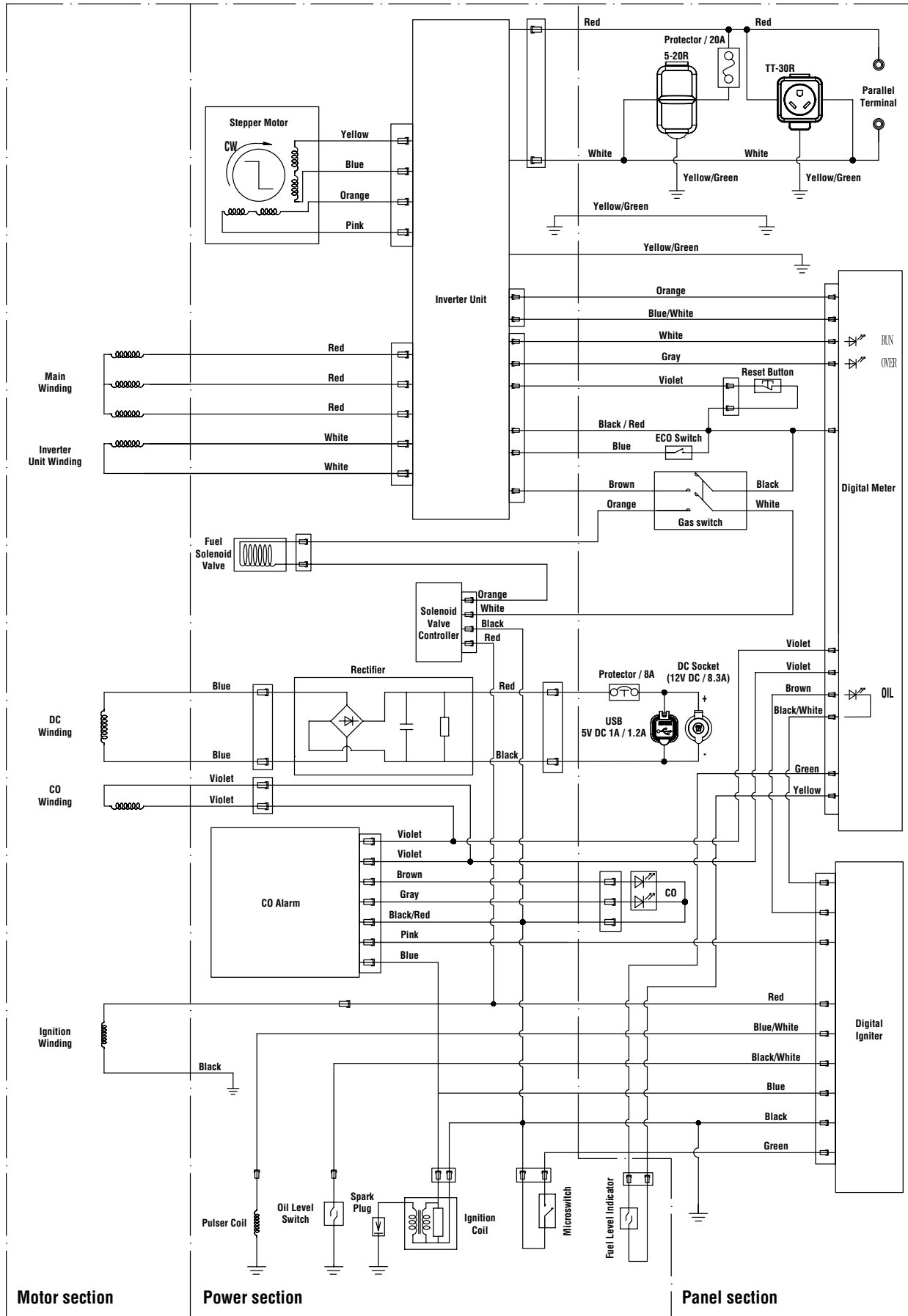

# EXPLODED VIEW & PARTS LIST

## GENERATOR

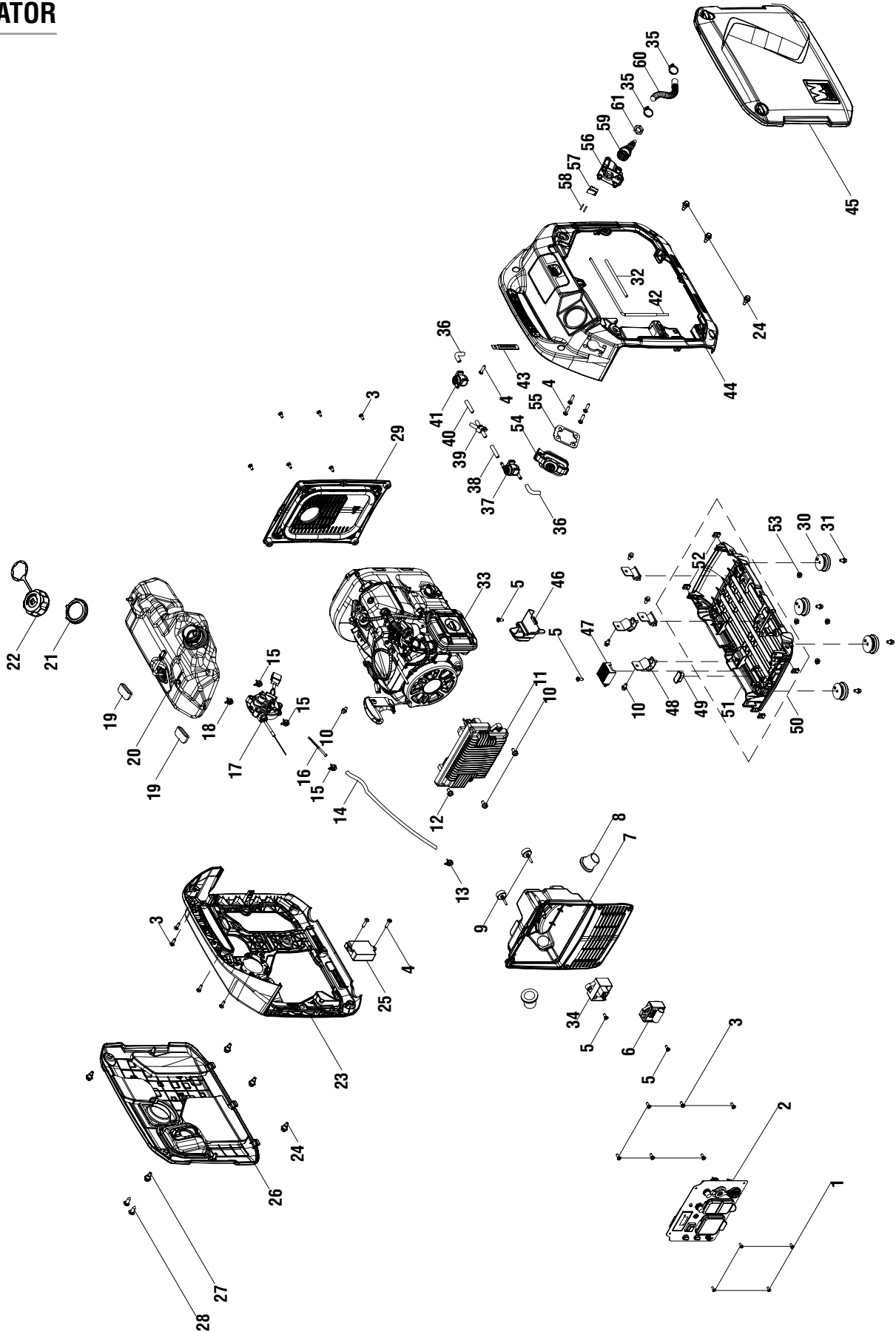

## EXPLODED VIEW & PARTS LIST

### GENERATOR

NO.	PART NO.	DESCRIPTION	QTY.
1	56202i-001	Screw, M4x10	4
2	DF360iX-002	Control Panel Assembly	1
3	56202i-025	Screw, M5x16	19
4	56360iX-104	Self-tapping Screw, ST4.2x19	7
5	56360iX-105	Screw, M4x16	4
6	56360iX-106	Ignition Module	1
7	56360iX-107	Front Panel	1
8	56360iX-108	Wire Jacket	2
9	56360iX-109	Bumper Pad	2
10	56202i-013	Bolt, M6x12	7
11	56360iX-111	Inverter	1
12	56360iX-112	Bolt, M5x8	1
13	56360iX-113	Clamp	1
14	56360iX-114	Fuel Hose	1
15	56360iX-115	Clamp	3
16	56360iX-116	Fuel Filter	1
17	56360iX-117	Switch Assembly	1
18	56360iX-118	Clamp	1
19	56202i-030	Damping Pad	2
20	56360iX-120	Fuel Tank	1
21	56202i-033	Fuel Tank Cap Nut	1
22	56360iX-122	Fuel Cap	1
23	56360iX-123	Left Hull Assembly	1
24	56202i-022	Alignment Bolt	6
25	56360iX-125	CO Alarm	1
26	DF360iX-026	Left Cover Panel	1
27	56360iX-127	Phillips Bolt	2
28	56360iX-128	Screw,ST4.2x13	2
29	56360iX-129	Service Window Assembly	1
30	56360iX-154	Rubber Cap	4
31	56202i-051	Bolt, M6x12	4
32	DF360iX-032	Fuel Hose Jacket	1

NO.	PART NO.	DESCRIPTION	QTY.
33	DF360iX-033	Engine Assembly	1
34	DF360iX-034	Solenoid Valve Controller	1
35	DF360iX-035	Fuel Hose Clamp	2
36	56360iX-136	Fuel Hose	2
37	56360iX-137	Roll Over Valve	1
38	56360iX-138	Fuel Hose	1
39	56360iX-139	Fuel Tee Pipe	1
40	56360iX-140	Fuel Hose	1
41	56360iX-141	Roll Over Valve	1
42	DF360iX-042	Fuel Hose	1
43	DF360iX-043	Clip	1
44	DF360iX-044	Right Hull Assembly	1
45	DF360iX-045	Right Cover Panel	1
46	56360iX-146	Shroud Cover	1
47	56360iX-147	Rectifier	1
48	56202i-053	Damping Pad	4
49	56202i-054	Damping Pad	1
50	56360iX-150	Switch Box Base	1
51	56360iX-151	Switch Box Base Body	1
52	56202i-020	Fuel Tank Mount Thread Tab	4
53	56202i-056	Nut, M6	4
54	DF360iX-054	Connector Guard Assembly	1
55	DF360iX-055	Gasket	1
56	DF360iX-056	Connector Seat	1
57	DF360iX-057	Wire Harness	1
58	DF360iX-058	Pin, 2.3 x 17.5mm	2
59	DF360iX-059	LPG Quick-Connector	1
60	DF360iX-060	LPG Hose	1
61	DF360iX-061	Nut	
N.P.	DF360iX-062	LPG Regulator Hose Assembly	1

**NOTE:** Not all parts may be available for purchase. Parts and accessories that wear down over the course of normal use are not covered under the warranty.

# EXPLODED VIEW & PARTS LIST

## ENGINE

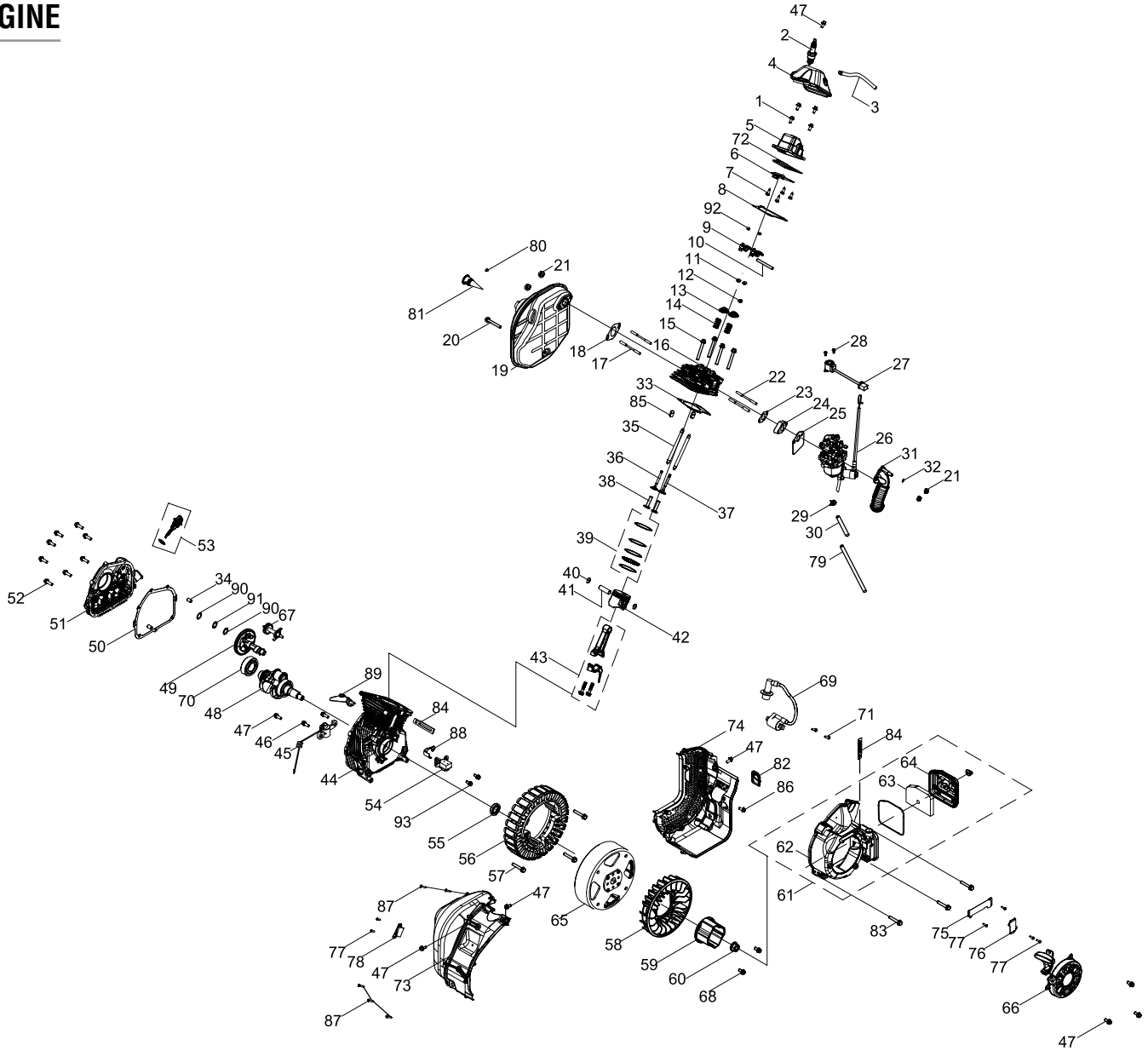

NO.	PART NO.	DESCRIPTION	QTY.	NO.	PART NO.	DESCRIPTION	QTY.
1	56202i-152	Bolt, M6x20	4	12	56360iX-012	Intake Valve Seal	1
2	56360iX-002	Spark Plug, Torch E6RTC (NGK BPR6HS)	1	13	56202i-113	Valve Spring Seat	2
3	56202i-103	Breather Hose	1	14	56360iX-014	Valve Spring	2
4	56360iX-004	Valve Cover	1	15	56360iX-015	Bolt, M8x60	4
5	56360iX-005	Valve Cover Assembly	1	16	DF360iX-116	Cylinder Head	1
6	56360iX-006	Inner Cover, Valve Cover	1	17	56360iX-017	Stud, M6x82	2
7	56202i-107	Screw, M3x6	4	18	56360iX-018	Gasket, Muffler	1
8	56360iX-008	Gasket, Valve Cover	1	19	56360iX-019	Muffler	1
9	56360iX-009	Rocker Arm Assembly	2	20	56360iX-020	Bolt, M6x75	1
10	56360iX-010	Rocker Arm Coreshaft	1	21	56202i-121	Nut, M6	4
11	56202i-111	Valve Locker	2	22	56202i-122	Stud, M6x87	2

## EXPLODED VIEW & PARTS LIST

### ENGINE

NO.	PART NO.	DESCRIPTION	QTY.	NO.	PART NO.	DESCRIPTION	QTY.
23	56360iX-023	Gasket, Carburetor Insulator	1	60	56360iX-060	Nut, M14x1.5	1
24	56360iX-024	Insulator	1	61	56360iX-061	Recoil Starter	1
25	56360iX-025	Gasket, Carburetor	1	62	56360iX-062	Blower Housing	1
26	DF360iX-127	Carburetor	1	63	56360iX-063	Air Filter Element	1
27	56202i-127	Stepper Motor	1	64	56360iX-064	Air Filter Cover	1
28	56202i-128	Screw, M4x6	2	65	56360iX-065	Rotor	1
29	56360iX-029	Clamp	1	66	56360iX-066	Recoil Starter	1
30	56360iX-030	Fuel Hose	1	67	56360iX-067	Oil Thrower Gear	1
31	56360iX-031	Intake Manifold	1	68	56202i-167	Bolt, M6x14	2
32	56202i-132	Clamp	1	69	56360iX-069	Ignition Coil	1
33	56360iX-033	Gasket, Cylinder Head	1	70	56360iX-070	Bearing, 6205E	1
34	56202i-134	Pin, $\phi$ 8x12	2	71	56360iX-071	Self-tapping Screw, ST4.8x20	2
35	56360iX-035	Push Rod	2	72	56360iX-072	Gasket, Cylinder Cover	1
36	56360iX-036	Exhaust Valve	1	73	56360iX-073	Cylinder Head Baffle	1
37	56360iX-037	Intake Valve	1	74	56360iX-074	Cylinder Head Baffle	1
38	56360iX-038	Tappet	2	75	56360iX-075	Clip Base	1
39	56360iX-039	Piston Ring Set	1	76	56360iX-076	Clip Base	1
40	56360iX-040	Circlip	2	77	56360iX-077	Self-tapping Screw, ST4.2x16	6
41	56360iX-041	Piston Pin	1	78	56360iX-078	Idle Spring	1
42	56360iX-042	Piston	1	79	56360iX-079	Fuel Hose Jacket	1
43	56360iX-043	Connecting Rod Assembly	1	80	56202i-038	Self-tapping Screw, ST4.2x9.5	1
44	56360iX-044	Crankcase	1	81	56202i-039	Spark Arrestor	1
45	56360iX-045	Oil Sensor	1	82	DF360iX-082	O-ring, Dipstick	1
46	56202i-146	Bolt, M6x16	2	83	56360iX-083	Bolt, M6x45	3
47	56202i-147	Bolt, M6x12	9	84	56360iX-084	Clip	2
48	56360iX-048	Crankshaft	1	85	56360iX-085	Pin, $\phi$ 10x16	2
49	56360iX-049	Camshaft	1	86	56360iX-086	Bolt, M6x45	1
50	56360iX-050	Gasket, Cylinder Cover	1	87	56360iX-087	Self-tapping Screw, ST4.2x25	5
51	56360iX-051	Crankcase Cover	1	88	56360iX-088	Wind Board	1
52	56360iX-052	Bolt, M6x25	8	89	56360iX-089	Wind Board	1
53	56202i-153	Dipstick	1	90	56360iX-090	Washer, $\phi$ 14.2x0.5x $\phi$ 21	2
54	56360iX-054	Trigger	1	91	56360iX-091	Corrugated Gasket	1
55	56360iX-055	Oil Seal, $\phi$ 25x $\phi$ 41.25x6	1	92	56360iX-092	Valve Adjust Cap, Exhaust	2
56	56360iX-056	Stator Assembly	1	93	56360iX-093	Bolt, M6x12	2
57	56360iX-057	Bolt, M6x38	3	N.P.	DF360iX-HA39	High-Altitude Kit, 3000 - 9000 ft	1
58	56360iX-058	Cooling Fan	1				
59	56360iX-059	Starter Cup	1				

## EXPLODED VIEW & PARTS LIST

### CONTROL PANEL

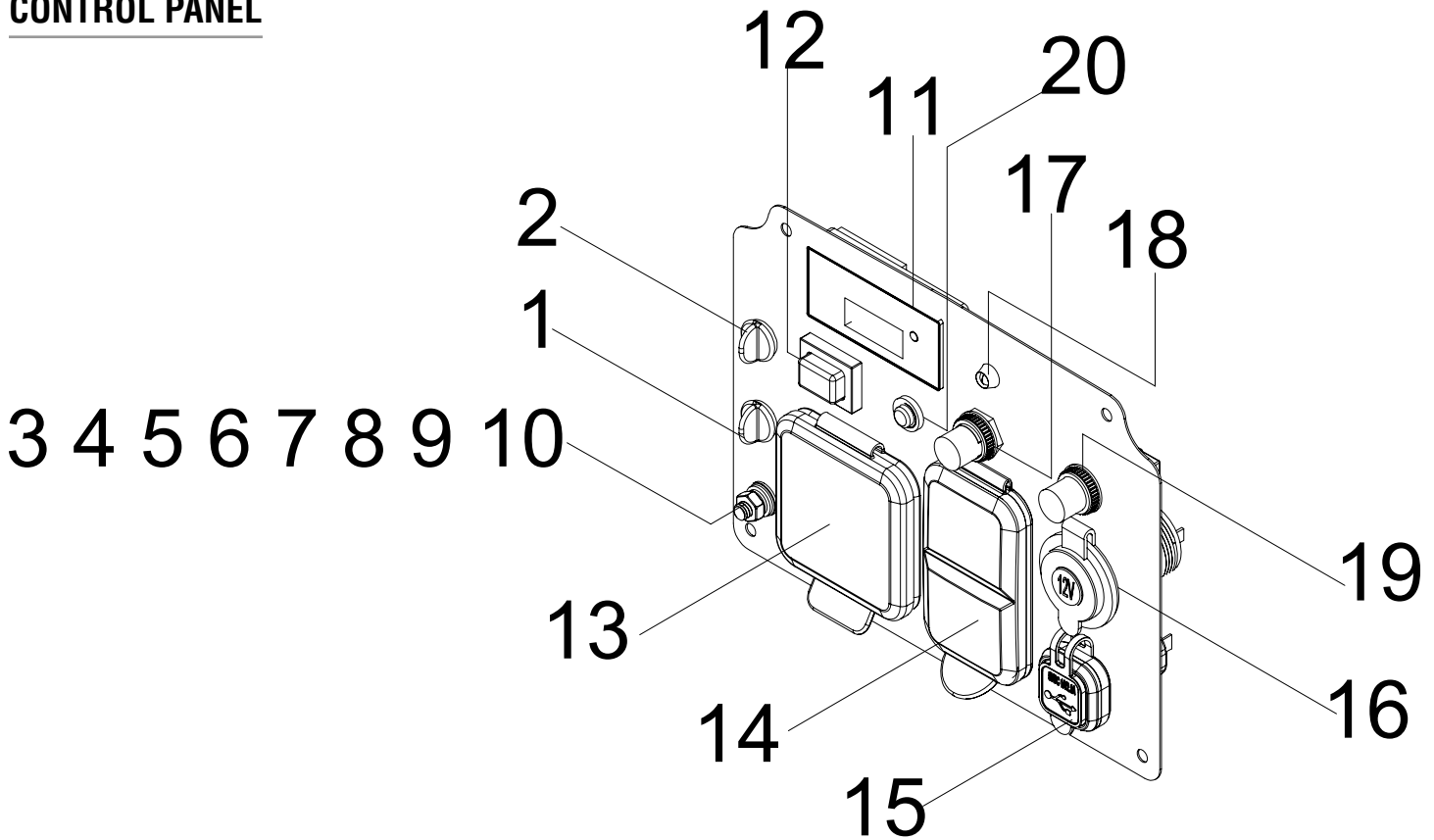

NO.	PART NO.	DESCRIPTION	QTY.
1	56203i-005.14B	Parallel Outlet (Black)	1
2	56203i-005.14R	Parallel Outlet (Red)	1
3	56360iX-159	Nut, M6	1
4	56203i-005.11	Washer, 6mm	1
5	56203i-005.12	Washer, 6mm	1
6	56360iX-162	Earth Stud	1
7	DF360iX-207	Washer, 6mm	1
8	56360iX-164	Washer, 5mm	1
9	56360iX-165	Washer, 5mm	1
10	56360iX-166	Nut, M5	1
11	DF360iX-211	Multi-meter	1

NO.	PART NO.	DESCRIPTION	QTY.
12	56203i-005.4	Eco-mode Switch	1
13	DG4500iX-207	NEMA TT-30R 120V 30A AC Outlet	1
14	DG4500iX-208	NEMA 5-20R 120V 20A AC Duplex Outlet	1
15	56360iX-171	USB	1
16	56203i-005.2	DC 12V Outlet	1
17	56500-208	Breaker, AC 20A	1
18	56360iX-175	LED	1
19	56203i-005.5	Breaker, AC 8A	1
20	DF360iX-020	Reset Button	1

**NOTE:** Not all parts may be available for purchase. Parts and accessories that wear down over the course of normal use are not covered under the warranty.

# **WARRANTY STATEMENT**

WEN Products is committed to building tools that are dependable for years. Our warranties are consistent with this commitment and our dedication to quality.

## **LIMITED WARRANTY OF WEN PRODUCTS FOR HOME USE**

GREAT LAKES TECHNOLOGIES, LLC (“Seller”) warrants to the original purchaser only, that this WEN consumer product will be free from defects in material or workmanship during personal use for a period of three (3) years from date of purchase or 500 hours of use; whichever comes first. Ninety days for all WEN products if the tool is used for professional or commercial use. Purchaser has 30 days from the date of purchase to report missing or damaged parts. Parts and labor are covered for one (1) year under this limited warranty; parts only are covered for three (3) years under this limited warranty.

**SELLER’S SOLE OBLIGATION AND YOUR EXCLUSIVE REMEDY** under this Limited Warranty and, to the extent permitted by law, any warranty or condition implied by law, shall be the replacement of parts, without charge, which are defective in material or workmanship and which have not been subjected to misuse, alteration, careless handling, mis-repair, abuse, neglect, normal wear and tear, improper maintenance, improper storage, incorrect lubricants / fuels, or other conditions adversely affecting the Product or the component of the Product, whether by accident or intentionally, by persons other than Seller. To make a claim under this Limited Warranty, you must make sure to keep a copy of your proof of purchase that clearly defines the Date of Purchase (month and year) and the Place of Purchase. Place of Purchase must be a direct vendor of Great Lakes Technologies, LLC. Purchasing through third party vendors, including but not limited to garage sales, pawn shops, resale shops, or any other secondhand merchant, voids the warranty included with this product. Contact [techsupport@wenproducts.com](mailto:techsupport@wenproducts.com) or 1-847-429-9263 with the following information to make arrangements: your shipping address, phone number, serial number, required part numbers, and proof of purchase. Damaged or defective parts and products may need to be sent to WEN before the replacements can be shipped out.

Upon the confirmation of a WEN representative, your product may qualify for repairs and service work. When returning a product for warranty service, the shipping charges must be prepaid by the purchaser. The product must be shipped in its original container (or an equivalent), properly packed to withstand the hazards of shipment. The product must be fully insured with a copy of the proof of purchase enclosed. There must also be a description of the problem in order to help our repairs department diagnose and fix the issue. Repairs will be made and the product will be returned and shipped back to the purchaser at no charge for addresses within the contiguous United States.

THIS LIMITED WARRANTY DOES NOT APPLY TO ITEMS THAT WEAR OUT FROM REGULAR USAGE OVER TIME, INCLUDING FILTERS, SPARK PLUGS, VOLTAGE REGULATORS, BRUSHES, GASKETS, O-RINGS, WHEEL KITS, BATTERIES, RECOIL STARTERS, HIGH PRESSURE HOSES, SPRAY GUNS, ETC. ANY IMPLIED WARRANTIES SHALL BE LIMITED IN DURATION TO THREE (3) YEARS FROM DATE OF PURCHASE. SOME STATES IN THE U.S. AND SOME CANADIAN PROVINCES DO NOT ALLOW LIMITATIONS ON HOW LONG AN IMPLIED WARRANTY LASTS, SO THE ABOVE LIMITATION MAY NOT APPLY TO YOU.

IN NO EVENT SHALL SELLER BE LIABLE FOR ANY INCIDENTAL OR CONSEQUENTIAL DAMAGES (INCLUDING BUT NOT LIMITED TO LIABILITY FOR LOSS OF PROFITS) ARISING FROM THE SALE OR USE OF THIS PRODUCT. SOME STATES IN THE U.S. AND SOME CANADIAN PROVINCES DO NOT ALLOW THE EXCLUSION OR LIMITATION OF INCIDENTAL OR CONSEQUENTIAL DAMAGES, SO THE ABOVE LIMITATION OR EXCLUSION MAY NOT APPLY TO YOU.

THIS LIMITED WARRANTY GIVES YOU SPECIFIC LEGAL RIGHTS, AND YOU MAY ALSO HAVE OTHER RIGHTS WHICH VARY FROM STATE TO STATE IN THE U.S., PROVINCE TO PROVINCE IN CANADA AND FROM COUNTRY TO COUNTRY.

THIS LIMITED WARRANTY APPLIES ONLY TO ITEMS SOLD WITHIN THE UNITED STATES OF AMERICA, CANADA AND THE COMMONWEALTH OF PUERTO RICO. FOR WARRANTY COVERAGE WITHIN OTHER COUNTRIES, CONTACT THE WEN CUSTOMER SUPPORT LINE. FOR WARRANTY PARTS OR PRODUCTS REPAIRED UNDER WARRANTY SHIPPING TO ADDRESSES OUTSIDE OF THE CONTIGUOUS UNITED STATES, ADDITIONAL SHIPPING CHARGES MAY APPLY.