

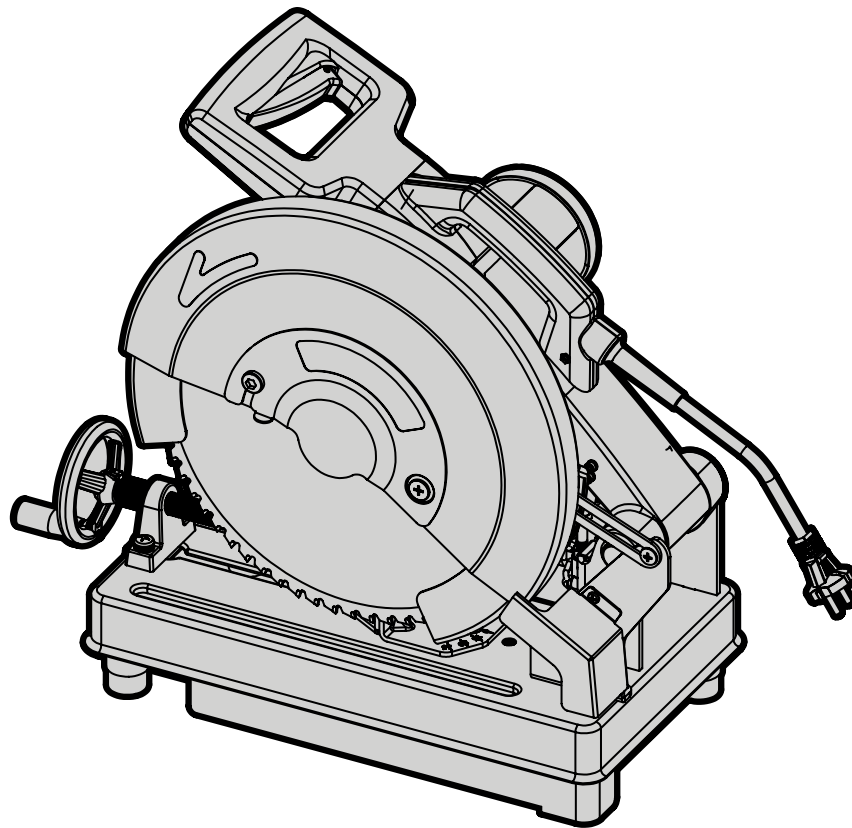

MODEL CM1446

14-INCH CHOP SAW

Instruction Manual



NEED HELP? CONTACT US!

Have product questions? Need technical support? Please feel free to contact us:



1-800-232-1195 (M-F 8AM-5PM CST)



TECHSUPPORT@WENPRODUCTS.COM

IMPORTANT: Your new tool has been engineered and manufactured to WEN's highest standards for dependability, ease of operation, and operator safety. When properly cared for, this product will supply you years of rugged, trouble-free performance. Pay close attention to the rules for safe operation, warnings, and cautions. If you use your tool properly and for its intended purpose, you will enjoy years of safe, reliable service.

For replacement parts and the most up-to-date instruction manuals, visit ***WENPRODUCTS.COM***

CONTENTS

WELCOME	3
Introduction	3
Specifications.....	3
SAFETY	4
General Safety Rules	4
Chop Saw Safety Warnings.....	6
Electrical Information.....	8
BEFORE OPERATING	9
Unpacking & Packing List	9
Know Your Chop Saw	10
Assembly & Adjustments.....	11
OPERATION & MAINTENANCE	14
Operation	14
Maintenance.....	16
Troubleshooting Guide.....	17
Exploded View & Parts List.....	19
Warranty Statement	22

To purchase accessories for your tool, visit ***WENPRODUCTS.COM***

Professional Metal Saw Blade (Model BL1466)
Replacement Carbon Brush (Part CM1452-035)

INTRODUCTION

Thanks for purchasing the WEN Chop Saw. We know you are excited to put your tool to work, but first, please take a moment to read through the manual. Safe operation of this tool requires that you read and understand this operator's manual and all the labels affixed to the tool. This manual provides information regarding potential safety concerns, as well as helpful assembly and operating instructions for your tool.

 Indicates danger, warning, or caution. The safety symbols and the explanations with them deserve your careful attention and understanding. Always follow the safety precautions to reduce the risk of fire, electric shock or personal injury. However, please note that these instructions and warnings are not substitutes for proper accident prevention measures.

NOTE: The following safety information is not meant to cover all possible conditions and situations that may occur. WEN reserves the right to change this product and specifications at any time without prior notice.

At WEN, we are continuously improving our products. If you find that your tool does not exactly match this manual, please visit wenproducts.com for the most up-to-date manual or contact our customer service at **1-800-232-1195**.

Keep this manual available to all users during the entire life of the tool and review it frequently to maximize safety for both yourself and others.

SPECIFICATIONS

Model Number	CM1446
Motor	120V, 60 Hz, 15A
No-Load Speed	1450 RPM
Blade Part Number	BL1466
Blade Size	14 Inches (355 mm) TCT
Arbor Size	1 Inch (25.4 mm)
Kerf	2.4 mm
Teeth	66T
Miter Table Angles	0° - 45°
Cutting Capacity	Full cutting capacity specs can be found on page 15
Weight	49 lbs
Product Dimensions	20.5 in. x 13 in. x 16.75 in.

GENERAL SAFETY RULES

 **WARNING!** Read all safety warnings and all instructions. Failure to follow the warnings and instructions may result in electric shock, fire and/or serious injury.

Safety is a combination of common sense, staying alert and knowing how your item works. The term “power tool” in the warnings refers to your mains-operated (corded) power tool or battery-operated (cordless) power tool.

SAVE THESE SAFETY INSTRUCTIONS.

WORK AREA SAFETY

- 1. Keep work area clean and well lit.** Cluttered or dark areas invite accidents.
- 2. Do not operate power tools in explosive atmospheres, such as in the presence of flammable liquids, gases or dust.** Power tools create sparks which may ignite the dust or fumes.
- 3. Keep children and bystanders away while operating a power tool.** Distractions can cause you to lose control.

ELECTRICAL SAFETY

- 1. Power tool plugs must match the outlet. Never modify the plug in any way. Do not use any adapter plugs with earthed (grounded) power tools.** Unmodified plugs and matching outlets will reduce risk of electric shock.
- 2. Avoid body contact with earthed or grounded surfaces such as pipes, radiators, ranges and refrigerators.** There is an increased risk of electric shock if your body is earthed or grounded.
- 3. Do not expose power tools to rain or wet conditions.** Water entering a power tool will increase the risk of electric shock.
- 4. Do not abuse the cord. Never use the cord for carrying, pulling or unplugging the power tool. Keep cord away from heat, oil, sharp edges or moving parts.** Damaged or entangled cords increase the risk of electric shock.
- 5. When operating a power tool outdoors, use an extension cord suitable for outdoor use.** Use of a cord suitable for outdoor use reduces the risk of electric shock.

- 6. If operating a power tool in a damp location is unavoidable, use a ground fault circuit interrupter (GFCI) protected supply.** Use of a GFCI reduces the risk of electric shock.

PERSONAL SAFETY

- 1. Stay alert, watch what you are doing and use common sense when operating a power tool. Do not use a power tool while you are tired or under the influence of drugs, alcohol or medication.** A moment of inattention while operating power tools may result in serious personal injury.
- 2. Use personal protective equipment. Always wear eye protection.** Protective equipment such as a respiratory mask, non-skid safety shoes and hearing protection used for appropriate conditions will reduce the risk of personal injury.
- 3. Prevent unintentional starting. Ensure the switch is in the off-position before connecting to power source and/or battery pack, picking up or carrying the tool.** Carrying power tools with your finger on the switch or energizing power tools that have the switch on invites accidents.
- 4. Remove any adjusting key or wrench before turning the power tool on.** A wrench or a key left attached to a rotating part of the power tool may result in personal injury.
- 5. Do not overreach. Keep proper footing and balance at all times.** This enables better control of the power tool in unexpected situations.
- 6. Dress properly. Do not wear loose clothing or jewelry. Keep your hair and clothing away from moving parts.** Loose clothes, jewelry or long hair can be caught in moving parts.

GENERAL SAFETY RULES

⚠ WARNING! Read all safety warnings and all instructions. Failure to follow the warnings and instructions may result in electric shock, fire and/or serious injury.

Safety is a combination of common sense, staying alert and knowing how your item works. The term “power tool” in the warnings refers to your mains-operated (corded) power tool or battery-operated (cordless) power tool.

SAVE THESE SAFETY INSTRUCTIONS.

7. If devices are provided for the connection of dust extraction and collection facilities, ensure these are connected and properly used. Use of dust collection can reduce dust-related hazards.

POWER TOOL USE AND CARE

1. Do not force the power tool. Use the correct power tool for your application. The correct power tool will do the job better and safer at the rate for which it was designed.

2. Do not use the power tool if the switch does not turn it on and off. Any power tool that cannot be controlled with the switch is dangerous and must be repaired.

3. Disconnect the plug from the power source and/or the battery pack from the power tool before making any adjustments, changing accessories, or storing power tools. Such preventive safety measures reduce the risk of starting the power tool accidentally.

4. Store idle power tools out of the reach of children and do not allow persons unfamiliar with the power tool or these instructions to operate the power tool. Power tools are dangerous in the hands of untrained users.

5. Maintain power tools. Check for misalignment or binding of moving parts, breakage of parts and any other condition that may affect the power tool's operation. If damaged, have the power tool repaired before use. Many accidents are caused by poorly maintained power tools.

6. Keep cutting tools sharp and clean. Properly maintained cutting tools with sharp cutting edges are less likely to bind and are easier to control.

7. Use the power tool, accessories and tool bits, etc. in accordance with these instructions, taking into account the working conditions and the work to be performed. Use of the power tool for operations different from those intended could result in a hazardous situation.

8. Use clamps to secure your workpiece to a stable surface. Holding a workpiece by hand or using your body to support it may lead to loss of control.

9. KEEP GUARDS IN PLACE and in working order.

SERVICE

1. Have your power tool serviced by a qualified repair person using only identical replacement parts. This will ensure that the safety of the power tool is maintained.

CALIFORNIA PROPOSITION 65 WARNING

Some dust created by power sanding, sawing, grinding, drilling, and other construction activities may contain chemicals, including lead, known to the State of California to cause cancer, birth defects, or other reproductive harm. Wash hands after handling. Some examples of these chemicals are:

- Lead from lead-based paints.
- Crystalline silica from bricks, cement, and other masonry products.
- Arsenic and chromium from chemically treated lumber.

Your risk from these exposures varies depending on how often you do this type of work. To reduce your exposure to these chemicals, work in a well-ventilated area with approved safety equipment such as dust masks specially designed to filter out microscopic particles.

CHOP SAW SAFETY WARNINGS

 **WARNING!** Do not let comfort or familiarity with the product replace strict adherence to product safety rules. Failure to follow the safety instructions may result in serious personal injury.

SAW BLADE SAFETY

1. Always wear protective gloves when handling saw blades.
2. Only use blades with correct size and type for both your saw and your workpiece.
 - The rated diameter of the saw blade is 12" with a 1" arbor.
 - The no-load speed of the miter saw is 3800 RPM. The maximum permissible speed of your saw blade should always be higher than the no-load rotational speed of the saw.
3. Never use damaged or deformed saw blades. Only use sharp blades.
4. Install the saw blade in the correct orientation indicated in the instructions.
5. Keep hands out of path of saw blade. Never use your hands to remove sawdust, chips or workpiece near the saw blade or the cutting path of the saw.
6. Never reach around saw blade or reach in back of the saw blade.
7. Do not use blades made from high-speed steel, abrasive blades, metal-cutting blades or masonry-cutting blades. The guards of this saw are not designed to protect against the failure of such blades.
8. The use of accessories or attachments not recommended by the manufacturer may result in a risk of personal injury.
3. People with pacemakers should consult their physician(s) before use. Electromagnetic fields in close proximity to pacemakers could cause pacemaker interference or pacemaker failure.
4. Wear work gloves when handling saw blades. **DO NOT** wear gloves while operating the saw.
5. Sawdust is harmful to your health. Use NIOSH-approved dust masks or other respiratory protection during operation and cleaning.
6. Always turn off and unplug the saw before making any adjustments or repair tasks. Never adjust the saw or the workpiece while the saw is running.
7. The lock down pin is to be used only to lock the head in place for carrying and storage. It is not to be used for any cutting operation.
8. Never use damaged or incorrect blade flanges or bolt. The blade flanges and bolt were specially designed for your saw, for optimum performance and safety of operation.
9. Do not use to cut metal, logs, tree limbs, or uneven lumber.
10. Wet lumber, green (unseasoned) lumber, and pressure treated lumber all have an increased potential for kickback and should only be cut with a blade specifically designed for that lumber type. Wear a NIOSH-approved respirator and have appropriate ventilation whenever cutting pressure treated lumber.

PERSONAL SAFETY

1. Operate in a well ventilated area. Keep the floor area around the saw level and free of slippery substances or other tripping hazards.
2. Wear ANSI-approved safety goggles to protect your eyes from sparks and saw dust. Use hearing protection to protect yourself from hearing loss.

PREPARING THE CHOP SAW

1. When transporting the saw, carry it by either the carrying handle or the base. Never carry the device by its guards or its accessories. Make sure that the lower part of the saw blade is covered by the blade guard during transportation.
2. Securely bolt the saw onto a stand or a workbench before operating.

CHOP SAW SAFETY WARNINGS

 **WARNING!** Do not let comfort or familiarity with the product replace strict adherence to product safety rules. Failure to follow the safety instructions may result in serious personal injury.

3. Examine the saw for any damaged or missing parts. Replace or repair damaged parts before operation. Periodically check that all nuts, bolts and other fasteners are properly tightened.

SECURE YOUR WORKPIECE

1. Always position the workpiece on the table and firmly against the fence. Use the included hold-down clamp to secure the workpiece. Never perform any operation free-hand.

2. Use a clamp or other securing methods to support the workpiece whenever possible.

3. When cutting round workpieces, use clamps on both sides of the table to prevent the workpiece from turning. Position the convex (curved) side against the fence.

4. Always support long workpieces properly using stands or roller tables.

5. Never hand-hold a workpiece that is too small to be clamped, as it can be launched away and cause injury. Use proper support and guides to secure the small workpiece.

DURING CUTTING OPERATIONS

1. Make sure the path of the saw blade is clear of obstruction. Before turning on the saw, do a dry run and make sure that the saw blade does not touch anything other than the workpiece during its entire line of travel.

2. Always stand to one side when operating the saw. Never have any part of the body in line with the path of the saw.

3. Feed work into a blade against the direction of rotation of the blade only.

4. Do not use the saw unless all guards are in place. Do not operate with any guard disabled, damaged, or removed. Moving guards must move freely and close instantly.

5. Turn on the saw and let it reach full speed, then slowly lower the saw into the workpiece. This will help produce safer and cleaner cuts.

6. During slide cutting, always push the saw blade away from you. Do not pull the saw towards you.

7. Never cut more than one piece at a time. Do not stack workpieces together.

8. Turn off tool and wait for saw blade to stop before moving workpiece or changing settings. Do not slow or stop a blade with a piece of wood. Let the blade come to rest naturally. Do not attempt to free a jammed blade while the machine is still running.

9. To reduce risk of injury, return carriage to the full rear position after each crosscut operation.

These safety instructions can't possibly warn of every scenario that may arise with this tool, always make sure to stay alert and use common sense during operation.

ELECTRICAL INFORMATION

GROUNDING INSTRUCTIONS

In the event of a malfunction or breakdown, grounding provides the path of least resistance for an electric current and reduces the risk of electric shock. This tool is equipped with an electric cord that has an equipment grounding conductor and a grounding plug. The plug **MUST** be plugged into a matching outlet that is properly installed and grounded in accordance with ALL local codes and ordinances.

1. Do not modify the plug provided. If it will not fit the outlet, have the proper outlet installed by a licensed electrician.

2. Improper connection of the equipment grounding conductor can result in electric shock. The conductor with the green insulation (with or without yellow stripes) is the equipment grounding conductor. If repair or replacement of the electric cord or plug is necessary, **DO NOT** connect the equipment grounding conductor to a live terminal.

3. Check with a licensed electrician or service personnel if you do not completely understand the grounding instructions or whether the tool is properly grounded.

4. Use only three-wire extension cords that have three-pronged plugs and outlets that accept the tool's plug. Repair or replace a damaged or worn cord immediately.

CAUTION! In all cases, make certain the outlet in question is properly grounded. If you are not sure, have a licensed electrician check the outlet.

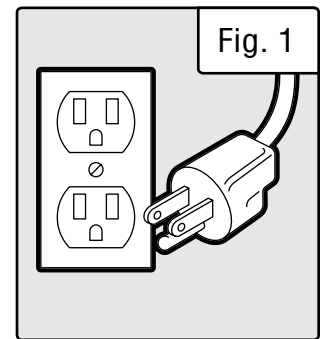

GUIDELINES AND RECOMMENDATIONS FOR EXTENSION CORDS

When using an extension cord, be sure to use one heavy enough to carry the current your product will draw. An undersized cord will cause a drop in line voltage resulting in loss of power and overheating. The table below shows the correct size to be used according to cord length and ampere rating. When in doubt, use a heavier cord. The smaller the gauge number, the heavier the cord.

AMPERAGE	REQUIRED GAUGE FOR EXTENSION CORDS			
	25 ft.	50 ft.	100 ft.	150 ft.
15A	14 gauge	12 gauge	Not Recommended	Not Recommended

1. Examine extension cord before use. Make sure your extension cord is properly wired and in good condition. Always replace a damaged extension cord or have it repaired by a qualified person before using it.

2. Do not abuse extension cord. Do not pull on cord to disconnect from receptacle; always disconnect by pulling on plug. Disconnect the extension cord from the receptacle before disconnecting the product from the extension cord. Protect your extension cords from sharp objects, excessive heat and damp/wet areas.

3. Use a separate electrical circuit for your tool. This circuit must not be less than a 12-gauge wire and should be protected with a 15A time-delayed fuse. Before connecting the motor to the power line, make sure the switch is in the OFF position and the electric current is rated the same as the current stamped on the motor nameplate. Running at a lower voltage will damage the motor.

UNPACKING & PACKING LIST

UNPACKING

With the help of a friend or trustworthy foe, such as one of your in-laws, carefully remove the chop saw from the packaging and place it on a sturdy, flat surface. Make sure to take out all contents and accessories. Do not discard the packaging until everything is removed. Check the packing list below to make sure you have all of the parts and accessories. If any part is missing or broken, please contact customer service at **1-800-232-1195** (M-F 8-5 CST), or email techsupport@wenproducts.com.

PACKING LIST

Components

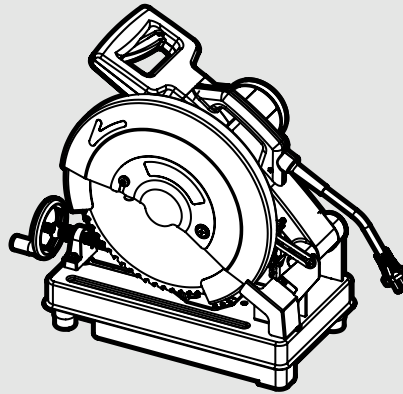

Chop Saw

Accessories

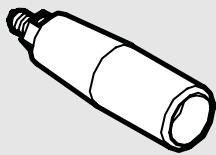

Crank Handle Knob (1)

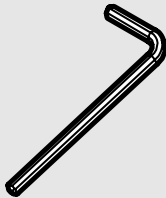

8mm Hex Wrench (1)

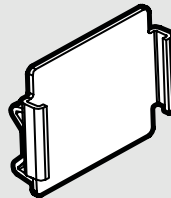

V-Vis Cover (1)

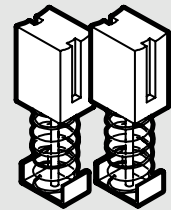

Carbon Brush Replacements (2)

KNOW YOUR CHOP SAW

TOOL PURPOSE

Chop saws allow you to easily cut through metals and other various materials quick and easily. Refer to the following diagrams to become familiarized with all the parts and controls of your chop saw. The components will be referred to later in the manual for assembly and operation instructions.

CHOP SAW

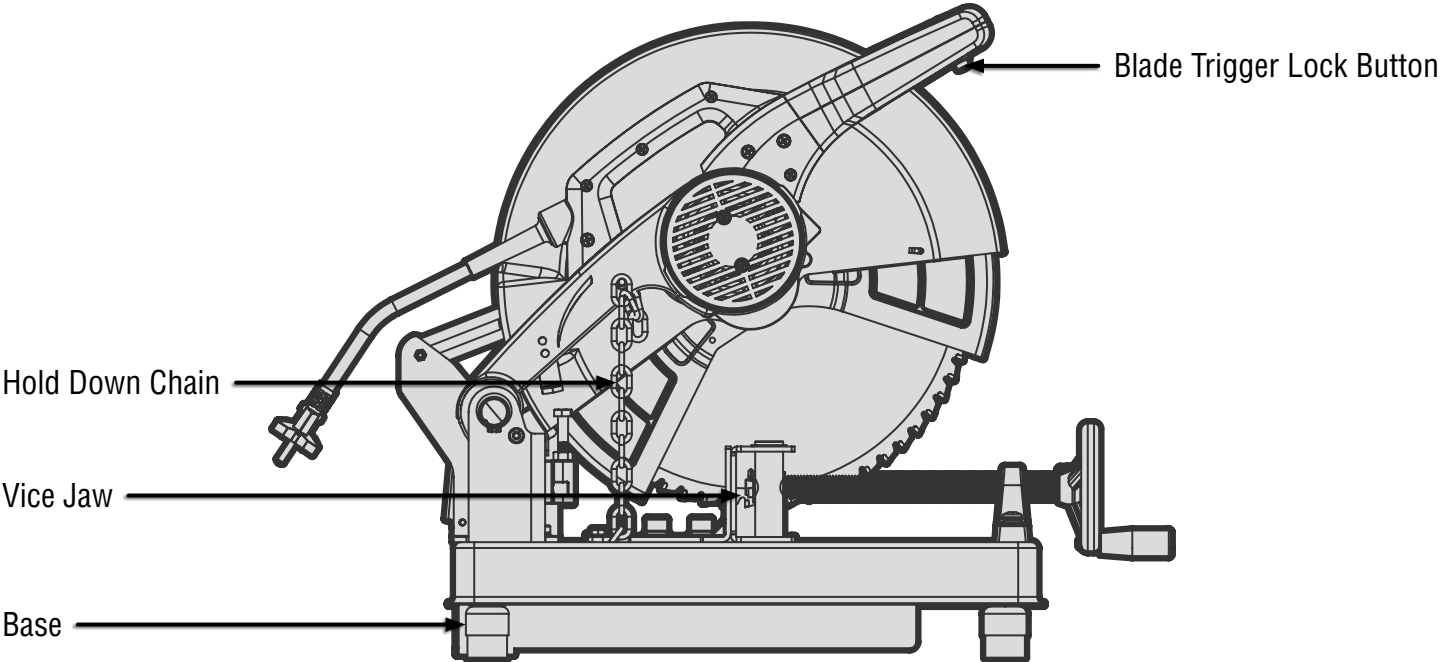
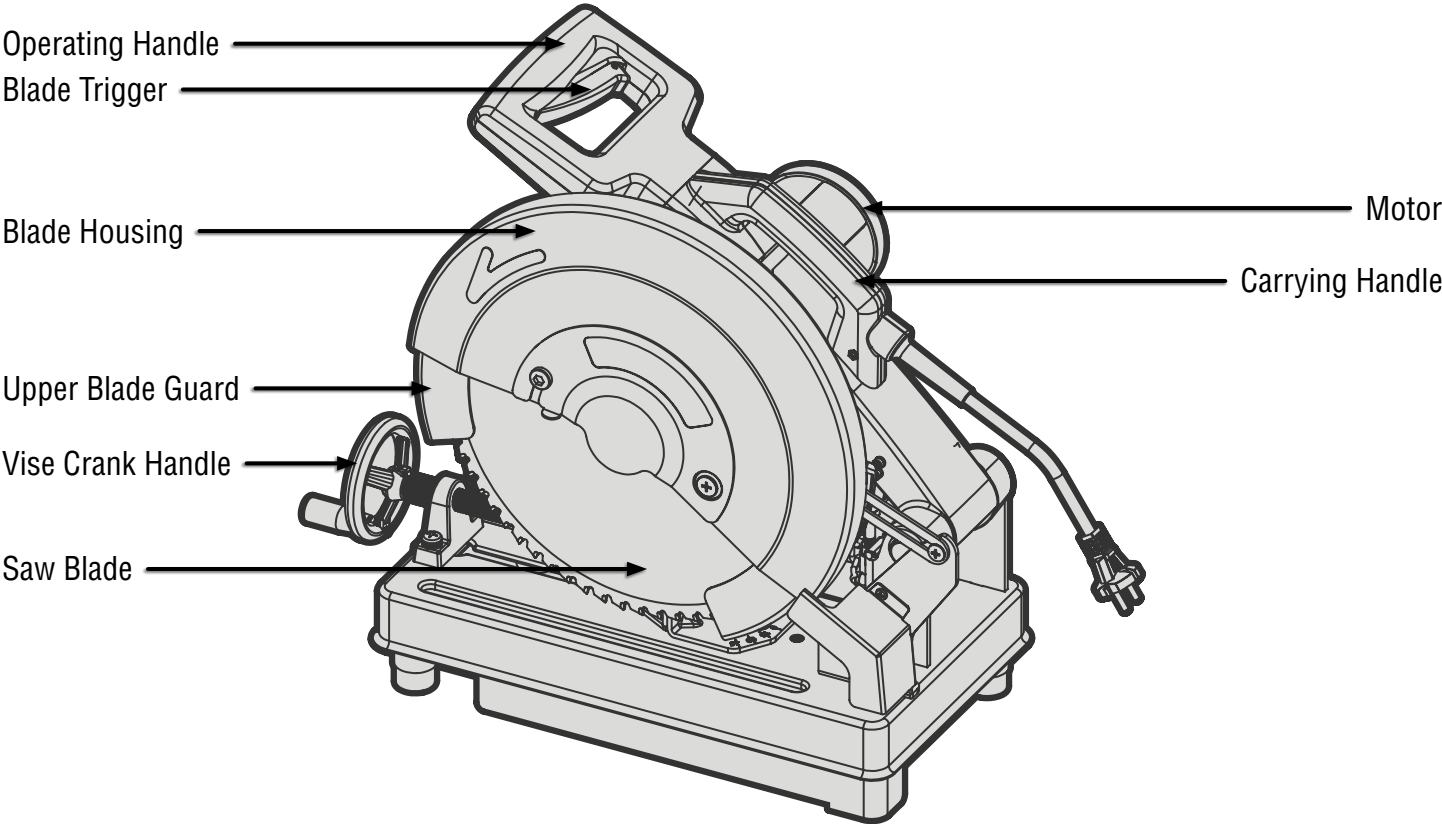

ASSEMBLY & ADJUSTMENTS

⚠ WARNING! Do not plug in or turn on the tool until it is fully assembled according to the instructions. Read through and become familiarized with the following procedures of handling and adjusting your chop saw. Failure to follow the safety instructions may result in serious personal injury.

GUARD OPERATION

NOTE: Keep hands clear of the blade when the operating handle is lowered (Fig. 2 - 1). Do not interfere with the proper movement of the blade guard (Fig. 2 - 2).

When the handle is lowered, the blade guard raises automatically. **When the handle is raised**, the blade guard returns to its safety position, covering the blade.

PLUNGE LOCK

To unlock the saw from the plunged position, unhook the chain (Fig. 3 - 1) from the plunge rod on the left side of the saw arm. To lock the saw in the plunged position, hook the chain on the plunge rod in the tightest position possible to ensure the arm is secured.

ADJUSTING THE CUTTING ANGLE

The rear vise fence can be adjusted to allow for cutting larger work pieces or cutting at varied angles (between 0° and 45°).

To change the angle of the fence:

1. Loosen the two M10 bolts (Fig. 4 - 1) securing the fence to the base.
2. Turn the fence (Fig. 4 - 2) to the desired angle.
3. Tighten the two M10 bolts to lock the fence into place.

To reposition the fence:

1. Loosen and remove the two M10 bolts (Fig. 4 - 1) securing the fence (Fig. 4 - 2) to the base along with the washers on those bolts.
2. Move the fence (Fig. 4 - 2) to the new desired location. There are two different locations that the fence can be fastened in, choose the position that is best for your work piece size.
3. Replace the two M10 bolts (Fig. 4 - 1) along with their washers, making sure that the washers are in the same order as originally assembled.

⚠ WARNING! Be sure the fence is securely in place before making any cuts with the saw. Failure to do so can cause the fence to move during the cut, which could result in serious personal injury.

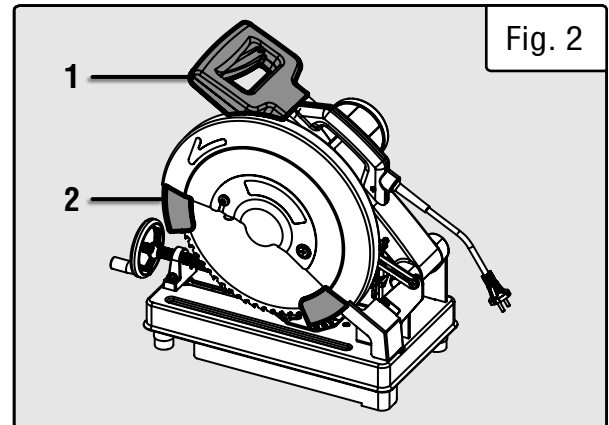

Fig. 2

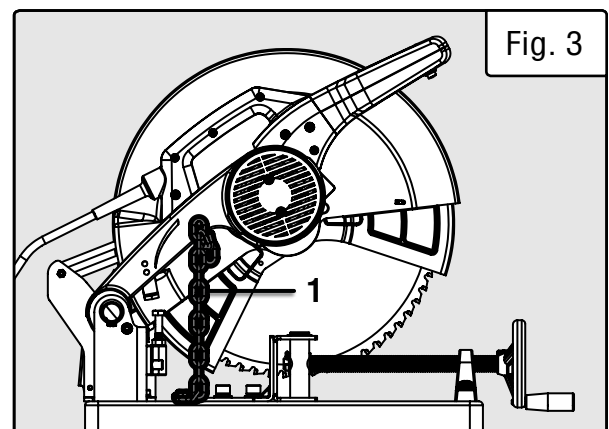

Fig. 3

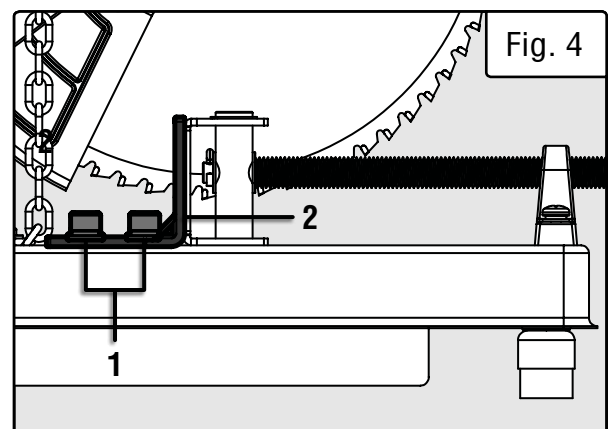

Fig. 4

ASSEMBLY & ADJUSTMENTS

⚠ WARNING! Do not plug in or turn on the tool until it is fully assembled according to the instructions. Read through and become familiarized with the following procedures of handling and adjusting your chop saw. Failure to follow the safety instructions may result in serious personal injury.

V-VISE ATTACHMENT

Your chop saw comes with a V-vise attachment (Fig. 5 - 1) to help cut a wide range of materials safely. The V-vise should be used to get a better grip on round stock or to hold square tube in the proper cutting position. To assemble the V-vise, slide it over the vise jaw (Fig. 6 - 2).

NOTE: Refer to Fig. 11 for the proper cutting orientations for a variety of material shapes.

ADJUSTING THE CUTTING DEPTH

The saw cutting depth can be adjusted if you would like to perform a kerfing or rabbet cut that does not cut all the way through the workpiece.

⚠ WARNING! When adjusting the cutting depth, make sure that the blade does not interfere with the base of the unit before operating the tool or performing any cuts.

1. Unplug the tool from its power source and raise the saw head assembly.
2. Locate the depth stop screw (Fig. 6 - 1) on the left side of your saw.
3. Pull down on the saw head to check the current setting. To change the setting, continue to step 4.
4. Loosen the depth stop nut (Fig. 6 - 2) to allow the depth stop bolt to be adjusted. **To decrease the cutting depth**, turn the depth stop bolt counterclockwise. **To increase the cutting depth**, turn the depth stop bolt clockwise. Tighten the nut after adjustment.
5. Check the cutting depth setting by completing a test cut on a piece of scrap wood. Repeat steps 4-5 until the desired depth is achieved.

CHANGING THE SAW BLADE

To remove the blade:

1. Unplug the tool from its power source.
2. Make sure that the saw blade is in its upper position.
3. Loosen the screw (Fig. 7 - 1) that secures the arbor cover plate and rotate the cover plate up and over to reveal the arbor bolt and outer flange.

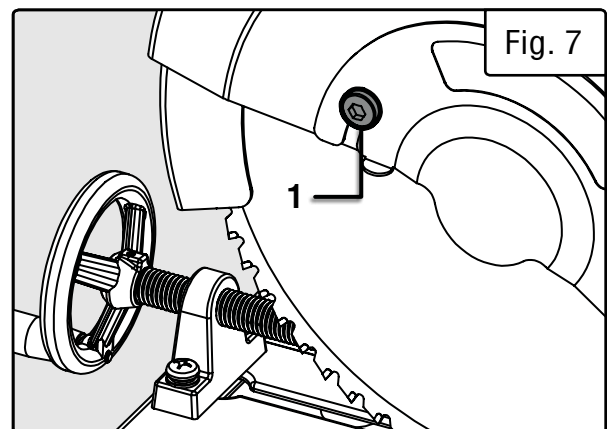
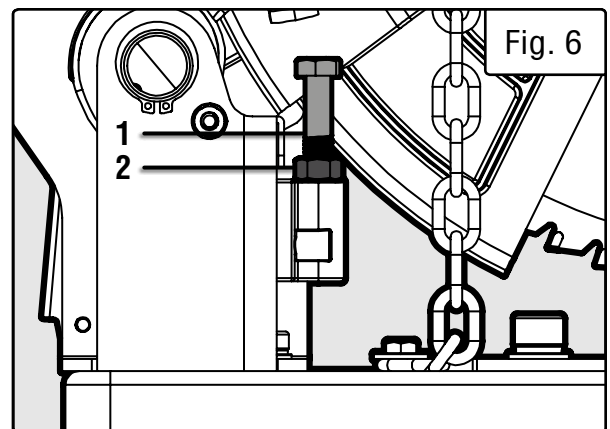
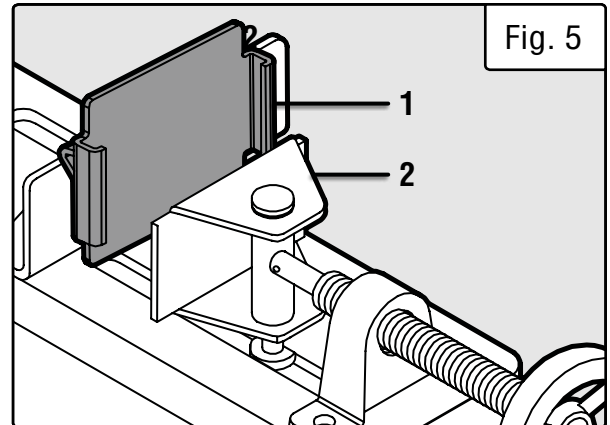

⚠ DANGER! Never try to use a blade larger or thicker than the stated capacity of the saw. Check to make sure that your place is suitable for the intended cutting operation.

ASSEMBLY & ADJUSTMENTS

⚠ WARNING! Do not plug in or turn on the tool until it is fully assembled according to the instructions. Read through and become familiarized with the following procedures of handling and adjusting your chop saw. Failure to follow the safety instructions may result in serious personal injury.

CHANGING THE SAW BLADE (CONT.)

To remove the blade:

4. Lock the arbor by pushing down on the arbor lock (Fig. 8 - 1).
5. Use included 8 mm hex wrench (Fig. 9 - 1) to loosen (turn counterclockwise) and remove the arbor screw, washer, and outer flange (Fig. 9 - 2).
6. Rotate and retract the upper blade guard (Fig. 10 - 1) into the blade housing by hand.
7. Carefully remove blade guard from the blade guard housing.

To install the blade:

1. Check to make sure that all packaging is removed from the new blade and that the blade housing is free from debris and cutting remnants.
2. Install the blade on the inner flange and arbor. Ensure that the blade direction matches the direction on the blade housing (Fig. 10 - 2).
3. Lock the arbor by pushing down on the arbor lock.
4. Reassemble the outer flange, washer, and arbor bolt. Tighten the bolt with the 8 mm hex wrench. Turn the bolt clockwise to tighten.
5. Release the arbor lock and turn the blade gently to ensure that the arbor lock has been disengaged.
6. Rotate the arbor cover into place and tighten the cross head screw to secure the arbor cover.
7. Plunge the saw a few times without the saw being plugged in to ensure that the blade guards operate properly and that the saw is installed properly.

⚠ WARNING! Run the saw for a few minutes after a new blade is installed before cutting any material. This will help to make sure that the blade is installed correctly and that there are no flaws in the blade.

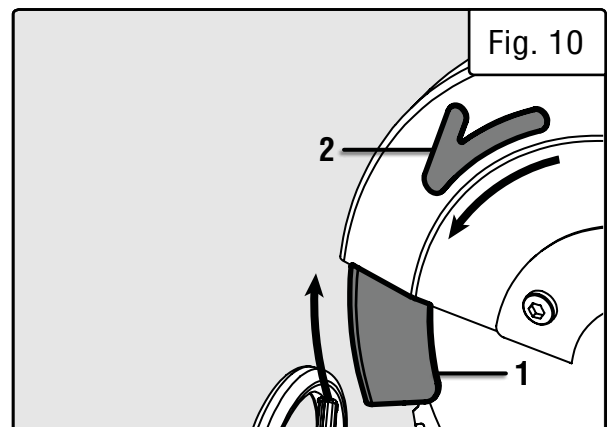
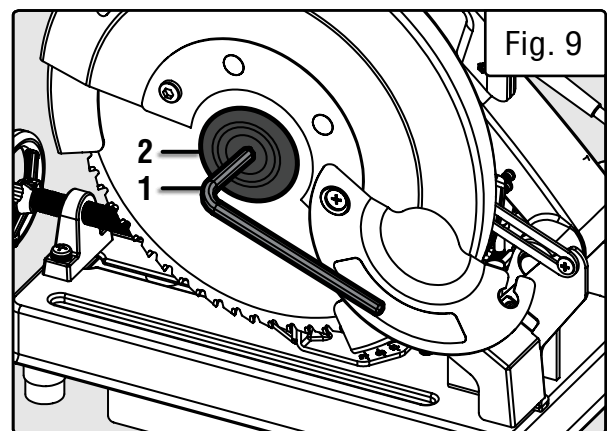
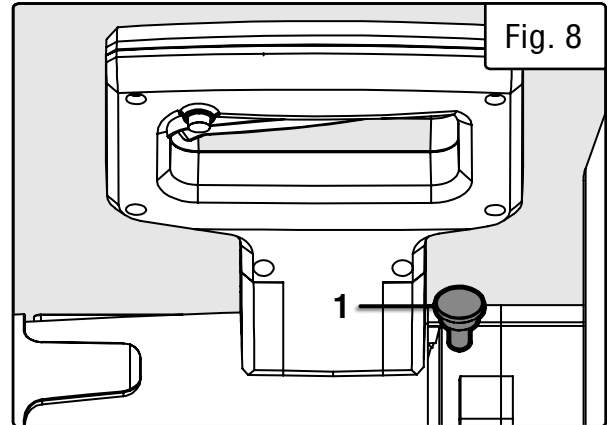

OPERATION

⚠ WARNING! Before operating the miter saw, make sure to equip yourself with a dust mask, ear protection, and safety glasses for protection from possible injuries. Tie back long hair and do not wear loose clothing or jewelry. Do not wear gloves while operating the saw.

1. RAISE THE SAW ARM

Before operation, raise the saw arm from the lower position. See section titled, “Guard Operation” on page 11.

2. SET UP THE CUT ANGLE & DEPTH

The chop saw can be set up to create straight or angled cuts. To adjust the miter angle of the cut, refer to “Adjusting the Miter Angle” on page 11. To adjust the cutting depth, refer to the section titled “Adjusting the Cutting Depth”.

3. SET UP WORKPIECE

Place work piece flat on the base with one edge securely against back fence. If work piece is especially long, be sure to use a roller stand or other work support system to support work piece so it does not damage blade or saw. The WEN **MSA658** Rolling Tool Stand can be a great addition to your shop if you do not have a support system already.

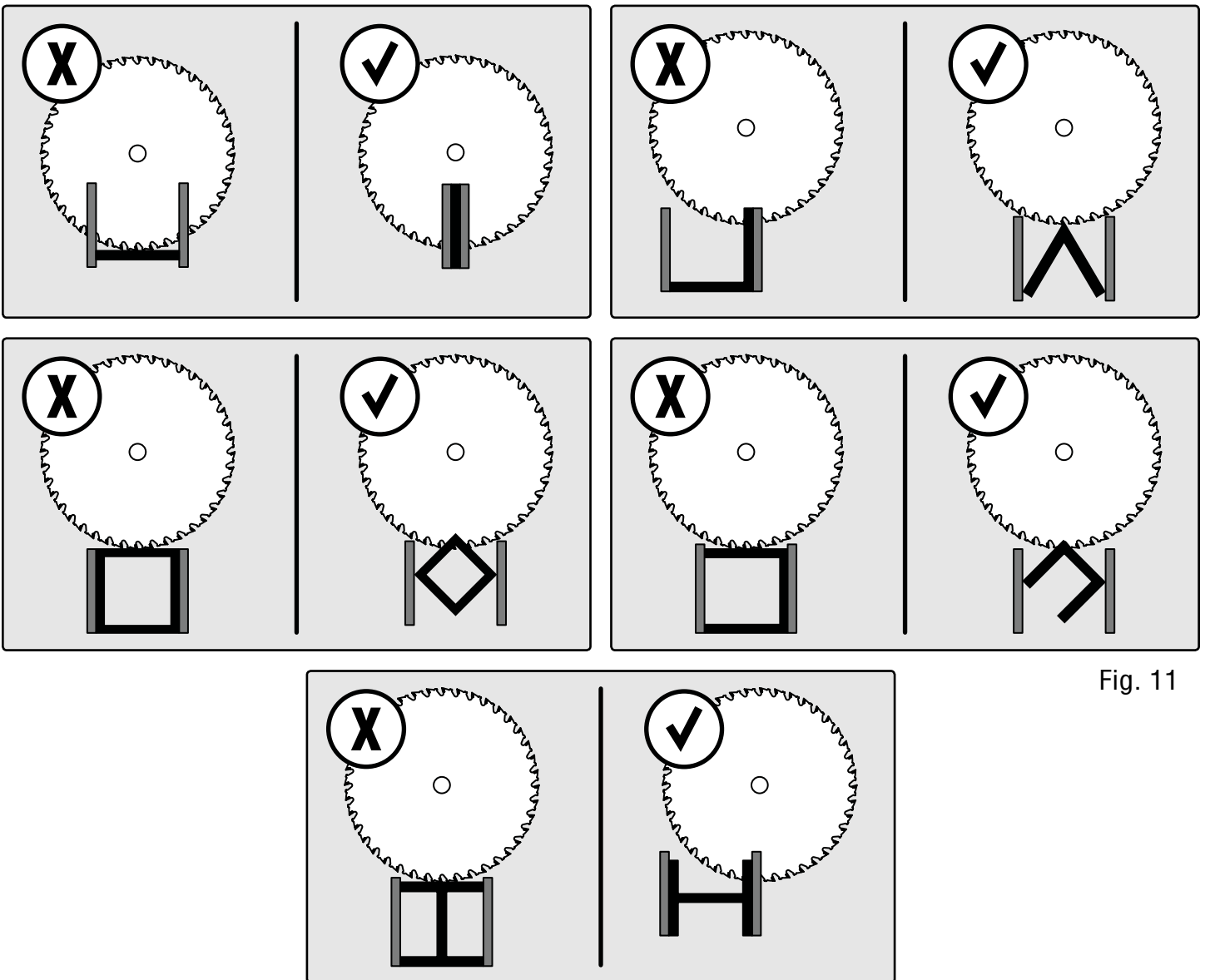

Fig. 11

OPERATION

Material	Cutting Capacity
Mild Steel Plate (Optimal Thickness)	0.25"
Mild Steel Plate (Max Cutting Thickness)	0.5"
Square Tube at 90° (Mild Steel)	4.75" x 4.75"
Square Tube at 45° (Mild Steel)	3.5" x 3.5"
Rectangle Tube at 90° (Mild Steel)	3.75" x 7.25"
Rectangle Tube at 45° (Mild Steel)	3.125" x 4.375"
Round Tube at 90° (Mild Steel)	5.125"
Round Tube at 45° (Mild Steel)	4.125"
Wood at 90° (Nominal Size)	4" x 8" (Actual: 3.5" x 7.25")
Wood at 45° (Nominal Size)	4" x 6" (Actual: 3.5" x 5.5")

4. SECURE WORKPIECE

Secure the work piece with the vise whenever possible to prevent the material from moving during the cutting operation. Refer to Fig. 11 when deciding how to align your work piece for the cut.

5. CHECK BEFORE OPERATION

- Check that the workpiece is fully supported, against the fence and securely clamped.
- Check that you have the proper blade for the material you are cutting.
- Without turning on the saw, perform a dry run of cutting operation to check that nothing is obstructing the path of the saw.

6. PERFORM THE CUT

1. Plug in the chop saw.
2. Grip the operating handle firmly, press the blade trigger lock button (Fig. 12 - 1) with your thumb, and squeeze the power trigger (Fig. 13 - 1) to turn the saw ON.

NOTE: The trigger lock is a safety feature that prevents the power trigger from being pressed down to reduce the risk of accidentally starting the machine.

3. Allow the blade to reach full speed. Make sure the workpiece is held securely against the base and fence at all times. If the material binds to the blade, release the power trigger. Slowly lower the blade into and through the workpiece.

4. Once the work piece has been cut, allow the blade to raise to its upright position. Release the power trigger and wait until the blade fully stops before removing the work piece from the saw.

5. Unplug the chop saw before leaving your work station. Clean your work station and store tools out of reach of children.

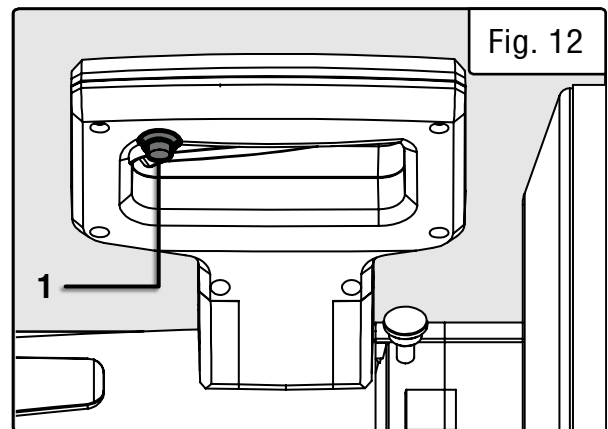

Fig. 12

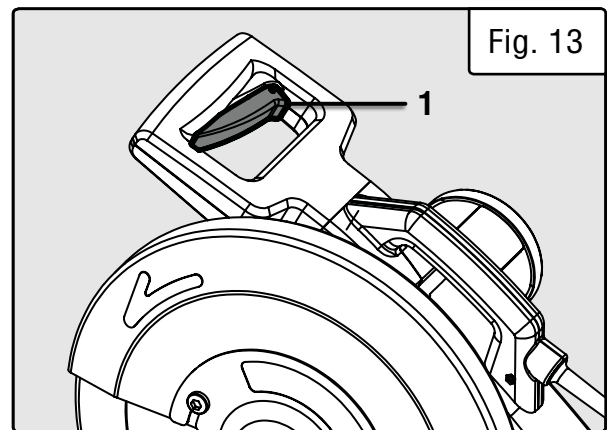

Fig. 13

MAINTENANCE

⚠ WARNING! To avoid accidents, turn OFF and unplug the tool from the electrical outlet before cleaning, adjusting, or performing any maintenance work.

⚠ WARNING! Any attempt to repair or replace electrical parts on this tool may be hazardous. Servicing of the tool must be performed by a qualified technician. When servicing, use only identical WEN replacement parts. Use of other parts may be hazardous or induce product failure.

ROUTINE INSPECTION

Before each use, inspect the general condition of the tool. If any of these following conditions exist, do not use until parts are replaced or the sharpener is properly repaired.

Check for:

- Loose hardware,
- Misalignment or binding of moving parts,
- Damaged cord/electrical wiring,
- Cracked or broken parts, and
- Any other condition that may affect its safe operation steady to hold the cutterhead in place.

CLEANING & STORAGE

1. Keep the ventilation openings free from dust and debris to prevent the motor from overheating.
2. Wipe the tool surfaces clean with a clean cloth. Make sure water does not get into the tool.
3. Store the tool in a clean and dry place away from the reach of children. Store in temperatures between 41° to 86°F.
4. Cover the miter saw in order to protect it from dust and moisture. It is preferable to store it in its original packaging with the instruction manual.

CARBON BRUSH REPLACEMENT

Replacement carbon brushes (Part No. CM1452-035) can be ordered at wenproducts.com. Only genuine WEN replacement brushes designed specifically for your tool should be used.

1. To access the carbon brushes, remove the carbon brush cap (Fig. 14 - 1) with a flat-head screwdriver (not included).
2. Carefully remove the old carbon brushes.
3. Install the new carbon brushes. Both carbon brushes should be replaced at the same time. Replace the carbon brush cap.

NOTE: New carbon brushes tend to spark for a few minutes during the first use as they wear down.

PRODUCT DISPOSAL

Used power tools should not be disposed of together with household waste. This product contains electronic components that should be recycled. Please take this product to your local recycling facility for responsible disposal and to minimize its environmental impact.

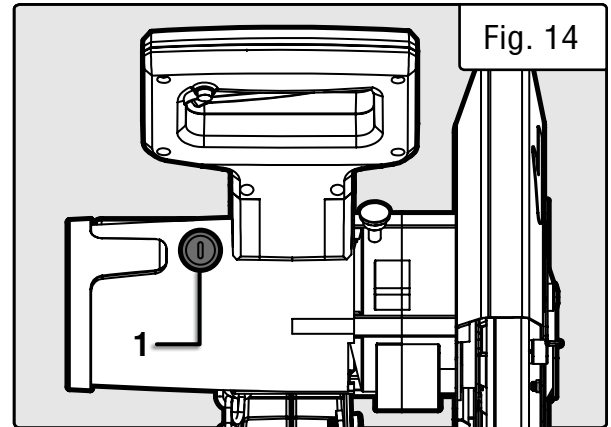

TROUBLESHOOTING GUIDE

⚠ WARNING! Stop using the tool immediately if any of the following problems occur. Repairs and replacements should only be performed by an authorized technician. For any questions, please contact our customer service at **1-(800) 232-1195**, M-F 8-5 CST or email us at **techsupport@wenproducts.com**.

PROBLEM	CAUSE	SOLUTION
Ineffective cutting performance.	Blade is dull.	Sharpen or replace blade.
	Blade is dirty.	Remove the blade and clean the surface and cutting edge with steel wool and turpentine.
	The blade is not secure.	Make sure the blade flanges are flush against the blade and arbor bolt is tightened completely.
	Incorrect blade used for workpiece.	Ensure the blade is compatible with the material type and thickness being cut.
	Blade mounted backwards.	Mount blade in correct orientation.
Excessive noise or vibration.	Damaged saw blade.	Replace blade.
	The blade is not secure.	Make sure the blade flanges are flush against the blade and arbor bolt is tightened completely.
Blade will not turn.	Excessive sawdust or chips between blade and frame.	Clean the space between the blade and frame with compressed air and ensure no chips are stuck within.
	Spindle lock is depressed.	Move the blade back and forth to unlock the spindle lock button.
Motor does not start.	Power cord damaged or not properly plugged in.	Check the power cord, extension cord, power plug and the power outlet. Do not use the tool if any cord is damaged.
	Defective power switch.	Stop using the tool and contact customer service at 1-(800) 232-1195 , M-F 8-5 CST for assistance.
	Insufficient power from power outlet.	Make sure the outlet is functional and is the right capacity for the tool.
	Carbon brushes are worn	Inspect and replace carbon brushes as needed (see page 21) Replacement brushes (Model CM1452-035) can be ordered from wenproducts.com .
	Defective motor or other internal problem	Stop using the tool and contact customer service at 1-(800) 232-1195 , M-F 8-5 CST for assistance.

TROUBLESHOOTING GUIDE

⚠ WARNING! Stop using the tool immediately if any of the following problems occur. Repairs and replacements should only be performed by an authorized technician. For any questions, please contact our customer service at **1-(800) 232-1195**, M-F 8-5 CST or email us at **techsupport@wenproducts.com**.

PROBLEM	CAUSE	SOLUTION
Saw overheats.	Tool forced to work too fast.	Do not force the tool and make sure the workpiece is compatible with the blade in use.
	The extension cord is too long or too thin.	See page 8 for selecting the proper size of extension cord for your tool.
	Blocked motor housing vents.	Blow dust out of the motor housing vents while wearing safety goggles and dust mask.

EXPLODED VIEW & PARTS LIST

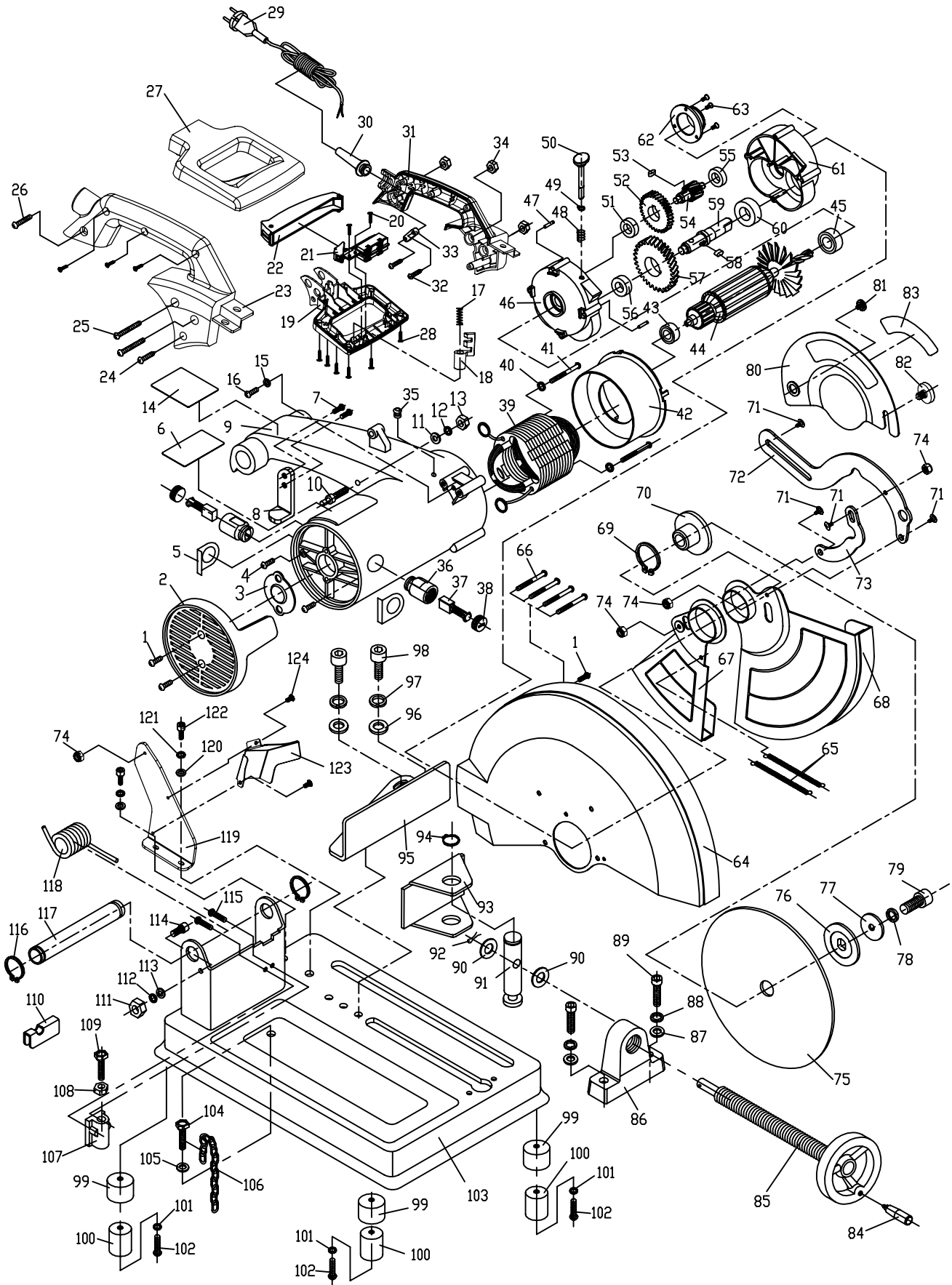

NOTE: Not all parts may be available for purchase.

EXPLODED VIEW & PARTS LIST

No.	Part No.	Description	Qty.	No.	Part No.	Description	Qty.
1	CM1452-001	Screw M5x12	2	39	CM1452-037	Stator	1
2	CM1446-002	Dust Filter	1	40	CM1452-038	Spring Washer 5	2
3	CM1452-003	Bearing Support Plate	1	41	CM1452-039	Screw M5x80	2
4	CM1452-005	Screw M5x10	2	42	CM1452-040	Air Baffle	1
5	CM1452-006	Red Gasket	2	43	CM1452-041	Bearing 6200	1
6	CM1446-006	Label	1	44	CM1452-042	Rotor	1
7	CM1452-008	Bolt M5x15	2	45	CM1452-043	Bearing 6202	1
8	CM1452-009	Depth Stop	1	46	CM1452-044	Inner Gearbox	1
9	CM1452-010	Motor Housing	1	47	CM1452-045	Locating Pin	2
10	CM1446-010	Chain Shaft	1	48	CM1452-046	Stop Pin Spring	1
11	CM1446-011	Flat Washer	1	49	CM1452-047	Split Washer 8	1
12	CM1446-012	Spring Washer 6	1	50	CM1452-048	Arbor Lock	1
13	CM1446-013	Hexagon Nut M6	1	51	CM1452-049	Bearing 6000	1
14	CM1446-014	Warning Sign	1	52	CM1452-050	Gear	1
15	CM1452-012	Washer 5 mm	1	53	CM1452-051	Flat Key 5x12	1
16	CM1452-013	Screw M5x10	1	54	CM1452-052	Small Output Shaft	1
17	CM1452-028	Switch Button Spring	1	55	CM1452-053	Bearing 6200	1
18	CM1452-027	Safety Button	1	56	CM1452-054	Bearing 6001	1
19	CM1452-026	Lower Handle	1	57	CM1452-055	Gear Big	1
20	CM1452-018	Screw ST4.2x13	2	58	CM1452-056	Flat Key 6x12	2
21	CM1452-031	Switch	1	59	CM1452-057	Large Output Shaft	1
22	CM1452-023	Switch Knob	1	60	CM1452-058	Bearing 6204	1
23	CM1452-014	Left Handle	1	61	CM1452-059	Outer Gearbox	1
24	CM1452-015	Screw ST4.2x25	1	62	CM1452-060	Gearshaft Cover	1
25	CM1452-016	Screw M5x60	2	63	CM1452-061	Screw M4x12	3
26	CM1452-017	Screw M5x30	1	64	CM1446-064	Main Blade Guard	1
27	CM1452-029	Upper Handle	1	65	CM1446-065	Tension Spring	2
28	CM1452-025	Screw ST4.2x16	9	66	CM1452-066	Screw M5x90	4
29	CM1452-021	Power Cord	1	67	CM1446-067	Lower Blade Guard	1
30	CM1452-020	Cable Sheath	1	68	CM1446-068	Upper Blade Guard	1
31	CM1452-022	Right Handle	1	69	CM1452-080	Circlip For Shaft	1
32	CM1446-032	Screw ST4.2x15	2	70	CM1452-081	Inner Flange	1
33	CM1452-019	Cable Clamp	1	71	CM1452-077	Screw 4	4
34	CM1452-024	Nut M5	3	72	CM1446-072	Connection Rod 2	1
35	CM1452-033	Protective Ring	1	73	CM1446-073	Connection Rod 1	1
36	CM1452-034	Brush Holder	2	74	CM1446-074	Lock Nut M5	4
37	CM1452-035	Carbon Brush	2	75	BL1466	Blade	1
38	CM1452-036	Brush Cap	2	76	CM1452-092	Outer Flange	1

NOTE: Not all parts may be available for purchase.

EXPLODED VIEW & PARTS LIST

No.	Part No.	Description	Qty.	No.	Part No.	Description	Qty.
77	CM1452-093	Blade Washer	1	101	CM1446-101	Flat Washer 6	3
78	CM1452-094	Spring Washer 10	1	102	CM1446-102	Screw M6x25	3
79	CM1452-095	Bolt M10x30	1	103	CM1446-103	Saw Base	1
80	CM1446-080	Cover Plate	1	104	CM1446-104	Bolt M6x20	1
81	CM1446-081	Positioning Screw	1	105	CM1446-105	Flat Washer 6	1
82	CM1452-090	Blade Cover Screw	1	106	CM1446-106	Plunge Chain	1
83	CM1446-083	Blade Guard Label	1	107	CM1446-107	Depth Stop Holder	1
84	CM1452-096	Crank Handle Knob	1	108	CM1446-108	Nut M8	1
85	CM1452-097	Vise Screw	1	109	CM1446-109	Screw M8x40	1
86	CM1446-086	Vice Screw Support	1	110	CM1446-110	Torsional Spring Foot	1
87	CM1446-087	Flat Washer 8	2	111	CM1446-111	Nut M6	1
88	CM1446-088	Spring Washer 8	2	112	CM1446-112	Spring Washer 6	1
89	CM1446-089	Bolt M8x30	2	113	CM1446-113	Flat Washer 6	1
90	CM1452-102	Flat Washer 8	2	114	CM1446-114	Bolt M6x20	1
91	CM1446-091	Connection Rod 3	1	115	CM1446-115	Screw M5x15	2
92	CM1452-106	Cotter Pin 3x26	1	116	CM1446-116	Circlip For Shaft 24	2
93	CM1446-093	Moving Vise Jaw	1	117	CM1446-117	Axle	1
94	CM1452-108	Circlip For Shaft 22	1	118	CM1446-118	Torsion Spring	1
95	CM1446-095	Back Fence	1	119	CM1446-119	Connection Plate	1
96	CM1452-112	Flat Washer 10	2	120	CM1446-120	Flat Washer 6	2
97	CM1452-113	Spring Washer 10	2	121	CM1446-121	Spring Washer 6	2
98	CM1452-114	Bolt M10x20	2	122	CM1446-122	Bolt M6x25	2
99	CM1446-099	Foot Support	3	123	CM1446-123	Protection Board	1
100	CM1446-100	Rubber Foot	3	124	CM1446-124	Screw M5x8	2

NOTE: Not all parts may be available for purchase.

WARRANTY STATEMENT

WEN Products is committed to building tools that are dependable for years. Our warranties are consistent with this commitment and our dedication to quality.

LIMITED WARRANTY OF WEN PRODUCTS FOR HOME USE

GREAT LAKES TECHNOLOGIES, LLC (“Seller”) warrants to the original purchaser only, that all WEN consumer power tools will be free from defects in material or workmanship during personal use for a period of two (2) years from date of purchase or 500 hours of use; whichever comes first. Ninety days for all WEN products if the tool is used for professional or commercial use. Purchaser has 30 days from the date of purchase to report missing or damaged parts.

SELLER’S SOLE OBLIGATION AND YOUR EXCLUSIVE REMEDY under this Limited Warranty and, to the extent permitted by law, any warranty or condition implied by law, shall be the replacement of parts, without charge, which are defective in material or workmanship and which have not been subjected to misuse, alteration, careless handling, misrepair, abuse, neglect, normal wear and tear, improper maintenance, or other conditions adversely affecting the Product or the component of the Product, whether by accident or intentionally, by persons other than Seller. To make a claim under this Limited Warranty, you must make sure to keep a copy of your proof of purchase that clearly defines the Date of Purchase (month and year) and the Place of Purchase. Place of Purchase must be a direct vendor of Great Lakes Technologies, LLC. Purchasing through third party vendors, including but not limited to garage sales, pawn shops, resale shops, or any other secondhand merchant, voids the warranty included with this product. Contact techsupport@wenproducts.com or 1-800-232-1195 with the following information to make arrangements: your shipping address, phone number, serial number, required part numbers, and proof of purchase. Damaged or defective parts and products may need to be sent to WEN before the replacements can be shipped out.

Upon the confirmation of a WEN representative, your product may qualify for repairs and service work. When returning a product for warranty service, the shipping charges must be prepaid by the purchaser. The product must be shipped in its original container (or an equivalent), properly packed to withstand the hazards of shipment. The product must be fully insured with a copy of the proof of purchase enclosed. There must also be a description of the problem in order to help our repairs department diagnose and fix the issue. Repairs will be made and the product will be returned and shipped back to the purchaser at no charge for addresses within the contiguous United States.

THIS LIMITED WARRANTY DOES NOT APPLY TO ITEMS THAT WEAR OUT FROM REGULAR USAGE OVER TIME, INCLUDING BELTS, BRUSHES, BLADES, BATTERIES, ETC. ANY IMPLIED WARRANTIES SHALL BE LIMITED IN DURATION TO TWO (2) YEARS FROM DATE OF PURCHASE. SOME STATES IN THE U.S. AND SOME CANADIAN PROVINCES DO NOT ALLOW LIMITATIONS ON HOW LONG AN IMPLIED WARRANTY LASTS, SO THE ABOVE LIMITATION MAY NOT APPLY TO YOU.

IN NO EVENT SHALL SELLER BE LIABLE FOR ANY INCIDENTAL OR CONSEQUENTIAL DAMAGES (INCLUDING BUT NOT LIMITED TO LIABILITY FOR LOSS OF PROFITS) ARISING FROM THE SALE OR USE OF THIS PRODUCT. SOME STATES IN THE U.S. AND SOME CANADIAN PROVINCES DO NOT ALLOW THE EXCLUSION OR LIMITATION OF INCIDENTAL OR CONSEQUENTIAL DAMAGES, SO THE ABOVE LIMITATION OR EXCLUSION MAY NOT APPLY TO YOU.

THIS LIMITED WARRANTY GIVES YOU SPECIFIC LEGAL RIGHTS, AND YOU MAY ALSO HAVE OTHER RIGHTS WHICH VARY FROM STATE TO STATE IN THE U.S., PROVINCE TO PROVINCE IN CANADA AND FROM COUNTRY TO COUNTRY.

THIS LIMITED WARRANTY APPLIES ONLY TO ITEMS SOLD WITHIN THE UNITED STATES OF AMERICA, CANADA AND THE COMMONWEALTH OF PUERTO RICO. FOR WARRANTY COVERAGE WITHIN OTHER COUNTRIES, CONTACT THE WEN CUSTOMER SUPPORT LINE. FOR WARRANTY PARTS OR PRODUCTS REPAIRED UNDER WARRANTY SHIPPING TO ADDRESSES OUTSIDE OF THE CONTIGUOUS UNITED STATES, ADDITIONAL SHIPPING CHARGES MAY APPLY.

**THANKS FOR
REMEMBERING**

