



## 2.5-INCH RETRACTABLE WORKBENCH CASTERS (4-PACK)

### SPECIFICATIONS

Model	CA2580
Diameter	2.5 Inches
Capacity	Combined: 600 Pounds (Evenly Distributed)
	Individual: 150 Pounds

### PACKING LIST

#### Components

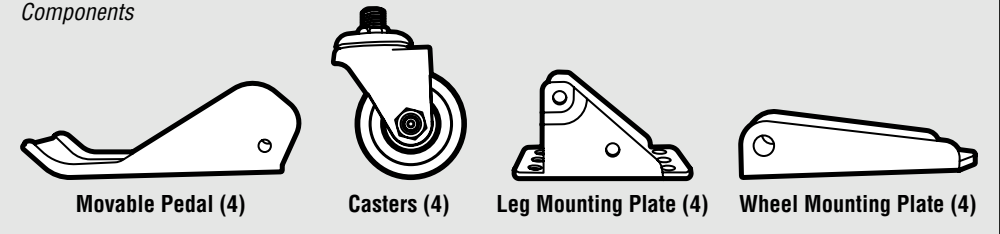

#### Accessories

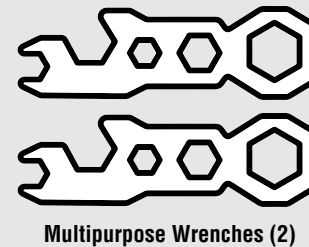

#### Hardware

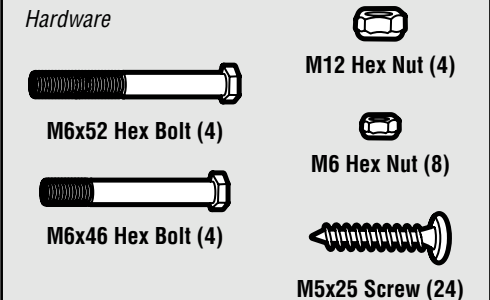

THANKS FOR  
REMEMBERING 

### NEED HELP? CONTACT US!

Have product questions? Need technical support? Please feel free to contact us:

 1-847-429-9263 (M-F 8AM-5PM CST) |  [TECHSUPPORT@WENPRODUCTS.COM](mailto:TECHSUPPORT@WENPRODUCTS.COM)

# INSTRUCTION MANUAL

## ASSEMBLY & ADJUSTMENTS

### ASSEMBLING THE CASTERS

1. Secure the movable pedal, leg mounting plate, and wheel mounting plate together using one M6x52 hex bolt (Fig. 1 - 1) and one M6 hex nut (Fig. 1 - 2) through the lower holes (A), and one M6x46 hex bolt (Fig. 1 - 3) and one M6 hex nut (Fig. 1 - 4) through the upper holes (B). Repeat for the remaining three casters.
2. Secure the mounting assembly to your workbench using six M5x25 screws (Fig. 1 - 5) through each hole on the leg mounting plate (C). Make sure that there is a 1.5 inch clearance between the floor and the bottom of the leg mounting plate. Repeat for the remaining three casters. See figures 2 and 3 for mounting dimensions.

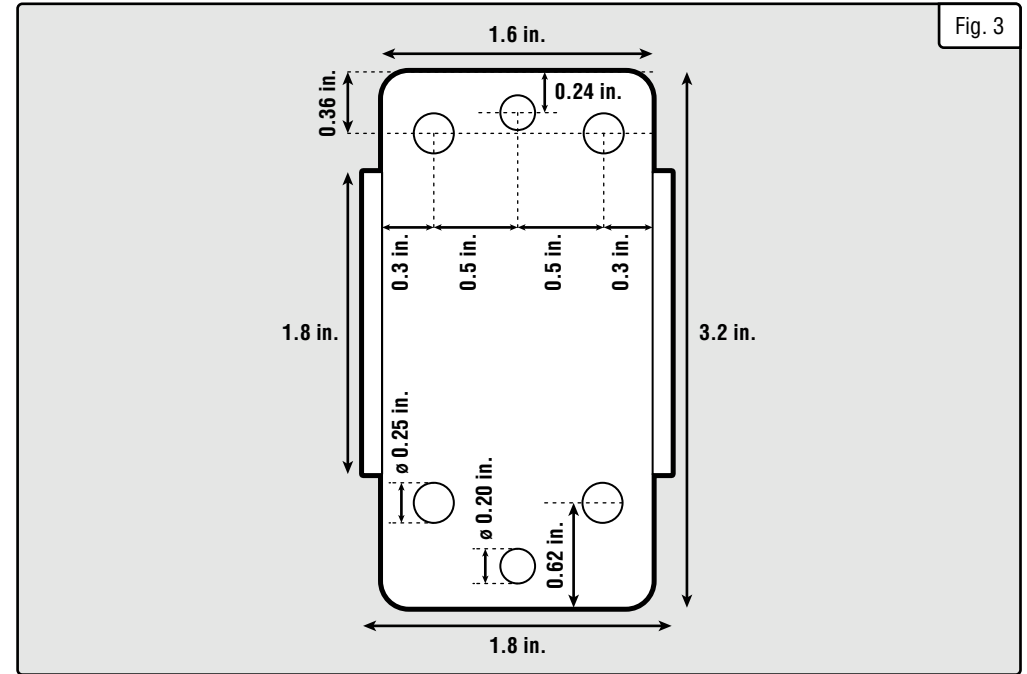
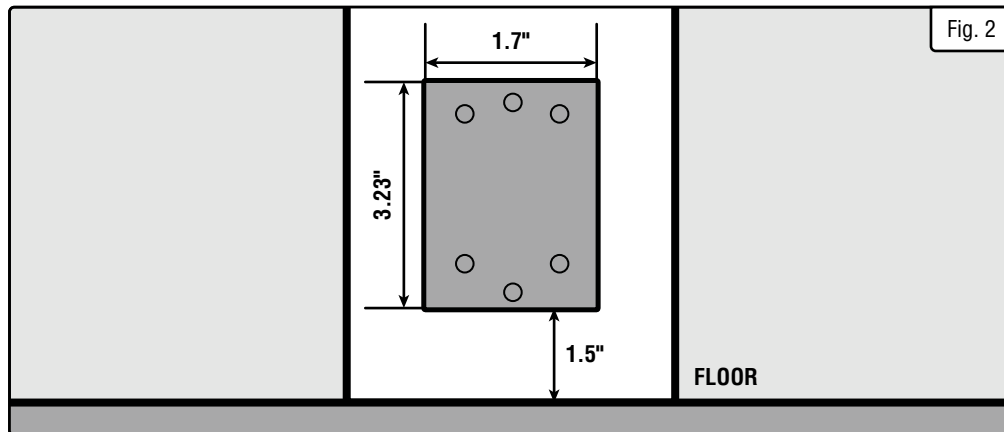
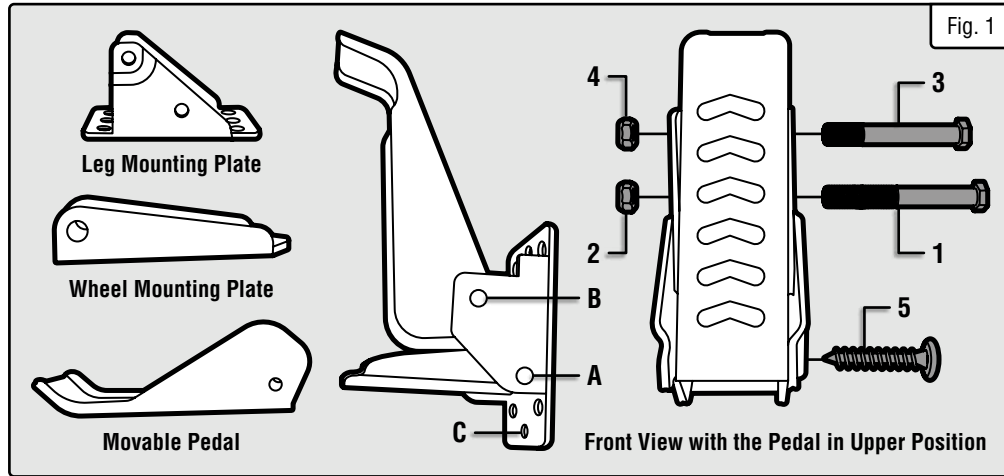

### ASSEMBLY & ADJUSTMENTS

3. Secure the caster (Fig. 4 - 1) to the mounting assembly (Fig. 4 - 2) through the hole in the wheel mounting plate using one M12 hex nut (Fig. 4 - 3). Repeat for the remaining three casters.

