

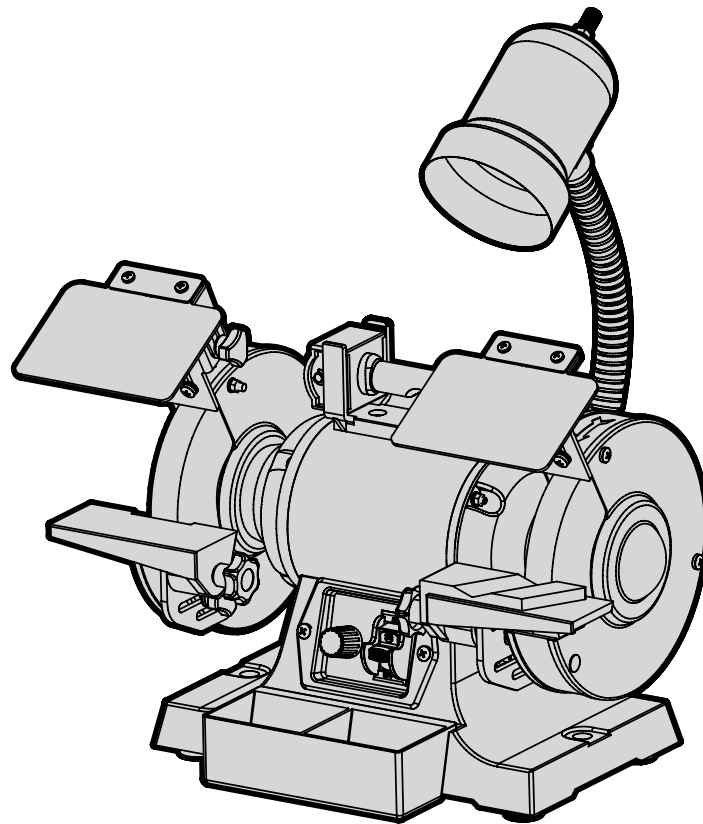

MODEL BG625V

6-INCH VARIABLE SPEED BENCH GRINDER

Instruction Manual



NEED HELP? CONTACT US!

Have product questions? Need technical support? Please feel free to contact us:



1-847-429-9263 (M-F 8AM-5PM CST)



TECHSUPPORT@WENPRODUCTS.COM

IMPORTANT: Your new tool has been engineered and manufactured to WEN's highest standards for dependability, ease of operation, and operator safety. When properly cared for, this product will supply you years of rugged, trouble-free performance. Pay close attention to the rules for safe operation, warnings, and cautions. If you use your tool properly and for its intended purpose, you will enjoy years of safe, reliable service.

For replacement parts and the most up-to-date instruction manuals, visit ***WENPRODUCTS.COM***

CONTENTS

WELCOME	3
Introduction	3
Specifications.....	3
SAFETY	4
General Safety Rules	4
Bench Grinder Safety Warnings	6
Electrical Information.....	8
BEFORE OPERATING	9
Unpacking & Packing List	9
Know Your Bench Grinder.....	10
Assembly & Adjustments.....	11
OPERATION & MAINTENANCE	12
Operation	12
Maintenance.....	13
Troubleshooting Guide.....	15
Exploded View & Parts List.....	16
Warranty Statement	18

To purchase accessories and replacement parts for your tool, visit **WENPRODUCTS.COM**

Cast Iron Bench Grinder Stand (Model 4288T)

6-Inch Wire Wheel (Model WW6012)

36-Grit Grinding Wheel (Model 4276-015)

80-Grit Grinding Wheel (Model BG625V-057)

INTRODUCTION

Thanks for purchasing the WEN Bench Grinder. We know you are excited to put your tool to work, but first, please take a moment to read through the manual. Safe operation of this tool requires that you read and understand this operator's manual and all the labels affixed to the tool. This manual provides information regarding potential safety concerns, as well as helpful assembly and operating instructions for your tool.

 Indicates danger, warning, or caution. The safety symbols and the explanations with them deserve your careful attention and understanding. Always follow the safety precautions to reduce the risk of fire, electric shock or personal injury. However, please note that these instructions and warnings are not substitutes for proper accident prevention measures.

NOTE: The following safety information is not meant to cover all possible conditions and situations that may occur. WEN reserves the right to change this product and specifications at any time without prior notice.

At WEN, we are continuously improving our products. If you find that your tool does not exactly match this manual, please visit wenproducts.com for the most up-to-date manual or contact our customer service at **1-847-429-9263**.

Keep this manual available to all users during the entire life of the tool and review it frequently to maximize safety for both yourself and others.

SPECIFICATIONS

Model Number	BG625V
Motor	120V, 60 Hz, 2.5A
Wheel Speed	2000 - 3400 RPM
Grinding Wheel Size	6 in. x 3/4 in. x 1/2 in.
Arbor Size	1/2 Inch
Arbor Thread	M12-1.75
Wheel Grits	36 Grit and 80 Grit
Product Weight	29.3 Pounds (13.3 kg)
Product Dimensions	5.35 in. x 9.65 in. x 17.32 in.

GENERAL SAFETY RULES

 **WARNING!** Read all safety warnings and all instructions. Failure to follow the warnings and instructions may result in electric shock, fire and/or serious injury.

Safety is a combination of common sense, staying alert and knowing how your item works. The term “power tool” in the warnings refers to your mains-operated (corded) power tool or battery-operated (cordless) power tool.

SAVE THESE SAFETY INSTRUCTIONS.

WORK AREA SAFETY

- 1. Keep work area clean and well lit.** Cluttered or dark areas invite accidents.
- 2. Do not operate power tools in explosive atmospheres, such as in the presence of flammable liquids, gases or dust.** Power tools create sparks which may ignite the dust or fumes.
- 3. Keep children and bystanders away while operating a power tool.** Distractions can cause you to lose control.

ELECTRICAL SAFETY

- 1. Power tool plugs must match the outlet. Never modify the plug in any way. Do not use any adapter plugs with earthed (grounded) power tools.** Unmodified plugs and matching outlets will reduce risk of electric shock.
- 2. Avoid body contact with earthed or grounded surfaces such as pipes, radiators, ranges and refrigerators.** There is an increased risk of electric shock if your body is earthed or grounded.
- 3. Do not expose power tools to rain or wet conditions.** Water entering a power tool will increase the risk of electric shock.
- 4. Do not abuse the cord. Never use the cord for carrying, pulling or unplugging the power tool. Keep cord away from heat, oil, sharp edges or moving parts.** Damaged or entangled cords increase the risk of electric shock.
- 5. When operating a power tool outdoors, use an extension cord suitable for outdoor use.** Use of a cord suitable for outdoor use reduces the risk of electric shock.

6. If operating a power tool in a damp location is unavoidable, use a ground fault circuit interrupter (GFCI) protected supply. Use of a GFCI reduces the risk of electric shock.

PERSONAL SAFETY

- 1. Stay alert, watch what you are doing and use common sense when operating a power tool. Do not use a power tool while you are tired or under the influence of drugs, alcohol or medication.** A moment of inattention while operating power tools may result in serious personal injury.
- 2. Use personal protective equipment. Always wear eye protection.** Protective equipment such as a respiratory mask, non-skid safety shoes and hearing protection used for appropriate conditions will reduce the risk of personal injury.
- 3. Prevent unintentional starting. Ensure the switch is in the off-position before connecting to power source and/or battery pack, picking up or carrying the tool.** Carrying power tools with your finger on the switch or energizing power tools that have the switch on invites accidents.
- 4. Remove any adjusting key or wrench before turning the power tool on.** A wrench or a key left attached to a rotating part of the power tool may result in personal injury.
- 5. Do not overreach. Keep proper footing and balance at all times.** This enables better control of the power tool in unexpected situations.
- 6. Dress properly. Do not wear loose clothing or jewelry. Keep your hair and clothing away from moving parts.** Loose clothes, jewelry or long hair can be caught in moving parts.

GENERAL SAFETY RULES

 **WARNING!** Read all safety warnings and all instructions. Failure to follow the warnings and instructions may result in electric shock, fire and/or serious injury.

Safety is a combination of common sense, staying alert and knowing how your item works. The term “power tool” in the warnings refers to your mains-operated (corded) power tool or battery-operated (cordless) power tool.

SAVE THESE SAFETY INSTRUCTIONS.

7. If devices are provided for the connection of dust extraction and collection facilities, ensure these are connected and properly used. Use of dust collection can reduce dust-related hazards.

POWER TOOL USE AND CARE

1. Do not force the power tool. Use the correct power tool for your application. The correct power tool will do the job better and safer at the rate for which it was designed.

2. Do not use the power tool if the switch does not turn it on and off. Any power tool that cannot be controlled with the switch is dangerous and must be repaired.

3. Disconnect the plug from the power source and/or the battery pack from the power tool before making any adjustments, changing accessories, or storing power tools. Such preventive safety measures reduce the risk of starting the power tool accidentally.

4. Store idle power tools out of the reach of children and do not allow persons unfamiliar with the power tool or these instructions to operate the power tool. Power tools are dangerous in the hands of untrained users.

5. Maintain power tools. Check for misalignment or binding of moving parts, breakage of parts and any other condition that may affect the power tool's operation. If damaged, have the power tool repaired before use. Many accidents are caused by poorly maintained power tools.

6. Keep cutting tools sharp and clean. Properly maintained cutting tools with sharp cutting edges are less likely to bind and are easier to control.

7. Use the power tool, accessories and tool bits, etc. in accordance with these instructions, taking into account the working conditions and the work to be performed. Use of the power tool for operations different from those intended could result in a hazardous situation.

8. Use clamps to secure your workpiece to a stable surface. Holding a workpiece by hand or using your body to support it may lead to loss of control.

9. KEEP GUARDS IN PLACE and in working order.

SERVICE

1. Have your power tool serviced by a qualified repair person using only identical replacement parts. This will ensure that the safety of the power tool is maintained.

CALIFORNIA PROPOSITION 65 WARNING

Some dust created by power sanding, sawing, grinding, drilling, and other construction activities may contain chemicals, including lead, known to the State of California to cause cancer, birth defects, or other reproductive harm. Wash hands after handling. Some examples of these chemicals are:

- Lead from lead-based paints.
- Crystalline silica from bricks, cement, and other masonry products.
- Arsenic and chromium from chemically treated lumber.

Your risk from these exposures varies depending on how often you do this type of work. To reduce your exposure to these chemicals, work in a well-ventilated area with approved safety equipment such as dust masks specially designed to filter out microscopic particles.

BENCH GRINDER SAFETY WARNINGS

 **WARNING!** Do not operate the power tool until you have read and understood the following instructions and the warning labels.

BENCH GRINDER SAFETY

1. This bench grinder is designed for sharpening and honing cutting tools, using the appropriate accessories. Using the machine for any other purpose for which it is not designed may result in serious injuries, machine damage and voiding of the warranty.

2. Grinding wheel safety:

- Only use grinding wheels rated for a speed higher than 3400 RPM (maximum RPM of the tool).
- Inspect wheels for cracks or fragments before starting the machine. Replace damaged wheels immediately. Never use a questionable grinding wheel, as the RPM of the machine can send broken wheel fragments flying at high speeds.
- Do not use a wheel that vibrates. If a wheel vibrates, it may be that the bearings of the shaft need replacing.
- Check that the grinding stone can rotate smoothly before starting the machine.
- The grinding wheel is for grinding. Never attempt to cut anything with the grinding wheel.

3. The use of accessories or attachments not recommended by the manufacturer may result in a risk of personal injury.

4. **DANGER! Fire Hazard.** Do not grind or polish magnesium or magnesium alloys.

5. Preventing accidental starting. Make sure the power switch is in the OFF position prior to plugging in the machine. Always make sure the power switch is in the OFF position and the machine is unplugged when doing any cleaning, adjustments, assembly, setup operations, or when not in use.

PERSONAL SAFETY

1. Operate in a well ventilated area. Keep the floor area around the bench grinder level and free of slippery substances or other tripping hazards.

2. Wear ANSI-approved safety goggles to protect your eyes from sparks and chips. Use hearing protection to protect yourself from hearing loss.

3. DO NOT wear loose clothing or jewelry as they might get drawn in by the tool. Tie back long hair.

4. People with pacemakers should consult their physician(s) before use. Electromagnetic fields in close proximity to pacemakers could cause pacemaker interference or pacemaker failure.

5. Chips are harmful to your health. Use NIOSH-approved dust masks or other respiratory protection during operation and cleaning.

6. Always turn off and unplug the bench grinder before making any adjustments or repair tasks. Never adjust the bench grinder or the workpiece while the tool is running.

PREPARING THE BENCH GRINDER

When transporting the bench grinder, carry it by the base. Never carry the device by its guards or its accessories.

1. Examine the bench grinder for any damaged or missing parts. Replace or repair damaged parts before operation. Periodically check that all nuts, bolts and other fasteners are properly tightened.

2. Do not operate this tool until it is completely assembled and installed according to the instructions. Make sure all adjustments are correct and all connections are tight. Keep all guards in place.

DURING OPERATION

1. Never start the machine with any load already applied to either grinding wheel. Stand to the side of the bench grinder during start-up. Switch it ON and let the bench grinder reach full speed for roughly one minute to warm up the wheel and to ensure proper operation.

2. Never grind on a cold wheel. Run the bench grinder for one full minute before applying the workpiece. Cold wheels have an increased likelihood of chipping during operation.

3. Only grind on the face of the grinding wheel. Do not grind on the side of the wheel.

BENCH GRINDER SAFETY WARNINGS

 **WARNING!** Do not operate the power tool until you have read and understood the following instructions and the warning labels.

DURING OPERATION (CONT.)

4. Keep clear of moving parts. Keep arms, hands and other vital appendages away from the grinding and honing wheel. Do not reach behind or beneath the rotating wheel. Avoid awkward operation and hand positions. An accident could easily send the operator's hand into the wheel.
5. If you are interrupted when operating the bench grinder, complete the process and switch the bench grinder off before looking up.
6. Always hold the workpiece firmly against the tool rest.
7. Never attempt to cut anything with the grinding wheel.
8. Do not use the bench grinder unless all guards are in place. Do not operate with any guard disabled, damaged, or removed. Moving guards must move freely and close instantly.
9. Disconnect the power source and allow the wheels to come to a complete stop before making any adjustments to either the machine or the grinding wheels.
10. Clean the machine thoroughly when changing material types in workpieces. Combining certain materials can increase the chances of an explosion or fire hazard.
11. Should any component of your bench grinder be missing/damaged or fail in any way, shut off the switch and remove the plug from power supply outlet. Have a certified technician replace the missing, damaged, or failed parts using only identical replacement parts before resuming operation.

ELECTRICAL INFORMATION

GROUNDING INSTRUCTIONS

In the event of a malfunction or breakdown, grounding provides the path of least resistance for an electric current and reduces the risk of electric shock. This tool is equipped with an electric cord that has an equipment grounding conductor and a grounding plug. The plug **MUST** be plugged into a matching outlet that is properly installed and grounded in accordance with ALL local codes and ordinances.

1. Do not modify the plug provided. If it will not fit the outlet, have the proper outlet installed by a licensed electrician.

2. Improper connection of the equipment grounding conductor can result in electric shock. The conductor with the green insulation (with or without yellow stripes) is the equipment grounding conductor. If repair or replacement of the electric cord or plug is necessary, **DO NOT** connect the equipment grounding conductor to a live terminal.

3. Check with a licensed electrician or service personnel if you do not completely understand the grounding instructions or whether the tool is properly grounded.

4. Use only three-wire extension cords that have three-pronged plugs and outlets that accept the tool's plug (INSERT CR). Repair or replace a damaged or worn cord immediately.

CAUTION! In all cases, make certain the outlet in question is properly grounded. If you are not sure, have a licensed electrician check the outlet.

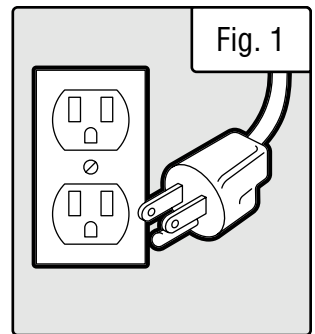

GUIDELINES AND RECOMMENDATIONS FOR EXTENSION CORDS

When using an extension cord, be sure to use one heavy enough to carry the current your product will draw. An undersized cord will cause a drop in line voltage resulting in loss of power and overheating. The table below shows the correct size to be used according to cord length and ampere rating. When in doubt, use a heavier cord. The smaller the gauge number, the heavier the cord.

AMPERAGE	REQUIRED GAUGE FOR EXTENSION CORDS			
	25 ft.	50 ft.	100 ft.	150 ft.
2.5A	18 gauge	16 gauge	16 gauge	14 gauge

1. Examine extension cord before use. Make sure your extension cord is properly wired and in good condition. Always replace a damaged extension cord or have it repaired by a qualified person before using it.

2. Do not abuse extension cord. Do not pull on cord to disconnect from receptacle; always disconnect by pulling on plug. Disconnect the extension cord from the receptacle before disconnecting the product from the extension cord. Protect your extension cords from sharp objects, excessive heat and damp/wet areas.

3. Use a separate electrical circuit for your tool. This circuit must not be less than a 12-gauge wire and should be protected with a 15A time-delayed fuse. Before connecting the motor to the power line, make sure the switch is in the OFF position and the electric current is rated the same as the current stamped on the motor nameplate. Running at a lower voltage will damage the motor.

UNPACKING & PACKING LIST

⚠ WARNING! Do not plug in or turn on the tool until it is fully assembled according to the instructions. Failure to follow the safety instructions may result in serious personal injury.

UNPACKING

With the help of a friend or trustworthy foe, carefully remove the Bench Grinder from the packaging. Make sure to take out all contents and accessories. Do not discard the packaging until everything is removed. Check the packing list below to make sure you have all of the parts and accessories. If any part is missing or broken, please contact our customer service at **1-847-429-9263** (M-F 8-5 CST), or email techsupport@wenproducts.com.

PACKING LIST

Components

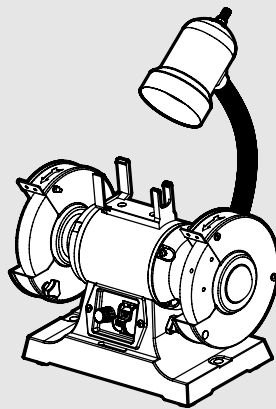

Bench Grinder

Accessories



Left & Right Spark Deflector

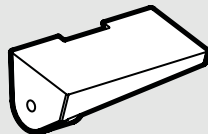

Right Tool Rest

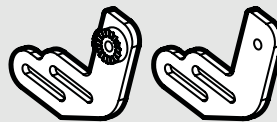

**Right and Left
Tool Rest Support**

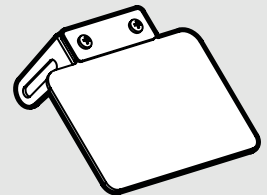

Right Eye Guard

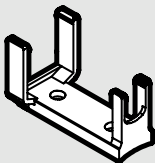

Dresser Mount



Left Tool Rest

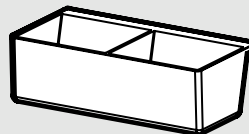

Quenching Tray

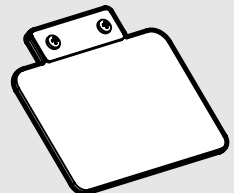

Left Eye Guard

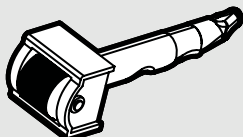

Wheel Dresser

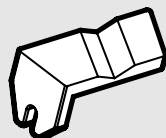

**Drill Bit
Sharpening Rest**

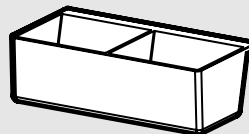

Quenching Tray



**Wire Wheel
Spacer**

**Hardware Bag
(Not Pictured)**

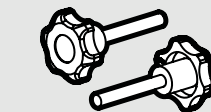

**Tool Rest Support
Lock Knobs**

KNOW YOUR BENCH GRINDER

TOOL PURPOSE

Sharpen bits, drill bits, chisels, gouges, and other cutting tools all with your WEN Bench Grinder. Refer to the following diagrams to become familiarized with all the parts and controls of your bench grinder. The components will be referred to later in the manual for assembly and operation instructions.

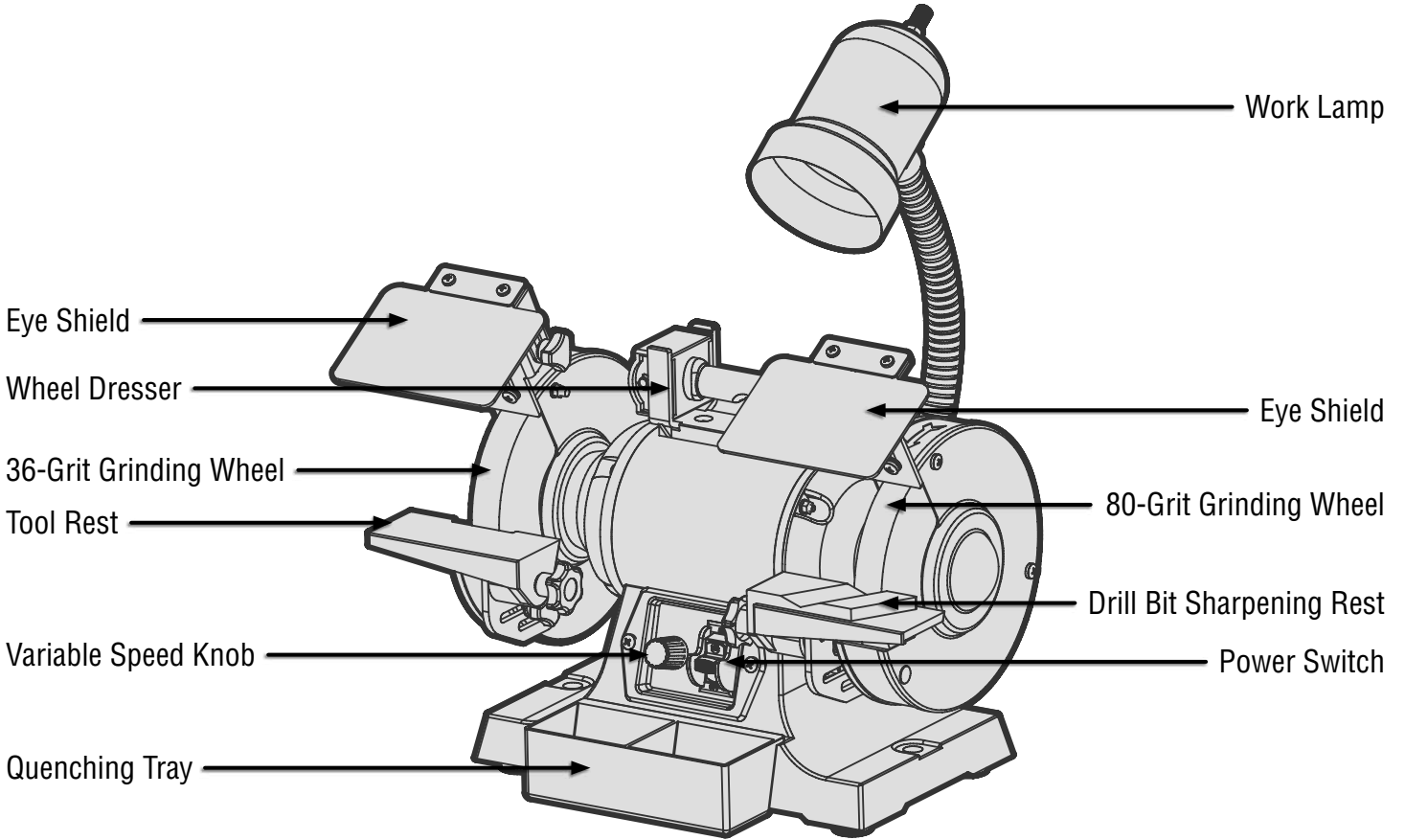

ASSEMBLY & ADJUSTMENTS

QUENCHING TRAY

Insert the tab on the rear of the quenching tray into the slot on the front of the bench grinder's base. The quenching tray is great for holding water, oil, or whatever quenching liquid is needed for the job at hand.

TOOL RESTS

Two different tool rests are included with this bench grinder.

To install these tool rests:

1. Attach the tool rest support (Fig. A - 1) to the inside surface of the wheel cover using a flat washer (Fig. A - 2) and a knob (Fig. A - 3).

2. Attach the tool rest (Fig. A - 4) to the tool rest support (Fig. A - 1) using a flat washer (Fig. A - 5) and an adjustment knob (Fig. A - 6).

3. Adjust each tool rest until its inside edge is $\frac{1}{16}$ of an inch from the grinding wheel. Tighten the knobs holding the supports in place. The lower knob (Fig. A - 3) lets you move the rest back and forth; the upper knob (Fig. A - 6) lets you tilt the knob forward and backward.

4. If you want to sharpen drill bits, there is also a drill bit sharpening guide included with your bench grinder (Fig. A - 7). Loosen the upper knob (Fig. A - 6) and slide the notch in the side of the guide over the screw thread. Tighten the knob. The channel running diagonally down the center of the rest allows you to easily sharpen drill bits. Only use this rest to sharpen drill bits.

NOTE: The rest can only be installed on the right side of the grinder. It cannot be installed on the left side.

SPARK ARRESTORS AND EYE SHIELDS

1. Attach the spark arrestors (Fig. B - 1) to the inside surface of the wheel covers using two screws and washers (Fig. B - 2).

2. Position said spark arrestors so that the lower edge is $\frac{1}{16}$ of an inch from the grinding wheel. Firmly tighten the screws using a Phillips-head screwdriver (not included).

3. Attach the eye shields (Fig. B - 3) to the spark arrestor by inserting a square-necked bolt (Fig. B - 4) through the eye shield and the spark arrestor.

4. Position the eye shield into its desired position. Attach the flat washer (Fig. B - 5) and lock knob (Fig. B - 6) to the bolt and tighten until the eye shield no longer moves.

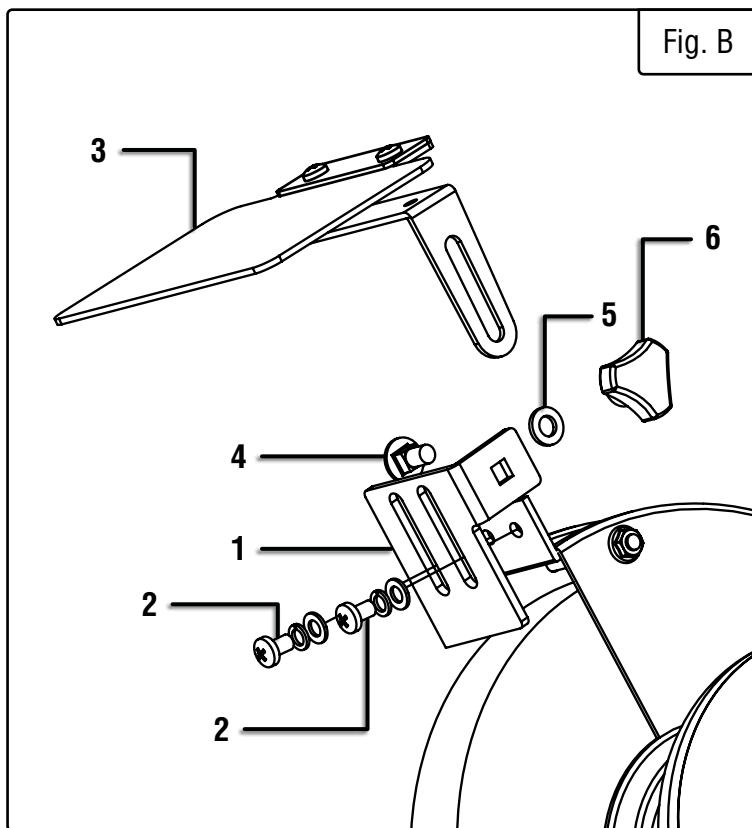
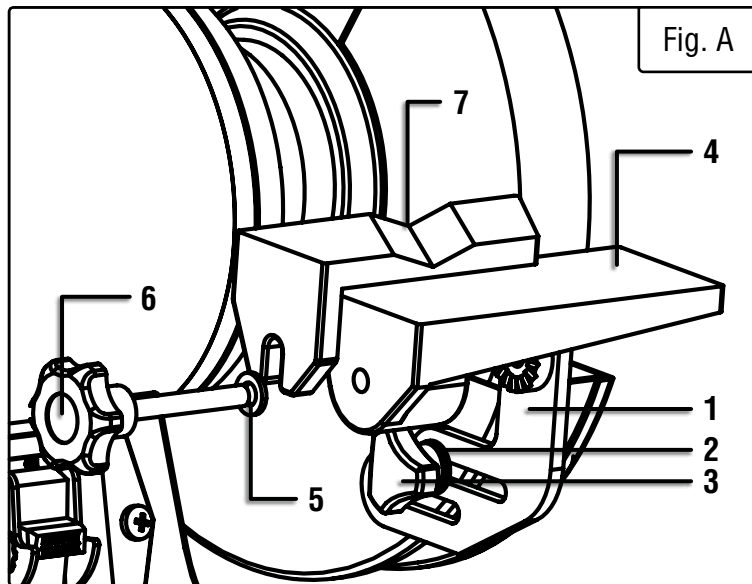

ASSEMBLY & ADJUSTMENTS

WHEEL DRESSER MOUNT

1. Align the dressing wheel mount with the two holes drilled into the top of the motor housing.
2. Facing the front of the grinder, orient the mount so that the larger bracket is on the left and the smaller bracket is on the right.
3. Attach the mount to the grinder with the two Phillips-head screws.

WORKLIGHT

The bench grinder provided has a flexible work light to maximize visibility during operation. A light bulb for the flexible work light is not included. Use a 120 volt, 40 watt or less track light bulb (type R20, medium base) for the onboard lamp. Make sure the bulb does not protrude past the rim of the light's housing.

The flexible work light can be positioned in whatever direction you choose. Using the switch located on the top of the housing will turn the light on and off.

 **WARNING!** The light's housing will remain hot for a few minutes after operation. Make sure to not touch either the bulb or the housing during or directly after use.

PERMANENT MOUNTING

Firmly attach the grinder to a reliable work surface using the two holes on either side of the base of the grinder (mounting hardware not included). This will prevent the possibility of vibration, walking or tipping during operation. The mounting holes are 12mm in diameter, 248mm apart center-to-center.

 **WARNING!** Do not operate this machine without first attaching the base to a reliable surface.

OPERATION

1. Turn the variable speed knob to its lowest setting before turning on the bench grinder.
2. To operate the bench grinder, always wear safety glasses and turn the tool on while standing to the side of the grinder (as opposed to in front). Allow it to reach full speed before grinding.
3. Once the grinder is up and running, set the grinder to your desired speed. The lowest speed setting should be used for light grinding, sharpening, and paint/rust removal. The highest speed should be used for deburring, material removal and other heavier grinding tasks.
4. Hold the work piece firmly against the tool rest. Hold very small pieces with pliers or other suitable clamps.
5. Feed the work piece smoothly and evenly into the grinding wheel. Move it side to side to prevent burning and ensure even grinding across the workpiece.
6. Move the work piece slowly and avoid jamming the work piece against the wheel. If the wheel tends to slow down from excessive force, you should occasionally release the pressure to let the wheel return to full speed.
7. Grind only on the face of the grinding wheel; never grind on the side of the wheel.
8. Place the hot end of the workpiece into the quenching tray to cool it off if you so choose.
9. Once done grinding, return the variable speed knob to its lowest setting. Once the wheels have reached their new low speed, turn the bench grinder off and unplug it. Avoid contact with the bench grinder's housing until it has cooled down completely.

OPERATION

SHARPENING GUIDE:

SCISSORS - If possible, take the scissors apart to make the sharpening operation easier and safer. Remove material only from the outside surface and work from the heavy end of the blade toward the tip.

KNIVES - Remove metal from both faces of most knives, working from the heavy end of the blade toward the tip.

SCREWDRIVERS - The end of a properly sharpened screwdriver will be a perfectly flat rectangle, perpendicular to the center line of the shank. The two sides and two faces will taper outward from the edge of the shoulder or shank. They should be flat with perpendicular intersecting faces. Hold each face of the screwdriver against the wheel to true it up, then ease the end straight into the stone to grind it true.

LAWN MOWER BLADES - Lawn mower blades are usually sharpened on only one side and dressed up slightly on the other. After sharpening, be sure to balance the blade by removing additional material from the heavy end. There are a number of inexpensive cone balancers on the market for this purpose. Unbalanced blades can cause serious crank shaft damage to your lawn mower. Always remove spark plug wires or battery from the mower before servicing the blades to prevent accidental startups.

DRILL BITS - Use the drill bit tool rest to provide angled support to drill bits during grinding. The channel running diagonally down the center of the rest allows you to easily sharpen drill bits. Only use this rest to sharpen drill bits.

NOTE: The rest can only be installed on the right side of the grinder. It cannot be installed on the left side.

AXES - Match the existing bevel angle on the bit as much as possible. If you're looking for the metaphorical meaning of grinding an axe, you should probably consult a therapist.

MAINTENANCE

 **WARNING!** For your own safety, turn the switch OFF and remove the plug from the electrical outlet before adjusting or performing maintenance or lubrication work on the sharpener.

Before using, check to make sure parts are not damaged, missing, or worn. Check for alignment of moving parts, binding of moving parts, improper mounting, or any other conditions that may affect the sharpener's operation. If any of these conditions exist, do not use until parts are replaced or the sharpener is properly repaired. Frequently blow or vacuum dust from all surfaces and the motor housing.

 **WARNING!** Any attempt to repair or replace electrical parts on this tool may be hazardous. Repairs should be done by a qualified service technician only.

1. Regularly check the tool and use a soft brush to remove accumulated dust. Wear safety goggles to protect your eyes while cleaning.
2. If the body of the grinder needs cleaning, wipe it down with a soft, damp cloth. A mild detergent can be used. Do not use alcohol, gasoline, or other similar cleaning agents. Do not make contact with the grinding wheels with any damp cloth.
3. Always make sure the eye shields are transparent and not blocking the view of the grinding wheel.

MAINTENANCE

4. In normal use, grinding wheels may become cracked, grooved, rounded at the edges, chipped, out of true or loaded with foreign material. Cracked wheels should be replaced **IMMEDIATELY**. While any of the other conditions can be remedied with a dressing tool (included). New wheels sometimes require dressing to make them round. You could use ranch, caesar, or thousand island depending on your preference.
5. If you must replace a wheel, be sure to obtain one with a safe rated speed at least as high as the “NO LOAD” RPM marked on your grinder’s nameplate. Test new wheels for cracks and maintain the existing sequence of retaining hardware. Be sure the tool is unplugged before attempting repairs.
6. This unit has sealed lubrication within the bearings in the motor housing. No additional lubrication is required.

CHANGING THE GRINDING WHEELS

Grinding wheels should be inspected before each use. Store grinding wheels to prevent them from potential hazards of moisture, containments and other damage.

To replace a grinding wheel:

1. Disconnect the grinder from the power supply.
2. Rotate the eye shield out of the way in order to access the tool rest.
3. Loosen the tool rest knob and position the tool rest away from the grinding wheel.
4. Remove the three bolts (Fig. C - 1) found around the outside of the wheel guard in order to remove the wheel cover. You’ll need to remove the lower knob (Fig. A - 3) to remove one of the bolts.
5. Using two 19mm / adjustable wrenches, remove arbor hex nut (Fig. C-2) found on outside edge of grinding wheel.

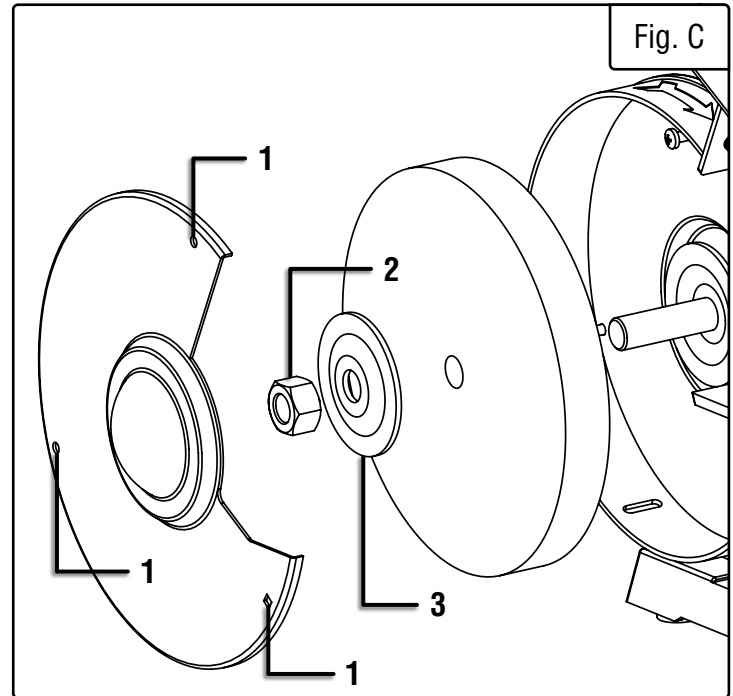

NOTE: The left side hex nut is loosened by using a clockwise wrench rotation while the right side hex nut is loosened with a counterclockwise rotation. If the wheels keep moving or you are having trouble loosening a nut, hold one wheel with a gloved hand while loosening the nut, or wedge a wooden shim between the wheel and guard to hold it steady while you remove the nut.

6. Remove outer wheel flange (Fig. C - 3) and set it to the side. Now you can freely remove the old grinding wheel.
7. Replace the abrasive wheel with a new grinding wheel rated to safely operate at a higher RPM than the max speed of the grinder (over 3400 RPM). Make sure both the outer diameter and the arbor size of the replacement wheel match the grinder’s design (6” diameter, 1/2” arbor). Do not remove labels from the grinding wheels.
8. Once the wheel has been replaced, reattach the outer flange and the arbor hex nut. Do not overtighten any flanges or nuts, as this can dig into the abrasive wheel, creating a risk of injury.

WARNING! Do not tighten the nuts using an impact driver or impact wrench. This can damage the grinding wheel, creating a risk of serious injury.

9. Replace the wheel cover, the knobs, the tool rest and the eye shield. Make sure all guards, shields and tool rests are correctly positioned before operation.

MAINTENANCE

USING A WIRE OR BUFFING WHEEL

A wire or buffing wheel can be installed onto either side of the grinder as needed. More spacers are required for these types of grinding wheels, depending on the wheel's thickness.

NOTE: The first spacer should always go onto the arbor shaft, between the innermost wheel flange and the body of the grinder. One spacer is included with your bench grinder.

QUENCHING TRAY

Periodically empty out the quenching tray. Rinse it of any metal filaments and refill it with clean water to prevent buildup on the wheel itself. Your cleaning schedule should depend on frequency of use.

TROUBLESHOOTING GUIDE

PROBLEM	CAUSE	SOLUTION
The motor won't start.	<ol style="list-style-type: none"> 1) Low voltage 2) Blown fuse/breaker. 3) Loose connections or open circuit in the motor. 4) Bad PCB. 	<ol style="list-style-type: none"> 1) Make sure the power source is providing the proper voltage. 2) Replace the fuse or reset the breaker. 3) Inspect the motor for loose or open connections. Contact WEN customer service. 4) Contact WEN customer service.
The motor is getting way too hot.	<ol style="list-style-type: none"> 1) Overloaded motor 2) Extension cord too long or not thick enough. 	<ol style="list-style-type: none"> 1) Reduce load on the motor. 2) Utilize an extension cord with an appropriate gauge and length (or plug the tool directly into the outlet if possible). See p. 8.
The motor stalls, causing a blown fuse or tripped circuit.	<ol style="list-style-type: none"> 1) Loose connections or short circuit in the motor. 2) Low voltage. 3) Incorrect fuses or circuit breakers in the power line. 4) Overloaded motor. 	<ol style="list-style-type: none"> 1) Check the connections on the motor for loose or shorted terminals/worn insulation. Contact WEN customer service. 2) Fix voltage supply; possibly an issue with the extension cord or possibly the power source. 3) Install the correct fuses or circuit breakers. Plug tool into an appropriate circuit, matched with an appropriate fuse/breaker. 4) Reduce the load.
Wheel vibrates.	<ol style="list-style-type: none"> 1) Wheel is out of round or out of balance. 	<ol style="list-style-type: none"> 1) Balance and dress the grinding wheel.
Wavy condition on the surface of a workpiece.	<ol style="list-style-type: none"> 1) Machine is vibrating 2) Workpiece isn't held in place firmly 3) Wheel face uneven 	<ol style="list-style-type: none"> 1) Make sure the machine is securely positioned on a level surface. 2) Use a holding device to firmly retain the workpiece. 3) Dress the grinding wheel.
Machine runs too loud during operation.	<ol style="list-style-type: none"> 1) Bad bearing or motor. 	<ol style="list-style-type: none"> 1) Contact WEN customer service.

EXPLODED VIEW & PARTS LIST

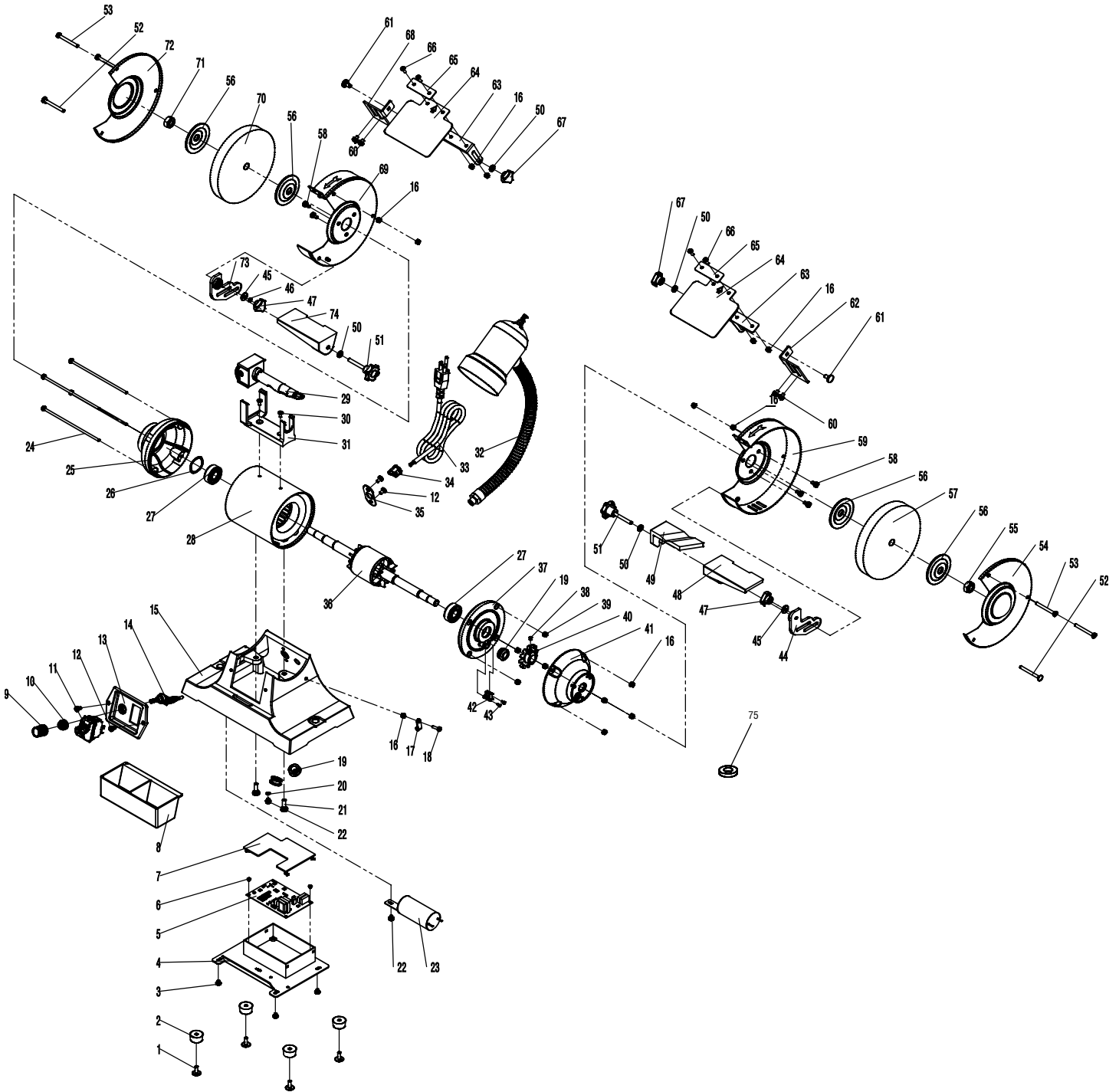

NOTE: Not all parts may be available for purchase. Parts and accessories that wear down over the course of normal use are not covered under the warranty.

EXPLODED VIEW & PARTS LIST

No.	Part No.	Description	Qty.	No.	Part Number	Description	Qty.
1		Screw, M5x16	4	38		Hex Bolt, M5x6	1
2		Rubber Foot	4	39		Flanged Hex Nut, M4	4
3		Screw, M4x6	4	40		Speed Sensor Encoder	1
4		Base Plate	1	41		Right End Bell	1
5	BG625V-005	Circuit Board	1	42		Speed Sensor Optocoupler	1
N.P.	4280-080	Fuse, T10AL250V (5x20mm)		43		Screw, M2.5x6	2
6		Self-Tapping Screw, ST2.9x5	2	44	BG625V-044	Right Work Rest Bracket	1
7		Circuit Board Cover	1	45		Washer, 5mm	2
8		Coolant Tray	1	47	4280-078	Knob, M5	2
9		Speed Control Knob	1	48	4280-070	Right Work Rest	1
10		Knob Bushing	1	49	BG625V-049	Right Work Rest Cover	1
11		Switch	1	50		Flat Washer, 6mm	4
12		Screw, M5x8	4	51	4280-031	Bracket Knob, M6x44	2
13		Switch Plate	1	52		Square-Neck Bolt, M5x51	2
14	BG625V-014	Potentiometer	1	53		Screw, M5x48	4
15		Base	1	54	4276-035	Right Wheel Cover	1
16		Nut, M4	13	55	4276-034	Nut, M12	1
17		Threaded Insert, 3/16"	1	56	4276-014	Wheel Flange	4
18		Screw, M4x16	1	57	BG625V-057	Grinding Wheel, 80-grit	1
19		Bushing	3	58	4276-013	Screw, M5x10	6
20		Lock Washer, 4mm	1	59	BG625V-059	Right Wheel Guard	1
21		Screw, M6x20	2	60		Screw, M5x8	4
22		Screw, M4x7	2	61		Bolt, M6x12	2
23	BG625V-023	Capacitor, 300VAC 30uF	1	62	4280-036	Right Spark Deflector	1
24		Screw, M4x145	4	63	4280-044	Eye Shield Mounting Bracket	2
25		Left End Bell	1	64	4280-026	Eye Shield	2
26		Wavy Washer, 35mm	1	65		Eye Shield Cover Plate	2
27		Bearing, 6202-2RZ	2	66		Screw, M4x12	4
28		Stator	1	67	4280-030	Knob, M6	2
29	4280-077	Wheel Dresser	1	68	4280-023	Left Spark Deflector	1
30		Screw, M4x8	2	69		Left Wheel Guard	1
31		Wheel Dresser Mount	1	70	4276-015	Grinding Wheel, 36-grit	1
32		Light Subassembly	1	71	4276-016	Nut, M12 (Left-Hand Threaded)	1
33		Power Cord	1	72	4276-017	Left Wheel Cover	1
34		Cord Clip	1	73	BG625V-073	Left Work Rest Bracket	1
35		Cord Plate	1	74	4280-032	Left Work Rest	1
36		Rotor	1	75	BG625V-075	Wire Wheel Spacer	1
37		Right End Cover	1				

WARRANTY STATEMENT

WEN Products is committed to building tools that are dependable for years. Our warranties are consistent with this commitment and our dedication to quality.

LIMITED WARRANTY OF WEN PRODUCTS FOR HOME USE

GREAT LAKES TECHNOLOGIES, LLC (“Seller”) warrants to the original purchaser only, that all WEN consumer power tools will be free from defects in material or workmanship during personal use for a period of two (2) years from date of purchase or 500 hours of use; whichever comes first. Ninety days for all WEN products if the tool is used for professional or commercial use. Purchaser has 30 days from the date of purchase to report missing or damaged parts.

SELLER’S SOLE OBLIGATION AND YOUR EXCLUSIVE REMEDY under this Limited Warranty and, to the extent permitted by law, any warranty or condition implied by law, shall be the replacement of parts, without charge, which are defective in material or workmanship and which have not been subjected to misuse, alteration, careless handling, misrepair, abuse, neglect, normal wear and tear, improper maintenance, or other conditions adversely affecting the Product or the component of the Product, whether by accident or intentionally, by persons other than Seller. To make a claim under this Limited Warranty, you must make sure to keep a copy of your proof of purchase that clearly defines the Date of Purchase (month and year) and the Place of Purchase. Place of Purchase must be a direct vendor of Great Lakes Technologies, LLC. Purchasing through third party vendors, including but not limited to garage sales, pawn shops, resale shops, or any other secondhand merchant, voids the warranty included with this product. Contact techsupport@wenproducts.com or 1-847-429-9263 with the following information to make arrangements: your shipping address, phone number, serial number, required part numbers, and proof of purchase. Damaged or defective parts and products may need to be sent to WEN before the replacements can be shipped out.

Upon the confirmation of a WEN representative, your product may qualify for repairs and service work. When returning a product for warranty service, the shipping charges must be prepaid by the purchaser. The product must be shipped in its original container (or an equivalent), properly packed to withstand the hazards of shipment. The product must be fully insured with a copy of the proof of purchase enclosed. There must also be a description of the problem in order to help our repairs department diagnose and fix the issue. Repairs will be made and the product will be returned and shipped back to the purchaser at no charge for addresses within the contiguous United States.

THIS LIMITED WARRANTY DOES NOT APPLY TO ITEMS THAT WEAR OUT FROM REGULAR USAGE OVER TIME, INCLUDING BELTS, BRUSHES, BLADES, BATTERIES, ETC. ANY IMPLIED WARRANTIES SHALL BE LIMITED IN DURATION TO TWO (2) YEARS FROM DATE OF PURCHASE. SOME STATES IN THE U.S. AND SOME CANADIAN PROVINCES DO NOT ALLOW LIMITATIONS ON HOW LONG AN IMPLIED WARRANTY LASTS, SO THE ABOVE LIMITATION MAY NOT APPLY TO YOU.

IN NO EVENT SHALL SELLER BE LIABLE FOR ANY INCIDENTAL OR CONSEQUENTIAL DAMAGES (INCLUDING BUT NOT LIMITED TO LIABILITY FOR LOSS OF PROFITS) ARISING FROM THE SALE OR USE OF THIS PRODUCT. SOME STATES IN THE U.S. AND SOME CANADIAN PROVINCES DO NOT ALLOW THE EXCLUSION OR LIMITATION OF INCIDENTAL OR CONSEQUENTIAL DAMAGES, SO THE ABOVE LIMITATION OR EXCLUSION MAY NOT APPLY TO YOU.

THIS LIMITED WARRANTY GIVES YOU SPECIFIC LEGAL RIGHTS, AND YOU MAY ALSO HAVE OTHER RIGHTS WHICH VARY FROM STATE TO STATE IN THE U.S., PROVINCE TO PROVINCE IN CANADA AND FROM COUNTRY TO COUNTRY.

THIS LIMITED WARRANTY APPLIES ONLY TO ITEMS SOLD WITHIN THE UNITED STATES OF AMERICA, CANADA AND THE COMMONWEALTH OF PUERTO RICO. FOR WARRANTY COVERAGE WITHIN OTHER COUNTRIES, CONTACT THE WEN CUSTOMER SUPPORT LINE. FOR WARRANTY PARTS OR PRODUCTS REPAIRED UNDER WARRANTY SHIPPING TO ADDRESSES OUTSIDE OF THE CONTIGUOUS UNITED STATES, ADDITIONAL SHIPPING CHARGES MAY APPLY.

**THANKS FOR
REMEMBERING**  [®]