

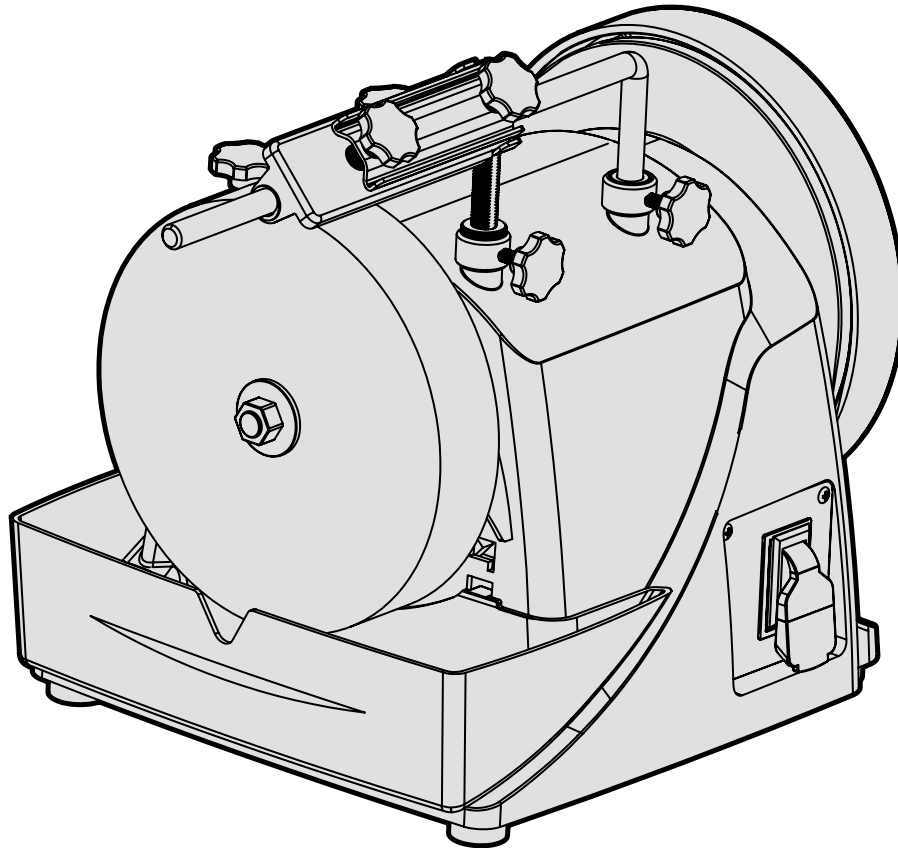

**MODEL BG4108**

# ***8-INCH WATER-COOLED WET / DRY SHARPENER***

**Instruction Manual**



## ***NEED HELP? CONTACT US!***

Have product questions? Need technical support? Please feel free to contact us:



**1-847-429-9263 (M-F 8AM-5PM CST)**



**TECHSUPPORT@WENPRODUCTS.COM**

**IMPORTANT:** Your new tool has been engineered and manufactured to WEN's highest standards for dependability, ease of operation, and operator safety. When properly cared for, this product will supply you years of rugged, trouble-free performance. Pay close attention to the rules for safe operation, warnings, and cautions. If you use your tool properly and for its intended purpose, you will enjoy years of safe, reliable service.

For replacement parts and the most up-to-date instruction manuals, visit ***WENPRODUCTS.COM***

# CONTENTS

<b>WELCOME</b>	<b>3</b>
Introduction .....	3
Specifications.....	3
<b>SAFETY</b>	<b>4</b>
General Safety Rules.....	4
Sharpener Safety Warnings.....	6
Electrical Information.....	8
<b>BEFORE OPERATING</b>	<b>9</b>
Unpacking & Packing List.....	9
Know Your Sharpener .....	10
Assembly & Adjustments.....	11
<b>OPERATION &amp; MAINTENANCE</b>	<b>16</b>
Operation .....	16
Troubleshooting Guide.....	18
Maintenance.....	19
Exploded View & Parts List.....	21
Warranty Statement.....	23

To purchase accessories and replacement parts for your tool, visit ***WENPRODUCTS.COM***

**4-Piece Sharpening Accessory Kit (Model 42704B)**

**3-Piece Sharpening Accessory Kit (Model 42703)**

## INTRODUCTION

Thanks for purchasing the WEN Wet / Dry Sharpener. We know you are excited to put your tool to work, but first, please take a moment to read through the manual. Safe operation of this tool requires that you read and understand this operator's manual and all the labels affixed to the tool. This manual provides information regarding potential safety concerns, as well as helpful assembly and operating instructions for your tool.

 Indicates danger, warning, or caution. The safety symbols and the explanations with them deserve your careful attention and understanding. Always follow the safety precautions to reduce the risk of fire, electric shock or personal injury. However, please note that these instructions and warnings are not substitutes for proper accident prevention measures.

**NOTE:** The following safety information is not meant to cover all possible conditions and situations that may occur. WEN reserves the right to change this product and specifications at any time without prior notice.

At WEN, we are continuously improving our products. If you find that your tool does not exactly match this manual, please visit [wenproducts.com](http://wenproducts.com) for the most up-to-date manual or contact our customer service at **1-847-429-9263**.

**Keep this manual available to all users during the entire life of the tool and review it frequently to maximize safety for both yourself and others.**

## SPECIFICATIONS

Model Number	BG4108
Motor	120V, 60 Hz, 1.0A
Wheel Speed	120 RPM
Wet Wheel Diameter	8-Inches
Wet Wheel Arbor	1/2 Inch (12.7mm)
Wet Wheel Grit	220 Grit
Wet Wheel Part Number	BG4108-034
Leather Honing Wheel Diameter	8.75 Inches
Universal Jig Support Arm Diameter	12mm
Product Weight	17.49 Pounds
Product Dimensions	14.17 in. x 11.81 in. x 11.41 in.

# GENERAL SAFETY RULES

 **WARNING!** Read all safety warnings and all instructions. Failure to follow the warnings and instructions may result in electric shock, fire and/or serious injury.

Safety is a combination of common sense, staying alert and knowing how your item works. The term “power tool” in the warnings refers to your mains-operated (corded) power tool or battery-operated (cordless) power tool.

## SAVE THESE SAFETY INSTRUCTIONS.

### WORK AREA SAFETY

- 1. Keep work area clean and well lit.** Cluttered or dark areas invite accidents.
- 2. Do not operate power tools in explosive atmospheres, such as in the presence of flammable liquids, gases or dust.** Power tools create sparks which may ignite the dust or fumes.
- 3. Keep children and bystanders away while operating a power tool.** Distractions can cause you to lose control.

### ELECTRICAL SAFETY

- 1. Power tool plugs must match the outlet. Never modify the plug in any way. Do not use any adapter plugs with earthed (grounded) power tools.** Unmodified plugs and matching outlets will reduce risk of electric shock.
- 2. Avoid body contact with earthed or grounded surfaces such as pipes, radiators, ranges and refrigerators.** There is an increased risk of electric shock if your body is earthed or grounded.
- 3. Do not expose power tools to rain or wet conditions.** Water entering a power tool will increase the risk of electric shock.
- 4. Do not abuse the cord. Never use the cord for carrying, pulling or unplugging the power tool. Keep cord away from heat, oil, sharp edges or moving parts.** Damaged or entangled cords increase the risk of electric shock.
- 5. When operating a power tool outdoors, use an extension cord suitable for outdoor use.** Use of a cord suitable for outdoor use reduces the risk of electric shock.

- 6. If operating a power tool in a damp location is unavoidable, use a ground fault circuit interrupter (GFCI) protected supply.** Use of a GFCI reduces the risk of electric shock.

### PERSONAL SAFETY

- 1. Stay alert, watch what you are doing and use common sense when operating a power tool. Do not use a power tool while you are tired or under the influence of drugs, alcohol or medication.** A moment of inattention while operating power tools may result in serious personal injury.
- 2. Use personal protective equipment. Always wear eye protection.** Protective equipment such as a respiratory mask, non-skid safety shoes and hearing protection used for appropriate conditions will reduce the risk of personal injury.
- 3. Prevent unintentional starting. Ensure the switch is in the off-position before connecting to power source and/or battery pack, picking up or carrying the tool.** Carrying power tools with your finger on the switch or energizing power tools that have the switch on invites accidents.
- 4. Remove any adjusting key or wrench before turning the power tool on.** A wrench or a key left attached to a rotating part of the power tool may result in personal injury.
- 5. Do not overreach. Keep proper footing and balance at all times.** This enables better control of the power tool in unexpected situations.
- 6. Dress properly. Do not wear loose clothing or jewelry. Keep your hair and clothing away from moving parts.** Loose clothes, jewelry or long hair can be caught in moving parts.

# GENERAL SAFETY RULES

 **WARNING!** Read all safety warnings and all instructions. Failure to follow the warnings and instructions may result in electric shock, fire and/or serious injury.

Safety is a combination of common sense, staying alert and knowing how your item works. The term “power tool” in the warnings refers to your mains-operated (corded) power tool or battery-operated (cordless) power tool.

## SAVE THESE SAFETY INSTRUCTIONS.

**7. If devices are provided for the connection of dust extraction and collection facilities, ensure these are connected and properly used.** Use of dust collection can reduce dust-related hazards.

### POWER TOOL USE AND CARE

**1. Do not force the power tool. Use the correct power tool for your application.** The correct power tool will do the job better and safer at the rate for which it was designed.

**2. Do not use the power tool if the switch does not turn it on and off.** Any power tool that cannot be controlled with the switch is dangerous and must be repaired.

**3. Disconnect the plug from the power source and/or the battery pack from the power tool before making any adjustments, changing accessories, or storing power tools.** Such preventive safety measures reduce the risk of starting the power tool accidentally.

**4. Store idle power tools out of the reach of children and do not allow persons unfamiliar with the power tool or these instructions to operate the power tool.** Power tools are dangerous in the hands of untrained users.

**5. Maintain power tools. Check for misalignment or binding of moving parts, breakage of parts and any other condition that may affect the power tool's operation. If damaged, have the power tool repaired before use.** Many accidents are caused by poorly maintained power tools.

**6. Keep cutting tools sharp and clean.** Properly maintained cutting tools with sharp cutting edges are less likely to bind and are easier to control.

**7. Use the power tool, accessories and tool bits, etc. in accordance with these instructions, taking into account the working conditions and the work to be performed.** Use of the power tool for operations different from those intended could result in a hazardous situation.

**8. Use clamps to secure your workpiece to a stable surface.** Holding a workpiece by hand or using your body to support it may lead to loss of control.

**9. KEEP GUARDS IN PLACE** and in working order.

### SERVICE

**1. Have your power tool serviced by a qualified repair person using only identical replacement parts.** This will ensure that the safety of the power tool is maintained.

### CALIFORNIA PROPOSITION 65 WARNING

Some dust created by power sanding, sawing, grinding, drilling, and other construction activities may contain chemicals, including lead, known to the State of California to cause cancer, birth defects, or other reproductive harm. Wash hands after handling. Some examples of these chemicals are:

- Lead from lead-based paints.
- Crystalline silica from bricks, cement, and other masonry products.
- Arsenic and chromium from chemically treated lumber.

Your risk from these exposures varies depending on how often you do this type of work. To reduce your exposure to these chemicals, work in a well-ventilated area with approved safety equipment such as dust masks specially designed to filter out microscopic particles.

# SHARPENER SAFETY WARNINGS

 **WARNING!** Do not operate the power tool until you have read and understood the following instructions and the warning labels.

## SHARPENER SAFETY

1. This sharpener is designed for sharpening and honing cutting tools, using the appropriate accessories. Using the machine for any other purpose for which it is not designed may result in serious injuries, machine damage and voiding of the warranty.

### Grinding wheel safety:

2. Only use grinding wheels rated for a speed higher than 120 RPM (maximum RPM of the tool).

3. Inspect wheels for cracks or fragments before starting the machine. Replace damaged wheels immediately. Never use a questionable grinding wheel, as the RPM of the machine can send broken wheel fragments flying at high speeds.

4. Do not use a wheel that vibrates. If a wheel vibrates, it may be that the bearings of the shaft need replacing. Make sure the grinding wheel is dressed properly and evenly.

5. Check that the grinding stone can rotate smoothly before starting the machine.

6. The grinding wheel is for grinding. Never attempt to cut anything with the grinding wheel.

7. The use of accessories or attachments not recommended by the manufacturer may result in a risk of personal injury.

8. Make sure the water reservoir is filled with water to the maximum fill line before operation. Check the water level regularly and refill as necessary. Never attempt to sharpen a blade when the grinding stone is dry.

**DANGER: FIRE HAZARD!** Do not grind or polish magnesium or magnesium alloys.

9. Preventing accidental starting. Make sure the power switch is in the OFF position prior to plugging in the machine. Always make sure the power switch is in the OFF position and the machine is unplugged when doing any cleaning, adjustments, assembly, setup operations, or when not in use.

## PERSONAL SAFETY

1. Operate in a well ventilated area. Keep the floor area around the sharpener level and free of slippery substances or other tripping hazards.

2. Wear ANSI-approved safety goggles to protect your eyes from sparks and chips. Use hearing protection to protect yourself from hearing loss.

3. DO NOT wear loose clothing or jewelry as they might get drawn in by the tool. Tie back long hair.

4. People with pacemakers should consult their physician(s) before use. Electromagnetic fields in close proximity to pacemakers could cause pacemaker interference or pacemaker failure.

5. Chips are harmful to your health. Use NIOSH-approved dust masks or other respiratory protection during operation and cleaning.

6. Always turn off and unplug the Sharpener before making any adjustments or repair tasks. Never adjust the Sharpener or the workpiece while the tool is running.

## PREPARING THE SHARPENER

1. When transporting the Sharpener, carry it by either the handle or the base. Never carry the device by its guards or its accessories.

2. Examine the Sharpener for any damaged or missing parts. Replace or repair damaged parts before operation. Periodically check that all nuts, bolts and other fasteners are properly tightened.

3. Do not operate this tool until it is completely assembled and installed according to the instructions. Make sure all adjustments are correct and all connections are tight. Keep all guards in place.

## **SHARPENER SAFETY WARNINGS**

 **WARNING!** Do not operate the power tool until you have read and understood the following instructions and the warning labels.

### **DURING OPERATION**

1. Never start the machine with any load already applied to either grinding wheel. Stand to the side of the sharpener during start-up. Switch it ON and let the sharpener reach full speed for roughly one minute to warm up the wheel and to ensure proper operation.
2. Never grind on a cold wheel. Run the sharpener for one full minute before applying the workpiece. Cold wheels have an increased likelihood of chipping during operation.
3. Only grind on the face of the grinding wheel. Do not grind on the side of the wheel.
4. Keep clear of moving parts. Keep arms, hands and other vital appendages away from the grinding and honing wheel. Do not reach behind or beneath the rotating wheel. Avoid awkward operation and hand positions. An accident could easily send the operator's hand into the wheel.
5. If you are interrupted when operating the sharpener, complete the process and switch the sharpener OFF before looking up.
6. Adjust tool rests and water reservoir as necessary, keeping them close to the grinding wheel. Continue to make adjustments as the wheel wears down.
7. Spacing between the tool rests and the wheel should always be set to 1/8 inch or less. Always hold the workpiece firmly against the tool rest.
8. Never attempt to cut anything with the grinding wheel.
9. Do not use the Sharpener unless all guards are in place. Do not operate with any guard disabled, damaged, or removed. Moving guards must move freely and close instantly.
10. Disconnect the power source and allow the wheels to come to a complete stop before making any adjustments to either the machine or the grinding wheels.
11. Clean the machine thoroughly when changing material types in workpieces. Combining certain materials can increase the chances of an explosion or fire hazard.
12. Should any component of your sharpener be missing / damaged or fail in any way, shut off the switch and remove the plug from power supply outlet. Have a certified technician replace the missing, damaged, or failed parts using only identical replacement parts before resuming operation.

# ELECTRICAL INFORMATION

## GROUNDING INSTRUCTIONS

**In the event of a malfunction or breakdown**, grounding provides the path of least resistance for an electric current and reduces the risk of electric shock. This tool is equipped with an electric cord that has an equipment grounding conductor and a grounding plug. The plug **MUST** be plugged into a matching outlet that is properly installed and grounded in accordance with ALL local codes and ordinances.

**1. Do not modify the plug provided.** If it will not fit the outlet, have the proper outlet installed by a licensed electrician.

**2. Improper connection** of the equipment grounding conductor can result in electric shock. The conductor with the green insulation (with or without yellow stripes) is the equipment grounding conductor. If repair or replacement of the electric cord or plug is necessary, **DO NOT** connect the equipment grounding conductor to a live terminal.

**3. Check** with a licensed electrician or service personnel if you do not completely understand the grounding instructions or whether the tool is properly grounded.

**4. Use only three-wire extension cords** that have three-pronged plugs and outlets that accept the tool's plug. Repair or replace a damaged or worn cord immediately.

**CAUTION!** In all cases, make certain the outlet in question is properly grounded. If you are not sure, have a licensed electrician check the outlet.

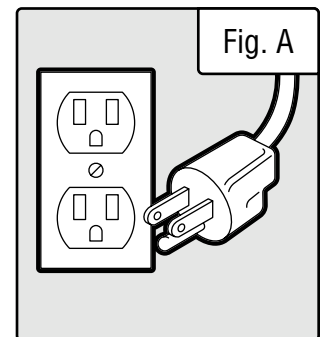

## GUIDELINES AND RECOMMENDATIONS FOR EXTENSION CORDS

When using an extension cord, be sure to use one heavy enough to carry the current your product will draw. An undersized cord will cause a drop in line voltage resulting in loss of power and overheating. The table below shows the correct size to be used according to cord length and ampere rating. When in doubt, use a heavier cord. The smaller the gauge number, the heavier the cord.

AMPERAGE	REQUIRED GAUGE FOR EXTENSION CORDS			
	25 ft.	50 ft.	100 ft.	150 ft.
1.0A	18 gauge	16 gauge	16 gauge	14 gauge

**1. Examine extension cord before use.** Make sure your extension cord is properly wired and in good condition. Always replace a damaged extension cord or have it repaired by a qualified person before using it.

**2. Do not abuse extension cord.** Do not pull on cord to disconnect from receptacle; always disconnect by pulling on plug. Disconnect the extension cord from the receptacle before disconnecting the product from the extension cord. Protect your extension cords from sharp objects, excessive heat and damp/wet areas.

**3. Use a separate electrical circuit for your tool.** This circuit must not be less than a 12-gauge wire and should be protected with a 15A time-delayed fuse. Before connecting the motor to the power line, make sure the switch is in the OFF position and the electric current is rated the same as the current stamped on the motor nameplate. Running at a lower voltage will damage the motor.



# UNPACKING & PACKING LIST

## UNPACKING

With the help of a friend or trustworthy foe, such as one of your in-laws, carefully remove the wet / dry sharpener from the packaging and place it on a sturdy, flat surface. Make sure to take out all contents and accessories. Do not discard the packaging until everything is removed. Check the packing list below to make sure you have all of the parts and accessories. If any part is missing or broken, please contact customer service at **1-847-429-9263** (M-F 8-5 CST), or email [techsupport@wenproducts.com](mailto:techsupport@wenproducts.com).

### Components

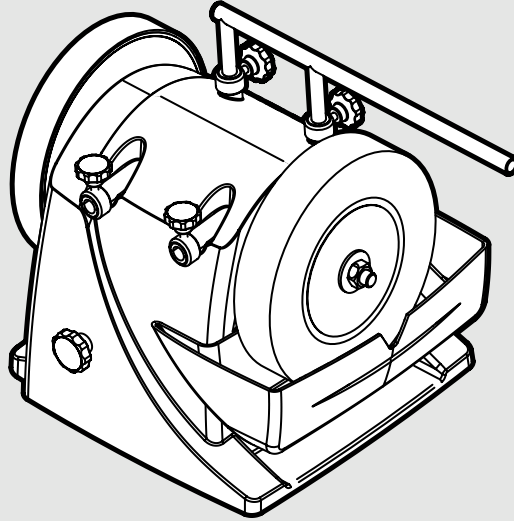

**Sharpener (1)**

### Accessories & Hardware

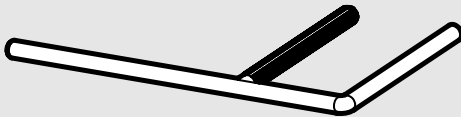

**Workpiece Support (1)**

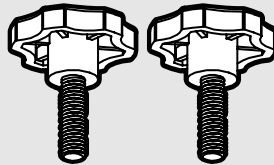

**Mounting Lock Knobs (2)**

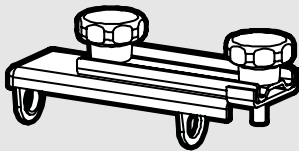

**Chisel Jig (1)**



**Honing Paste (1)**

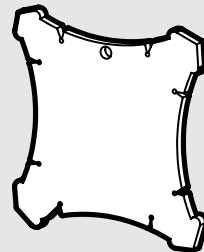

**Angle Guide (1)**

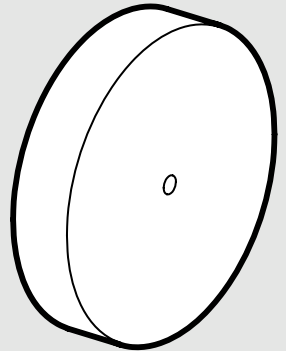

**Grinding Wheel (1)**

# KNOW YOUR SHARPENER

## TOOL PURPOSE

This sharpener features a 8-inch grinding wheel and an 8.75-inch leather stropping wheel for sharpening and polishing dull blades, wood chisels, knives, scissors, carving tools, axes and more. Refer to the following diagrams to become familiarized with all the parts and controls of your sharpener. The components will be referred to later in the manual for assembly and operation instructions.

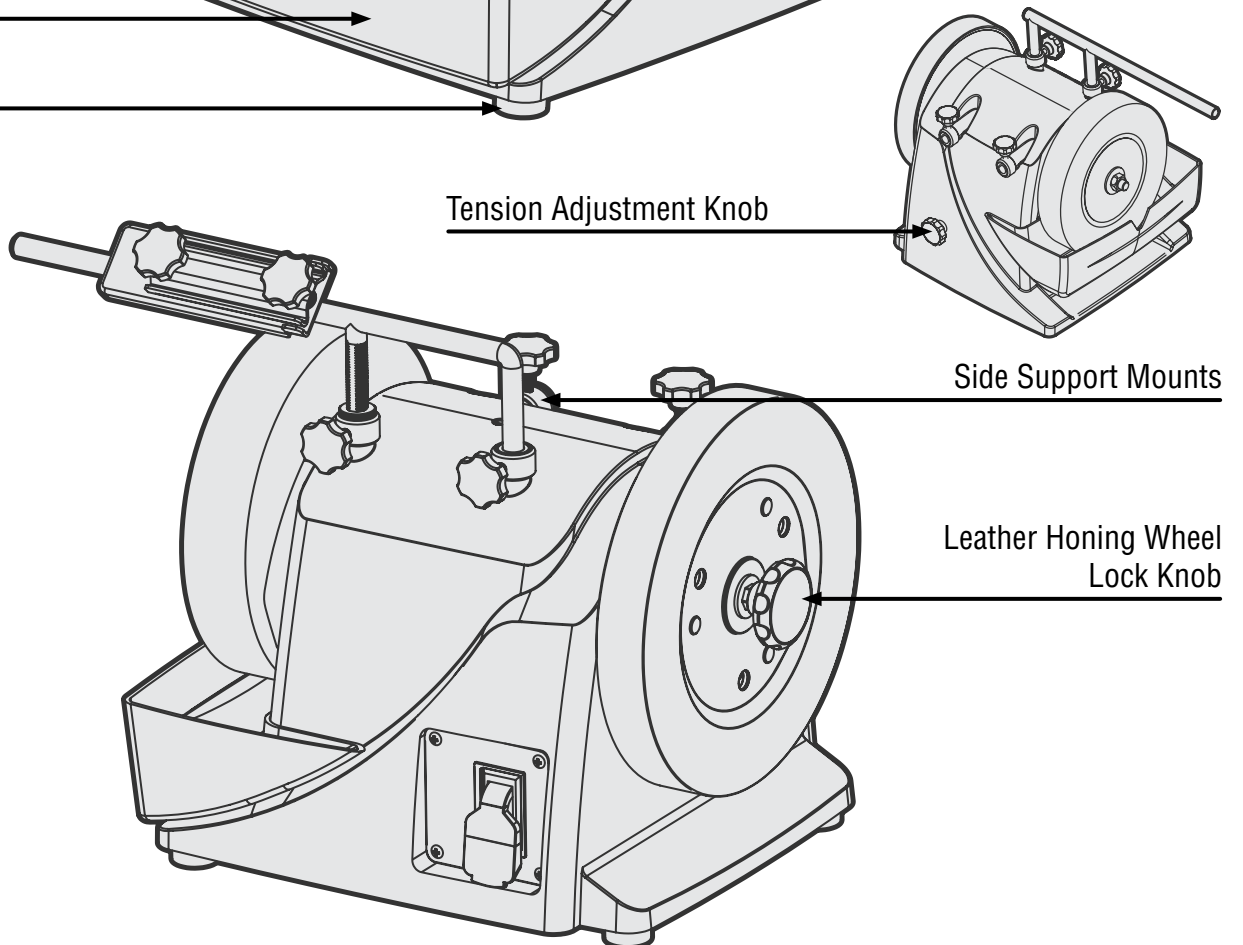
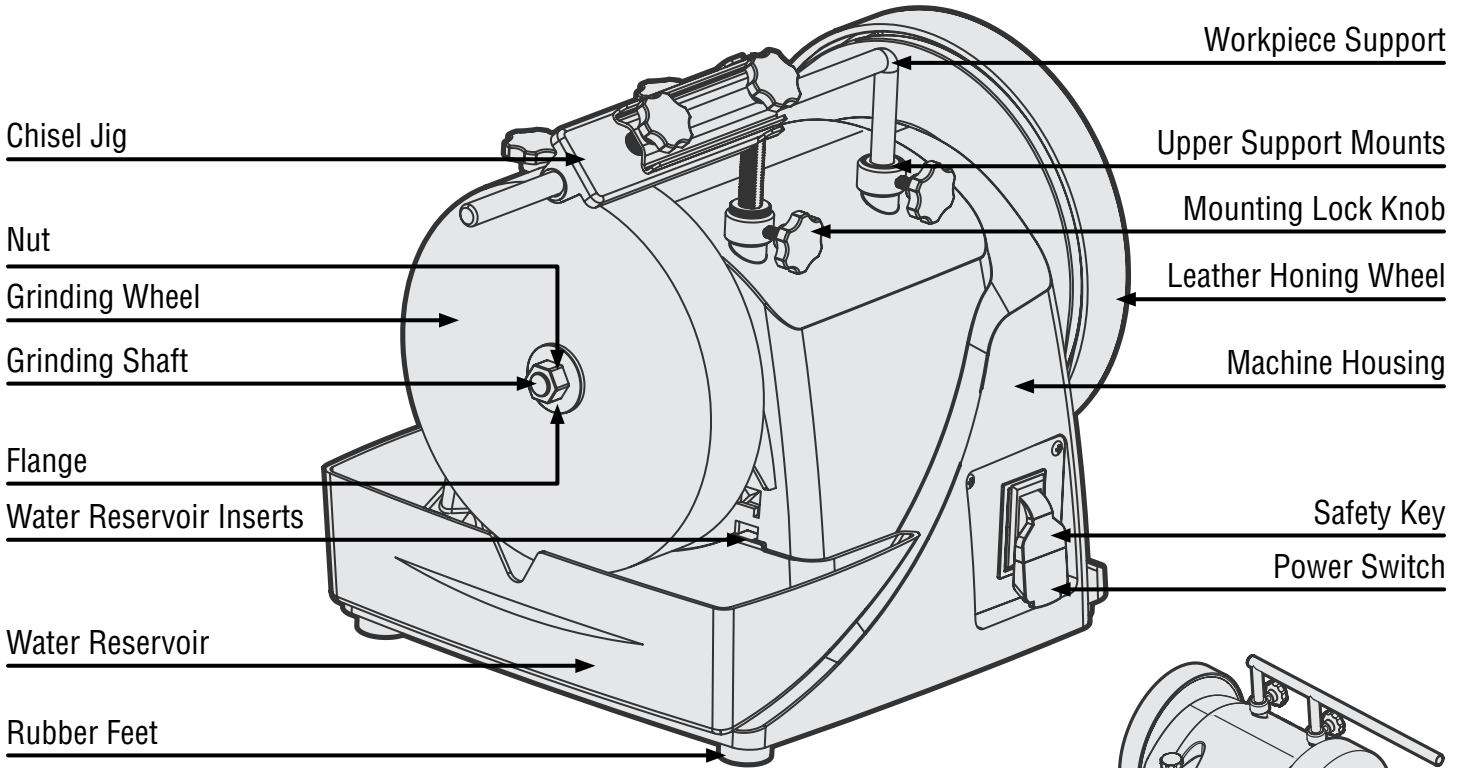

## ASSEMBLY & ADJUSTMENTS

**⚠ WARNING!** To avoid injury from accidental startups, be sure that the tool is switched OFF and unplugged from the power source before inspecting the unit, making adjustments, or changing accessories.

### POSITIONING THE MACHINE

Place the machine on a stable, flat work surface. The machine has four rubber feet pre-installed to increase stability and reduce vibration. Make sure there is sufficient open space around the machine. Route the power cord so that it will not make contact with the sharpener's moving parts.

### INSTALLING THE GRINDING WHEEL

A 220-grit grinding wheel is included with your sharpener, and needs to be installed. Check the grinding wheel regularly to make sure that it is free of damage or cracks.

1. Remove the locking nut (Fig. 1 - 1) using a 19mm wrench or socket (not included). Slide the outer flange (Fig. 1 - 2) off the spindle.
2. Install the grinding wheel (Fig. 1 - 3) onto the spindle (Fig. 1 - 4), flush against the inner flange (Fig. 1 - 5).
3. Slide the outer flange onto the spindle. Install and tighten the locking nut.
4. Rotate the grinding wheel by hand a few turns to check that the wheel is balanced and rotates smoothly.

**NOTE:** The water reservoir must be removed to install or remove the grinding wheel.

### INSTALLING THE WATER RESERVOIR

There are three mounting positions on the grinding wheel side of the machine for installing the water reservoir. For new wheels, use the lower mounting slots (Fig. 2 - 1). As the wheel gets used, you will need to adjust the water reservoir to the upper slots (Fig. 2 - 2).

1. Slide the notches on the water reservoir (Fig. 2 - 3) into the two lower mounting slots.
2. Fill the water reservoir up to the max water level indicated on the side of the water reservoir. See the "FILLING THE WATER RESERVOIR" section for more information.

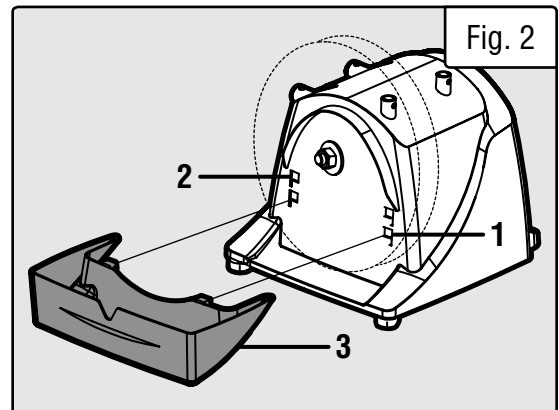
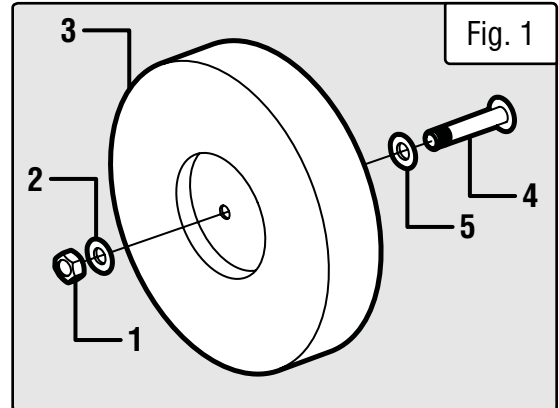

**NOTE:** Once the grinding wheel has been worn down to roughly 6 inches in diameter, move the water reservoir up to the **upper** mounting slots (Fig. 2 - 2). This will allow the wheel to make sufficient contact with the water in the reservoir.

## ASSEMBLY & ADJUSTMENTS

**⚠ WARNING!** To avoid injury from accidental startups, be sure that the tool is switched OFF and unplugged from the power source before inspecting the unit, making adjustments, or changing accessories.

### INSTALLING THE WORK SUPPORT

The universal work support (Fig. 3A / 3B - 1) acts as both a work rest and as an attachment arm for various jigs. The work support can be installed either in the vertical (Fig. 3A) or horizontal (Fig. 3B) position. The diameter of the work support bar is 12 mm.

#### Position A - Against Wheel Rotation

Working against the rotation of the blade removes larger amounts of material quickly. Use this method for shaping blades or sharpening axes. The grinding wheel rotates towards you.

To grind against the direction of the wheel rotation, place the work support in the vertical mounts (Fig. 3A - 2).

#### Position B - Along Wheel Rotation

Working along the rotation of the blade is preferable for more precise jobs that require less material removal. For fine sharpening on tools such as knives, scissors, or other carving instruments, grind with the rotation of the wheel. The grinding wheel rotates away from you.

For grinding and honing along the direction of the wheel rotation, place the work support in the horizontal mounts (Fig. 3B - 2).

#### To mount the work support:

1. Select the suitable position for mounting the work support. Orient the work support so that the support arm is extended over the wheel you'll be working with.
2. Loosen the mounting lock knobs (Fig. 3A / 3B - 3) and slide the work support into the mounting bushings.
3. Adjust the height of the work support to fit your workpiece and operation. Refer to the "SETTING THE ANGLE USING THE ANGLE GUIDE" section for setting up the work support for your blade's bevel using the angle guide.
4. Use the fine adjustment nut (Fig. 3A - 4) on the threaded bar to make fine adjustments to the work support as necessary. Make sure the support arm is completely parallel and level with the face of the wheel, whether it be in the vertical or the horizontal position.
5. Secure the support in place by tightening both locking knobs.

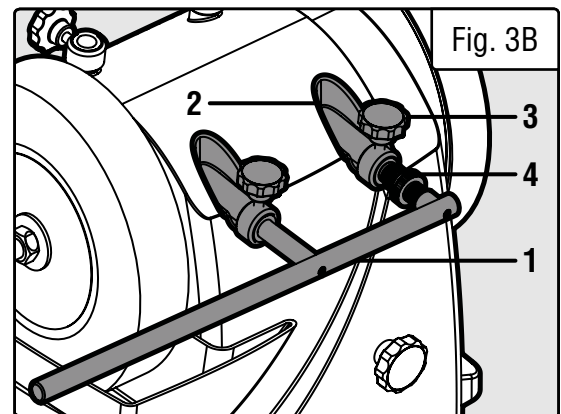
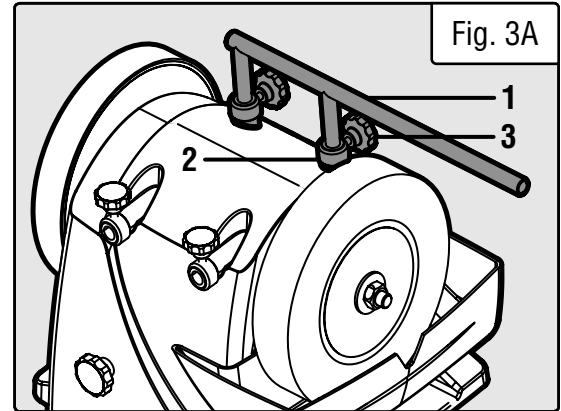

**⚠ CAUTION!** For honing operations, the work support must be installed in the horizontal mounts (Fig. 3B).

## ASSEMBLY & ADJUSTMENTS

**⚠ WARNING!** To avoid injury from accidental startups, be sure that the tool is switched OFF and unplugged from the power source before inspecting the unit, making adjustments, or changing accessories.

### SETTING UP THE HAND PLANE BLADE & CHISEL JIG

The hand plane blade and chisel jig included with your sharpener is designed to assist in sharpening hand plane blades (such as those on a bench plane; they are also called "irons") and chisels.

1. To install the blade or chisel in the jig, loosen the clamping knobs on the jig (Fig. 4 - 1). Insert the body of the blade or chisel into the clamp. Tighten the knobs, ensuring the blade or chisel is securely mounted in the jig.

2. Follow the instructions on the next page for setting the sharpening angle of the blade using the angle guide.

### USING THE WORK SUPPORT ARM AS A WORK REST

If the workpiece is too large to be mounted into the jig, you can rest it directly onto the support arm. This will help you balance the weight of the workpiece and keep it steady.

### OTHER SHARPENING JIGS

To sharpen knives, scissors and axes, you'll need a WEN Sharpening Accessory Kit (**Model 42704B or 42703**) (Fig. 5), sold separately at [wenproducts.com](http://wenproducts.com). Follow the instructions included with your accessory jig kit for assembly and operation.

To sharpen hand planer blades and chisels with extra precision, you'll need a square edge jig (**Model BG9910-076**), sold separately at [wenproducts.com](http://wenproducts.com).

To use the square edge jig, slide it onto the universal work support. Loosen the knobs and install the blade into the jig so that one end of the blade is positioned against the end stop. Tighten the knobs to secure the blade in place.

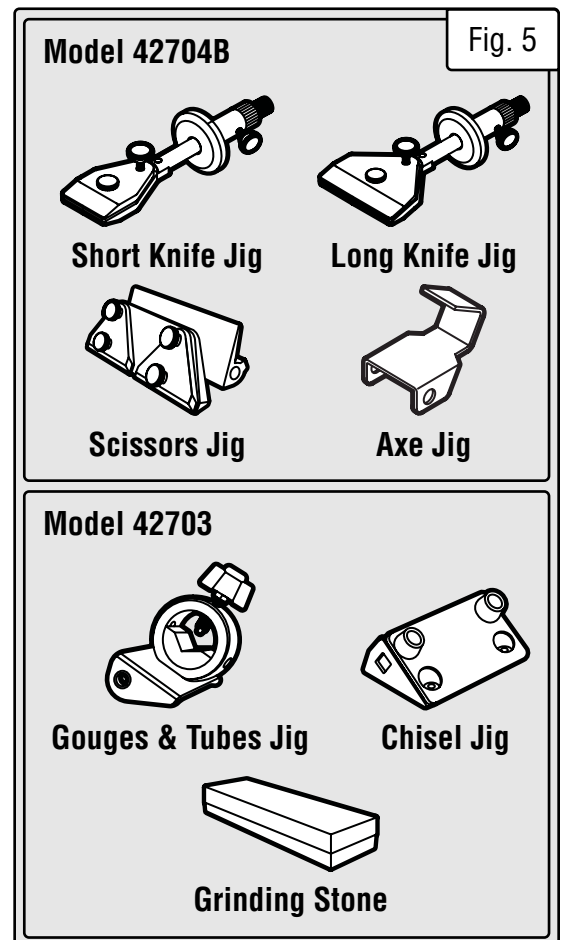
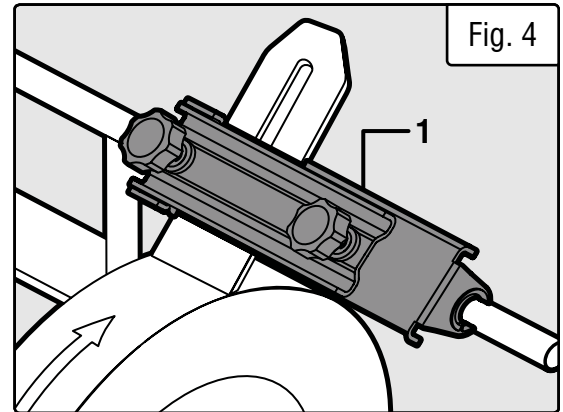

# ASSEMBLY & ADJUSTMENTS

**⚠ WARNING!** To avoid injury from accidental startups, be sure that the tool is switched OFF and unplugged from the power source before inspecting the unit, making adjustments, or changing accessories.

## SETTING THE ANGLE USING THE ANGLE GUIDE

Use the included angle guide (Fig. 6 - 1) to help set the correct angle for sharpening your tools.

**NOTE:** The included angle guide is only accurate for relatively new wheels (8" in diameter). As your wheel wears down, the angle guide will become less accurate.

1. Use the angle guide (Fig. 6 - 1) to measure the bevel angle of your workpiece (Fig. 6 - 2). Place the blade into each angle notch (Fig. 6 - arrows) to find the notch that best fits the bevel of the blade.

2. Mount your workpiece in the appropriate sharpening jig.

3. Place the curved section of the angle guide against the grinding wheel, with the edge of the jig associated with your chosen angle facing up. For example, if your grinding angle is 30 degrees, place the guide as shown in Fig. 7. Adjust the position of the universal support arm and of the jig so that one side of the workpiece edge lays flush against the grinding wheel, and the other side lays flush against the angle guide (Fig. 7).

## FILLING THE WATER RESERVOIR

1. Fill up the container with clean, cold water up to the "max water level" indicated on the side of the reservoir (Fig. 8).

2. Check the water level before each use. Be sure the wheel is sufficiently wet before beginning any grinding operations. New wheels will tend to absorb water during their first use. Make sure that enough water remains in the reservoir throughout the course of sharpening operations.

**TIP:** Putting a magnet inside of the reservoir can collect metal filings as they fall into the water. This helps to prevent build-up of metal filings on the grinding wheel.

**⚠ CAUTION!** Never leave the grinding wheel stored in water, as this will damage one side of the wheel, creating a lack of balance. Empty the water reservoir after each operation.

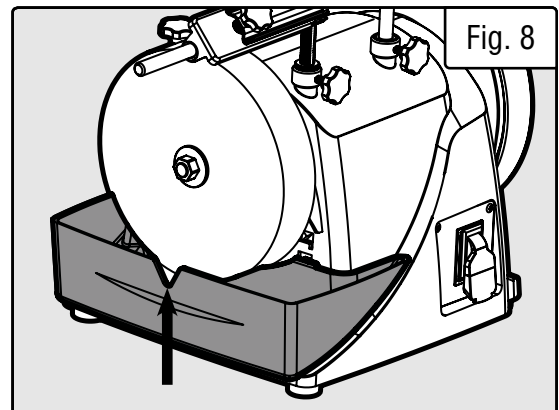
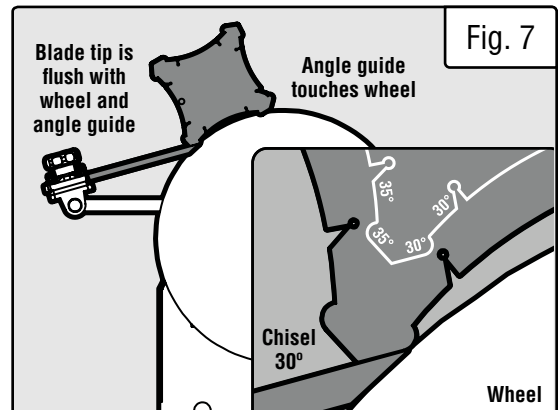
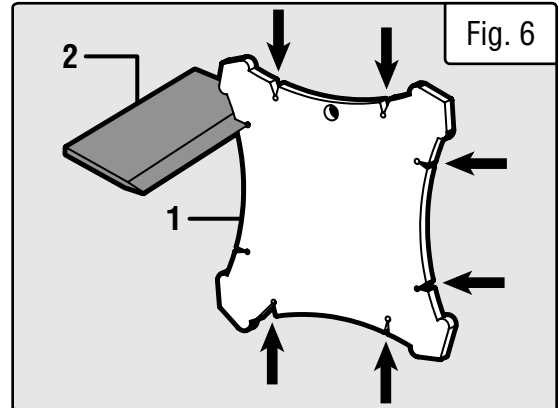

## ASSEMBLY & ADJUSTMENTS

**⚠ WARNING!** To avoid injury from accidental startups, be sure that the tool is switched OFF and unplugged from the power source before inspecting the unit, making adjustments, or changing accessories.

### PREPARING THE STROPPING WHEEL

The leather stropping wheel is pre-installed on the machine. Follow the instructions below to prepare the stropping wheel before honing operations.

1. Turn the wheel by hand and apply a light machine oil evenly to the leather stropping wheel. Use enough to provide a thorough and even coat, but not so much as to dampen the wheel to the point of dripping oil. Turn the wheel in both directions to ensure complete coverage.
2. Using a wooden spreader or other similarly purposed accessory (not included), apply the abrasive honing paste to the stropping wheel, covering the face with a thin, even layer.
3. Make sure the locking knob on the side of the stropping wheel is securely tightened.
4. After the initial layer has been placed, turn the machine ON and continue to evenly distribute the paste with the wooden spreader in light circular motions across the wheel. Once an even distribution has been reached, the stropping wheel is ready to hone.

### ADJUSTING THE FRICTION WHEEL

It may be necessary to adjust the friction wheel if the leather honing wheel or grinding wheel stop during sharpening or honing.

1. Adjust the contact pressure on the friction wheel by turning the tension adjustment knob (Fig. 9 - 1) on the opposite side of the power switch. Turn the tension adjustment knob clockwise to increase tension and counterclockwise to decrease tension. Tighten the tensions adjustment knob only until you feel a slight resistance. Be sure not to over-tighten.

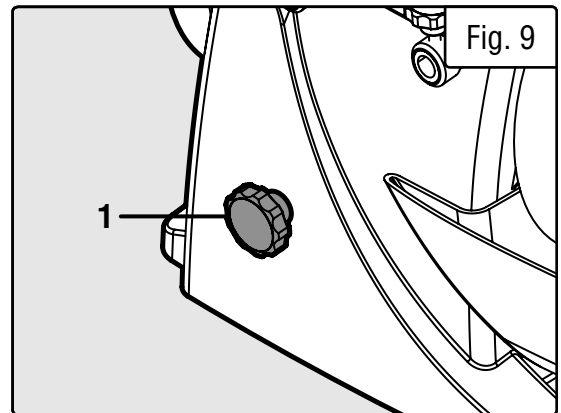

## OPERATION

 **WARNING!** Do not plug in or turn on the tool until it is fully assembled according to the instructions. Read through and become familiarized with the following procedures of handling and adjusting your tool. Failure to follow the safety instructions may result in serious personal injury.

### OPERATION CHECKLIST

Prior to starting your sharpener, check that the following requirements have been met:

- **PERSONAL PROTECTION** - ANSI Z87.1-approved safety glasses, work-appropriate clothing and dust mask are being worn.
- **GRINDING WHEEL** - the grinding wheel has been properly installed, and can be rotated smoothly by hand. The wheel surface is even. Refer to page 19 for dressing the grinding wheel as needed.
- **WORK SUPPORT SET UP** - the work support has been installed in the correct orientation, and has been adjusted using the angle guide to match the bevel angle of the blade.
- **WATER RESERVOIR** - the water reservoir has been installed in the suitable mounting position, and the water has been filled to the maximum fill line.
- **TOOL MOUNTING** - the workpiece is properly mounted in the appropriate jig; for larger workpieces, it can be rested directly onto the work support arm.

### SHARPENING A BLADE

When sharpening knives and scissors, grind with the rotation of the wheel (that is, the grinding wheel rotates away from you). When sharpening axes or chisels, grind against the rotation of the wheel (that is, the grinding wheel rotates toward you).

1. Stand to one side of the sharpener. Plug in and turn ON the machine. Let the grinding wheel run for about one minute to warm up, making sure it is rotating evenly. Ensure there is enough water in the reservoir.
2. Firmly grasp the blade to be sharpened with both hands. Make sure it is properly supported. Feed the blade into the grinding wheel with an even pressure.
3. Slide the blade back and forth along the support arm to ensure even grinding on the blade and even wear on the stone. Grind one side, then the other; repeat. If desired, mark the bevel of the blade with a marker, then take a few passes on the wheel to ensure that material is being removed evenly.

**NOTE:** Do not apply excessive pressure. Guide the blade with light pressure. Let the grinding wheel do the work.

 **CAUTION!** Metal pieces become heated quickly during grinding, so make sure to move the workpiece back and forth to prevent overheating.

 **DANGER! FIRE HAZARD.** Do not grind or polish magnesium or magnesium alloys.



## **OPERATION**

### **HONING A BLADE**

After sharpening the blade, use the leather stropping wheel to remove burrs from the blade and create a smooth, sharp edge.

**TIP:** Scissors should not be honed on the leather stropping wheel. Remove any burrs from the scissors blades by pulling the blades over the surface of a piece of end-grain wood.

1. Turn OFF and disconnect the tool from the power supply.
2. Set up the work support in the horizontal position. Use the angle guide to check the blade angle and adjust the work support as necessary. See the "SETTING THE ANGLE USING THE ANGLE GUIDE" section.
3. Make sure the stropping wheel is properly prepared. See the "PREPARING THE STROPPING WHEEL" section.
4. Switch on the machine and move the blade back and forth evenly along the leather wheel. Do not apply excessive force to the workpiece; allow the honing wheel to do the work.

 **WARNING!** Always hone a blade WITH the direction of the wheel rotation (so the wheel rotates away from you). Never hone against the wheel (so the wheel rotates toward you). The work support must be installed in the horizontal mounts. Attempting to hone the blade against the direction of the wheel rotation, or with the universal support arm in the vertical mounts, will cause severe damage to the honing wheel.

## ***TROUBLESHOOTING GUIDE***

**⚠ WARNING!** Stop using the tool immediately if any of the following problems occur. Repairs and replacements should only be performed by an authorized technician. For any questions, please contact our customer service at **1-847-429-9263**, M-F 8-5 CST or email us at **techsupport@wenproducts.com**.

<b>PROBLEM</b>	<b>POSSIBLE CAUSE</b>	<b>SOLUTION</b>
<b>Motor does not start.</b>	1. Power cord or extension cord damaged or not properly plugged in.	1. Check the power cord, extension cord, power plug, and the power outlet. Make sure the tool is properly plugged in. Do not use the tool if any cord is damaged.
	2. Low voltage.	2. Check that the circuit is providing 120V power.
	3. Defective power switch, defective motor or wiring, defective capacitor, short circuit, or loose connections.	3. Stop using the tool and call <b>1-847-429-9263</b> for customer service.
<b>Motor overheats.</b>	1. Motor overloaded.	1. Reduce load on motor – reduce pressure on workpiece.
	2. Extension cord too long, or of insufficient gauge.	2. Utilize an extension cord of appropriate gauge and length, or plug tool directly into outlet.
<b>Grinding wheel not rotating smoothly or evenly.</b>	1. The wheel is improperly installed.	1. Re-install the wheel.
	2. The wheel is worn out or imbalanced.	2. Replace the wheel.
	3. Spindle is not straight.	3. Stop using the tool and call <b>1-847-429-9263</b> for customer service.
<b>Stropping wheel performance decreases.</b>	1. Improper wheel preparation (lack of oil or honing paste).	1. Prepare the wheel.
	2. Damaged wheel.	2. Replace the wheel.
<b>Wavy finish on the surface of a workpiece.</b>	1. Machine is vibrating.	1. Make sure the machine is securely positioned on a level surface.
	2. Workpiece is not held in place firmly.	2. Make sure you are holding the workpiece or jig firmly.
	3. Wheel face is uneven.	3. Dress the grinding wheel, but please no white after Labor Day.

# MAINTENANCE

**⚠ WARNING!** To avoid injury from accidental startups, be sure that the tool is switched OFF and unplugged from the power source before inspecting the unit, making adjustments, or changing accessories.

**⚠ WARNING!** Any attempt to repair or replace electrical parts on this tool may be hazardous. Servicing of the tool must be performed by a qualified technician. When servicing, use only identical WEN replacement parts. Use of other parts may be hazardous or induce product failure.

## ROUTINE INSPECTION

Before each use, inspect the general condition of the tool. If any of these following conditions exist, do not use until parts are replaced or the Sharpener is properly repaired.

### Check for:

- Loose hardware,
- Misalignment or binding of moving parts,
- Damaged cord/electrical wiring,
- Cracked or broken parts, and
- Any other condition that may affect its safe operation.

## CLEANING & STORAGE

1. Keep the ventilation openings free from dust and debris to prevent the motor from overheating.
2. Use a vacuum or low-pressure compressed air to remove dust and debris from the tool surfaces, motor housing and work area.
3. Wipe the tool surfaces clean with a soft cloth or brush. Make sure water does not get into the tool.

**CAUTION!** Most plastics are susceptible to damage from various types of commercial solvents. Do not use any solvents or cleaning products that could damage the plastic parts. Some of these include but are not limited to: gasoline, carbon tetrachloride, chlorinated cleaning solvents, and household detergents that contain ammonia.

4. Always empty the water reservoir and wait for the grinding wheel to dry completely before storage. Do not store the machine with a wet or damp grinding wheel. Store the tool in a clean and dry place away from the reach of children. Store in temperatures between 41° to 86°F.

5. Cover the tool in order to protect it from dust and moisture. It is preferable to store it in its original packaging with the instruction manual and all accessories.

## WATER RESERVOIR

Periodically empty out the water reservoir. Rinse it of any metal filings and refill it with clean water to prevent buildup on the wheel itself. Your cleaning schedule should depend on frequency of use.

Adjust the water reservoir mounting height to make sure water levels are always sufficient to keep the wheel wet during grinding operations.

## DRESSING THE GRINDING WHEEL

Dress the grinding wheel periodically using dressing tools (sold separately) to restore or adjust the wheel's abrasiveness. Follow the instructions that are included with your dressing tools and accessories to properly dress the grinding wheel.

### Using a dressing stone with a coarse/smooth face:

- To remove larger amount of materials quickly, dress the wheel for coarse grinding. Apply the coarse face of the dressing stone to the grinding wheel to roughen the wheel's surface.
- For fine grinding, apply the smooth face of the dressing stone to the grinding wheel to create a finer surface.

**Maintenance continues on the next page.**

## MAINTENANCE

### REPLACING THE GRINDING WHEEL

Grinding wheels should be inspected for any damage or cracking before each use. Store the grinding wheels to prevent them from the potential hazards of moisture, containments and other damage. Replacement 8-inch grinding wheels (**Part BG4108-034**) can be purchased from [wenproducts.com](http://wenproducts.com).

#### To replace a grinding wheel:

1. Turn OFF and disconnect the sharpener from the power supply. Hold the grinding wheel to prevent it from rotating. Remove the lock nut (Fig. 10 - 1).

2. Remove the outer flange (Fig. 10 - 2) and the wheel (Fig. 10 - 3). See the "INSTALLING THE GRINDING WHEEL" section to install the new grinding wheel.

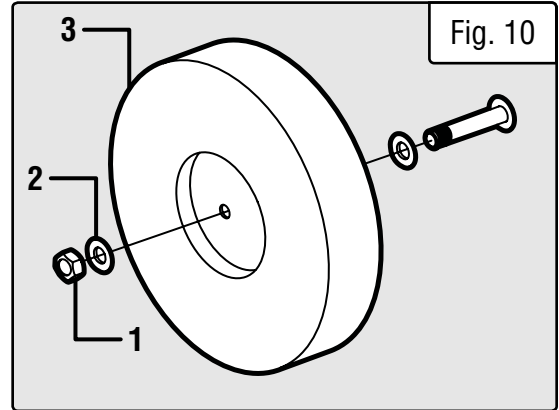

### REPLACING THE STROPPING WHEEL

Inspect the leather stropping wheel for any damage or wear before each use. If the leather stropping wheel becomes damaged or worn, replace it as follows. Replacement 8.75-inch leather stropping wheels (**Part BG4108-002**) can be purchased from [wenproducts.com](http://wenproducts.com).

1. Unscrew the locking knob (Fig. 11 - 1).

2. Remove the outer flange (Fig. 11 - 2) and stropping wheel (Fig. 11 - 3) from the spindle. Install a new stropping wheel. Re-install the outer flange and locking knob. Tighten the locking knob by hand.

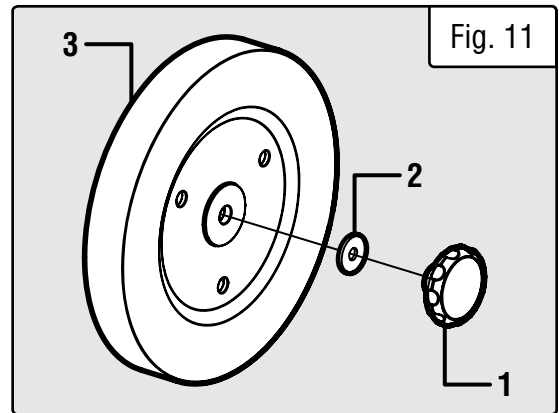

### PRODUCT DISPOSAL

Used power tools should not be disposed of together with household waste. This product contains electronic components that should be recycled. Please take this product to your local recycling facility for responsible disposal and to minimize its environmental impact.

# EXPLODED VIEW & PARTS LIST

**NOTE:** Not all parts may be available for purchase. Parts and accessories that wear down over the course of normal use are not covered under the warranty.

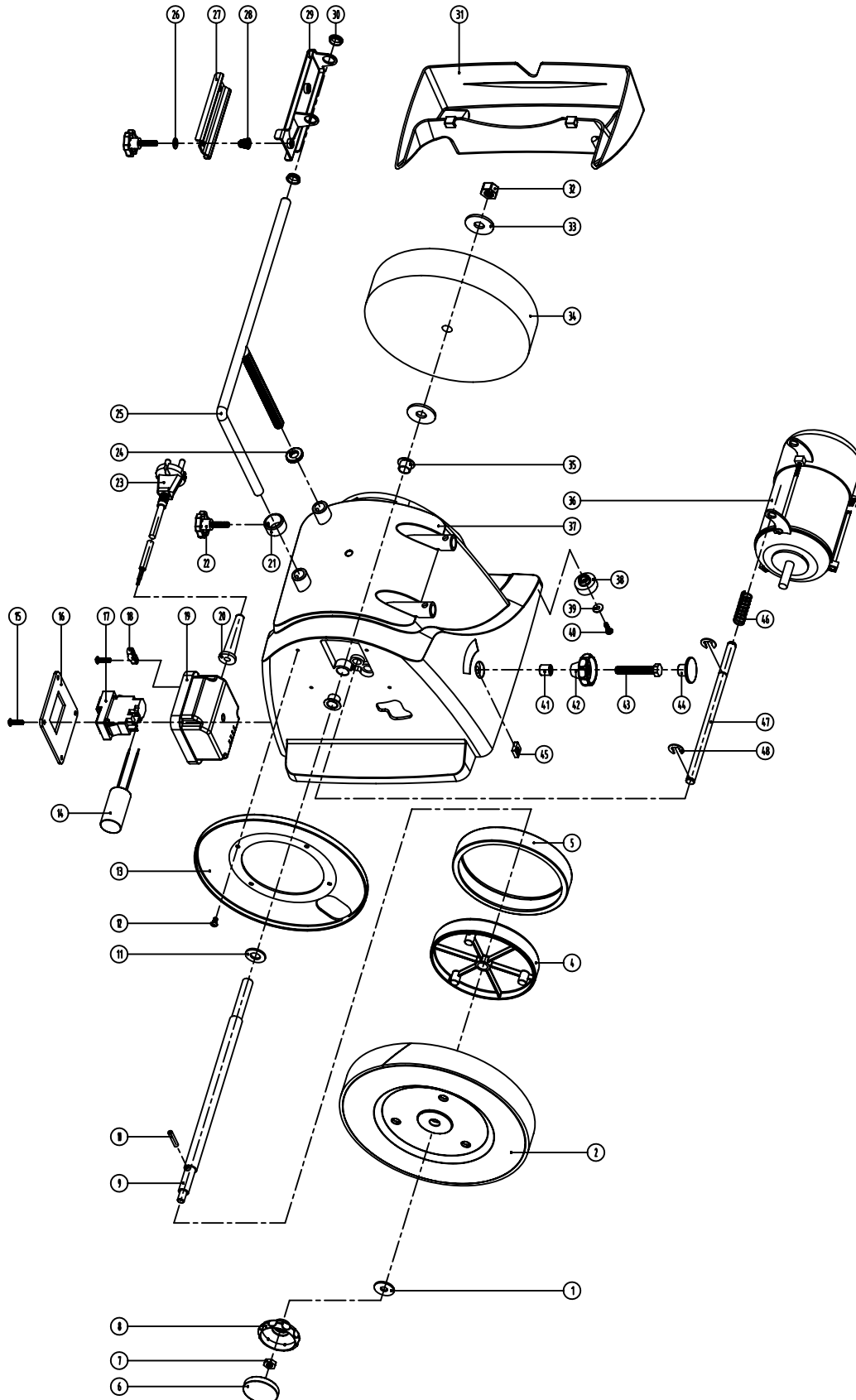

## EXPLODED VIEW & PARTS LIST

NO.	PART NO.	DESCRIPTION	QTY.	NO.	PART NO.	DESCRIPTION	QTY.
1	BG4108-001	Washer $\phi$ 8.4x24x2	1	25	BG4108-025	Tool Support	1
2	BG4108-002	Leather Sharpening Wheel Assembly	1	26	BG4108-026	Washer $\phi$ 6.2x12x1.5 (Jig 70)	2
4	BG4108-004	Friction Wheel Plastic Part	1	27	BG4108-027	Moving Clamp (Jig 70)	1
5	BG4108-005	Friction Wheel Rubber Part	1	28	BG4108-028	Spring (Jig 70)	2
6	BG4108-006	Star Handle Cap	1	29	BG4108-029	Fixed Clamp (Jig 70)	1
7	BG4108-007	Nut M8	2	30	BG4108-030	Plastic Bush (Jig 70)	2
8	BG4108-008	Star Handle	1	31	BG4108-031	Water Tank	1
9	BG4108-009	Grinding Stone Axle	1	32	BG4108-032	Nut M12 Left-Hand Thread	1
10	BG4108-010	Dowel Pin $\phi$ 5x25	1	33	BG4108-033	Disc $\phi$ 12.4x34x2.8	2
11	BG4108-011	Washer $\phi$ 10.4x24x2	1	34	BG4108-034	Wetgrind $\phi$ 200x40x12mm K 220	1
12	BG4108-012	Oval Head Sheet Metal Screw ST3.9x8	4	35	BG4108-035	Flange Sleeve	2
13	BG4108-013	Protective Cover	1	36	BG4108-036	Motor Assembly	1
14	BG4108-014	Capacitor 6uF	1	37	BG4108-037	Machine Casing	1
15	BG4108-015	Oval Head Sheet Metal Screw ST3.9x16	4	38	BG4108-038	Rubber Foot Part	4
16	BG4108-016	Switch Panel Part	1	39	BG4108-039	Washer $\phi$ 4.2x12x1	4
17	BG4108-017	Power Switch	1	40	BG4108-040	Oval Head Sheet Metal Screw ST3.9x12	4
18	BG4108-018	Power Cord Clamp with 2 Self-Taper Screw	1	41	BG4108-041	Rubber Cap	1
19	BG4108-019	Switch Box	1	42	BG4108-042	Star Grip Knob Part	1
20	BG4108-020	Cord Protective Sleeve	1	43	BG4108-043	Star Grip Bolt Part	1
21	BG4108-021	Fixing Collar	4	44	BG4108-044	Star Grip Knob Cap Part	1
22	BG4108-022	Knob M6x25	6	45	BG4108-045	Flat Hexagon Nut M8	1
23	BG4108-023	Power Cord	1	46	BG4108-046	Spring on Motor Hanging Shaft	1
24	BG4108-024	Knurled Nut M12	1	47	BG4108-047	Motor Hanging Shaft	1
				48	BG4108-048	Lock Washer	3

**NOTE:** Not all parts may be available for purchase. Parts and accessories that wear down over the course of normal use are not covered under the warranty.

# **WARRANTY STATEMENT**

WEN Products is committed to building tools that are dependable for years. Our warranties are consistent with this commitment and our dedication to quality.

## **LIMITED WARRANTY OF WEN PRODUCTS FOR HOME USE**

GREAT LAKES TECHNOLOGIES, LLC (“Seller”) warrants to the original purchaser only, that all WEN consumer power tools will be free from defects in material or workmanship during personal use for a period of two (2) years from date of purchase or 500 hours of use; whichever comes first. Ninety days for all WEN products if the tool is used for professional or commercial use. Purchaser has 30 days from the date of purchase to report missing or damaged parts.

SELLER’S SOLE OBLIGATION AND YOUR EXCLUSIVE REMEDY under this Limited Warranty and, to the extent permitted by law, any warranty or condition implied by law, shall be the replacement of parts, without charge, which are defective in material or workmanship and which have not been subjected to misuse, alteration, careless handling, misrepair, abuse, neglect, normal wear and tear, improper maintenance, or other conditions adversely affecting the Product or the component of the Product, whether by accident or intentionally, by persons other than Seller. To make a claim under this Limited Warranty, you must make sure to keep a copy of your proof of purchase that clearly defines the Date of Purchase (month and year) and the Place of Purchase. Place of Purchase must be a direct vendor of Great Lakes Technologies, LLC. Purchasing through third party vendors, including but not limited to garage sales, pawn shops, resale shops, or any other secondhand merchant, voids the warranty included with this product. Contact [tech-support@wenproducts.com](mailto:tech-support@wenproducts.com) or 1-847-429-9263 with the following information to make arrangements: your shipping address, phone number, serial number, required part numbers, and proof of purchase. Damaged or defective parts and products may need to be sent to WEN before the replacements can be shipped out.

Upon the confirmation of a WEN representative, your product may qualify for repairs and service work. When returning a product for warranty service, the shipping charges must be prepaid by the purchaser. The product must be shipped in its original container (or an equivalent), properly packed to withstand the hazards of shipment. The product must be fully insured with a copy of the proof of purchase enclosed. There must also be a description of the problem in order to help our repairs department diagnose and fix the issue. Repairs will be made and the product will be returned and shipped back to the purchaser at no charge for addresses within the contiguous United States.

THIS LIMITED WARRANTY DOES NOT APPLY TO ITEMS THAT WEAR OUT FROM REGULAR USAGE OVER TIME, INCLUDING BELTS, BRUSHES, BLADES, BATTERIES, ETC. ANY IMPLIED WARRANTIES SHALL BE LIMITED IN DURATION TO TWO (2) YEARS FROM DATE OF PURCHASE. SOME STATES IN THE U.S. AND SOME CANADIAN PROVINCES DO NOT ALLOW LIMITATIONS ON HOW LONG AN IMPLIED WARRANTY LASTS, SO THE ABOVE LIMITATION MAY NOT APPLY TO YOU.

IN NO EVENT SHALL SELLER BE LIABLE FOR ANY INCIDENTAL OR CONSEQUENTIAL DAMAGES (INCLUDING BUT NOT LIMITED TO LIABILITY FOR LOSS OF PROFITS) ARISING FROM THE SALE OR USE OF THIS PRODUCT. SOME STATES IN THE U.S. AND SOME CANADIAN PROVINCES DO NOT ALLOW THE EXCLUSION OR LIMITATION OF INCIDENTAL OR CONSEQUENTIAL DAMAGES, SO THE ABOVE LIMITATION OR EXCLUSION MAY NOT APPLY TO YOU.

THIS LIMITED WARRANTY GIVES YOU SPECIFIC LEGAL RIGHTS, AND YOU MAY ALSO HAVE OTHER RIGHTS WHICH VARY FROM STATE TO STATE IN THE U.S., PROVINCE TO PROVINCE IN CANADA AND FROM COUNTRY TO COUNTRY.

THIS LIMITED WARRANTY APPLIES ONLY TO ITEMS SOLD WITHIN THE UNITED STATES OF AMERICA, CANADA AND THE COMMONWEALTH OF PUERTO RICO. FOR WARRANTY COVERAGE WITHIN OTHER COUNTRIES, CONTACT THE WEN CUSTOMER SUPPORT LINE. FOR WARRANTY PARTS OR PRODUCTS REPAIRED UNDER WARRANTY SHIPPING TO ADDRESSES OUTSIDE OF THE CONTIGUOUS UNITED STATES, ADDITIONAL SHIPPING CHARGES MAY APPLY.

**THANKS FOR  
REMEMBERING**

