

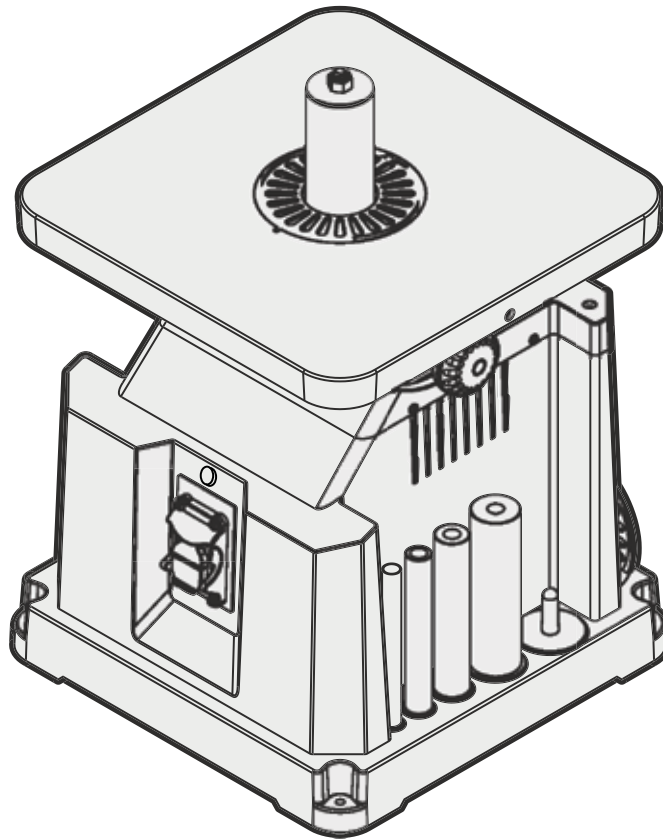

**MODEL AT6535**

# ***OSCILLATING SPINDLE SANDER***

**Instruction Manual**



 **CSA**<sup>®</sup>  
C US  
226766

## ***NEED HELP? CONTACT US!***

Have product questions? Need technical support? Please feel free to contact us:



**1-800-232-1195 (M-F 8AM-5PM CST)**



**TECHSUPPORT@WENPRODUCTS.COM**

**IMPORTANT:** Your new tool has been engineered and manufactured to WEN's highest standards for dependability, ease of operation, and operator safety. When properly cared for, this product will supply you years of rugged, trouble-free performance. Pay close attention to the rules for safe operation, warnings, and cautions. If you use your tool properly and for its intended purpose, you will enjoy years of safe, reliable service.

For replacement parts and the most up-to-date instruction manuals, visit ***WENPRODUCTS.COM***

# CONTENTS

<b>WELCOME</b>	<b>3</b>
Introduction .....	3
Specifications.....	3
<b>SAFETY</b>	<b>4</b>
General Safety Rules .....	4
Spindle Sander Safety Warnings.....	6
Electrical Information .....	8
<b>BEFORE OPERATING</b>	<b>9</b>
Know Your Spindle Sander .....	9
Assembly & Adjustments.....	11
<b>OPERATION &amp; MAINTENANCE</b>	<b>14</b>
Operation .....	14
Maintenance.....	15
Troubleshooting Guide.....	16
Exploded View & Parts List.....	17
Warranty Statement .....	20

To purchase accessories and replacement parts for your tool, visit **WENPRODUCTS.COM**

Sanding sleeves of various grits can be purchased from **wenproducts.com**  
by searching your product's model number **AT6535**.

## INTRODUCTION

Thanks for purchasing the WEN Spindle Sander. We know you are excited to put your tool to work, but first, please take a moment to read through the manual. Safe operation of this tool requires that you read and understand this operator's manual and all the labels affixed to the tool. This manual provides information regarding potential safety concerns, as well as helpful assembly and operating instructions for your tool.

 Indicates danger, warning, or caution. The safety symbols and the explanations with them deserve your careful attention and understanding. Always follow the safety precautions to reduce the risk of fire, electric shock or personal injury. However, please note that these instructions and warnings are not substitutes for proper accident prevention measures.

**NOTE:** The following safety information is not meant to cover all possible conditions and situations that may occur. WEN reserves the right to change this product and specifications at any time without prior notice.

At WEN, we are continuously improving our products. If you find that your tool does not exactly match this manual, please visit [wenproducts.com](http://wenproducts.com) for the most up-to-date manual or contact our customer service at **1-800-232-1195**.

**Keep this manual available to all users during the entire life of the tool and review it frequently to maximize safety for both yourself and others.**

## SPECIFICATIONS

Model Number	AT6535
Power	120V AC, 60 Hz, 3.5A
Motor Speed (No-Load)	2000 RPM
Spindle Oscillation (No-Load)	58 OPM
Spindle Diameter	1/2 Inch
Rubber Drum Diameter (4)	3/4", 1", 1-1/2", 2"
	19mm, 26mm, 38mm, 51mm
Sanding Sleeve Diameter (5)	1/2", 3/4", 1", 1-1/2", 2" (80-Grit)
	13mm, 19mm, 26mm, 38mm, 51mm
Dust Port Size	2" O.D., 1-7/8" I.D.
Work Table Bevel Angle	0° to 45°
Table Dimensions	14-1/2 in. x 14-1/2 in.
IP Rating	IP20
Product Net Weight	33.2 Pounds
Assembled Dimensions	14-3/4 in. x 14-3/4 in. x 16-3/4 in.

# GENERAL SAFETY RULES

 **WARNING!** Read all safety warnings and all instructions. Failure to follow the warnings and instructions may result in electric shock, fire and/or serious injury.

Safety is a combination of common sense, staying alert and knowing how your item works. The term “power tool” in the warnings refers to your mains-operated (corded) power tool or battery-operated (cordless) power tool.

## SAVE THESE SAFETY INSTRUCTIONS.

### WORK AREA SAFETY

- 1. Keep work area clean and well lit.** Cluttered or dark areas invite accidents.
- 2. Do not operate power tools in explosive atmospheres, such as in the presence of flammable liquids, gases or dust.** Power tools create sparks which may ignite the dust or fumes.
- 3. Keep children and bystanders away while operating a power tool.** Distractions can cause you to lose control.

### ELECTRICAL SAFETY

- 1. Power tool plugs must match the outlet. Never modify the plug in any way. Do not use any adapter plugs with earthed (grounded) power tools.** Unmodified plugs and matching outlets will reduce risk of electric shock.
- 2. Avoid body contact with earthed or grounded surfaces such as pipes, radiators, ranges and refrigerators.** There is an increased risk of electric shock if your body is earthed or grounded.
- 3. Do not expose power tools to rain or wet conditions.** Water entering a power tool will increase the risk of electric shock.
- 4. Do not abuse the cord. Never use the cord for carrying, pulling or unplugging the power tool. Keep cord away from heat, oil, sharp edges or moving parts.** Damaged or entangled cords increase the risk of electric shock.
- 5. When operating a power tool outdoors, use an extension cord suitable for outdoor use.** Use of a cord suitable for outdoor use reduces the risk of electric shock.

**6. If operating a power tool in a damp location is unavoidable, use a ground fault circuit interrupter (GFCI) protected supply.** Use of a GFCI reduces the risk of electric shock.

### PERSONAL SAFETY

- 1. Stay alert, watch what you are doing and use common sense when operating a power tool. Do not use a power tool while you are tired or under the influence of drugs, alcohol or medication.** A moment of inattention while operating power tools may result in serious personal injury.
- 2. Use personal protective equipment. Always wear eye protection.** Protective equipment such as a respiratory mask, non-skid safety shoes and hearing protection used for appropriate conditions will reduce the risk of personal injury.
- 3. Prevent unintentional starting. Ensure the switch is in the off-position before connecting to power source and/or battery pack, picking up or carrying the tool.** Carrying power tools with your finger on the switch or energizing power tools that have the switch on invites accidents.
- 4. Remove any adjusting key or wrench before turning the power tool on.** A wrench or a key left attached to a rotating part of the power tool may result in personal injury.
- 5. Do not overreach. Keep proper footing and balance at all times.** This enables better control of the power tool in unexpected situations.
- 6. Dress properly. Do not wear loose clothing or jewelry. Keep your hair and clothing away from moving parts.** Loose clothes, jewelry or long hair can be caught in moving parts.

# GENERAL SAFETY RULES

 **WARNING!** Read all safety warnings and all instructions. Failure to follow the warnings and instructions may result in electric shock, fire and/or serious injury.

Safety is a combination of common sense, staying alert and knowing how your item works. The term “power tool” in the warnings refers to your mains-operated (corded) power tool or battery-operated (cordless) power tool.

## SAVE THESE SAFETY INSTRUCTIONS.

**7. If devices are provided for the connection of dust extraction and collection facilities, ensure these are connected and properly used.** Use of dust collection can reduce dust-related hazards.

### POWER TOOL USE AND CARE

**1. Do not force the power tool. Use the correct power tool for your application.** The correct power tool will do the job better and safer at the rate for which it was designed.

**2. Do not use the power tool if the switch does not turn it on and off.** Any power tool that cannot be controlled with the switch is dangerous and must be repaired.

**3. Disconnect the plug from the power source and/or the battery pack from the power tool before making any adjustments, changing accessories, or storing power tools.** Such preventive safety measures reduce the risk of starting the power tool accidentally.

**4. Store idle power tools out of the reach of children and do not allow persons unfamiliar with the power tool or these instructions to operate the power tool.** Power tools are dangerous in the hands of untrained users.

**5. Maintain power tools. Check for misalignment or binding of moving parts, breakage of parts and any other condition that may affect the power tool's operation. If damaged, have the power tool repaired before use.** Many accidents are caused by poorly maintained power tools.

**6. Keep cutting tools sharp and clean.** Properly maintained cutting tools with sharp cutting edges are less likely to bind and are easier to control.

**7. Use the power tool, accessories and tool bits, etc. in accordance with these instructions, taking into account the working conditions and the work to be performed.** Use of the power tool for operations different from those intended could result in a hazardous situation.

**8. Use clamps to secure your workpiece to a stable surface.** Holding a workpiece by hand or using your body to support it may lead to loss of control.

**9. KEEP GUARDS IN PLACE** and in working order.

### SERVICE

**1. Have your power tool serviced by a qualified repair person using only identical replacement parts.** This will ensure that the safety of the power tool is maintained.

### CALIFORNIA PROPOSITION 65 WARNING

Some dust created by power sanding, sawing, grinding, drilling, and other construction activities may contain chemicals, including lead, known to the State of California to cause cancer, birth defects, or other reproductive harm. Wash hands after handling. Some examples of these chemicals are:

- Lead from lead-based paints.
- Crystalline silica from bricks, cement, and other masonry products.
- Arsenic and chromium from chemically treated lumber.

Your risk from these exposures varies depending on how often you do this type of work. To reduce your exposure to these chemicals, work in a well-ventilated area with approved safety equipment such as dust masks specially designed to filter out microscopic particles.

# SPINDLE SANDER SAFETY WARNINGS

 **WARNING!** Do not let comfort or familiarity with the product replace strict adherence to product safety rules. Failure to follow the safety instructions may result in serious personal injury.

## SPINDLE SANDER SAFETY

**1. TOOL PURPOSE.** This sander is designed to sand wood or wood-like products only. Sanding or grinding other materials could result in fire, injury, or damage to the workpiece. Using the machine for any other purpose for which it is not designed may result in serious injuries, machine damage and voiding of the warranty.

**2. MACHINE MOUNTING.** For operation safety, the sander must be securely mounted onto a flat and stable surface or stand.

### 3. PERSONAL SAFETY.

- Always wear ANSI Z87.1-approved glasses with side shields, hearing protection and a dust mask.
- Do not wear loose clothing or jewelry, as they might get drawn in by the tool. Tie back long hair.
- DO NOT wear gloves while operating this machine.

**4. ELECTRIC CORDS.** Keep cords away from heat, oil, sharp edges, and moving parts of the tool. Have an electrician replace or repair damaged or worn cords immediately.

**5. TOOL & ACCESSORIES INSPECTION.** Before operation, check the tool and accessories for any damage or missing parts. Do not use the tool if any part is missing or damaged. Make sure all adjustments are correct and all connections are tight. Keep all guards in place.

### 6. SANDING ACCESSORIES.

- Do not use sanding sleeves or drums that are damaged, torn, or loose. Replace worn or damaged sanding sleeves before operation.
- Always unplug the unit before making adjustments or changing sandpaper, rubber drums or throat plates.
- Always use the throat plate that matches the diameter of the drum to minimize the gap between the drum and the throat plate opening; this will reduce the risk of personal injury.

### 7. WORKPIECE REQUIREMENTS.

- Only sand workpieces sturdy enough to withstand the force of the sanding spindle.
- Inspect the workpiece for imperfections, nails, staples, etc. before sanding. Never sand stock that has questionable imperfections or embedded foreign objects.
- When sanding a large workpiece, provide additional support. Do not sand with the workpiece unsupported.
- Sand only one workpiece at a time.

**8. PREVENTING ACCIDENTAL STARTING.** Make sure the power switch is in the OFF position prior to plugging in the machine. Always make sure the power switch is in the OFF position and the machine is unplugged when doing any cleaning, assembly, setup operations, or when not in use.

## **SPINDLE SANDER SAFETY WARNINGS**

 **WARNING!** Do not let comfort or familiarity with the product replace strict adherence to product safety rules. Failure to follow the safety instructions may result in serious personal injury.

9. Do not operate this tool until it is completely assembled and installed according to the instructions.

10. Remove scrap pieces and other objects from the table and sanding sleeve before turning ON the sander.

### **11. FEEDING THE WORKPIECE.**

- Allow spindle to reach full speed before feeding the workpiece. Do not turn on the machine while the sanding sleeve is contacting the workpiece.
- Be aware of the direction of the spindle's rotation (counterclockwise). Only feed the workpiece against the rotation of the spindle.
- Firmly hold the workpiece and lightly ease it against the spindle. Do not forcefully jam a workpiece into the sanding surface.

**12. DO NOT TOUCH MOVING PIECES.** Keep hands away from the drum during operation. If cleaning is necessary, use a brush to remove sawdust and chips instead of your hands.

13. Never perform layout, assembly or set-up work on the table while the sander is operating.

**14. TURNING OFF THE TOOL.** After turning off the sander, wait until the spindle comes to a complete stop before touching the workpiece or leaving the work area.

15. Always turn off and unplug the machine before cleaning, making adjustments or changing attachments. Accidental start-ups may occur if the tool is plugged in during an accessory change or adjustment.

**16. CLEANING.** Never use solvents to clean plastic parts. Solvents could dissolve or otherwise damage the material. Use only a soft damp cloth to clean plastic parts.

**These safety instructions can't possibly warn of every scenario that may arise with this tool, so always make sure to stay alert and use common sense during operation.**

# ELECTRICAL INFORMATION

## DOUBLE-INSULATED CHARGER

The tool's electrical system is double-insulated where two systems of insulation are provided. This eliminates the need for the usual three-wire grounded power cord. Double-insulated tools do not need to be grounded, nor should a means for grounding be added to the product. All exposed metal parts are isolated from the internal metal components with protecting insulation.

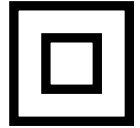

**IMPORTANT:** Servicing a double-insulated product requires extreme care and knowledge of the system, and should be done only by qualified service personnel using identical replacement parts. Always use original factory replacement parts when servicing.

**1. Polarized Plugs.** To reduce the risk of electric shock, this equipment has a polarized plug (one blade is wider than the other). This plug will fit in a polarized outlet only one way. If the plug does not fit fully in the outlet, reverse the plug. If it still does not fit, contact a qualified electrician to install a proper outlet. Do not modify the machine plug or the extension cord in any way.

**2. Ground fault circuit interrupter protection (GFCI)** should be provided on the circuit or outlet used for this power tool to reduce the risk of electric shock.

**3. Service and repair.** To avoid danger, electrical appliances must only be repaired by a qualified service technician using original replacement parts.

## GUIDELINES AND RECOMMENDATIONS FOR EXTENSION CORDS

When using an extension cord, be sure to use one heavy enough to carry the current your product will draw. An undersized cord will cause a drop in line voltage, resulting in loss of power and overheating. The table below shows the correct size to be used according to cord length and ampere rating. When in doubt, use a heavier cord. The smaller the gauge number, the heavier the cord.

AMPERAGE	REQUIRED GAUGE FOR EXTENSION CORDS			
	25 ft.	50 ft.	100 ft.	150 ft.
3.5A	18 gauge	16 gauge	16 gauge	14 gauge

**1. Examine extension cord before use.** Make sure your extension cord is properly wired and in good condition. Always replace a damaged extension cord or have it repaired by a qualified person before using it.

**2. Do not abuse extension cord.** Do not pull on cord to disconnect from receptacle; always disconnect by pulling on plug. Disconnect the extension cord from the receptacle before disconnecting the product from the extension cord. Protect your extension cords from sharp objects, excessive heat and damp/wet areas.

**3. Use a separate electrical circuit for your tool.** This circuit must not be less than a 12-gauge wire and should be protected with a 15A time-delayed fuse. Before connecting the motor to the power line, make sure the switch is in the OFF position and the electric current is rated the same as the current stamped on the motor nameplate. Running at a lower voltage will damage the motor.



# KNOW YOUR SPINDLE SANDER

## UNPACKING

Carefully remove the spindle sander from the packaging and place it on a sturdy, flat surface. Make sure to take out all contents and accessories. Do not discard the packaging until everything is removed. Check the packing list below to make sure you have all of the parts and accessories. If any part is missing or broken, please contact customer service at **1-800-232-1195** (M-F 8-5 CST), or email [techsupport@wenproducts.com](mailto:techsupport@wenproducts.com).

## TOOL PURPOSE

Spindle sanding is the preferred method of removing material from inside curves and irregular edges. The oscillating spindle moves up and down as it rotates to help smooth workpiece surfaces quickly and evenly. Refer to the diagram below to become familiarized with the parts and controls of your spindle sander.

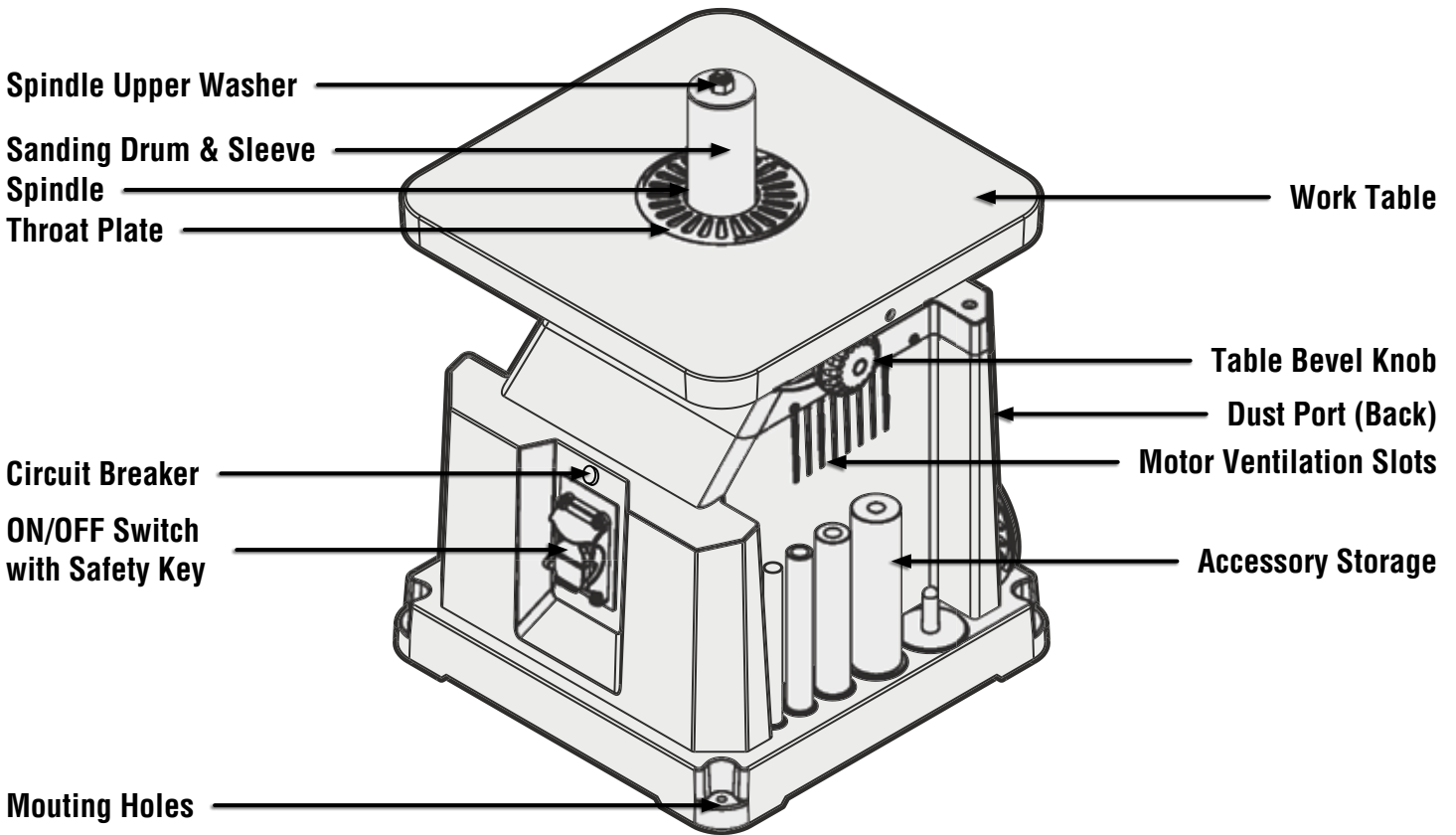

## CLEANING THE WORK TABLE SURFACE

Your sander's work table comes protected with a layer of anti-rust coating. Clean the rust-protected surfaces using a soft cloth, moistened with kerosene. Do not use gasoline or cellulose-based solvents such as paint thinner or lacquer thinner, as these will damage the painted surfaces.

After cleaning, apply a coat of paste wax to the table to prevent rust. Wipe all parts thoroughly with a clean, dry cloth.

# KNOW YOUR SPINDLE SANDER

## UNPACKING

Before using the spindle sander, you must configure the machine by installing the appropriate sanding drum, sanding sleeve, throat plate, and spindle washer for your operation. Check your packing list against the diagram below. If any part is damaged or missing, please contact our customer service at **1-(800) 232-1195**, M-F 8-5 CST or email us at [techsupport@wenproducts.com](mailto:techsupport@wenproducts.com).

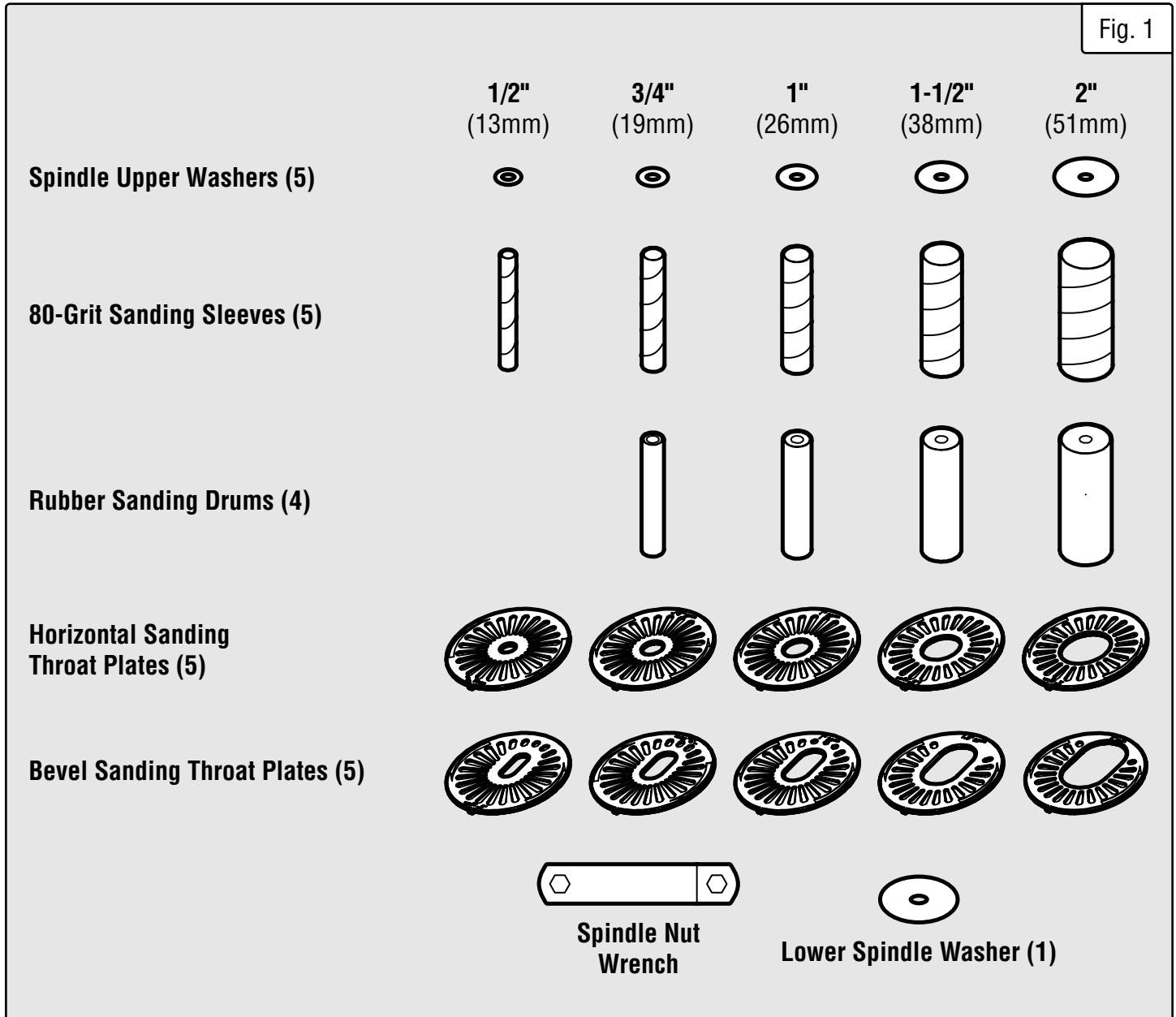

Sanding sleeves of various grits can be purchased from [wenproducts.com](http://wenproducts.com) by searching your product's model number **AT6535**.

## ASSEMBLY & ADJUSTMENTS

**⚠ WARNING!** To prevent accidental starting, make sure the machine is switched OFF and the power plug is disconnected before assembly, setting up or making adjustments.

### ACCESSORY SELECTION

Refer to the packing list diagram on page 10 to ensure that you are using the proper sizes of throat plates, drums and washers for each respective sanding sleeve. To ensure the workpiece can be properly supported and to minimize clearance, use the throat plate that matches the drum and sleeve that you'll be working with. The size of the throat plate is marked on the plate's surface. For horizontal sanding, use throat plates with circle openings; for bevel sanding, use plates with an oblong openings.

**NOTE:** The smallest size sanding sleeve does not include a drum. It goes directly onto the bare spindle.

### INSTALLING THE ACCESSORIES

1. Disconnect the machine from the power source.
2. Slide the lower spindle washer (Fig. 2 - 1) over the spindle shaft.
3. Install the preferred rubber drum (Fig. 2 - 2) onto the spindle shaft, followed by the corresponding sanding sleeve (Fig. 2 - 3) and throat plate (Fig. 2 - 4). Make sure the printed side of the throat plate is facing up.

**NOTE:** The 1/2" sleeve should be installed directly onto the spindle.

4. Secure the sanding accessories in place with the corresponding washer (Fig. 2 - 5). Tighten the spindle nut on top (Fig. 2 - 6) with the spindle nut wrench until the sanding drum creates equal pressure to all sides of the sanding sleeve. The sleeve should not be able to freely rotate without also rotating the sanding drum.

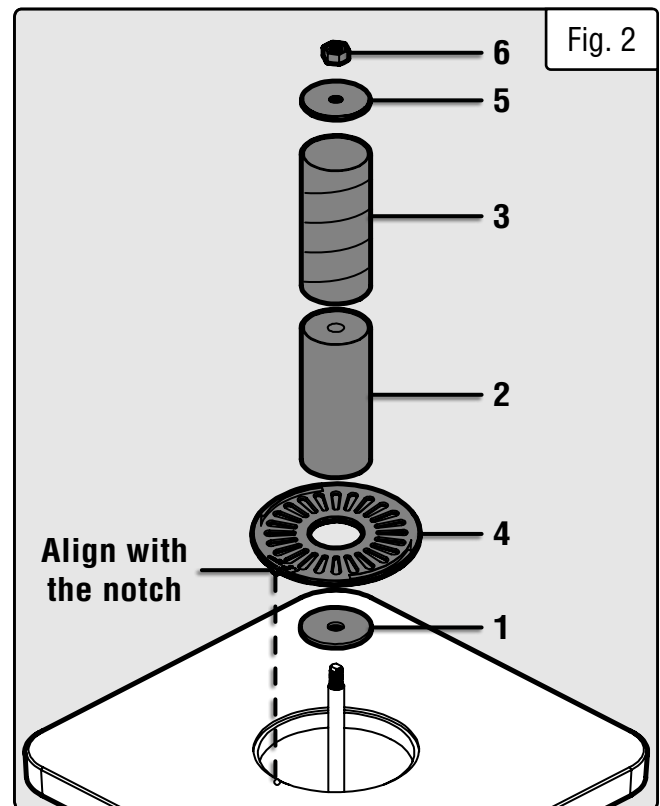

## ASSEMBLY & ADJUSTMENTS

**⚠ WARNING!** To prevent accidental starting, make sure the machine is switched OFF and the power plug is disconnected before assembly, setting up or making adjustments.

### MACHINE MOUNTING

For safe operation, the machine must be secured onto a flat, secure workbench or stand. The base of the machine has four 6 mm mounting holes. Place the sander on the mounting surface, and insert a pencil through the mounting holes to mark the hole locations. Remove the sander and drill out the mounting holes. Then align the sander base over the mounting holes and secure the machine using four mounting bolts, washers, locking washers and hex nuts (mounting hardware not included). Securely tighten the hex nuts.

For temporary mounting, secure the sander to a mobile mounting board and use 2 large C-Clamps to secure the mounting board to a solid surface.

**TIP:** Your spindle sander is compatible with the WEN 6588 Multipurpose Planer Stand, available at [wenproducts.com](http://wenproducts.com). Forget measuring and drilling holes on your workbench, simply mount your machine onto the stand with pre-drilled holes, and transport your machine around the workshop with ease.

### ADJUSTING THE WORK TABLE BEVEL

The work table has the capacity to tilt from 0 to 45 degrees for sanding bevels on your workpiece. For any bevel sanding operation, you must use the throat plate with an oblong-shaped opening (Fig. 3 - 1).

#### To adjust the table bevel:

1. Disconnect the machine from the power source.
2. Loosen the table bevel knobs (Fig. 3 - 2) on both sides of the sander.
3. Tilt the table until the pointer is indicating the desired angle on the bevel gauge.
4. Re-tighten both bevel knobs.

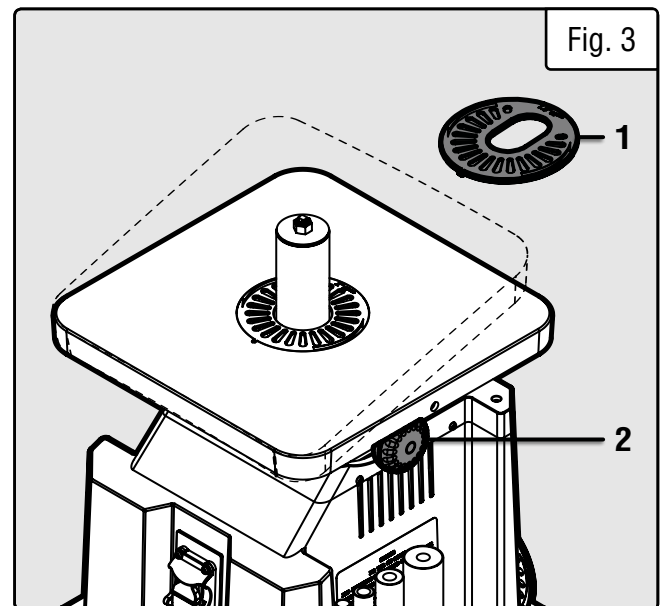

## ASSEMBLY & ADJUSTMENTS

### SQUARING THE TABLE TO THE SPINDLE

When sanding with the work table in the horizontal (0°) position, make sure that the table surface is square to the sanding spindle. With the sanding drum and sleeve installed, check the alignment using a machinist's or combination square. The square should be flat against the table and the spindle (Fig. 4). Periodically check for proper alignment between the table and spindle. If the table and spindle are not square, adjust as follow:

1. Check that the table is in the 0-degree position.
2. Loosen both table bevel knobs (Fig. 5 - 1).
3. Adjust the corresponding fine adjustment nut beneath the work table (Fig. 5 - 2) to bring the table perpendicular to the spindle.
4. Lock both table bevel knobs and use a square to re-check table/spindle alignment.
5. Repeat steps 2 - 4 until the table surface and sanding spindle are perpendicular.

### DUST COLLECTION

**⚠ WARNING!** Sanding operations are dusty and can produce particles that are harmful to your health. Always wear a dust mask and use an adequate dust collection system.

#### To connect a dust collection system to the machine:

1. Fit a 2-inch dust hose (not included) over the dust port (Fig. 5 - 3) and secure the hose in place with a hose clamp as needed.
2. Tug the hose to make sure the fitting is tight. A tight fit is necessary for proper performance.
3. Connect the other end of the dust hose to the dust collection system of your choice. A dust port adapter may be needed (not included), depending on the inlet size of your dust extractor.

**NOTE:** Failure to use a dust collector can cause sawdust to build up in the machine, possibly leading to premature failure. Failure to use a dust collector will void the warranty. Keep your sander clean!

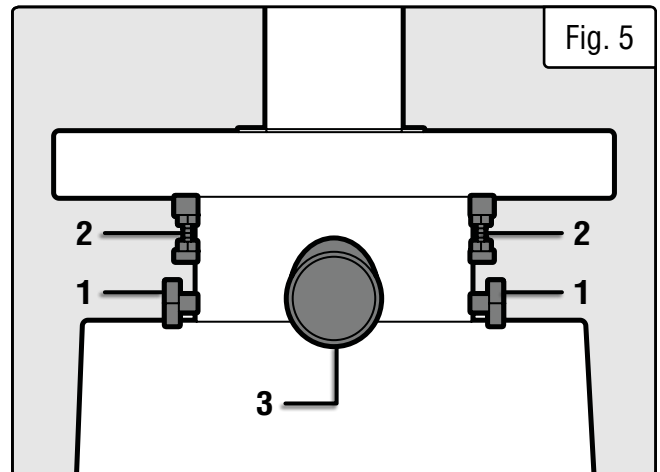
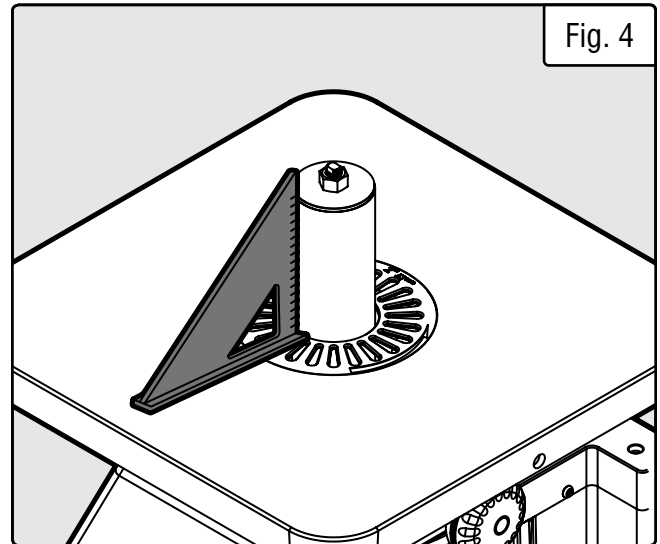

## OPERATION

**⚠ WARNING!** Do not plug in or turn on the tool until it is fully assembled according on the instructions. Failure to follow the safety instructions may result in serious personal injury.

### ON/OFF SWITCH WITH SAFETY KEY

The keyed ON/OFF switch (Fig. 6) is intended to prevent unauthorized use of the sander.

1. To turn the sander ON, insert the safety key into the key slot in the center of the switch. Lift the switch up to turn ON the sander.
2. To turn the sander OFF, push switch down. Remove the safety key when the sander has come to a complete stop by gently pulling the key out.

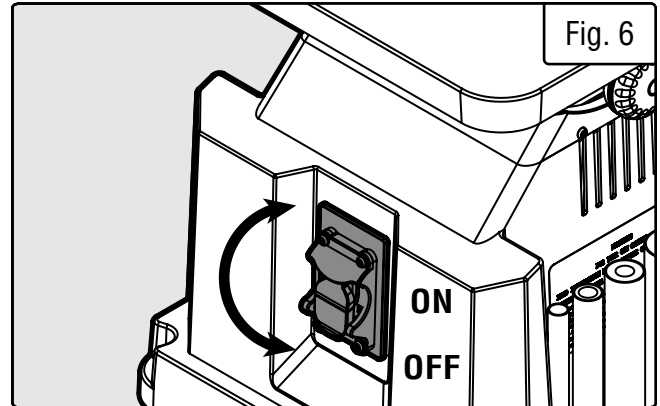

**⚠ WARNING!** Remove the safety key whenever the sander is not in use. Place the key in a safe place and out of the reach of children.

### OPERATING THE SPINDLE SANDER

1. Make sure that the machine has been securely mounted, and all accessories have been properly installed according to the instructions in the "ASSEMBLY & ADJUSTMENTS" section.
2. Plug in and turn ON the sander. Let the spindle reach full speed.
3. Maintain a firm grip with both hands on the workpiece for maximum control. Slowly guide the workpiece against the rotation of the spindle (Fig. 7).

**NOTE:** The spindle rotates in a counterclockwise direction. Guide the workpiece from the right to left. If you guide the workpiece in the opposite direction, the forces of the spinning sanding sleeve will tend to throw or bounce the workpiece away from the sanding sleeve, possibly resulting in injuries.

4. Maintain downward pressure on the workpiece against the table, gently working it along the sanding sleeve until the desired curve has been created. Do not force the workpiece against the sanding sleeve.
5. When you are finished, turn OFF the sander and wait for the spindle to come to a complete stop.
6. Remove the safety key and unplug the machine from the outlet. Follow the maintenance instructions on the next page to clean and maintain your sander.

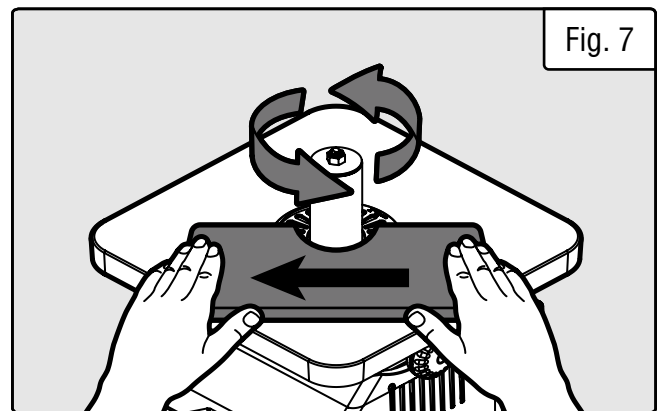

# MAINTENANCE

**⚠ WARNING!** To avoid accidents, turn OFF and unplug the tool from the electrical outlet before cleaning, adjusting, or performing any maintenance or lubrication work.

**⚠ WARNING!** Any attempt to repair or replace electrical parts on this tool may be hazardous. Servicing of the tool must be performed by a qualified technician. When servicing, use only identical WEN replacement parts. Use of other parts may be hazardous or induce product failure.

## ROUTINE INSPECTION

Before each use, inspect the general condition of the tool. If any of these following conditions exist, do not use until parts are replaced or the sharpener is properly repaired.

### Check for:

- Loose hardware or improper mounting,
- Misalignment or binding of moving parts,
- Damaged cord/electrical wiring,
- Cracked or broken parts, and
- Any other condition that may affect its safe operation

## CLEANING & STORAGE

1. After every operation, use a vacuum to remove dust and chips from the tool surfaces, motor housing and work area. Keep the ventilation openings free from dust and debris to prevent the motor from overheating.
2. Wipe the tool surfaces clean with a soft cloth or brush. Make sure water does not get into the tool.
3. Periodically, remove the throat plate and lower spindle washer and remove any dust accumulation in the throat plate area.

**⚠ CAUTION!** Most plastics are susceptible to damage from various types of commercial solvents. Do not use any solvents or cleaning products that could damage the plastic parts. Some of these include but are not limited to: gasoline, carbon tetrachloride, chlorinated cleaning solvents, and household detergents that contain ammonia.

4. Store the tool in a clean and dry place away from the reach of children. Store sanding accessories away from extremely hot/dry temperatures. Do not bend or fold the sanding sleeves.

## LUBRICATION

All ball bearings are sealed and permanently lubricated. No further lubrication is required.

## PRODUCT DISPOSAL

Used power tools should not be disposed of together with household waste. This product contains electronic components that should be recycled. Please take this product to your local recycling facility for responsible disposal and to minimize its environmental impact.

## TROUBLESHOOTING GUIDE

**⚠ WARNING!** Stop using the tool immediately if any of the following problems occur. Repairs and replacements should only be performed by an authorized technician. For any questions, please contact our customer service at **1-(800) 232-1195**, M-F 8-5 CST or email us at [techsupport@wenproducts.com](mailto:techsupport@wenproducts.com).

PROBLEM	CAUSE	SOLUTION
<b>Sander does not turn on.</b>	1. Power cord or extension cord damaged or not properly plugged in.	1. Check the power cord, extension cord, power plug and the power outlet. Make sure the tool is properly plugged in. Do not use the if any cord is damaged.
	2. Safety key is removed from power switch.	2. Insert the safety key into the power switch.
	3. Defective power switch, defective motor or wiring, short circuit or loose connections.	3. Stop using the tool and contact customer service at <b>1-(800) 232-1195</b> , M-F 8-5 CST for assistance. Repairs must be done by a qualified technician.
<b>Motor overheats.</b>	1. Motor overloaded.	1. Reduce load on motor - reduce pressure on the workpiece being sanded.
	2. Extension cord too long with an insufficient gauge.	2. Utilize an extension cord of appropriate gauge and length or plug tool directly into outlet (see page 8).
<b>Sanding grains easily rub off.</b>	1. Sanding sleeve has been stored in an incorrect environment.	1. Store sanding accessories away from extremely hot/dry temperatures.
	2. Sanding sleeve has been damaged or folded.	2. Store sanding accessories flat—not bent or folded.
<b>Deep sanding grooves or scars in workpiece.</b>	1. Sanding sleeve grit is too coarse for the desired finish.	1. Use a finer-grit sanding accessory.
	2. Workpiece sanded across the grain.	2. Sand with the grain of the wood.
	3. Too much sanding force.	3. Reduce pressure on workpiece while sanding.
	4. Workpiece held still against sanding surface for too long.	4. Keep workpiece moving while sanding on the sanding sleeve.
<b>Burns on workpiece.</b>	1. Using a sanding grit that is too fine.	1. Use a coarser-grit sanding accessory.
	2. Using too much pressure.	2. Reduce sanding pressure on workpiece.
	3. Work held still for too long.	3. Do not keep workpiece in one place for too long.
	4. Sanding sleeve loaded with debris.	4. Clean or replace the sanding sleeve.
<b>Sanding surface clogs quickly.</b>	1. Too much pressure against sleeve.	1. Clean sanding sleeve. Reduce pressure on workpiece while sanding.
	2. Sanding softwood.	2. Use different stock/sanding accessories, or accept that this will happen and plan on cleaning or replacing sleeves frequently.
<b>Sander vibrates excessively or has noisy operation.</b>	1. Sanding sleeve out of balance or is loose.	1. Ensure sleeve is properly installed.
	2. Motor or internal components loose.	2. Inspect/replace damaged bolts/nuts and retighten with thread-locking fluid.
	3. Machine not properly mounted.	3. Tighten mounting hardware.
	4. Faulty motor bearings.	4. Test by rotating shaft; rotational grinding/loose shaft requires bearing replacement.
<b>Sanding stops oscillating.</b>	1. Spindle drive belt is broken and requires replacement.	1. Contact customer service at <b>1-(800) 232-1195</b> , M-F 8-5 CST for assistance. Repairs must be done by a qualified technician.



# EXPLODED VIEW & PARTS LIST

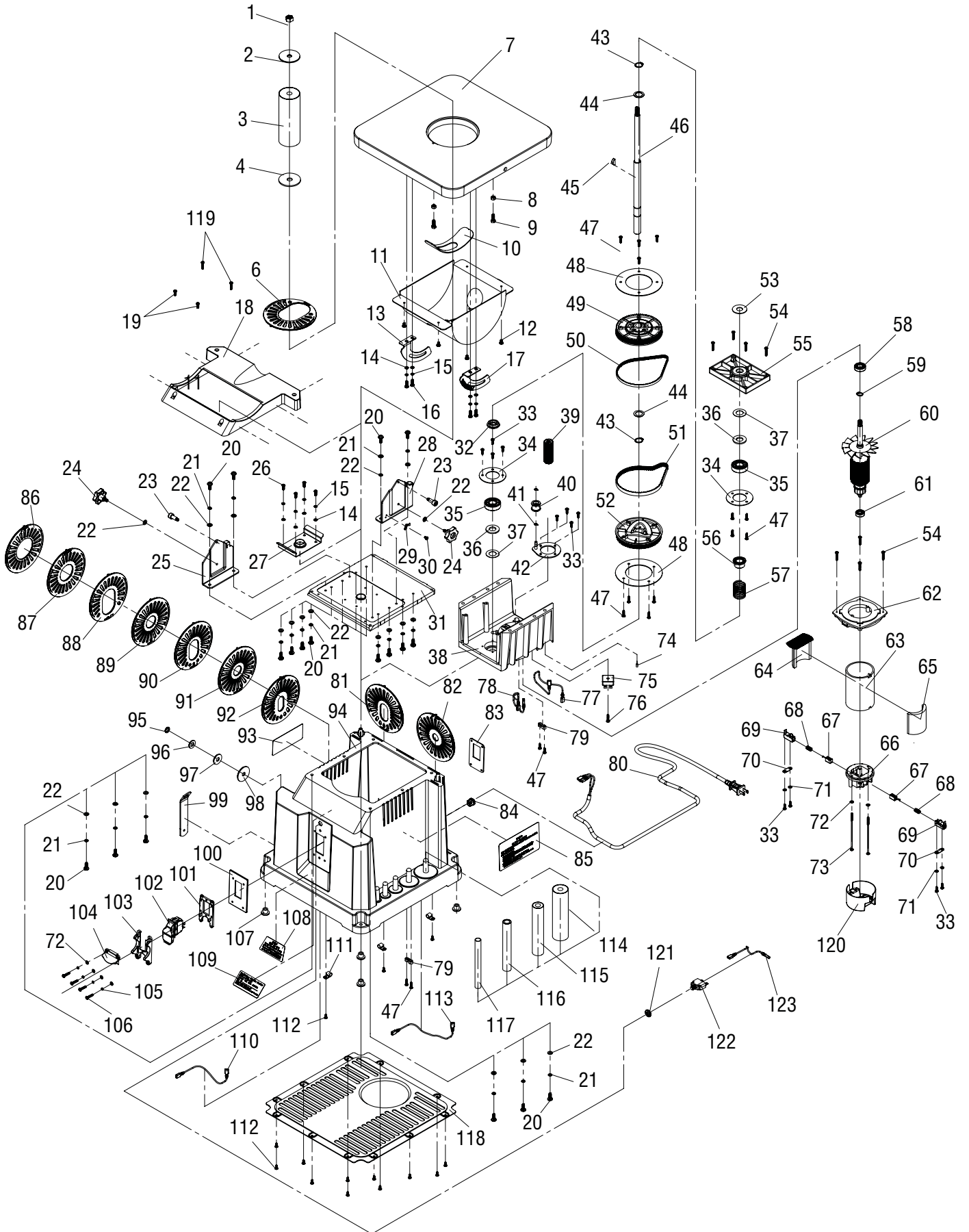

## **EXPLODED VIEW & PARTS LIST**

No.	Part No.	Description	Qty.
1	AT6535-001	Hex Nut M10	1
2	AT6535-002	(2") Upper Washer	1
3	AT6535-003	(2") Rubber Drum	1
4	AT6535-004	Lower Washer	1
6	AT6535-006	(2") Throat Plate, Bevel	1
7	AT6535-007	Iron Work Table	1
8	AT6535-008	Hex Nut M6	2
9	AT6535-009	Hex Screw M6x18	2
10	AT6535-010	Dust Guard	1
11	AT6535-011	Dust Box	1
12	AT6535-012	Screw M5x8	4
13	AT6535-013	Right Bevel Plate	1
14	AT6535-014	Flat Washer Ø5	8
15	AT6535-015	Spring Washer Ø5	8
16	AT6535-016	Screw M5x16	4
17	AT6535-017	Left Bevel Plate	1
18	AT6535-018	Cover	1
19	AT6535-019	Screw M4x10	6
20	AT6535-020	Screw M6x16	18
21	AT6535-021	Spring Washer Ø6	18
22	AT6535-022	Flat Washer Ø6	20
23	AT6535-023	Stepped Screw	2
24	AT6535-024	Table Bevel Knob	2
25	AT6535-025	Left Locating Plate	1
26	AT6535-026	Screw M5x12	4
27	AT6535-027	Dust Box Holder	1
28	AT6535-028	Right Locating Plate	1
29	AT6535-029	Angle Pointer	1
30	AT6535-030	Screw M4x6	1
31	AT6535-031	Motor Fixed Plate	1
32	90225-058	Rubber Washer	1
33	90225-018	Screw ST4.2x13	12

No.	Part No.	Description	Qty.
34	90225-062	Bearing Cover	2
35	90225-063	Bearing 6203ZZ	2
36	90225-065	Felted Wool Washer	2
37	90225-064	Rubber Washer	2
38	AT6535-038	Pulley Support	1
39	90225-015	Motor Pulley	1
40	90225-017	Tension Pulley	1
41	90225-016	Spring Washer, 6mm	2
42	90225-019	Locating Plate	1
43	90225-050	Washer Ø17	2
44	90225-051	Washer	2
45	90225-056	Woodruff Key 5x19	1
46	AT6535-046B	Spindle	1
47	AT6535-047	Screw ST4.2x16	16
48	90225-053	Pulley Plate	2
49	90225-054	Driving Pulley	1
50	90225-013	Belt, 3/8" x 160XL	1
51	90225-014	Belt, 1/4" x 160XL	1
52	90225-057	Passive Pulley	1
53	6523-076	Flat Washer, 6mm	1
54	AT6535-054	Screw ST4.2x23	8
55	90225-042	Bearing Cover	1
56	90225-048	Bearing Sleeve Large	1
57	90225-049	Compression Spring	1
58	90225-026	Bearing 6001ZZ	1
59	90225-027	Elastic Washer Ø12	1
60	90225-028	Rotor	1
61	AT6535-061	Bearing 608	1
62	90225-030	Connecting Plate	1
63	90225-031	Stator	1
64	6523-066	Magnetic Shoe 1	1
65	6523-067	Magnetic Shoe 2	1
66	90225-032	Rear Cover	1
67	90225-034	Carbon Brush	2

## EXPLODED VIEW & PARTS LIST

No.	Part No.	Description	Qty.
68	90225-035	Carbon Brush Spring	2
69	90225-033	Brush Holder	2
70	90225-036	Brush Clamp	2
71	90225-037	Washer Ø4	4
72	90225-039	Flat Washer Ø4	6
73	90225-040	Screw ST4.2x110	2
74	AT6535-074	Rubber Key	1
75	90225-069	Rectifier Bridge	1
76	90225-070	Screw ST4.2x19	5
77	AT6535-077	Connecting Wire 1	1
78	AT6535-078	Connecting Wire 2	1
79	AT6535-079	Cable Clamp	2
80	AT6535-080	Power Cord & Plug	1
81	AT6535-081	(1/2") Throat Plate, Bevel	1
82	AT6535-082	(1/2") Horizontal Throat Plate	1
83	AT6535-083	Switch Locating Plate	1
84	AT6535-084	Power Cord Holder	1
85	AT6535-085	Warning Label	1
86	AT6535-086	(2") Throat Plate, Horizontal	1
87	AT6535-087	(1-1/2") Throat Plate, Horizontal	1
88	AT6535-088	(1-1/2") Throat Plate, Bevel	1
89	AT6535-089	(1") Throat Plate, Horizontal	1
90	AT6535-090	(1") Throat Plate, Bevel	1
91	AT6535-091	(3/4") Throat Plate, Horizontal	1
92	AT6535-092	(3/4") Throat Plate, Bevel	1
93	AT6535-093	Warning Label	1

No.	Part No.	Description	Qty.
94	AT6535-094	Plastic Base	1
95	AT6535-095	(1/2") Upper Washer	1
96	AT6535-096	(3/4") Upper Washer	1
97	AT6535-097	(1") Upper Washer	1
98	AT6535-098	(1-1/2") Upper Washer	1
99	AT6535-099	Spindle Nut Wrench	1
100	AT6535-100	Switch Retainer Plate	1
101	AT6535-101	Switch Locating Piece (Lower)	1
102	AT6535-102	ON/OFF Switch	1
103	AT6535-103	Switch Locating Piece (Upper)	1
104	AT6535-104	Auxiliary Locating Ring	1
105	AT6535-105	Spring Washer Ø4	4
106	AT6535-106	Screw M4x19	4
107	AT6535-107	Rubber Foot	4
108	AT6535-108	Brand Label	1
109	AT6535-109	Specifications Label	1
110	90225-071	Connecting Wire	1
111	AT6535-111	Clamp	3
112	AT6535-112	Screw ST4.2x10	14
113	90225-072	Connecting Wire	1
114	AT6535-114	(1-1/2") Rubber Drum	1
115	AT6535-115	(1") Rubber Drum	1
116	AT6535-116	(3/4") Rubber Drum	1
118	AT6535-118	Base Plate	1
120	6510-116	Motor Cover	1
121	6510-117	Circuit Breaker Nut	1
122	6510-118	Circuit Breaker, 4A	1
123	6510-119	Wire Lead	1

**NOTE:** Replacement parts can be purchased from [wenproducts.com](http://wenproducts.com), or by calling our customer service at **1-(800) 232-1195**, M-F 8-5 CST. Parts and accessories that wear down over the course of normal use (e.g. sanding sleeves, sanding drums, carbon brushes, etc.) are not covered by the two-year warranty.

# **WARRANTY STATEMENT**

WEN Products is committed to building tools that are dependable for years. Our warranties are consistent with this commitment and our dedication to quality.

## **LIMITED WARRANTY OF WEN PRODUCTS FOR HOME USE**

GREAT LAKES TECHNOLOGIES, LLC (“Seller”) warrants to the original purchaser only, that all WEN consumer power tools will be free from defects in material or workmanship during personal use for a period of two (2) years from date of purchase or 500 hours of use; whichever comes first. Ninety days for all WEN products if the tool is used for professional or commercial use. Purchaser has 30 days from the date of purchase to report missing or damaged parts.

SELLER’S SOLE OBLIGATION AND YOUR EXCLUSIVE REMEDY under this Limited Warranty and, to the extent permitted by law, any warranty or condition implied by law, shall be the replacement of parts, without charge, which are defective in material or workmanship and which have not been subjected to misuse, alteration, careless handling, misrepair, abuse, neglect, normal wear and tear, improper maintenance, or other conditions adversely affecting the Product or the component of the Product, whether by accident or intentionally, by persons other than Seller. To make a claim under this Limited Warranty, you must make sure to keep a copy of your proof of purchase that clearly defines the Date of Purchase (month and year) and the Place of Purchase. Place of Purchase must be a direct vendor of Great Lakes Technologies, LLC. Purchasing through third party vendors, including but not limited to garage sales, pawn shops, resale shops, or any other secondhand merchant, voids the warranty included with this product. Contact [techsupport@wenproducts.com](mailto:techsupport@wenproducts.com) or 1-800-232-1195 with the following information to make arrangements: your shipping address, phone number, serial number, required part numbers, and proof of purchase. Damaged or defective parts and products may need to be sent to WEN before the replacements can be shipped out.

Upon the confirmation of a WEN representative, your product may qualify for repairs and service work. When returning a product for warranty service, the shipping charges must be prepaid by the purchaser. The product must be shipped in its original container (or an equivalent), properly packed to withstand the hazards of shipment. The product must be fully insured with a copy of the proof of purchase enclosed. There must also be a description of the problem in order to help our repairs department diagnose and fix the issue. Repairs will be made and the product will be returned and shipped back to the purchaser at no charge for addresses within the contiguous United States.

THIS LIMITED WARRANTY DOES NOT APPLY TO ITEMS THAT WEAR OUT FROM REGULAR USAGE OVER TIME, INCLUDING BELTS, BRUSHES, BLADES, BATTERIES, ETC. ANY IMPLIED WARRANTIES SHALL BE LIMITED IN DURATION TO TWO (2) YEARS FROM DATE OF PURCHASE. SOME STATES IN THE U.S. AND SOME CANADIAN PROVINCES DO NOT ALLOW LIMITATIONS ON HOW LONG AN IMPLIED WARRANTY LASTS, SO THE ABOVE LIMITATION MAY NOT APPLY TO YOU.

IN NO EVENT SHALL SELLER BE LIABLE FOR ANY INCIDENTAL OR CONSEQUENTIAL DAMAGES (INCLUDING BUT NOT LIMITED TO LIABILITY FOR LOSS OF PROFITS) ARISING FROM THE SALE OR USE OF THIS PRODUCT. SOME STATES IN THE U.S. AND SOME CANADIAN PROVINCES DO NOT ALLOW THE EXCLUSION OR LIMITATION OF INCIDENTAL OR CONSEQUENTIAL DAMAGES, SO THE ABOVE LIMITATION OR EXCLUSION MAY NOT APPLY TO YOU.

THIS LIMITED WARRANTY GIVES YOU SPECIFIC LEGAL RIGHTS, AND YOU MAY ALSO HAVE OTHER RIGHTS WHICH VARY FROM STATE TO STATE IN THE U.S., PROVINCE TO PROVINCE IN CANADA AND FROM COUNTRY TO COUNTRY.

THIS LIMITED WARRANTY APPLIES ONLY TO ITEMS SOLD WITHIN THE UNITED STATES OF AMERICA, CANADA AND THE COMMONWEALTH OF PUERTO RICO. FOR WARRANTY COVERAGE WITHIN OTHER COUNTRIES, CONTACT THE WEN CUSTOMER SUPPORT LINE. FOR WARRANTY PARTS OR PRODUCTS REPAIRED UNDER WARRANTY SHIPPING TO ADDRESSES OUTSIDE OF THE CONTIGUOUS UNITED STATES, ADDITIONAL SHIPPING CHARGES MAY APPLY.