

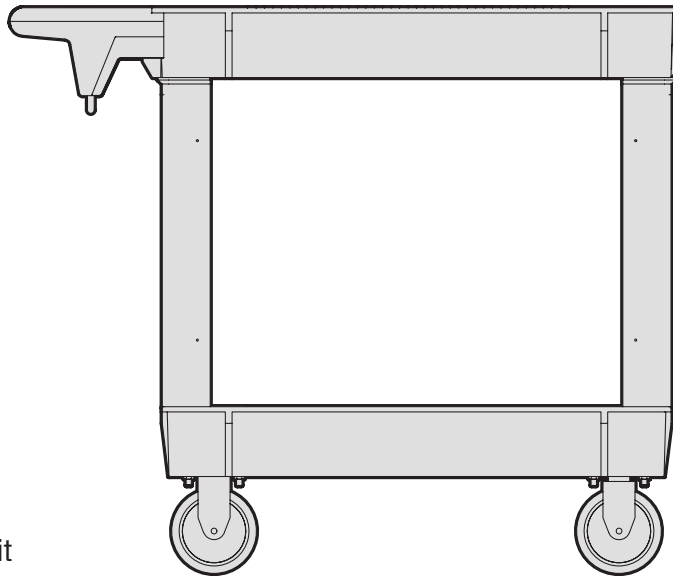

MODEL 73009

SERVICE CART



For replacement parts visit
WENPRODUCTS.COM

IMPORTANT:

Your new tool has been engineered and manufactured to WEN's highest standards for dependability, ease of operation, and operator safety. When properly cared for, this product will supply you years of rugged, trouble-free performance. Pay close attention to the rules for safe operation, warnings, and cautions. If you use your tool properly and for its intended purpose, you will enjoy years of safe, reliable service.

NEED HELP? CONTACT US!

Have product questions? Need technical support?
Please feel free to contact us at:



800-232-1195 (M-F 8am-5pm CST)



techsupport@wenproducts.com



WENPRODUCTS.COM

NOTICE: Please refer to wenproducts.com for the most up-to-date instruction manual.

TABLE OF CONTENTS

Specifications.....	2
Introduction	3
General Safety Rules	4
Know Your Service Cart.....	5
Assembly	6
Exploded View & Parts List	8
Warranty Statement.....	9

SPECIFICATIONS

Model Number	73009
Maximum Capacity	500 lbs (evenly distributed)
Upper Tray Inner Dimensions	30" L x 15" W x 2-7/8" H
Lower Tray Inner Dimensions	29" L x 15" W x 2-7/8" H
Wheel Diameter	4-7/8"
Casters	Two Fixed Wheels, Two Swivel Wheels

INTRODUCTION

Thanks for purchasing the WEN Service Cart. We know you are excited to put your tool to work, but first, please take a moment to read through the manual. Safe operation of this tool requires that you read and understand this operator's manual and all the labels affixed to the tool. This manual provides information regarding potential safety concerns, as well as helpful assembly and operating instructions for your tool.

 **WARNING:** Indicates danger, warning, or caution. The safety symbols and the explanations with them deserve your careful attention and understanding. Always follow the safety precautions to reduce the risk of fire, electric shock and personal injury. However, please note that these instructions and warnings are not substitutes for proper accident prevention measures.

NOTE: The following safety information is not meant to cover all possible conditions and situations that may occur. WEN reserves the right to change this product and specifications at any time without prior notice.

Keep this manual available to all users during the entire life of the tool and review it frequently to maximize safety for both yourself and others.

GENERAL SAFETY RULES

Safety is a combination of common sense, staying alert, and knowing how your item works. SAVE THESE SAFETY INSTRUCTIONS.

⚠ WARNING: Read and understand all warnings, cautions and operating instructions before using this tool. Failure to follow all instructions listed below may result in personal injury and tool damage.

1. **READ** and become familiar with this entire instruction manual. **LEARN** the tool's applications, limitations, and possible hazards.
2. **KEEP WORK AREA CLEAN.** Cluttered areas invite injuries and accidents.
3. **OBSERVE** work area conditions. Keep work area well lit.
4. **ALWAYS** keep your work area clean, uncluttered, and well lit. **DO NOT** work on floor surfaces that are slippery with sawdust or wax.
5. **STORE IDLE EQUIPMENT.** When not in use, store the service cart in a safe and clean location. Always secure products and keep out of reach of children.
6. **USE THE RIGHT PRODUCT FOR THE JOB.** There are certain applications for which this item was designed. Do not modify it and do not use it for a purpose for which it was not intended.
7. **CHECK FOR DAMAGED PARTS.** Before using any product, any part that appears damaged should be carefully checked to determine that it will operate properly and perform its intended function. Check for any broken or damaged parts and any other conditions that may affect its operation. Replace or repair damaged or worn parts immediately.
8. **WHEN SERVICING** use only identical replacement parts and accessories. Using any other parts will void the warranty.
9. **DO NOT** operate the tool if you are under the influence of drugs, alcohol, or medication that may affect your ability to properly use the tool.
10. **USE EYE PROTECTION.** Always wear ANSI approved impact safety goggles.
11. **DO NOT EXCEED THE PRODUCT'S MAXIMUM LOAD CAPACITY.** Always keep weight evenly distributed.
12. **ONLY USE ON A FLAT SURFACE** capable of supporting the item with its maximum capacity load. It is easy to lose control if attempting to pull a load on a sloping or uneven surface.
13. **DO NOT ALLOW CHILDREN TO PLAY ON,** stand upon or climb on this item. It is not intended for carrying people or animals.
14. **ALWAYS CHECK HARDWARE** and assembled parts after assembling. All connections should be tight.

KNOW YOUR SERVICE CART

PACKING LIST

Check your packing list against the diagram below. If any part is damaged or missing, please contact our customer service at (800) 232-1195, M-F 8-5 CST or email us at techsupport@wenproducts.com.

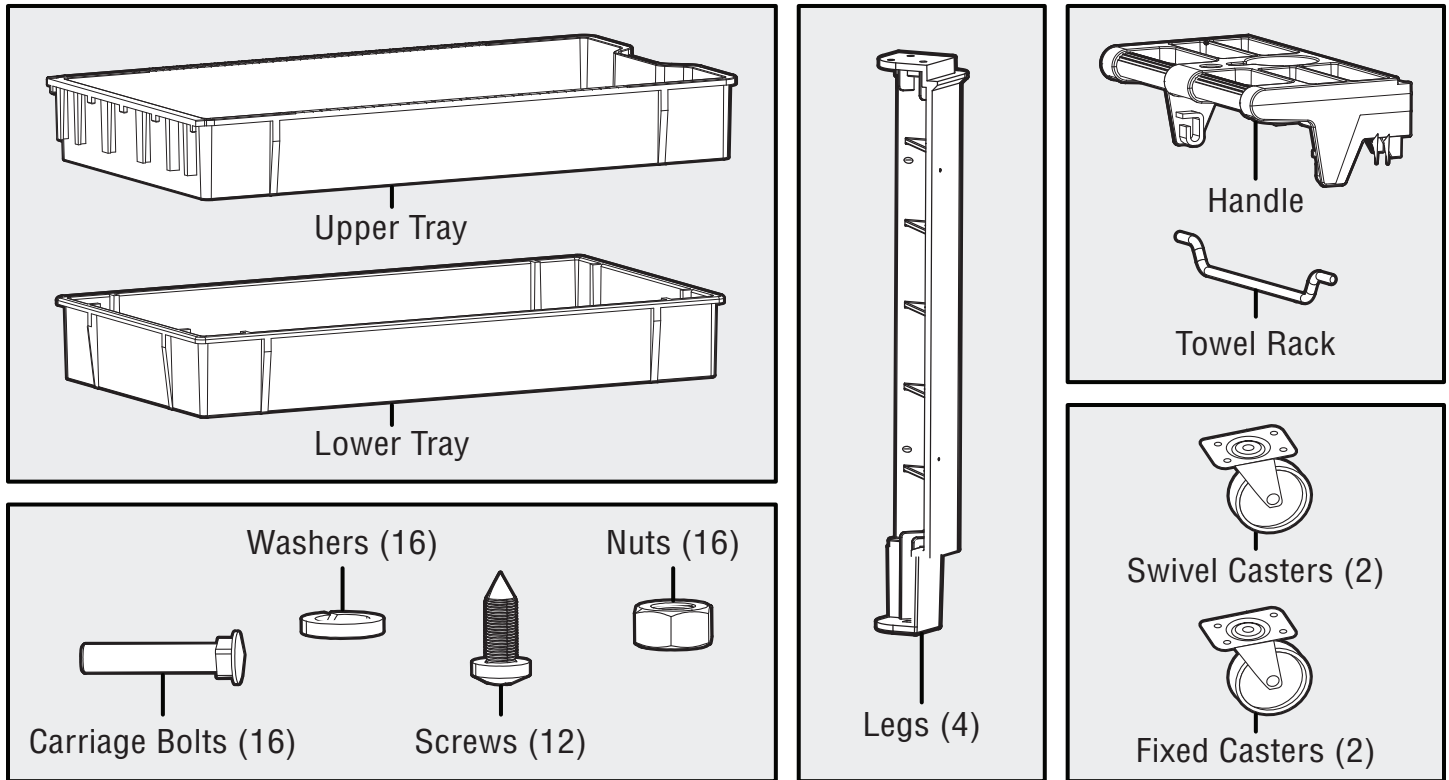

TOOL PURPOSE

Service Carts are heavy-duty mobile storage stations that help carry the load of your work. Refer to the following diagram to become familiarized with all the parts and controls of your service cart. The components will be referred to later in the manual for assembly and operation instructions.

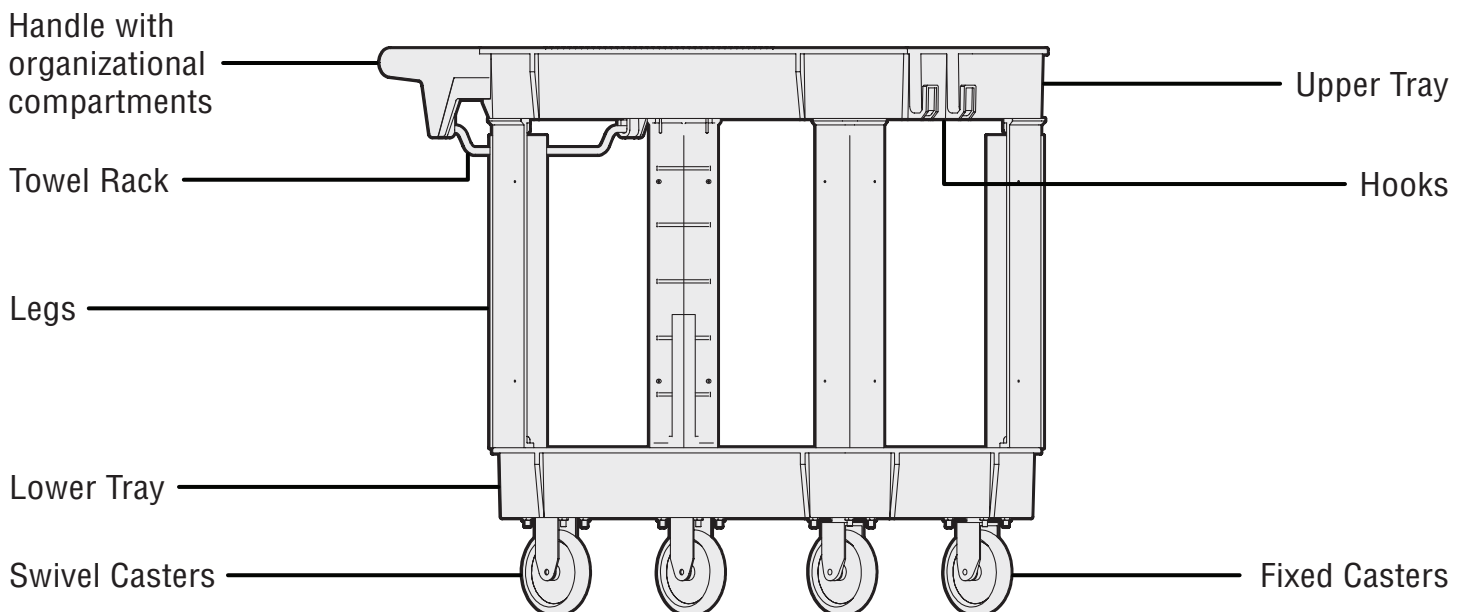

ASSEMBLY

1. Place the upper tray (Fig. 1 - 1) upside-down on a flat work surface.

2. Turn the push handle (Fig. 1 - 2) upside down with the cup holder towards the tray. Using a rubber mallet, tap the push handle down into the grooves on the tray. Make sure the handle is all the way on the tray.

NOTE: To overcome the friction between the two plastic surfaces, rub a little petroleum jelly onto the grooved surface. The two parts should slide together with a few gentle taps of the rubber mallet.

3. Locate two of the legs (Fig. 2 - 1), taking note of the positions of the bottom flanges. Place one nearest the handle and the other diagonally across the shelf tray corner. Using a rubber mallet, tap the legs onto the upper tray until the tab with the three screw holes is in contact with the shelf tray. Repeat this process with the other two legs so all four legs are in solid contact with the shelf tray.

4. Insert and tighten three screws (Fig. 2 - 2) per leg so that the legs are secured in the shelf tray.

5. Now for the lower tray (Fig. 3 - 1). Turn the shelf tray upside down and place it onto the four legs (Fig. 3 - 2). The flanges on the four legs should fit into the depressions in this shelf tray. If all 12 screws were correctly secured through the four legs into the shelf tray, everything should fit together. Gently tap shelf tray onto the four legs until the tabs and shelf tray depressions are in contact with each other.

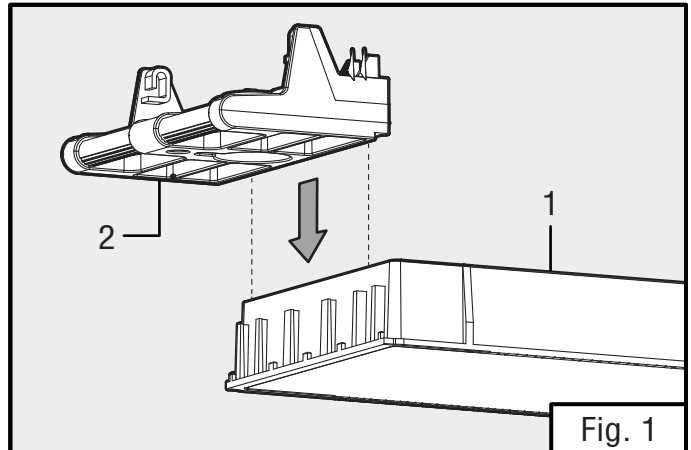

Fig. 1

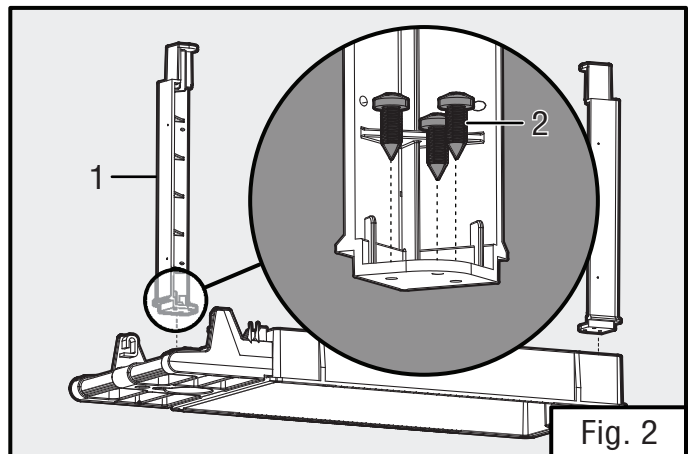

Fig. 2

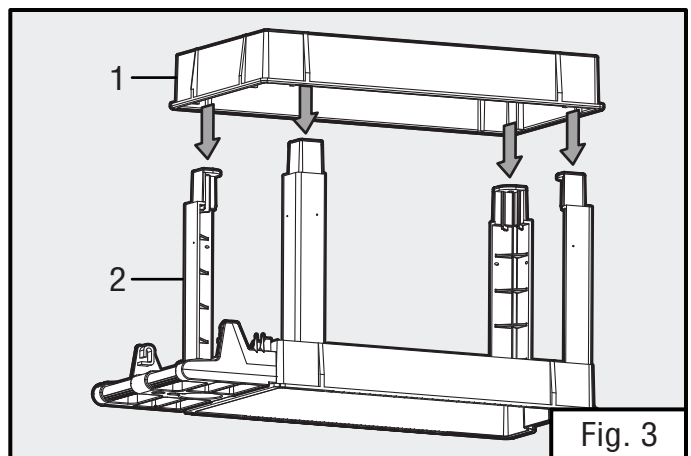

Fig. 3

ASSEMBLY

6. Insert the carriage bolts (Fig. 4 - 1) up through the leg tabs and the shelf tray. Attach the casters (Fig. 5 - 1) by first hand tightening the washers (Fig. 5 - 2) and nuts (Fig. 5 - 3). Once all four casters are in place, go back and use an adjustable wrench to make sure all nuts and bolts are fully tightened and secure.

NOTE: To maximize control, we suggest installing the fixed casters on the same side as the handle, while the swivel casters go on the opposite side of the cart. However, if you prefer to have them the opposite way in order to make sharper turns and pivots, that will also work.

7. Turn service cart upright and install the towel rack (Fig. 6 - 1). Make certain all hardware is tight and that the casters roll properly before adding any weight onto the cart.

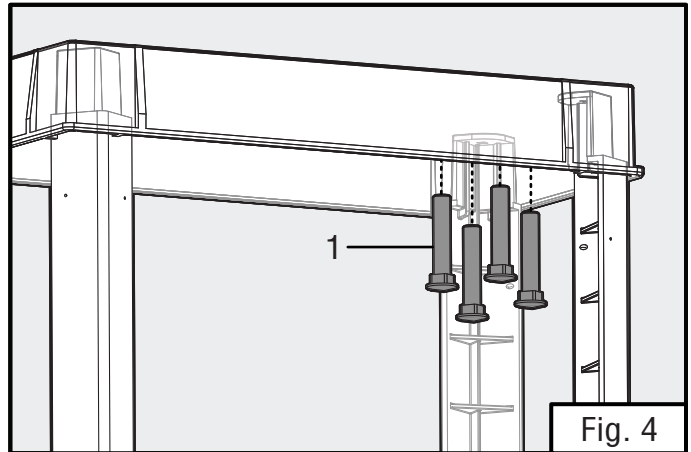

Fig. 4

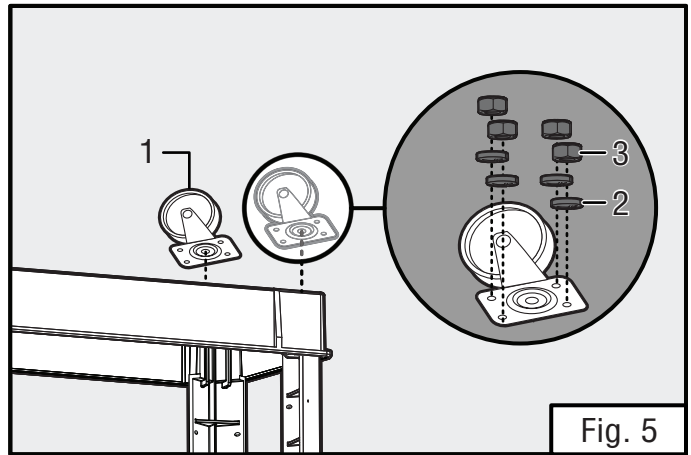

Fig. 5

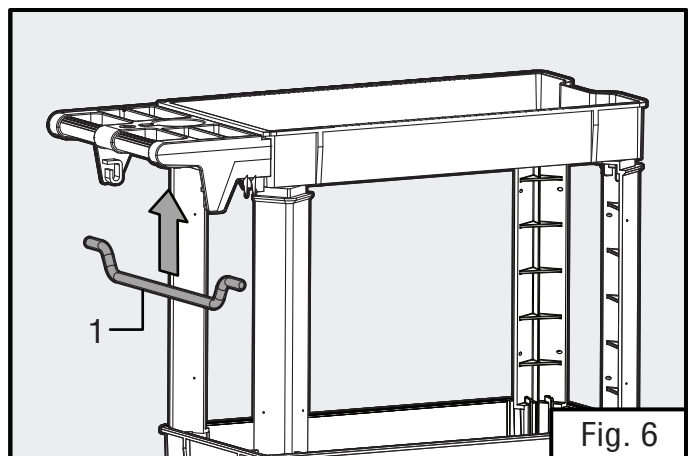
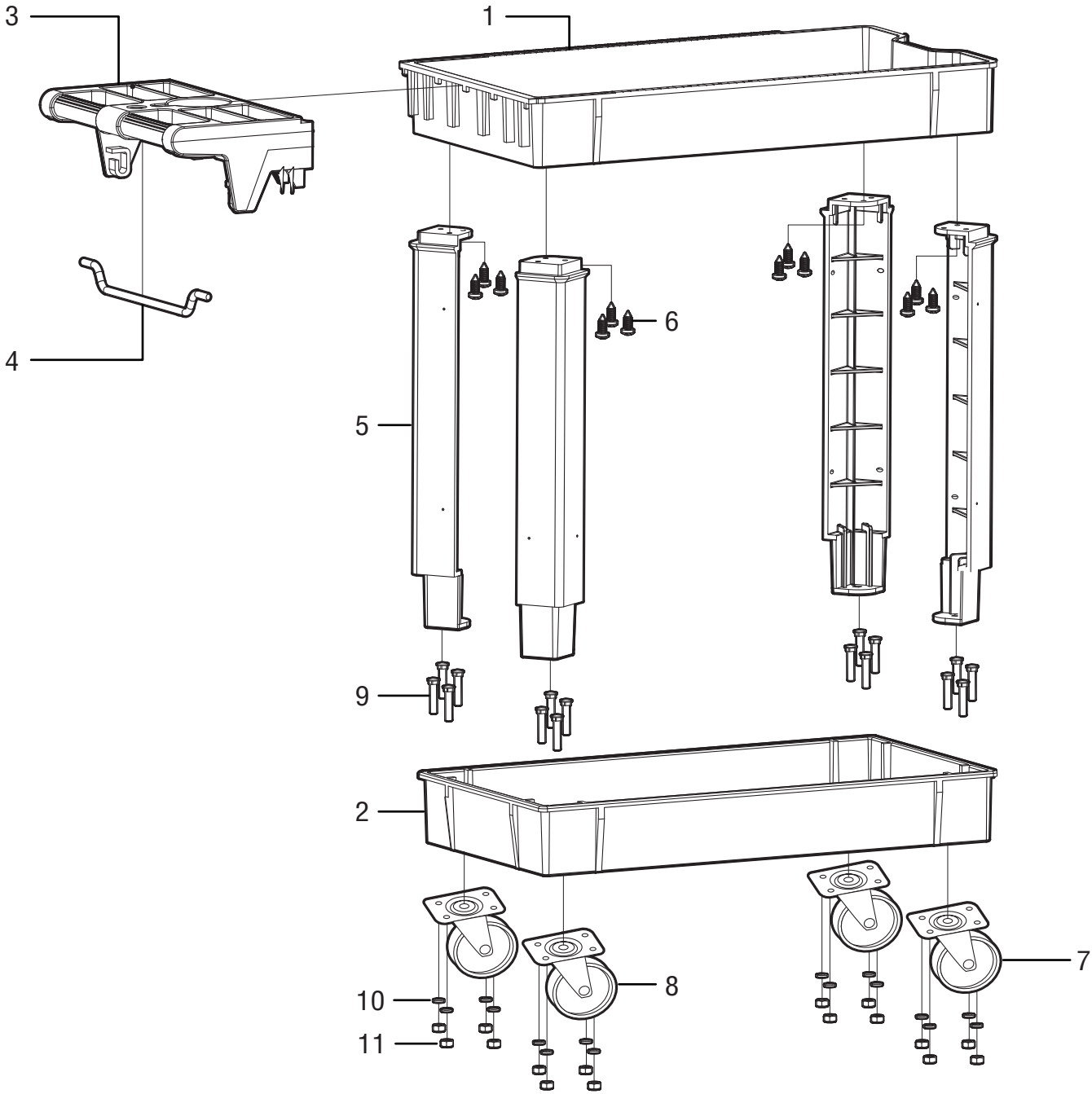

Fig. 6

EXPLODED VIEW & PARTS LIST



NO.	PART NO.	DESCRIPTION	QTY.
1	73009-001	Upper Tray	1
2	73009-002	Lower Tray	1
3	73009-003	Handle	1
4	73009-004	Towel Rack	1
5	73009-005	Legs	4
7	73002-007	Swivel Casters	2
8	73002-008	Fixed Casters	2

NO.	PART NO.	DESCRIPTION	QTY.
6	73002-000	Screws	12
9		Carriage Bolts M8	16
10		Washers	16
11		Lock Nuts, M8	16

WARRANTY STATEMENT

WEN Products is committed to building tools that are dependable for years. Our warranties are consistent with this commitment and our dedication to quality.

LIMITED WARRANTY OF WEN PRODUCTS FOR HOME USE

GREAT LAKES TECHNOLOGIES, LLC (“Seller”) warrants to the original purchaser only, that all WEN consumer power tools will be free from defects in material or workmanship during personal use for a period of two (2) years from date of purchase or 500 hours of use; whichever comes first. Ninety days for all WEN products if the tool is used for professional or commercial use. Purchaser has 30 days from the date of purchase to report missing or damaged parts.

SELLER’S SOLE OBLIGATION AND YOUR EXCLUSIVE REMEDY under this Limited Warranty and, to the extent permitted by law, any warranty or condition implied by law, shall be the replacement of parts, without charge, which are defective in material or workmanship and which have not been subjected to misuse, alteration, careless handling, misrepair, abuse, neglect, normal wear and tear, improper maintenance, or other conditions adversely affecting the Product or the component of the Product, whether by accident or intentionally, by persons other than Seller. To make a claim under this Limited Warranty, you must make sure to keep a copy of your proof of purchase that clearly defines the Date of Purchase (month and year) and the Place of Purchase. Place of Purchase must be a direct vendor of Great Lakes Technologies, LLC. Purchasing through third party vendors, including but not limited to garage sales, pawn shops, resale shops, or any other secondhand merchant, voids the warranty included with this product. Contact techsupport@wenproducts.com or 1-800-232-1195 with the following information to make arrangements: your shipping address, phone number, serial number, required part numbers, and proof of purchase. Damaged or defective parts and products may need to be sent to WEN before the replacements can be shipped out.

Upon the confirmation of a WEN representative, your product may qualify for repairs and service work. When returning a product for warranty service, the shipping charges must be prepaid by the purchaser. The product must be shipped in its original container (or an equivalent), properly packed to withstand the hazards of shipment. The product must be fully insured with a copy of the proof of purchase enclosed. There must also be a description of the problem in order to help our repairs department diagnose and fix the issue. Repairs will be made and the product will be returned and shipped back to the purchaser at no charge for addresses within the contiguous United States.

THIS LIMITED WARRANTY DOES NOT APPLY TO ITEMS THAT WEAR OUT FROM REGULAR USAGE OVER TIME, INCLUDING BELTS, BRUSHES, BLADES, BATTERIES, ETC. ANY IMPLIED WARRANTIES SHALL BE LIMITED IN DURATION TO TWO (2) YEARS FROM DATE OF PURCHASE. SOME STATES IN THE U.S. AND SOME CANADIAN PROVINCES DO NOT ALLOW LIMITATIONS ON HOW LONG AN IMPLIED WARRANTY LASTS, SO THE ABOVE LIMITATION MAY NOT APPLY TO YOU.

IN NO EVENT SHALL SELLER BE LIABLE FOR ANY INCIDENTAL OR CONSEQUENTIAL DAMAGES (INCLUDING BUT NOT LIMITED TO LIABILITY FOR LOSS OF PROFITS) ARISING FROM THE SALE OR USE OF THIS PRODUCT. SOME STATES IN THE U.S. AND SOME CANADIAN PROVINCES DO NOT ALLOW THE EXCLUSION OR LIMITATION OF INCIDENTAL OR CONSEQUENTIAL DAMAGES, SO THE ABOVE LIMITATION OR EXCLUSION MAY NOT APPLY TO YOU.

THIS LIMITED WARRANTY GIVES YOU SPECIFIC LEGAL RIGHTS, AND YOU MAY ALSO HAVE OTHER RIGHTS WHICH VARY FROM STATE TO STATE IN THE U.S., PROVINCE TO PROVINCE IN CANADA AND FROM COUNTRY TO COUNTRY.

THIS LIMITED WARRANTY APPLIES ONLY TO ITEMS SOLD WITHIN THE UNITED STATES OF AMERICA, CANADA AND THE COMMONWEALTH OF PUERTO RICO. FOR WARRANTY COVERAGE WITHIN OTHER COUNTRIES, CONTACT THE WEN CUSTOMER SUPPORT LINE. FOR WARRANTY PARTS OR PRODUCTS REPAIRED UNDER WARRANTY SHIPPING TO ADDRESSES OUTSIDE OF THE CONTIGUOUS UNITED STATES, ADDITIONAL SHIPPING CHARGES MAY APPLY.

**THANKS FOR
REMEMBERING**

