

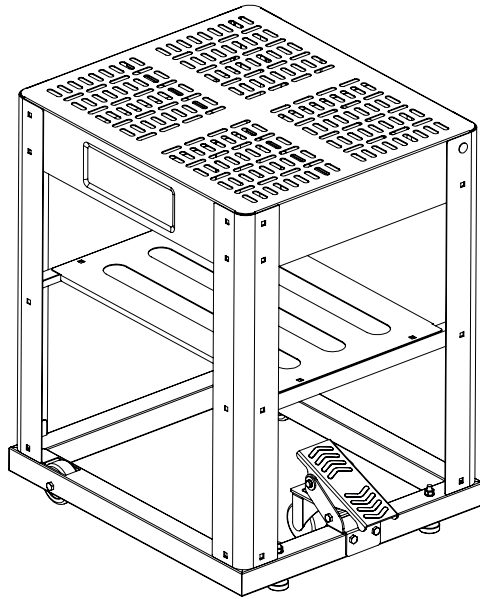

MULTI-PURPOSE PLANER STAND



For replacement
parts visit
WENPRODUCTS.COM

Model # 6588, 6588T
bit.ly/wenvideo

IMPORTANT:

Your new tool has been engineered and manufactured to WEN's highest standards for dependability, ease of operation, and operator safety. When properly cared for, this product will supply you years of rugged, trouble-free performance. Pay close attention to the rules for safe operation, warnings, and cautions. If you use your tool properly and for its intended purpose, you will enjoy years of safe, reliable service.



NEED HELP? CONTACT US!

Have product questions? Need technical support?
Please feel free to contact us at:

 **800-232-1195** (M-F 8AM-5PM CST)

 techsupport@wenproducts.com

 WENPRODUCTS.COM

TABLE OF CONTENTS

Product Specifications	2
Introduction	3
General Safety Rules	4
Specific Rules for the Planer Stand	4
Know Your Planer Stand	5
Assembly	6
Operation.....	8
Exploded View and Parts List	9
Warranty	11

PRODUCT SPECIFICATIONS

Model Number:	6588, 6588T
Stand Height:	29.3 in.
Tabletop Capacity:	220 lbs
Tabletop Dimensions:	23.8 x 20.8 in.
Shelf Capacity:	55 lbs
Shelf Dimensions:	23.7 x 14.5 in.
Weight:	50.7 lbs

INTRODUCTION

Thanks for purchasing a WEN Planer Stand. We know you are excited to mount your favorite planer onto the stand and roll it around your workshop, but first, please take a moment to read through this manual. It contains important information regarding the safe operation and assembly of this product. Please keep this manual available to all users during the entire life of the planer stand.



This manual contains special messages to bring attention to potential safety concerns, as well as helpful assembly and operating information. Please read all the information carefully to avoid injury and machine damage.

QUESTIONS? PROBLEMS?

In order to answer questions and solve problems in the most efficient and speedy manner, please contact our Customer Service at (800) 232-1195, M-F 8-5 CST.

Read and observe all warnings, cautions, and instructions in this manual before the assembly and operation of this planer stand. Failure to follow instructions and safety information could result in serious injury.

NOTE: The following safety information is not meant to cover all possible conditions and situations that may occur. WEN reserves the right to change this product and specifications at any time without prior notice.

GENERAL SAFETY RULES

Safety is a combination of common sense, staying alert and knowing how your item works.

SAVE THESE SAFETY INSTRUCTIONS.



WARNING! Read all safety warnings and all instructions. Failure to follow the warnings and instructions may result in electric shock, fire and serious injury. To avoid mistakes and serious injury, do not plug in your tool until the following steps have been read and understood. Safety instructions can't account for all possibilities, so use your best judgment when using this tool to best prevent injury.

WORK AREA SAFETY

1. Keep work area clean and well lit. Cluttered or dark areas invite accidents. Do not work on floor surfaces that are slippery with sawdust or wax.
2. Do not operate power tools in explosive atmospheres, such as in the presence of flammable liquids, gases or dust. Power tools create sparks which may ignite the dust or fumes.
3. Keep bystanders at a safe distance from the work area. Never allow children or pets near the tool.

PERSONAL SAFETY

1. Stay alert. Watch what you are doing and use common sense when operating a power tool. Do not use a power tool while you are tired or under the influence of drugs, alcohol or medication. A moment of inattention while operating power tools may result in serious personal injury.
2. Use personal protective equipment. Always wear safety goggles at all times that comply with ANSI Z87.1. Use ear protection such as plugs or muffs during extended periods of operation. Wear work gloves to protect your hands. Wear a face mask or dust mask to fight the dust.
3. Do not wear loose clothing, gloves, neckties, or jewelry (rings, watches, etc.) when operating the tool. Inappropriate clothing and items can get caught in moving parts and draw you in. Always wear non-slip footwear and tie back long hair.

SPECIFIC RULES FOR THE PLANER STAND

1. Place the planer stand on a flat and level surface to prevent rocking or tipping.
2. Do not climb, sit or stand on the stand.
3. Follow the assembly instructions carefully when installing the stand.
4. This product is designed to be used as a stand for bench type power tools. Any misuse or abuse of the stand can result in product damage or personal injury. The tabletop will support weight up to 220 pounds and the shelf will support weight up to 55 pounds. Do not exceed the capacity of the stand.
4. The height of the power tool mounted to the stand should not exceed the width of the tool in order to prevent the stand from tipping over. The power tool must be centered and properly secured to the planer stand. Always check to make sure the stand and the power tool are stable before operation.
6. Before attempting to use any tool on the stand, make sure the stand is resting firmly on the floor in locked position with the wheel raised.
7. Keep proper footing and balance at all times. Do not overreach when operating the power tool.

KNOW YOUR PLANER STAND

Make sure all the following parts are accounted for before discarding the packaging.
If any part is missing or broken, contact our customer service at 1-800-232-1195.

1

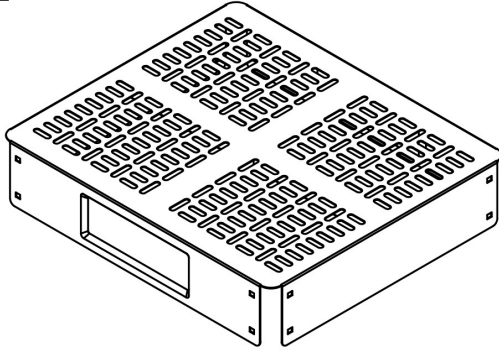

2

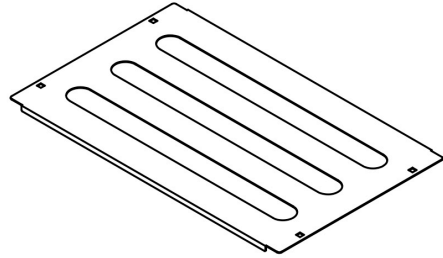

3

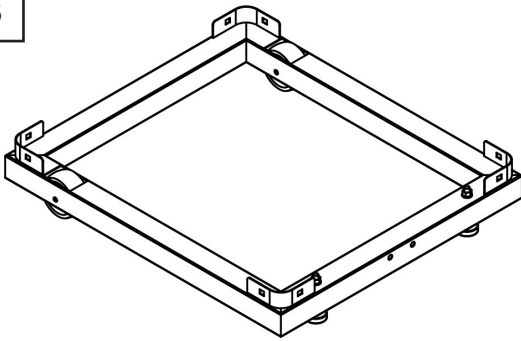

4

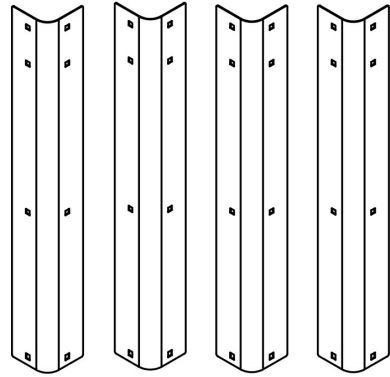

5

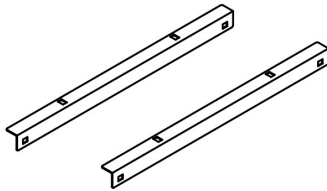

6

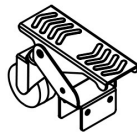

7



8



11



9



10



COMPONENTS

1. Tabletop	x1	8. M8-1.25X60 Bolt	x2
2. Shelf	x1	9. M8 Washer	x34
3. Base Assembly	x1	10. M8-1.25 Hex Nut	x34
4. Leg	x4	11. (For mounting power tool to the stand)	
5. Shelf Bracket	x2	M8-1.25X60 Bolt	x4
6. Pedal Assembly	x1	M8 Washer	x4
7. Carriage Bolt	x32	M8-1.25 Hex Nut	x4

ASSEMBLY

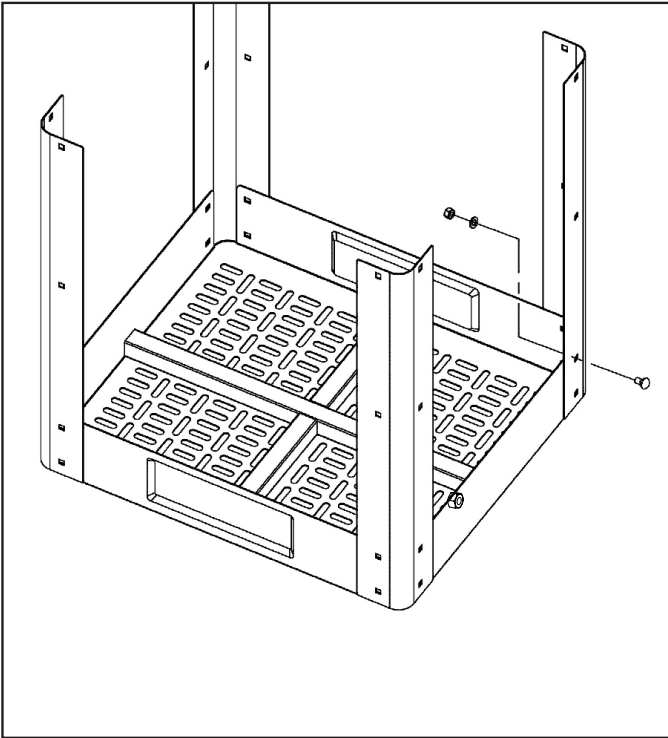

STEP 1: INSTALL THE LEGS ONTO THE TABLE TOP

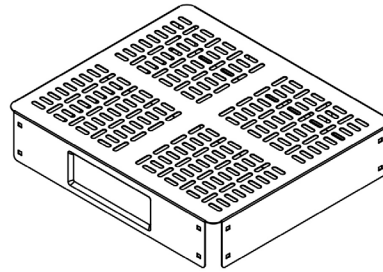

1. Place the table top on the floor, install one leg to a corner of the table top using four carriage bolts, M8 washers and M8-1.25 hex nuts. Repeat with all four legs. Finger tighten the bolts to leave room for adjustments when attaching the base.



Tabletop x 1

-  Carriage Bolts x 16
-  M8 Washers x 16
-  M8-1.25 Hex Nuts x 16

STEP 2: INSTALL THE BASE

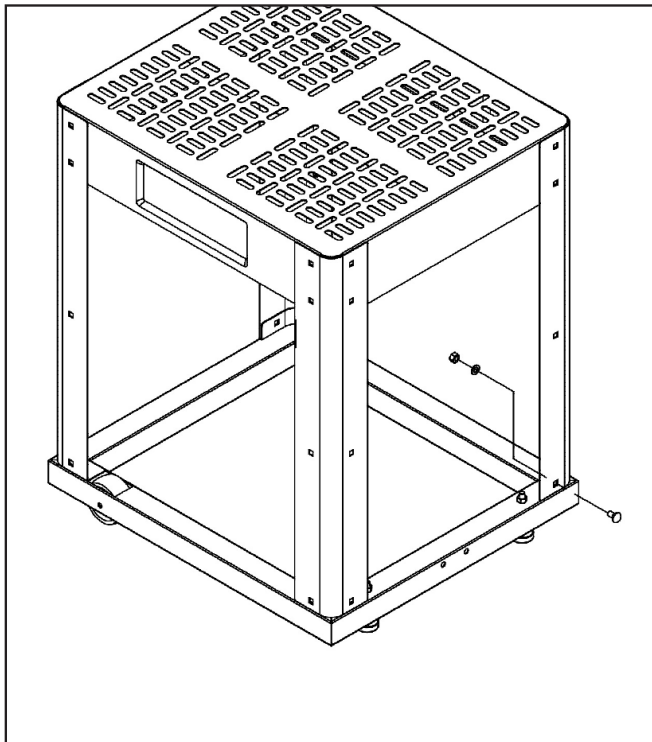

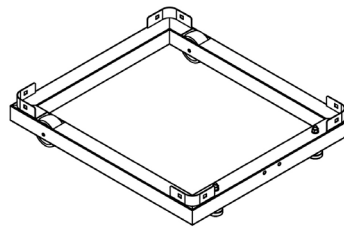

2. Attach the table top and leg assembly to the base. Secure each of the four corners with four carriage bolts, M8 washers and M8-1.25 hex nuts. After setting the position, fully tighten all 24 bolts connecting the legs with the tabletop and the base assembly.

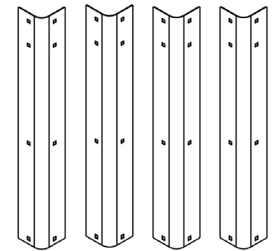

Base Assembly x 1



Legs x 4

-  Carriage Bolts x 8
-  M8 Washers x 8
-  M8-1.25 Hex Nuts x 8

ASSEMBLY

STEP 3: INSTALL THE PEDAL ASSEMBLY

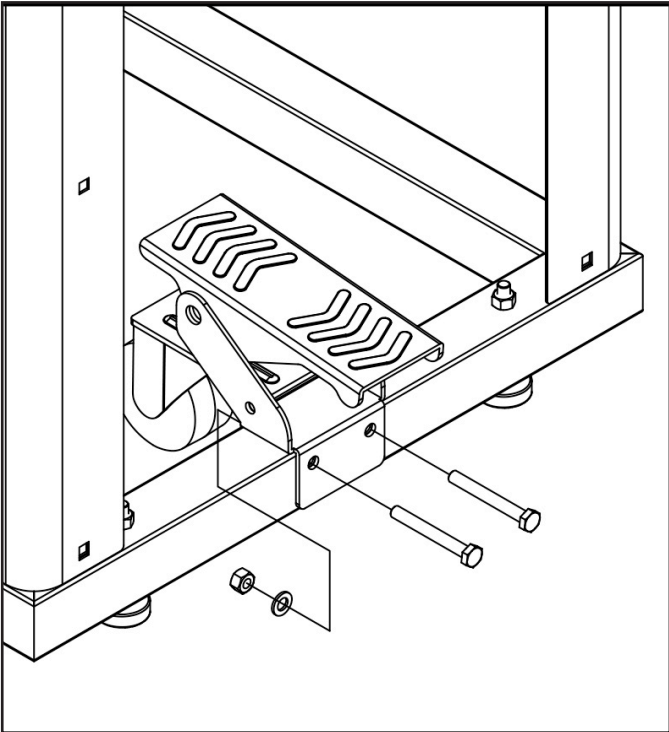

3. Attach the pedal assembly to the base using two M8-1.25X60 hex bolts, M8 washers and M8-1.25 hex nuts. The wheel should be positioned inside the base assembly.

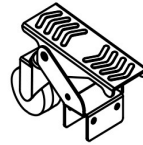

Pedal Assembly x 1



M8-1.25X60 Bolts x 2



M8 Washers x 2



M8-1.25 Hex Nuts x 2

STEP 4: INSTALL THE SHELF

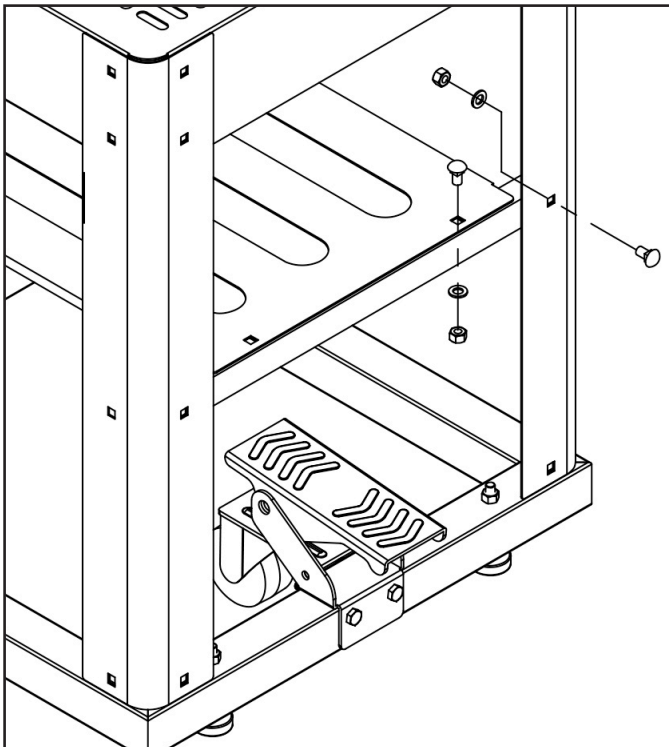

4. Attach the two support brackets onto the legs with four carriage bolts, M8 washers and M8-1.25 hex nuts. Install the shelf onto the support brackets using four carriage bolts, M8 washers and M8-1.25 hex nuts.

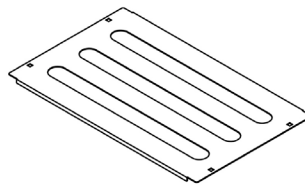

Shelf x 1

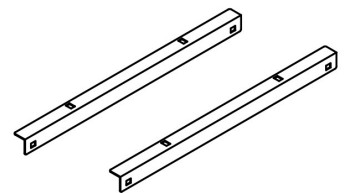

Shelf Brackets x 2



Carriage Bolts x 8



M8 Washers x 8



M8-1.25 Hex Nuts x 8

ASSEMBLY

STEP 5: ATTACH THE POWER TOOL

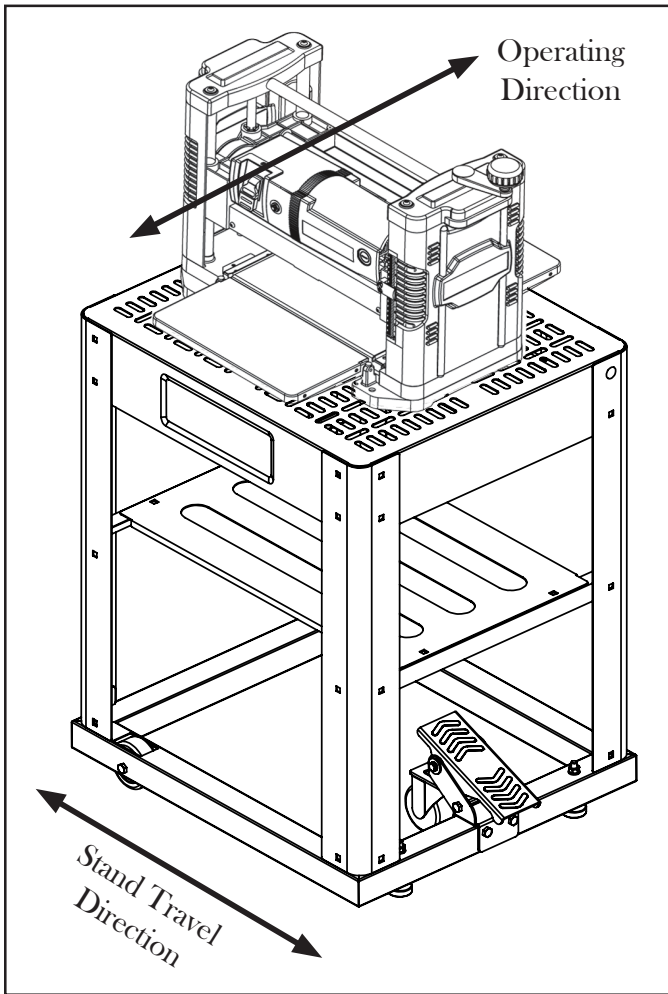

5. Now is the moment you've been waiting for. Unplug and bring over your favorite power tool. Make sure the weight does not exceed the stand capacity and the tool is wider than it is tall. Place the power tool on the center of the tabletop to maximize stability. Orient it so you will be operating the tool on the side perpendicular to the direction of the stand's travel.

Mount the power tool onto the stand using four M8-1.25X60 bolts, M8 washers and M8-1.25 hex nuts. Check to make sure the tool is securely mounted and the stand is stable.

WARNING: Only mount the planer so boards are fed perpendicular to the direction of the wheels' rotation. Never mount the planer so boards are fed in the same direction that the stand travels.



M8-1.25X60 Bolts x4



M8 Washers x 4



M8-1.25 Hex Nuts x 4

OPERATION

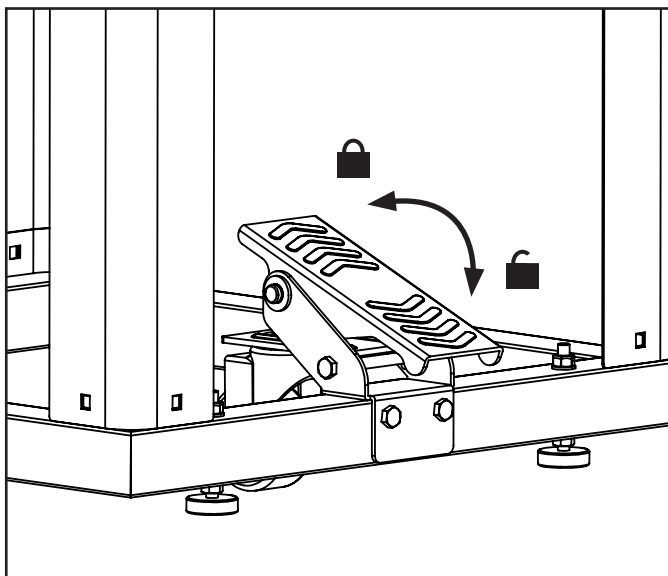

TO MOVE THE STAND:

Hold the tabletop and step down on the foot pedal to unlock and engage the wheel. Carefully move the stand to a new location. **CAUTION:** Tipping can occur if wheels are stopped abruptly by debris on the floor.

TO SET DOWN THE STAND:

Hold the tabletop and push the foot pedal up to raise the wheel. Support the weight as the stand drops into the locked position.

WARNING: Do not operate any power tool that is mounted to the planer stand when the wheel is engaged. Always make sure the wheel is in the raised position and the stand is stable before operation.

EXPLODED VIEW AND PARTS LIST

No	Part Number	Description	Qty
1	6588-001	Tabletop	1
2	6588-002	Leg	4
3	6588-003	Shelf	1
4	6588-004	Shelf Bracket	2
5	6588-005	Base Assembly	1
6	6588-006	Pivot Wheel Bracket	1
7	6588-007	Foot Pedal	1
8	6588-008	Shaft	1
9	6588-009	Spacer	2
10	6588-010	Foot	2
11	6588-011	Pedal Shaft	1
12	6588-012	M12 Washer	4
13	6588-013	Pivot Wheel	1
14	6588-014	Retaining Ring	2
15	6588-015	M8-1.25X100 Bolt	1
16	6588-016	M8-1.25 Lock Nut	3
17	6588-017	M8-1.25 Hex Nut	42
18	6588-018	M8 Washer	40
19	6588-019	M8-1.25X60 Bolt	8
20	6588-020	Retaining Ring	2
21	6588-021	Wheel	2
22	6588-022	Carriage Bolt	32
23	6588-023	Pedal Subassembly	1

EXPLODED VIEW AND PARTS LIST

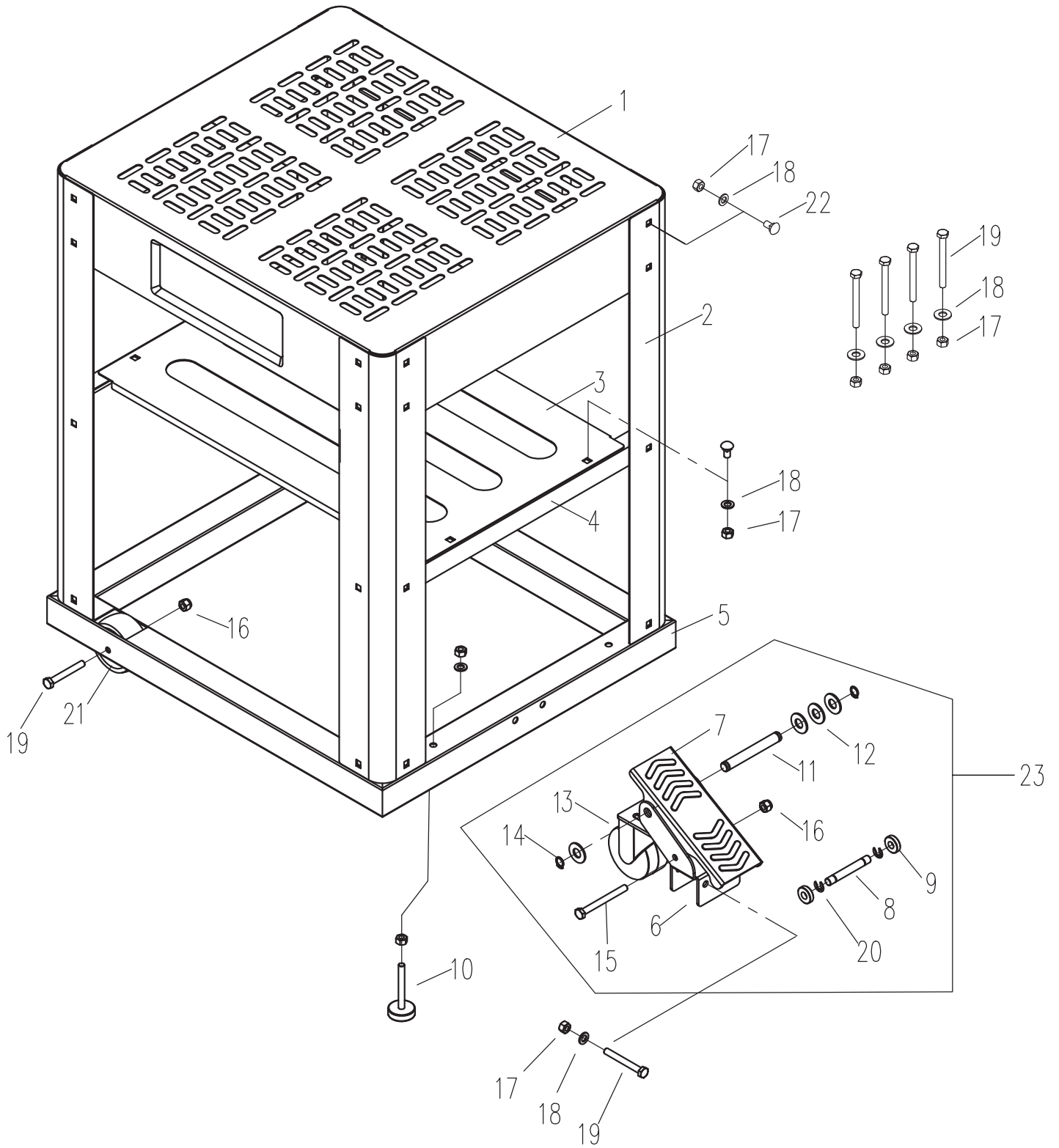

LIMITED TWO YEAR WARRANTY

WEN Products is committed to building tools that are dependable for years. Our warranties are consistent with this commitment and our dedication to quality.

LIMITED WARRANTY OF WEN CONSUMER POWER TOOLS PRODUCTS FOR HOME USE

GREAT LAKES TECHNOLOGIES, LLC (“Seller”) warrants to the original purchaser only, that all WEN consumer power tools will be free from defects in material or workmanship for a period of two (2) years from date of purchase. Ninety days for all WEN products, if the tool is used for professional use.

SELLER’S SOLE OBLIGATION AND YOUR EXCLUSIVE REMEDY under this Limited Warranty and, to the extent permitted by law, any warranty or condition implied by law, shall be the repair or replacement of parts, without charge, which are defective in material or workmanship and which have not been misused, carelessly handled, or misrepaired by persons other than Seller or Authorized Service Center. To make a claim under this Limited Warranty, you must make sure to keep a copy of your proof of purchase that clearly defines the Date of Purchase (month and year) and the Place of Purchase. Place of purchase must be a direct vendor of Great Lakes Technologies, LLC. Third party vendors such as garage sales, pawn shops, resale shops, or any other secondhand merchant void the warranty included with this product. Contact techsupport@wenproducts.com or 1-800-232-1195 to make arrangements for repairs and transportation.

When returning a product for warranty service, the shipping charges must be prepaid by the purchaser. The product must be shipped in its original container (or an equivalent), properly packed to withstand the hazards of shipment. The product must be fully insured with a copy of the warranty card and/or the proof of purchase enclosed. There must also be a description of the problem in order to help our repairs department diagnose and fix the issue. Repairs will be made and the product will be returned and shipped back to the purchaser at no charge.

THIS LIMITED WARRANTY DOES NOT APPLY TO ACCESSORY ITEMS THAT WEAR OUT FROM REGULAR USAGE OVER TIME INCLUDING BELTS, BRUSHES, BLADES, ETC.

ANY IMPLIED WARRANTIES SHALL BE LIMITED IN DURATION TO TWO (2) YEARS FROM DATE OF PURCHASE. SOME STATES IN THE U.S., SOME CANADIAN PROVINCES DO NOT ALLOW LIMITATIONS ON HOW LONG AN IMPLIED WARRANTY LASTS, SO THE ABOVE LIMITATION MAY NOT APPLY TO YOU.

IN NO EVENT SHALL SELLER BE LIABLE FOR ANY INCIDENTAL OR CONSEQUENTIAL DAMAGES (INCLUDING BUT NOT LIMITED TO LIABILITY FOR LOSS OF PROFITS) ARISING FROM THE SALE OR USE OF THIS PRODUCT. SOME STATES IN THE U.S. AND SOME CANADIAN PROVINCES DO NOT ALLOW THE EXCLUSION OR LIMITATION OF INCIDENTAL OR CONSEQUENTIAL DAMAGES, SO THE ABOVE LIMITATION OR EXCLUSION MAY NOT APPLY TO YOU.

THIS LIMITED WARRANTY GIVES YOU SPECIFIC LEGAL RIGHTS, AND YOU MAY ALSO HAVE OTHER RIGHTS WHICH VARY FROM STATE TO STATE IN THE U.S., PROVINCE TO PROVINCE IN CANADA AND FROM COUNTRY TO COUNTRY.

THIS LIMITED WARRANTY APPLIES ONLY TO PORTABLE ELECTRIC TOOLS, BENCH POWER TOOLS, OUTDOOR POWER EQUIPMENT AND PNEUMATIC TOOLS SOLD WITHIN THE UNITED STATES OF AMERICA, CANADA AND THE COMMONWEALTH OF PUERTO RICO. FOR WARRANTY COVERAGE WITHIN OTHER COUNTRIES, CONTACT THE WEN CUSTOMER SUPPORT LINE.

THANKS FOR REMEMBERING

