

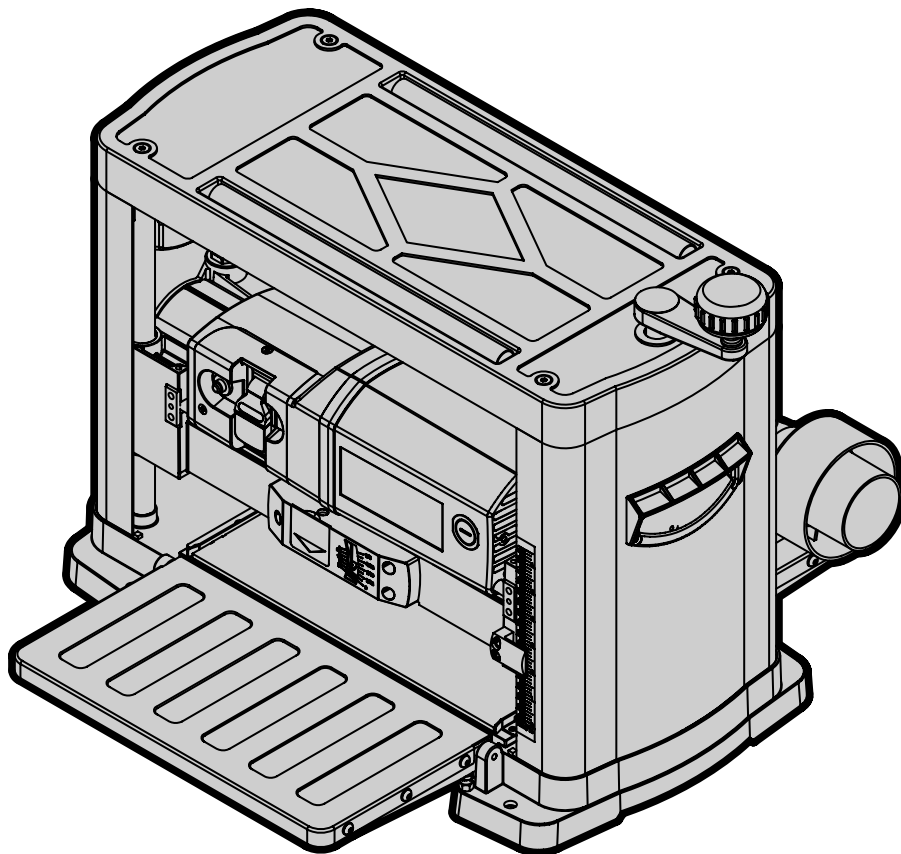

13-INCH THICKNESS PLANER

Instruction Manual



NEED HELP? CONTACT US!

Have product questions? Need technical support? Please feel free to contact us:



1-800-232-1195 (M-F 8AM-5PM CST)



TECHSUPPORT@WENPRODUCTS.COM

IMPORTANT: Your new tool has been engineered and manufactured to WEN's highest standards for dependability, ease of operation, and operator safety. When properly cared for, this product will supply you years of rugged, trouble-free performance. Pay close attention to the rules for safe operation, warnings, and cautions. If you use your tool properly and for its intended purpose, you will enjoy years of safe, reliable service.

For replacement parts and the most up-to-date instruction manuals, visit ***WENPRODUCTS.COM***

CONTENTS

WELCOME	3
Introduction	3
Specifications.....	3
SAFETY	4
General Safety Rules	4
Planer Safety Warnings.....	6
Electrical Information.....	7
BEFORE OPERATING	8
Unpacking & Packing List	8
Know Your Planer	9
Assembly & Adjustments.....	10
OPERATION & MAINTENANCE	11
Operation	11
Maintenance.....	15
Troubleshooting Guide.....	17
Exploded View & Parts List.....	18
Warranty Statement	20

To purchase accessories for your tool, visit ***WENPRODUCTS.COM***

Multi-Purpose Planer Stand (Model No. 6588T)

Planer Miter Saw Stand (Model No. MSA658)

Replacement Thickness Planer Blades (Model No. 6552-043)

INTRODUCTION

Thanks for purchasing the WEN Thickness Planer. We know you are excited to put your tool to work, but first, please take a moment to read through the manual. Safe operation of this tool requires that you read and understand this operator's manual and all the labels affixed to the tool. This manual provides information regarding potential safety concerns, as well as helpful assembly and operating instructions for your tool.

 Indicates danger, warning, or caution. The safety symbols and the explanations with them deserve your careful attention and understanding. Always follow the safety precautions to reduce the risk of fire, electric shock or personal injury. However, please note that these instructions and warnings are not substitutes for proper accident prevention measures.

NOTE: The following safety information is not meant to cover all possible conditions and situations that may occur. WEN reserves the right to change this product and specifications at any time without prior notice.

At WEN, we are continuously improving our products. If you find that your tool does not exactly match this manual, please visit wenproducts.com for the most up-to-date manual or contact our customer service at **1-800-232-1195**.

Keep this manual available to all users during the entire life of the tool and review it frequently to maximize safety for both yourself and others.

SPECIFICATIONS

Model Number	6552, 6552T
Motor	120V, 60 Hz, 15A
Number of Blades	3 Blades
Cutterhead Speed	8,500 RPM
Cuts Per Minute	25,500
Feed Rate	26 FPM
Max Depth of Cut	3/32 in. (for workpieces under 6 in. wide)
	1/32 in. (for workpieces over 6 in. wide)
Table Size	13-1/4 in. x 9-1/2 in.
Extension Table Size	13-1/4 in. x 7-1/2 in.
Base Size	21-3/4 in. x 12-1/2 in.
Max Workpiece Width	13 in.
Max Workpiece Thickness	6 in.
Dust Chute Port Size	2 in., 2-1/2 in., and 4 in.
Weight	66 lbs.

GENERAL SAFETY RULES

 **WARNING!** Read all safety warnings and all instructions. Failure to follow the warnings and instructions may result in electric shock, fire and/or serious injury.

Safety is a combination of common sense, staying alert and knowing how your item works. The term “power tool” in the warnings refers to your mains-operated (corded) power tool or battery-operated (cordless) power tool.

SAVE THESE SAFETY INSTRUCTIONS.

WORK AREA SAFETY

- 1. Keep work area clean and well lit.** Cluttered or dark areas invite accidents.
- 2. Do not operate power tools in explosive atmospheres, such as in the presence of flammable liquids, gases or dust.** Power tools create sparks which may ignite the dust or fumes.
- 3. Keep children and bystanders away while operating a power tool.** Distractions can cause you to lose control.

ELECTRICAL SAFETY

- 1. Power tool plugs must match the outlet. Never modify the plug in any way. Do not use any adapter plugs with earthed (grounded) power tools.** Unmodified plugs and matching outlets will reduce risk of electric shock.
- 2. Avoid body contact with earthed or grounded surfaces such as pipes, radiators, ranges and refrigerators.** There is an increased risk of electric shock if your body is earthed or grounded.
- 3. Do not expose power tools to rain or wet conditions.** Water entering a power tool will increase the risk of electric shock.
- 4. Do not abuse the cord. Never use the cord for carrying, pulling or unplugging the power tool. Keep cord away from heat, oil, sharp edges or moving parts.** Damaged or entangled cords increase the risk of electric shock.
- 5. When operating a power tool outdoors, use an extension cord suitable for outdoor use.** Use of a cord suitable for outdoor use reduces the risk of electric shock.

- 6. If operating a power tool in a damp location is unavoidable, use a ground fault circuit interrupter (GFCI) protected supply.** Use of a GFCI reduces the risk of electric shock.

PERSONAL SAFETY

- 1. Stay alert, watch what you are doing and use common sense when operating a power tool. Do not use a power tool while you are tired or under the influence of drugs, alcohol or medication.** A moment of inattention while operating power tools may result in serious personal injury.
- 2. Use personal protective equipment. Always wear eye protection.** Protective equipment such as a respiratory mask, non-skid safety shoes and hearing protection used for appropriate conditions will reduce the risk of personal injury.
- 3. Prevent unintentional starting. Ensure the switch is in the off-position before connecting to power source and/or battery pack, picking up or carrying the tool.** Carrying power tools with your finger on the switch or energizing power tools that have the switch on invites accidents.
- 4. Remove any adjusting key or wrench before turning the power tool on.** A wrench or a key left attached to a rotating part of the power tool may result in personal injury.
- 5. Do not overreach. Keep proper footing and balance at all times.** This enables better control of the power tool in unexpected situations.
- 6. Dress properly. Do not wear loose clothing or jewelry. Keep your hair and clothing away from moving parts.** Loose clothes, jewelry or long hair can be caught in moving parts.

GENERAL SAFETY RULES

 **WARNING!** Read all safety warnings and all instructions. Failure to follow the warnings and instructions may result in electric shock, fire and/or serious injury.

Safety is a combination of common sense, staying alert and knowing how your item works. The term “power tool” in the warnings refers to your mains-operated (corded) power tool or battery-operated (cordless) power tool.

SAVE THESE SAFETY INSTRUCTIONS.

7. If devices are provided for the connection of dust extraction and collection facilities, ensure these are connected and properly used. Use of dust collection can reduce dust-related hazards.

POWER TOOL USE AND CARE

1. Do not force the power tool. Use the correct power tool for your application. The correct power tool will do the job better and safer at the rate for which it was designed.

2. Do not use the power tool if the switch does not turn it on and off. Any power tool that cannot be controlled with the switch is dangerous and must be repaired.

3. Disconnect the plug from the power source and/or the battery pack from the power tool before making any adjustments, changing accessories, or storing power tools. Such preventive safety measures reduce the risk of starting the power tool accidentally.

4. Store idle power tools out of the reach of children and do not allow persons unfamiliar with the power tool or these instructions to operate the power tool. Power tools are dangerous in the hands of untrained users.

5. Maintain power tools. Check for misalignment or binding of moving parts, breakage of parts and any other condition that may affect the power tool's operation. If damaged, have the power tool repaired before use. Many accidents are caused by poorly maintained power tools.

6. Keep cutting tools sharp and clean. Properly maintained cutting tools with sharp cutting edges are less likely to bind and are easier to control.

7. Use the power tool, accessories and tool bits, etc. in accordance with these instructions, taking into account the working conditions and the work to be performed. Use of the power tool for operations different from those intended could result in a hazardous situation.

8. Use clamps to secure your workpiece to a stable surface. Holding a workpiece by hand or using your body to support it may lead to loss of control.

9. KEEP GUARDS IN PLACE and in working order.

SERVICE

1. Have your power tool serviced by a qualified repair person using only identical replacement parts. This will ensure that the safety of the power tool is maintained.

CALIFORNIA PROPOSITION 65 WARNING

Some dust created by power sanding, sawing, grinding, drilling, and other construction activities may contain chemicals, including lead, known to the State of California to cause cancer, birth defects, or other reproductive harm. Wash hands after handling. Some examples of these chemicals are:

- Lead from lead-based paints.
- Crystalline silica from bricks, cement, and other masonry products.
- Arsenic and chromium from chemically treated lumber.

Your risk from these exposures varies depending on how often you do this type of work. To reduce your exposure to these chemicals, work in a well-ventilated area with approved safety equipment such as dust masks specially designed to filter out microscopic particles.

PLANER SAFETY WARNINGS

 **WARNING!** Do not let comfort or familiarity with the product replace strict adherence to product safety rules. Failure to follow the safety instructions may result in serious personal injury.

PLANER SAFETY

1. Whenever adjusting or replacing any parts on planer, turn switch OFF and remove plug from power source.
2. Make sure all guards are properly attached and securely fastened.
3. Make sure all moving parts are free from interference.
4. Always wear eye protection or face shield.
5. Make sure blades are properly aligned and properly attached to cutterhead.
6. Do not plug in planer unless the switch is in the off position. After turning the switch on, allow the planer to come to full speed before operating.
7. Keep hands clear of all moving parts.
8. Do not force cut. Slowing or stalling will overheat motor. Allow automatic feed to function properly.
9. Use quality lumber. Blades last longer and cuts are smoother with good quality wood.
10. Do not plane material shorter than 15", narrower than 3/4", wider than 12-1/2" or thinner than 1/2".
11. Never make a planing cut deeper than 3/32".
12. For workpieces longer than 24", use material support stands.
13. Always feed from infeed side to outfeed side, and do not attempt to reverse direction of workpiece being planed while it is being fed through the planer.
14. Take precautions against kickback. Do not permit anyone to stand or cross in line of cutterhead's rotation. Kickback or thrown debris will travel in this direction.
15. Turn switch off and disconnect power whenever planer is not in use.
16. Replace knives if damaged or dull.
17. Keep planer maintained. Follow maintenance instructions.
18. Don't plane against the grain of the wood. (Refer to Operation Section, Page 14)

These safety instructions can't possibly warn of every scenario that may arise with this tool, always make sure to stay alert and use common sense during operation.

ELECTRICAL INFORMATION

GROUNDING INSTRUCTIONS

In the event of a malfunction or breakdown, grounding provides the path of least resistance for an electric current and reduces the risk of electric shock. This tool is equipped with an electric cord that has an equipment grounding conductor and a grounding plug. The plug **MUST** be plugged into a matching outlet that is properly installed and grounded in accordance with ALL local codes and ordinances.

1. Do not modify the plug provided. If it will not fit the outlet, have the proper outlet installed by a licensed electrician.

2. Improper connection of the equipment grounding conductor can result in electric shock. The conductor with the green insulation (with or without yellow stripes) is the equipment grounding conductor. If repair or replacement of the electric cord or plug is necessary, **DO NOT** connect the equipment grounding conductor to a live terminal.

3. Check with a licensed electrician or service personnel if you do not completely understand the grounding instructions or whether the tool is properly grounded.

4. Use only three-wire extension cords that have three-pronged plugs and outlets that accept the tool's plug. Repair or replace a damaged or worn cord immediately.

CAUTION! In all cases, make certain the outlet in question is properly grounded. If you are not sure, have a licensed electrician check the outlet.

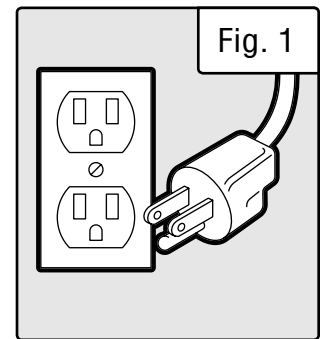

GUIDELINES AND RECOMMENDATIONS FOR EXTENSION CORDS

When using an extension cord, be sure to use one heavy enough to carry the current your product will draw. An undersized cord will cause a drop in line voltage resulting in loss of power and overheating. The table below shows the correct size to be used according to cord length and ampere rating. When in doubt, use a heavier cord. The smaller the gauge number, the heavier the cord.

AMPERAGE	REQUIRED GAUGE FOR EXTENSION CORDS			
	25 ft.	50 ft.	100 ft.	150 ft.
15A	14 gauge	12 gauge	10 gauge	8 gauge

1. Examine extension cord before use. Make sure your extension cord is properly wired and in good condition. Always replace a damaged extension cord or have it repaired by a qualified person before using it.

2. Do not abuse extension cord. Do not pull on cord to disconnect from receptacle; always disconnect by pulling on plug. Disconnect the extension cord from the receptacle before disconnecting the product from the extension cord. Protect your extension cords from sharp objects, excessive heat and damp/wet areas.

3. Use a separate electrical circuit for your tool. This circuit must not be less than a 12-gauge wire and should be protected with a 15A time-delayed fuse. Before connecting the motor to the power line, make sure the switch is in the OFF position and the electric current is rated the same as the current stamped on the motor nameplate. Running at a lower voltage will damage the motor.

UNPACKING & PACKING LIST

UNPACKING

With the help of a friend or trustworthy foe, such as one of your in-laws, carefully remove the planer from the packaging and place it on a sturdy, flat surface. Make sure to take out all contents and accessories. Do not discard the packaging until everything is removed. Check the packing list below to make sure you have all of the parts and accessories. If any part is missing or broken, please contact customer service at **1-800-232-1195** (M-F 8-5 CST), or email techsupport@wenproducts.com.

PACKING LIST

Components

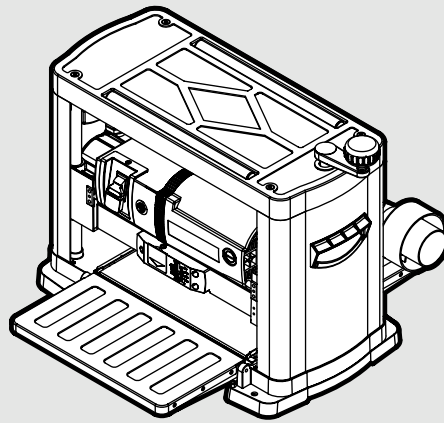

Planer

Accessories

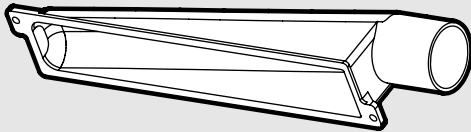

Dust Chute (1)

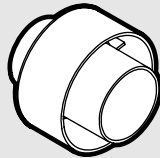

Dust Chute Adapter (1)



Magnets (2)

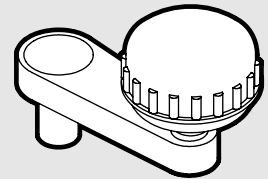

Depth Adjusting Handle (1)



T-handle Hex Wrench (1)



Bolt with Flat Washer (1)



Thumb Screws (2)



Handle Cap (1)

KNOW YOUR PLANER

TOOL PURPOSE

Resurface boards, flatten workpieces, and much more with your WEN Thickness Planer. Refer to the diagram below to become familiarized with the parts and controls of your thickness planer.

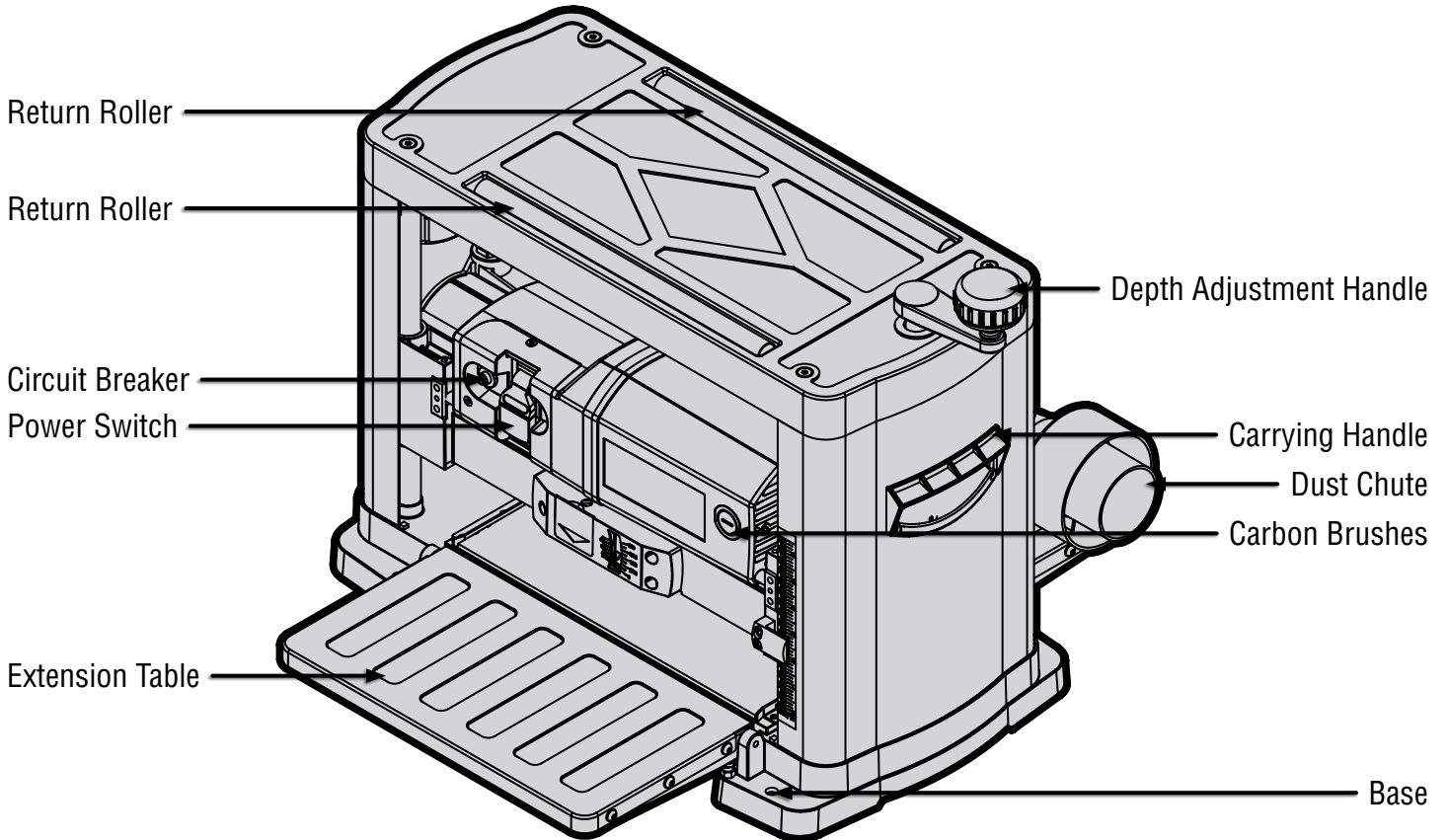

ASSEMBLY & ADJUSTMENTS

ATTACHING THE DEPTH ADJUSTMENT HANDLE

1. Secure the depth adjustment handle (Fig. 2 - 1) to the top of the planer using the included socket head bolt (Fig. 2 - 2) and washer (Fig. 2 - 3).

3. Place the handle cap (Fig. 2 - 4) on top of the depth adjustment handle, covering the socket head bolt and washer.

NOTE: With each full rotation of the depth-adjustment handle, the planer's height adjusts 1/16". For example, 1/4 of a rotation is 1/64", 1/2 of a rotation is 1/32", and 1 full rotation is 1/16".

PREPARING THE TABLES

1. Lower the infeed and outfeed tables (Fig. 3).

Remove the foam insert located between the main table and the blade drum. Peel back the protective film insert from the main table.

ATTACHING THE DUST CHUTE

1. Mount the dust chute (Fig. 4 - 1) to the rollercase using the two thumb screws (Fig. 4 - 2).

NOTE: The dust chute can be mounted in either direction to direct the flow of chips to either side of the planer.

2. After mounting, connect a dust collection system to the dust chute. Use the dust chute adapter if needed. Be sure to turn the system on before operating the planer.

NOTE: If you do not plan on using a dust collection system of any kind, we recommend removing the dust chute so that the wood chips and debris can fly freely from the back of the planer. This will, however, make a mess in your shop. The other option would be to leave it on and then regularly clean the wood shavings and dust out of the planer and chute during operation. **Any damage or other problem caused by a failure to keep the planer clean (by not using dust collection, removing wood chips, etc.) is not covered under the warranty.**

MOUNTING THE PLANER TO A WORK SURFACE

The planer should always be mounted to a stable, level bench or table in a well-lit area. Make sure there is plenty of room for moving the workpiece through the entire cut. Neither the operator nor bystanders should stand in line with the workpiece while the tool is operating.

1. Mount the planer to a workbench or tool stand using four bolts, four flat washers, and four hex nuts (not included) through the mounting holes on the base (Fig. 5).

NOTE: We recommend the WEN 6588T Rolling Planer Stand for both stability and easy transportation around the workshop.

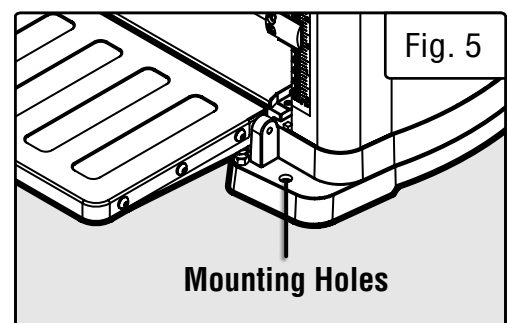
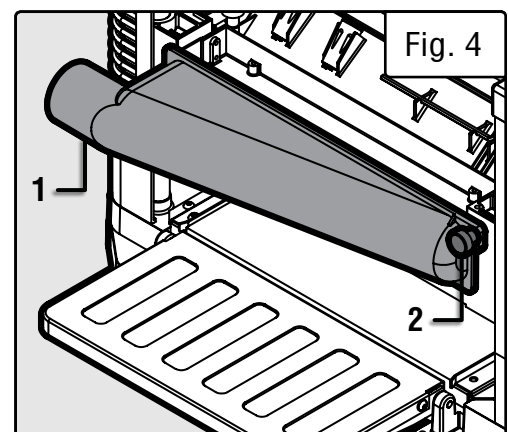
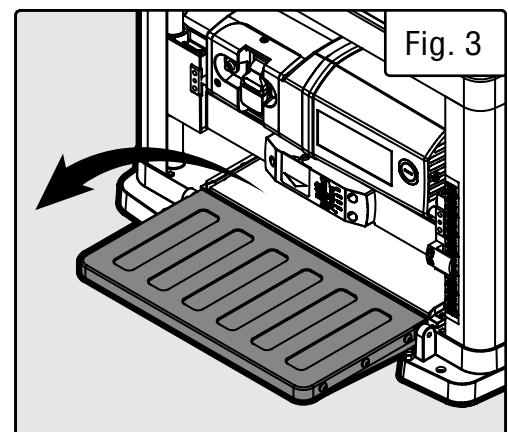
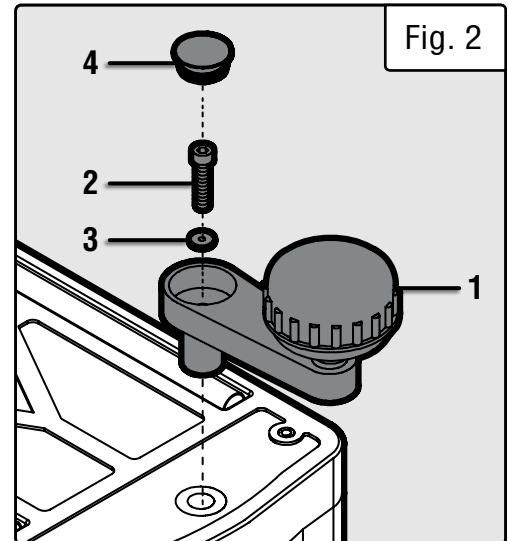

OPERATION

⚠ WARNING! Do not connect planer to the power source until all assembly steps have been completed.

ON / OFF SWITCH

The ON / OFF switch (Fig. 6 - 1) is located on the front of the planer motor. To turn the planer ON, flip the switch to the up position. To turn the planer OFF, flip the switch to the down position.

SWITCH LOCK

Remove the yellow tab to engage child-safety lock and prevent unwanted start-ups. To lock the switch, flip the switch to the OFF position and disconnect the planer from its power source. Pull the yellow portion of the key out (Fig. 6 - 2). The switch cannot be turned on with the key removed. To turn the machine back on, slide the key into the slot on the switch until it snaps into place.

NOTE: The key can be removed from the switch while in the ON position. This allows for the device to be turned off, but prevents it from being turned back on.

CIRCUIT BREAKER

This planer is equipped with a circuit breaker to protect the motor (Fig. 6 - 3). The breaker will automatically shut the planer off when excessive current is drawn. If the breaker is tripped, turn the planer off, wait a moment to allow the breaker to cool down, and reset the circuit by pressing the button. If the button pops back out, wait a few more minutes to allow it to cool down more. Reduce the depth of cut.

CAUTION: Be sure to turn the planer off prior to resetting the circuit breaker to avoid unintentional start-up of the planer.

AVOID DAMAGE TO BLADES

Thickness planers are a precision woodworking machine and should be used on quality lumber only. Do not plane dirty boards; dirt and small stones are abrasive and will wear out blade.

⚠ WARNING! REMOVE NAILS AND STAPLES. Use planer to cut wood only. Avoid knots. Heavily cross-grained wood makes knots hard. Knots can come loose and jam blade.

⚠ WARNING! Any article that encounters planer blades may be forcibly ejected from the planer, creating a risk of injury. Make sure the wood is free from foreign materials before attempting to plane.

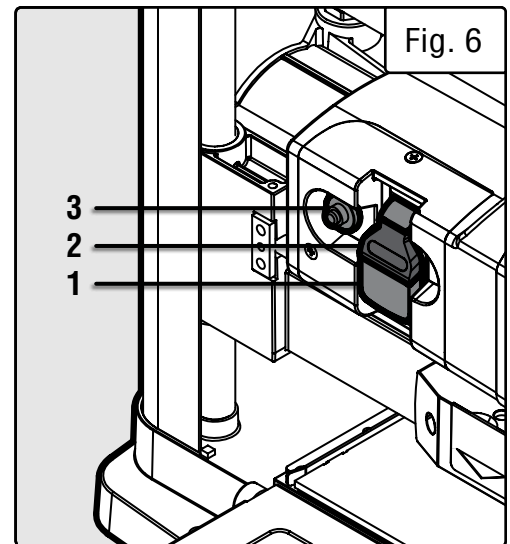

OPERATION

HEIGHT OF CUT

Rotate crank handle (Fig. 7 - 1) to adjust height of cutterhead. The depth scale (Fig. 7 - 2) shows height of the cutterhead above the main table. The quality of the planed wood depends on the operator's experience and judgment about the depth of cut. The depth of cut depends on the width, species, hardness, moisture content, grain direction, and grain structure of the wood. The maximum thickness is $3/32$ " for planing operations.

A spring loaded depth-of-cut gauge (Fig. 7 - 3) is attached to the front of the rollercase. The pointer on the depth-of-cut gauge accurately displays the depth of cut per pass when the workpiece is positioned below the gauge.

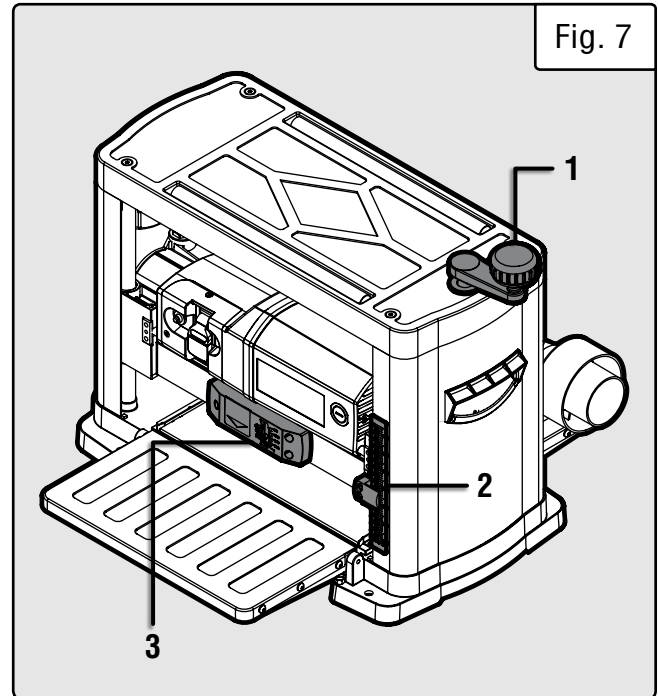

⚠ WARNING! Never plane against the grain direction of the wood. Do not plane end grain, as the wood could splinter or possibly explode.

⚠ WARNING! Do not plane any board shorter than $14\text{-}1/2$ "; the force of the cut could split the board and cause kickback.

DEPTH OF CUT

The front of the rollercase features two small ($1/16$ ") depth-limiting lips on either side of the cutterhead body to establish the maximum cutting depth as $1/32$ " , instead of $3/32$ " , for boards wider than 6" .

While the planer could handle a $3/32$ " cut on 13" wide boards, it will not only shorten the lifespan of the motor and cutting blades, but also will give an imperfect finish. The smaller the cutting depth, the better the finished product will be. It is best to take multiple shallow passes on a workpiece, rather than one deep pass.

NOTE: Each full rotation on the depth-adjustment handle changes the height by $1/16$ " . For example, $1/4$ of a rotation is $1/64$ " , $1/2$ of a rotation is $1/32$ " , and 1 full rotation is $1/16$ " .

- For optimum planing performance, the depth of cut should be $1/32$ " or less per pass. Run the board a few times before adding depth to ensure the best possible cuts.
- Boards should be planed with shallow cuts until the work has a level side (or alternatively the use of a power jointer can be employed). Once a level surface has been created, flip the lumber and create parallel sides.
- Plane alternate sides until the desired thickness is obtained. When half of the total depth of cut is taken from each side, the board will have a uniform moisture content. Any additional drying should not cause it to warp.
- Depth of cut should be shallower when work is wider.
- When planing hardwood, make light cuts or plane the wood in thin widths.
- Make a test cut with a test piece and verify the thickness produced.
- Check accuracy of test cut prior to working on finished product.

OPERATION

PREPARING WORK

Thickness planers work best when at least one side of the lumber is flat. Use a surface planer or a jointer to create a flat surface. Twisted or severely warped boards can jam the planer and should not be used. Rip lumber in half to reduce magnitude of warp.

Work should be fed into the planer in same direction as the grain of the wood. Sometimes the grain will change direction in the middle of the board. In such cases, if possible, cut the board in the middle before planing, so that the grain direction is correct.

 **WARNING!** Never plane against the grain direction of the wood. Do not plane end grain, as the wood could splinter or possibly explode.

 **WARNING!** Do not plane any board shorter than 14-1/2"; the force of the cut could split the board and cause kickback.

CHECK FOR WORN BLADES

The blades' condition will affect cutting precision. Observe the quality of the cut that the planer produces to check the condition of the blades. Dull blades will tear wood fibers and produce fuzzy surfaces. Raised grain will occur when dull blades pound on wood that has varying density. Raised edges will also be produced where the blades have been nicked. Blades on this planer are reversible and should always be reversed or replaced as a matched set. Keeping a spare set of blades on hand is recommended. Replacement blades can be ordered from wenproducts.com.

AVOIDING SNIPE

Thickness planers tend to leave a small bit of snipe at the end of the planed boards, particularly for longer workpieces. Snipe is a small dip that is caused by the board's own weight pulling one end downwards as the board enters or exits the planer, thus pushing the other end into the cutterhead and creating an uneven finish. Snipe will occur when boards are not supported properly or when only one feed roller is in contact with the work at beginning or end of cut.

The best way of avoiding snipe is to cut your lumber long enough that you can saw off the snipe after the board has been planed. Leave 1-2" on both ends so it can be removed later. Other less efficient ways include gently pushing the board up while feeding the work until the outfeed roller starts advancing it. Then, move to the rear and receive the planed board by gently pushing it up when the infeed roller loses contact with it. The third option is to have another dummy board flush against the beginning and end of the workpiece. That way, this piece of scrap wood will be the recipient of all of the snipe. Snipe is more apparent when deeper cuts are taken. Lower depths help prevent snipe.

It is also recommended to have the infeed and outfeed extension tables slightly inclined upwards to form a V shape, with the difference between the outermost edges of the extension tables and center of granite tables being about 1 mm.

OPERATION

THE DO'S AND DONT'S OF GRAIN DIRECTION

Always plane with the grain of the wood (in the same direction as the grain). There are six sides to every board: two face grains, two side/edge grains, and two end grains. Never plane with the end grain facing upwards. Only plane side and face grains. Otherwise, the board has a chance of splintering and exploding inside of the planer, which could cause serious injury and damage.

When planing the face and side/edge grain, always plane in the direction of the grain. Do not plane perpendicular to the grain, otherwise the board also has a chance of splintering and exploding.

⚠ WARNING! Never plane against grain direction of the wood. Do not plane end grain, as the wood could splinter or possibly explode.

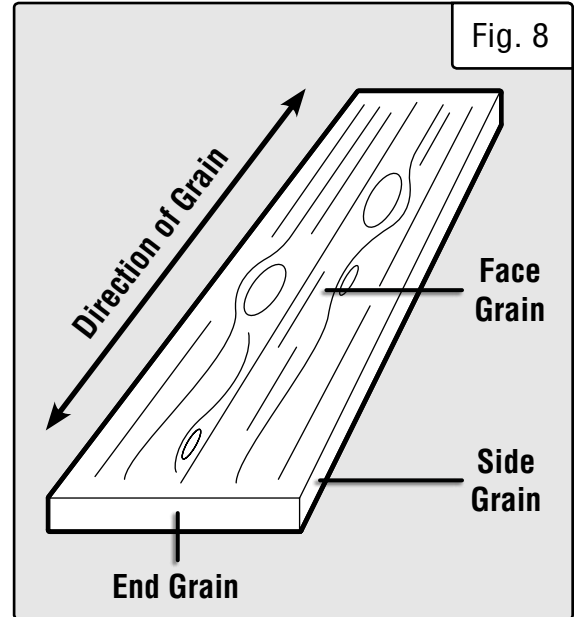

FEEDING WORK

The planer is supplied with planing blades mounted in the cutterhead with the infeed and outfeed rollers pre-adjusted to the correct heights. The feed rate is automatic but will vary slightly depending on the type of wood (feed rate refers to the rate at which the lumber travels through the planer). To feed the workpiece:

1. Align the work perpendicular to the rollercase so that the work feeds through the planer straight, making sure that the board is traveling in the same direction as the grain and that you are only planing either side or face grain. Boards longer than 24" should have additional support from free standing material stands. Position the workpiece with the face to be planed on top.
2. Raise / lower rollercase to produce the depth of cut desired.
3. Stand on the side of the planer. Do not stand directly in front or behind the planer.
4. Turn the planer on and direct the board into the planer. Gently slide workpieces into the infeed side of the planer until the infeed roller advances the workpiece. Let go of the workpiece and allow the automatic feed to advance the board through the planer.
5. Do not push / pull on workpiece. Catch the planed lumber by grasping it in same manner as it was fed as it comes out the back side. Make sure not to stand directly behind the planer while catching fed lumber. Do not grasp any portion of board which has not gone past the out-feed roller.

CAUTION: To avoid risk of injury due to kickback, do not stand directly in line with the front or rear of planer.

6. Repeat as needed. The planer has two return rollers on top so an assistant can pass the work back to the operator. Keep in mind that multiple shallow cuts result in smoother surfaces than a single deeper cut.

NOTE: Assistant must follow same precautions as operator.

MAINTENANCE

CHANGING BLADES

⚠ WARNING! Always turn the planer OFF and disconnect it from the power source before starting any maintenance work.

For video instructions, visit: <http://bit.ly/planerblades>

NOTE: Although the instructions in the video depict model 6550, the procedure is very similar for model 6552.

Blades should always be reversed or replaced as a matched set (at the same time).

1. Remove the dust chute (Fig. 9 - 1) by unscrewing the thumb screws (Fig. 9 - 2).

2. Loosen and remove the four hex screws (Fig. 10 - 1) from the blade guard on the rear side of the cutterhead. Remove the blade guard.

3. Carefully turn the cutterhead by hand until it is stopped by the self-engaging latch.

4. Loosen and remove the six bolts from the gib (Fig. 11).

5. Remove the gib using the provided magnets (Fig. 12).

CAUTION: Blade edges are extremely sharp. Keep fingers away from the blades at all times.

6. The blade is located in position by two pins. Gently lift the old blades from the cutterhead using magnets. Do not make contact with the blade using fingers. Use magnets only.

7. Reverse or replace blade and carefully position it on the two pins using magnets.

8. Replace the gib and align the holes on the gib with holes on the blade using the magnets.

9. Secure the gib to the cutterhead using the six bolts removed earlier.

10. Depress the latch to release the cutterhead and turn the cutterhead by hand until it is stopped by the self-engaging latch.

11. Repeat the steps above for changing the second and third blades.

12. Replace the blade guard and secure it using the four screws removed earlier. Replace the dust chute.

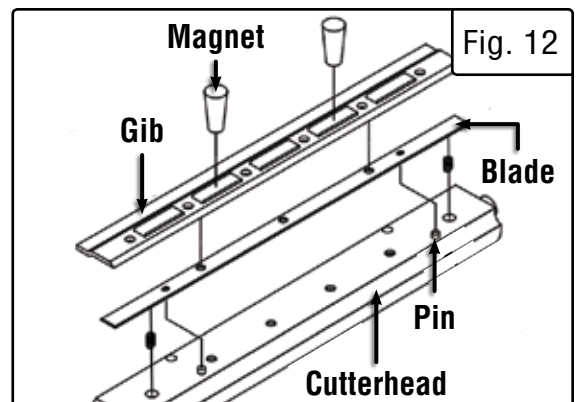
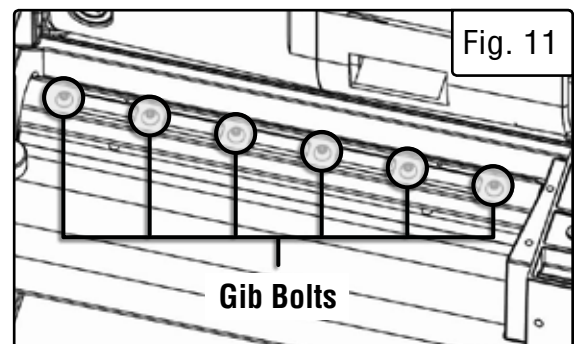
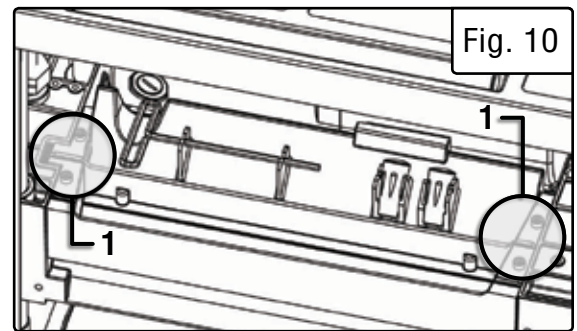
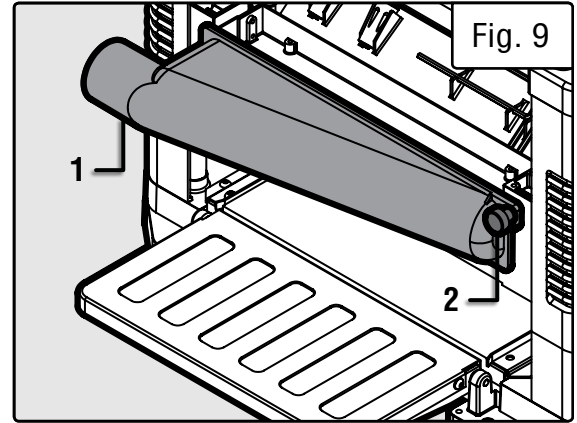

MAINTENANCE

⚠ WARNING! Turn planer off and disconnect from power source before performing any maintenance.

BRUSH INSPECTION AND REPLACEMENT

Brush life depends on the load of the motor. Regularly inspect brushes after 100 hours of use. Brushes are located on either side of the planer motor, on both the front and rear side of the planer.

Loosen brush cap (Fig. 13 - 1) and carefully remove brush from motor. Replace brushes if the spring is damaged. Replace brushes if the carbon is worn down to 3/16" long or shorter. Tighten brush caps after replacement.

LUBRICATION

The motor and cutterhead bearings are sealed and need no lubrication. Keep the elevation leadscrews and elevation gears (located under the planer base) free of dust and debris. Use a dry lubricating agent (such as PTFE) to grease these components as needed.

CLEANING THE PLANER

Keep planer clean of any wood chips, dust, dirt or debris. We strongly recommend always using a dust collection system. After 10 hours of operation, the chains and gears should have wood chips, dust and old grease removed. Use common automotive bearing grease to lubricate all chains and gears. Be sure all chains and gears have plenty of grease. Clean the granite table and infeed / outfeed rollers using a soft, damp cloth. Do not use any waxes, oils or solvents on the table.

NOTE: the buildup of dust, wood shavings, and other debris can significantly shorten the planer's useful life. Keep your planer clean! Failure to do so will void the warranty.

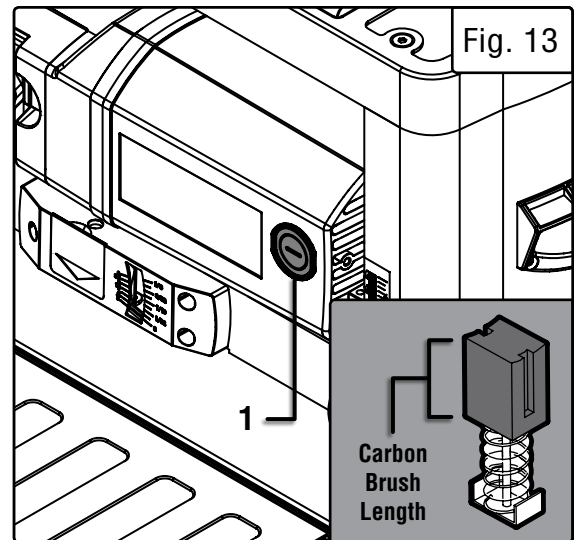

TROUBLESHOOTING GUIDE

ADJUSTING INFEED / OUTFEED EXTENSION TABLE

We recommend setting your infeed and outfeed tables so that the ends of the table extensions are approximately 1mm above the top of the granite table.

1. Locate the table elevation adjustment screw and nut on both sides of the planer, next to the hinge (Fig. 14).
2. Raise the extension table to expose the screws (Fig. 15).
3. Using two 10 mm wrenches or a suitable Phillips screwdriver, loosen the screw by holding the nut with a wrench and turning the screw head counterclockwise.

NOTE: Keep track of the number of turns you apply to each screw. Make sure that both the left- and right-hand screws on the table are turned the same number of times.

4. When both screws are adjusted to the height you want the table to be, tighten down the nut against the base of the planer by holding the screw head with a wrench or Phillips screwdriver and turning the nut clockwise. Repeat for the other screw.

5. Test the table height. If adjustments need to be made, repeat steps 3 to 4 as needed, ensuring that both screws have been turned the same number of times.

6. Repeat steps 1-5 on the other table until you are satisfied with the height.

7. Test the adjustments on a scrap piece of wood, making further adjustments as necessary until you are satisfied.

If the material does not feed properly, check for:

- Dull blades: rotate or replace as necessary (refer to Changing Blades section).
- Excess clogging in the dust chute (refer to Attach Dust Chute in the Assembly and Adjustments section).
- A broken V-Belt (contact customer service at **1-800-232-1195, M-F, 8-5 CST** for assistance).

If the circuit breaker trips repeatedly:

- The blades may be dull. Dull blades can cause motor overloading. Rotate or replace as necessary (refer to Changing Blades section).
- Reduce the depth of cut. An overly aggressive cut could cause motor overloading (refer to Depth of Cut in the section).

If the unit does not run, check to see:

- If the unit is plugged in. Ensure unit is plugged into the appropriate outlet (refer to Electrical Information).
- If the circuit breaker needs to be reset.
- If the motor brushes are worn out. Replace as necessary (refer to Brush Inspection and Replacement section).



EXPLODED VIEW & PARTS LIST

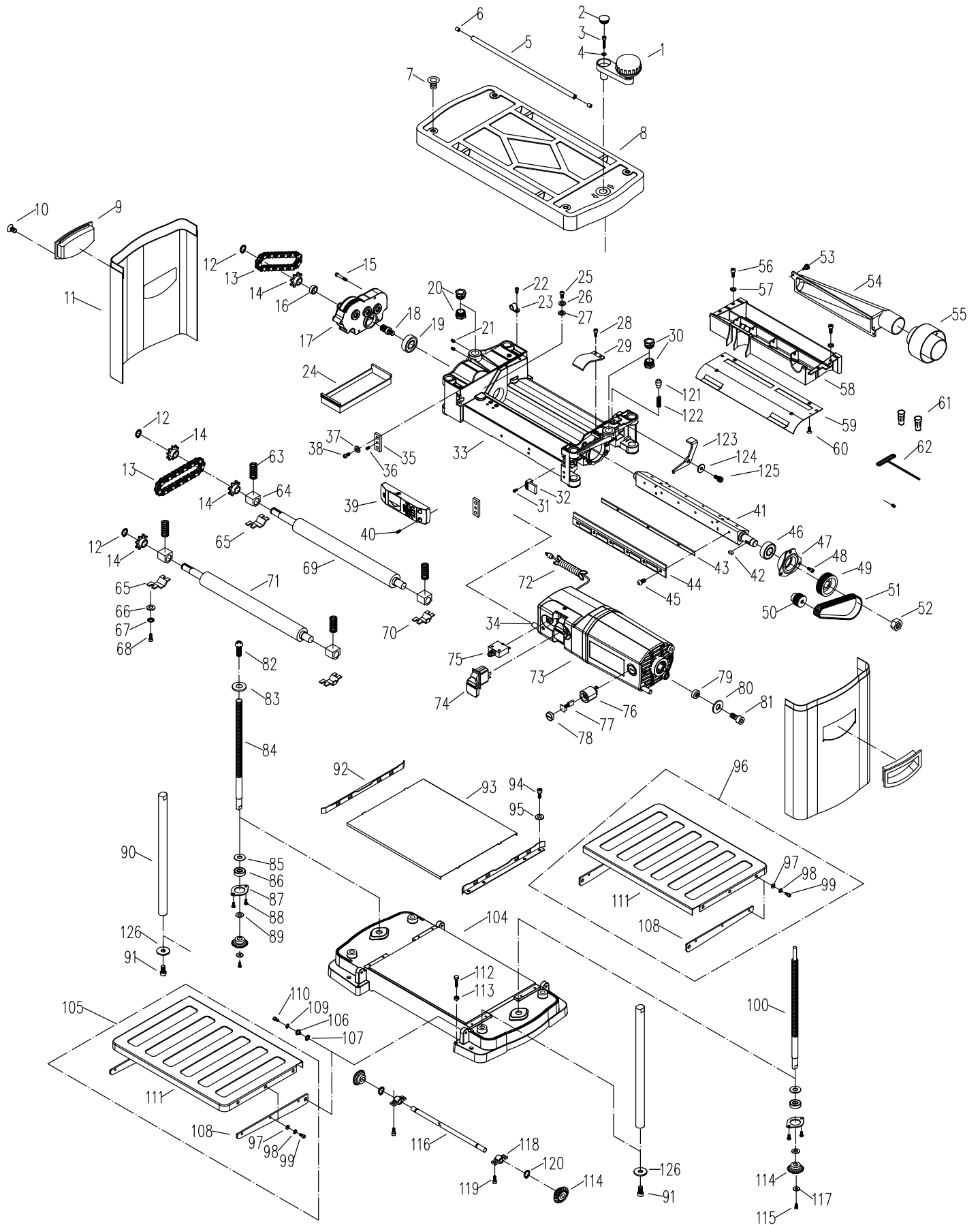

EXPLODED VIEW & PARTS LIST

No.	Part No.	Description	Qty
1	6550-105	Handle Assembly	1
2		Cap	1
3		Socket Head Screw	1
4		Flat Washer	1
5	6552-005	Roller	2
6	6552-006	Roller Cap	4
7	6552-007	Flat Head Screw	4
8	6552-008	Top Cover	1
9	6552-009	Grip	2
10	6552-010	Flat Head Screw	4
11	6552-011	Left Cover	2
12	6552-012	Retaining Ring	3
13	6550-215	Chain	2
14	6550-216	Sprocket	4
15	6552-015	Socket Head Screw	4
16	6550-217	Spacer	1
17	6550-219	Gear Box Assembly	1
18	6550-220	Pinion	1
19	6550-221	Ball Bearing	1
20	6550-139	Elevating Nut (LH)	2
21	6550-233	Set Screw	4
22	6552-022	Cable Clamp	1
23	6550-228	Socket Head Screw	1
24	6552-024	Chain Cover	1
25	6552-025	Pan Head Screw	2
26	6552-026	Lock Washer	2
27	6552-027	Serrated Washer	2
28	6552-028	Socket Head Screw	2
29	6552-029	Belt Cover	1
30	6550-108	Elevating Nut (RH)	2
31	6552-031B	Pan Head Screw, M5	2
32	6550-259B	Depth Indicator, M5 Holes	1
33	6552-033C	Rollercase	1
34	6552-034B	Motor Pivot Rod	1
35	6552-035	Rod Clamp	2
36	6552-036	Set Screw	2
37	6552-037	Lock Washer	4
38	6552-038	Pan Head Screw	4
39	6552-039	Depth-Of-Cut Gauge	1
40	6552-040	Pan Head Screw	3
41	6552-041	Cutterhead	1
42	6552-042	Key	1

No.	Part No.	Description	Qty
43	6552-043	Blade	3
44	6552-044	Blade Clamp	3
45	6552-045	Socket Head Screw	16
46	6552-046	Ball Bearing	1
47	6550-250	Bearing House	1
48	6552-048	Pan Head Screw	3
49	6552-049	Cutterhead Pulley	1
50	6552-050	Motor Pulley	1
51	6550-246	Belt	1
52	6550-245	Hex Nut	1
53	6550-202	Screw	2
54	6550-201	Dust Exhaust Port	1
55	6552-055	Connecting Port	1
56	6552-056	Socket Head Screw	4
57	6552-057	Flat Washer	4
58	6552-058	Dust Chute	1
59	6552-059	Chute Plate	1
60	6552-060	Flat Head Tap Screw	4
61	6550-137	Hex Wrench	1
62	6550-138	Magnet	2
63	6552-063	Spring	4
64	6550-252	Bearing Block	4
65	6550-257	LH Retainer	2
66	6552-066	Flat Washer	8
67	6552-067	Lock Washer	8
68	6552-068	Socket Head Screw	8
69	6552-069	Outfeed Roller	1
70	6552-070	Rh Retainer	2
71	6552-071	Infeed Roller	1
72	6552-072	Power Cord	1
73	6552-073B	Motor	1
74	6550-210	Switch	1
75	6550-260	Circuit Breaker	1
76	6550-211	Brush Holder	2
77	6550-212	Brush	2
78	6550-213	Brush Cap	2
79	6552-079	Spacer	1
80	6552-080	Flat Washer	1
81	6552-081	Socket Head Screw	1
82	6552-082	Socket Head Screw	1
83	6552-083	Flat Washer	1
84	6550-112	Elevating Screw (LH)	1
85	6552-085B	Flat Washer	2

No.	Part No.	Description	Qty
86	6552-086B	Ball Bearing	2
87	6552-087B	Bearing Retainer Plate	2
88	6552-088B	Socket Pan Head Screw	4
89	6552-089B	Flat Washer	2
90	6552-090B	Column	4
91	6552-091B	Socket Head Screw	4
92	6552-092	Guide	2
93	6552-093	Table	1
94	6552-094	Socket Head Screw	8
95	6552-095	Flat Washer	8
96	6552-096	Outfeed Extension Table Assembly	1
97	6552-097	Flat Washer	12
98	6552-098	Lock Washer	12
99	6552-099	Socket Pan Head Screw	12
100	6550-117	Elevating Screw (RH)	1
104	6552-104B	Base	1
105	6552-105	Infeed Extension Table	1
106	6550-129	Bushing	4
107	6550-130	Wavy Washer	4
108	6552-108	Table Support	4
109	6552-109	Lock Washer	4
110	6552-110	Socket Head Screw	4
111	6552-111	Extension Table	2
112	6552-112	Hex Head Bolt	4
113	6552-113	Hex Nut	4
114	6550-134	Bevel Gear	4
115	6552-115B	Socket Head Screw	2
116	6550-131	Shaft	1
117	6552-117B	Flat Washer	2
118	6550-132	Support	2
119	6552-119	Socket Head Screw	4
120	6552-120	Retaining Ring	2
121	6552-121	Plunger	1
122	6552-122	Spring	1
123	6552-123	Cutterhead Lock Latch	1
124	6552-124	Washer	1
125	6552-125	Socket Head Screw	1
126	6552-126B	Flat Washer	4

WARRANTY STATEMENT

WEN Products is committed to building tools that are dependable for years. Our warranties are consistent with this commitment and our dedication to quality.

LIMITED WARRANTY OF WEN PRODUCTS FOR HOME USE

GREAT LAKES TECHNOLOGIES, LLC (“Seller”) warrants to the original purchaser only, that all WEN consumer power tools will be free from defects in material or workmanship during personal use for a period of two (2) years from date of purchase or 500 hours of use; whichever comes first. Ninety days for all WEN products if the tool is used for professional or commercial use. Purchaser has 30 days from the date of purchase to report missing or damaged parts.

SELLER’S SOLE OBLIGATION AND YOUR EXCLUSIVE REMEDY under this Limited Warranty and, to the extent permitted by law, any warranty or condition implied by law, shall be the replacement of parts, without charge, which are defective in material or workmanship and which have not been subjected to misuse, alteration, careless handling, misrepair, abuse, neglect, normal wear and tear, improper maintenance, or other conditions adversely affecting the Product or the component of the Product, whether by accident or intentionally, by persons other than Seller. To make a claim under this Limited Warranty, you must make sure to keep a copy of your proof of purchase that clearly defines the Date of Purchase (month and year) and the Place of Purchase. Place of Purchase must be a direct vendor of Great Lakes Technologies, LLC. Purchasing through third party vendors, including but not limited to garage sales, pawn shops, resale shops, or any other secondhand merchant, voids the warranty included with this product. Contact techsupport@wenproducts.com or 1-800-232-1195 with the following information to make arrangements: your shipping address, phone number, serial number, required part numbers, and proof of purchase. Damaged or defective parts and products may need to be sent to WEN before the replacements can be shipped out.

Upon the confirmation of a WEN representative, your product may qualify for repairs and service work. When returning a product for warranty service, the shipping charges must be prepaid by the purchaser. The product must be shipped in its original container (or an equivalent), properly packed to withstand the hazards of shipment. The product must be fully insured with a copy of the proof of purchase enclosed. There must also be a description of the problem in order to help our repairs department diagnose and fix the issue. Repairs will be made and the product will be returned and shipped back to the purchaser at no charge for addresses within the contiguous United States.

THIS LIMITED WARRANTY DOES NOT APPLY TO ITEMS THAT WEAR OUT FROM REGULAR USAGE OVER TIME, INCLUDING BELTS, BRUSHES, BLADES, BATTERIES, ETC. ANY IMPLIED WARRANTIES SHALL BE LIMITED IN DURATION TO TWO (2) YEARS FROM DATE OF PURCHASE. SOME STATES IN THE U.S. AND SOME CANADIAN PROVINCES DO NOT ALLOW LIMITATIONS ON HOW LONG AN IMPLIED WARRANTY LASTS, SO THE ABOVE LIMITATION MAY NOT APPLY TO YOU.

IN NO EVENT SHALL SELLER BE LIABLE FOR ANY INCIDENTAL OR CONSEQUENTIAL DAMAGES (INCLUDING BUT NOT LIMITED TO LIABILITY FOR LOSS OF PROFITS) ARISING FROM THE SALE OR USE OF THIS PRODUCT. SOME STATES IN THE U.S. AND SOME CANADIAN PROVINCES DO NOT ALLOW THE EXCLUSION OR LIMITATION OF INCIDENTAL OR CONSEQUENTIAL DAMAGES, SO THE ABOVE LIMITATION OR EXCLUSION MAY NOT APPLY TO YOU.

THIS LIMITED WARRANTY GIVES YOU SPECIFIC LEGAL RIGHTS, AND YOU MAY ALSO HAVE OTHER RIGHTS WHICH VARY FROM STATE TO STATE IN THE U.S., PROVINCE TO PROVINCE IN CANADA AND FROM COUNTRY TO COUNTRY.

THIS LIMITED WARRANTY APPLIES ONLY TO ITEMS SOLD WITHIN THE UNITED STATES OF AMERICA, CANADA AND THE COMMONWEALTH OF PUERTO RICO. FOR WARRANTY COVERAGE WITHIN OTHER COUNTRIES, CONTACT THE WEN CUSTOMER SUPPORT LINE. FOR WARRANTY PARTS OR PRODUCTS REPAIRED UNDER WARRANTY SHIPPING TO ADDRESSES OUTSIDE OF THE CONTIGUOUS UNITED STATES, ADDITIONAL SHIPPING CHARGES MAY APPLY.