

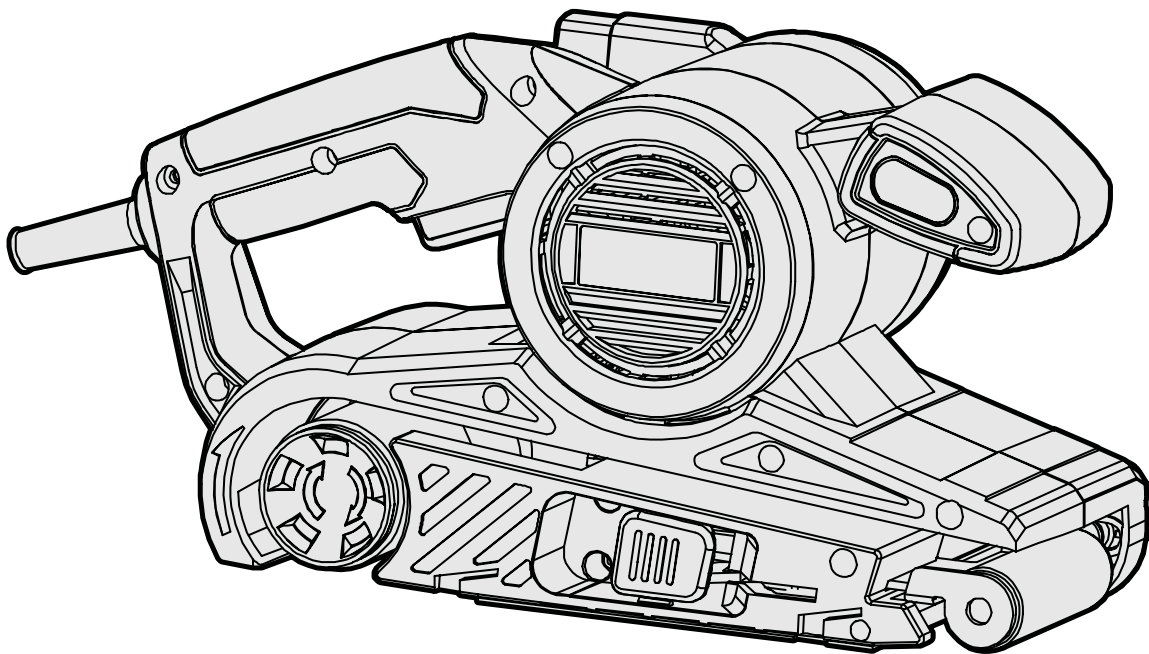

MODEL 6321

3" x 21" BELT SANDER

Instruction Manual



NEED HELP? CONTACT US!

Have product questions? Need technical support? Please feel free to contact us:



1-847-429-9263 (M-F 8AM-5PM CST)



TECHSUPPORT@WENPRODUCTS.COM

IMPORTANT: Your new tool has been engineered and manufactured to WEN's highest standards for dependability, ease of operation, and operator safety. When properly cared for, this product will supply you years of rugged, trouble-free performance. Pay close attention to the rules for safe operation, warnings, and cautions. If you use your tool properly and for its intended purpose, you will enjoy years of safe, reliable service.

For replacement parts and the most up-to-date instruction manuals, visit ***WENPRODUCTS.COM***

CONTENTS

WELCOME	3
Introduction	3
Specifications.....	3
SAFETY	4
General Safety Rules.....	4
Belt Sander Safety Warnings.....	6
Electrical Information.....	7
BEFORE OPERATING	8
Know Your Belt Sander	8
Assembly & Adjustments.....	9
OPERATION & MAINTENANCE	10
Operation	10
Maintenance.....	12
Exploded View & Parts List.....	13
Warranty Statement.....	15

To purchase accessories and replacement parts for your tool, visit ***WENPRODUCTS.COM***

Replacement Sanding Belts (Model 6321SP)

INTRODUCTION

Thanks for purchasing the WEN Belt Sander. We know you are excited to put your tool to work, but first, please take a moment to read through the manual. Safe operation of this tool requires that you read and understand this operator's manual and all the labels affixed to the tool. This manual provides information regarding potential safety concerns, as well as helpful assembly and operating instructions for your tool.

 **SAFETY ALERT SYMBOL:** Indicates danger, warning, or caution. The safety symbols and the explanations with them deserve your careful attention and understanding. Always follow the safety precautions to reduce the risk of fire, electric shock or personal injury. However, please note that these instructions and warnings are not substitutes for proper accident prevention measures.

NOTE: The following safety information is not meant to cover all possible conditions and situations that may occur. WEN reserves the right to change this product and specifications at any time without prior notice.

At WEN, we are continuously improving our products. If you find that your tool does not exactly match this manual, please visit wenproducts.com for the most up-to-date manual or contact our customer service at **1-847-429-9263**.

Keep this manual available to all users during the entire life of the tool and review it frequently to maximize safety for both yourself and others.

SPECIFICATIONS

Model Number	6321
Motor	120V, 60 Hz, 7A
Speed	820 FPM
Belt Size	3 in. x 21 in.
Product Weight	6.1 Pounds
Product Dimensions	13.7 in. x 5.9 in. x 6.3 in.

GENERAL SAFETY RULES

 **WARNING!** Read all safety warnings and all instructions. Failure to follow the warnings and instructions may result in electric shock, fire and/or serious injury.

Safety is a combination of common sense, staying alert and knowing how your item works. The term “power tool” in the warnings refers to your mains-operated (corded) power tool or battery-operated (cordless) power tool.

SAVE THESE SAFETY INSTRUCTIONS.

WORK AREA SAFETY

- 1. Keep work area clean and well lit.** Cluttered or dark areas invite accidents.
- 2. Do not operate power tools in explosive atmospheres, such as in the presence of flammable liquids, gases or dust.** Power tools create sparks which may ignite the dust or fumes.
- 3. Keep children and bystanders away while operating a power tool.** Distractions can cause you to lose control.

ELECTRICAL SAFETY

- 1. Power tool plugs must match the outlet. Never modify the plug in any way. Do not use any adapter plugs with earthed (grounded) power tools.** Unmodified plugs and matching outlets will reduce risk of electric shock.
- 2. Avoid body contact with earthed or grounded surfaces such as pipes, radiators, ranges and refrigerators.** There is an increased risk of electric shock if your body is earthed or grounded.
- 3. Do not expose power tools to rain or wet conditions.** Water entering a power tool will increase the risk of electric shock.
- 4. Do not abuse the cord. Never use the cord for carrying, pulling or unplugging the power tool. Keep cord away from heat, oil, sharp edges or moving parts.** Damaged or entangled cords increase the risk of electric shock.
- 5. When operating a power tool outdoors, use an extension cord suitable for outdoor use.** Use of a cord suitable for outdoor use reduces the risk of electric shock.

- 6. If operating a power tool in a damp location is unavoidable, use a ground fault circuit interrupter (GFCI) protected supply.** Use of a GFCI reduces the risk of electric shock.

PERSONAL SAFETY

- 1. Stay alert, watch what you are doing and use common sense when operating a power tool. Do not use a power tool while you are tired or under the influence of drugs, alcohol or medication.** A moment of inattention while operating power tools may result in serious personal injury.
- 2. Use personal protective equipment. Always wear eye protection.** Protective equipment such as a respiratory mask, non-skid safety shoes and hearing protection used for appropriate conditions will reduce the risk of personal injury.
- 3. Prevent unintentional starting. Ensure the switch is in the off-position before connecting to power source and/or battery pack, picking up or carrying the tool.** Carrying power tools with your finger on the switch or energizing power tools that have the switch on invites accidents.
- 4. Remove any adjusting key or wrench before turning the power tool on.** A wrench or a key left attached to a rotating part of the power tool may result in personal injury.
- 5. Do not overreach. Keep proper footing and balance at all times.** This enables better control of the power tool in unexpected situations.
- 6. Dress properly. Do not wear loose clothing or jewelry. Keep your hair and clothing away from moving parts.** Loose clothes, jewelry or long hair can be caught in moving parts.

GENERAL SAFETY RULES

 **WARNING!** Read all safety warnings and all instructions. Failure to follow the warnings and instructions may result in electric shock, fire and/or serious injury.

Safety is a combination of common sense, staying alert and knowing how your item works. The term “power tool” in the warnings refers to your mains-operated (corded) power tool or battery-operated (cordless) power tool.

SAVE THESE SAFETY INSTRUCTIONS.

7. If devices are provided for the connection of dust extraction and collection facilities, ensure these are connected and properly used. Use of dust collection can reduce dust-related hazards.

POWER TOOL USE AND CARE

1. Do not force the power tool. Use the correct power tool for your application. The correct power tool will do the job better and safer at the rate for which it was designed.

2. Do not use the power tool if the switch does not turn it on and off. Any power tool that cannot be controlled with the switch is dangerous and must be repaired.

3. Disconnect the plug from the power source and/or the battery pack from the power tool before making any adjustments, changing accessories, or storing power tools. Such preventive safety measures reduce the risk of starting the power tool accidentally.

4. Store idle power tools out of the reach of children and do not allow persons unfamiliar with the power tool or these instructions to operate the power tool. Power tools are dangerous in the hands of untrained users.

5. Maintain power tools. Check for misalignment or binding of moving parts, breakage of parts and any other condition that may affect the power tool's operation. If damaged, have the power tool repaired before use. Many accidents are caused by poorly maintained power tools.

6. Keep cutting tools sharp and clean. Properly maintained cutting tools with sharp cutting edges are less likely to bind and are easier to control.

7. Use the power tool, accessories and tool bits, etc. in accordance with these instructions, taking into account the working conditions and the work to be performed. Use of the power tool for operations different from those intended could result in a hazardous situation.

8. Use clamps to secure your workpiece to a stable surface. Holding a workpiece by hand or using your body to support it may lead to loss of control.

9. KEEP GUARDS IN PLACE and in working order.

SERVICE

1. Have your power tool serviced by a qualified repair person using only identical replacement parts. This will ensure that the safety of the power tool is maintained.

CALIFORNIA PROPOSITION 65 WARNING

Some dust created by power sanding, sawing, grinding, drilling, and other construction activities may contain chemicals, including lead, known to the State of California to cause cancer, birth defects, or other reproductive harm. Wash hands after handling. Some examples of these chemicals are:

- Lead from lead-based paints.
- Crystalline silica from bricks, cement, and other masonry products.
- Arsenic and chromium from chemically treated lumber.

Your risk from these exposures varies depending on how often you do this type of work. To reduce your exposure to these chemicals, work in a well-ventilated area with approved safety equipment such as dust masks specially designed to filter out microscopic particles.

BELT SANDER SAFETY WARNINGS

 **WARNING!** Do not operate the power tool until you have read and understood the following instructions and the warning labels.

BELT SANDER SAFETY

1. Wait for the belt to stop before setting the tool down. An exposed rotating belt may engage the surface, leading to possible loss of control and serious injury.
2. Hold the power tool by the insulated gripping surfaces only in case the belt contacts its own cord. Cutting a “live” wire may make exposed metal parts of the tool “live” and could give the operator an electric shock.
3. Secure the workpiece to a stable platform using clamps or another practical method. Holding the work by hand or against the body leaves is unstable and could lead to a loss of control.
4. Secure the material being sanded. Never hold it in your hand or across your legs. Small workpieces must be adequately secured so that the rotating belt doesn’t pick them up during the forward motion of the sander. Unstable support causes the belt to bind, resulting in a loss of control and possible injury.
5. Always start the sander before the sandpaper is in contact with the workpiece. Let the sander reach full speed before using the tool.
6. Check the workpiece for nails. If there are nails, either remove them or set them well below the intended finished surface so that they do not come in contact with the surface of the sander.
7. Unplug the tool before changing accessories. Accidental start-ups may occur if the tool is plugged in during an accessory change. Before plugging the tool back in, check that the trigger is OFF.
8. After changing sandpaper, rotate the sandpaper to make sure the sandpaper doesn’t hit any part of the tool.
9. Always hold the tool firmly with both hands for maximum control.
10. Never pull the tool backwards over the workpiece. Loss of control may occur.
11. GFCI and personal protection devices such as electrician’s rubber gloves and footwear will increase personal safety.
12. Keep handles and hands dry, clean and free from oil and grease. Slippery surfaces cannot safely maintain control of the power tool.
15. Develop a periodic maintenance schedule for your tool. When cleaning a tool be careful not to disassemble any portion of the tool. Internal wires may be misplaced or pinched and safety guard return springs may be improperly mounted.
16. Certain cleaning agents such as gasoline, carbon tetrachloride, ammonia, etc. may damage plastic parts.

ELECTRICAL INFORMATION

DOUBLE-INSULATED TOOLS

The tool's electrical system is double-insulated where two systems of insulation are provided. This eliminates the need for the usual three-wire grounded power cord. Double-insulated tools do not need to be grounded, nor should a means for grounding be added to the product. All exposed metal parts are isolated from the internal metal motor components with protecting insulation.

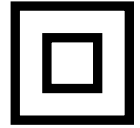

IMPORTANT: Servicing a double-insulated product requires extreme care and knowledge of the system, and should be done only by qualified service personnel using identical replacement parts. Always use original factory replacement parts when servicing.

1. Polarized Plugs. To reduce the risk of electric shock, this equipment has a polarized plug (one blade is wider than the other). This plug will fit in a polarized outlet only one way. If the plug does not fit fully in the outlet, reverse the plug. If it still does not fit, contact a qualified electrician to install a proper outlet. Do not modify the machine plug or the extension cord in any way.

2. Ground fault circuit interrupter protection (GFCI) should be provided on the circuit or outlet used for this power tool to reduce the risk of electric shock.

3. Service and repair. To avoid danger, electrical appliances must only be repaired by a qualified service technician using original replacement parts.

GUIDELINES AND RECOMMENDATIONS FOR EXTENSION CORDS

When using an extension cord, be sure to use one heavy enough to carry the current your product will draw. An undersized cord will cause a drop in line voltage, resulting in loss of power and overheating. The table below shows the correct size to be used according to cord length and ampere rating. When in doubt, use a heavier cord. The smaller the gauge number, the heavier the cord.

AMPERAGE	REQUIRED GAUGE FOR EXTENSION CORDS			
	25 ft.	50 ft.	100 ft.	150 ft.
7A	18 gauge	16 gauge	14 gauge	12 gauge

1. Examine extension cord before use. Make sure your extension cord is properly wired and in good condition. Always replace a damaged extension cord or have it repaired by a qualified person before using it.

2. Do not abuse extension cord. Do not pull on cord to disconnect from receptacle; always disconnect by pulling on plug. Disconnect the extension cord from the receptacle before disconnecting the product from the extension cord. Protect your extension cords from sharp objects, excessive heat and damp/wet areas.

3. Use a separate electrical circuit for your tool. This circuit must not be less than a 12-gauge wire and should be protected with a 15A time-delayed fuse. Before connecting the motor to the power line, make sure the switch is in the OFF position and the electric current is rated the same as the current stamped on the motor nameplate. Running at a lower voltage will damage the motor.

KNOW YOUR BELT SANDER

UNPACKING

Carefully remove the belt sander from the packaging and place it on a sturdy, flat surface. Make sure to take out all contents and accessories. Do not discard the packaging until everything is removed. If any part is missing or broken, please contact customer service at **1-847-429-9263** (M-F 8-5 CST), or email techsupport@wenproducts.com.

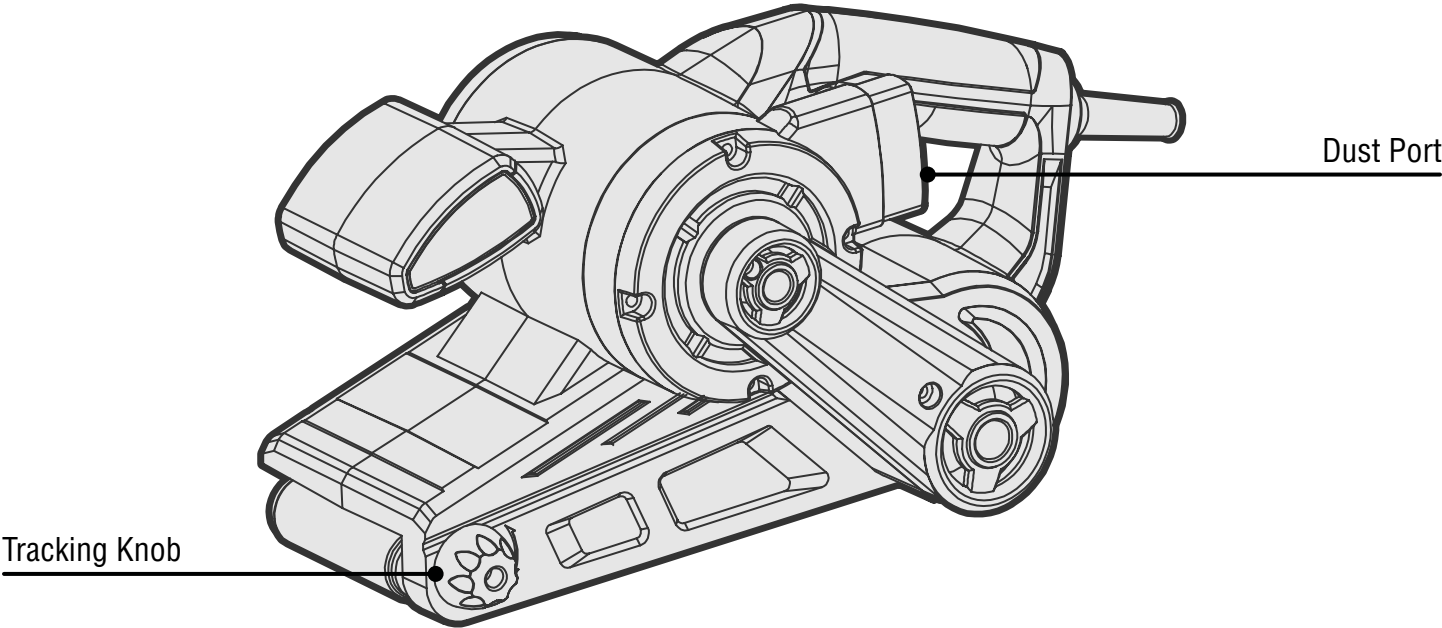
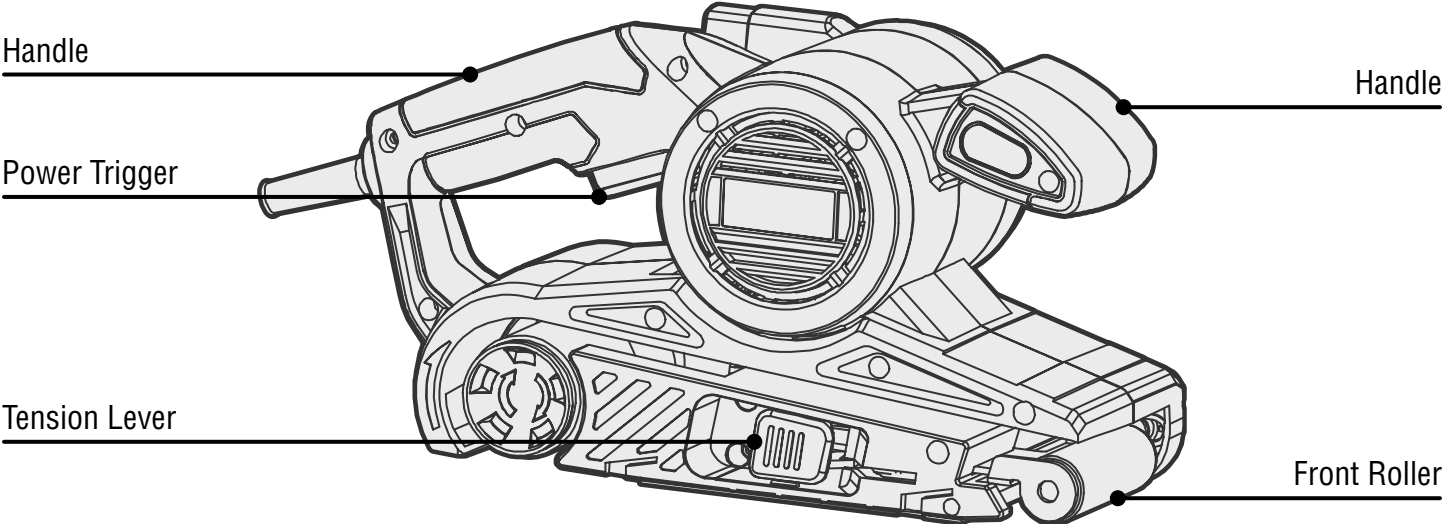

ASSEMBLY & ADJUSTMENTS

CHOOSING SANDING BELTS

Sanding belts come in different grades from rough to smooth. Select the grade required for the particular job. Refer to the table below for the type and applications of different grades. Your sander comes with one 80-grit sanding belt. Additional sanding belts of various grits can be purchased from wenproducts.com.

NOTE: Do not use the same sanding belt for wood and metal. Avoid creasing by storing belts in hanging positions.

Material	Grit
Sanding Softwood	60 - 240
Sanding Hardwood	60 - 180
Sanding Chipboard	60 - 150
Removing Paint/Varnish	60
Whetting Paints	150 - 320
De-Rusting Steel	40 - 120
Sanding Plastics	120 - 240
Nonferrous Metals (ie. Aluminum)	80 - 150

⚠ WARNING! To avoid injury from accidental startups, make sure the tool is OFF and unplugged from the power source before making any adjustments.

INSTALLING OR REPLACING THE SANDING BELT

1. Make sure that the sander is OFF and unplugged from the power source.
2. Turn the tool upside down and pull out the belt tension lever (Fig. 1 - 1) to retract the front roller (Fig. 1 - 2) to loosen the belt's tension.
3. Slide the sanding belt off.
4. Mount a new sanding belt on the rollers. Make sure that the arrow on the inside of the belt is pointing the same direction as indicated on the tool. Check to make sure that the sanding belt does not touch the sides of the casing before turning on the machine.
5. Carefully push the tension lever back to the original position, making sure that it has fully closed.
6. Check that the new belt runs on the center of the rollers. Do this by starting the belt sander to watch how the sanding belt runs. If it shifts along the rollers towards the left or the right, it will require adjustments.
7. To adjust the sanding belt, use the tracking adjustment knob (Fig. 2 - 1), turning it either clockwise or counterclockwise to adjust the angle of the front roller. Run the sander for a short period of time and adjust the tracking until the sanding belt is running in the center of the roller.

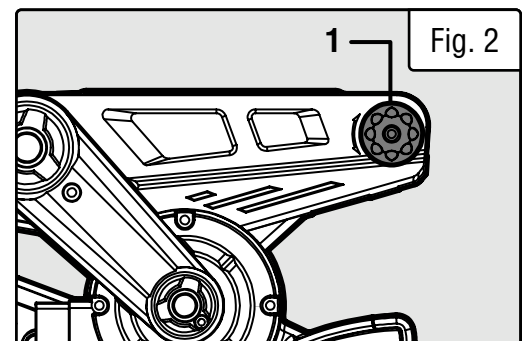
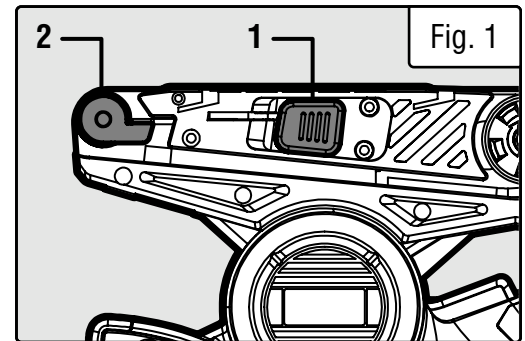

OPERATION

DUST COLLECTION

The dust produced by sanding can be hazardous to your health. Always wear a dust mask and operate the tool in a well-ventilated area. This sander comes with a dust collection bag. Before operating the sander, make sure to install the dust bag.

⚠ CAUTION! When sanding metal, the dust bag or dust extraction system should not be used, as there may be a risk of fire due to flying sparks.

⚠ WARNING! Do not allow the workpiece to overheat. This can cause a fire if the wood dust is mixed with other chemicals, paint residues or metal residues. Always empty the dust bag and vacuum used before leaving the work station.

INSTALLING DUST COLLECTION BAG

1. Fit the end of the dust bag securely over the dust port (Fig. 3 - 1).

REMOVING & EMPTYING THE DUST COLLECTION BAG

1. Turn the sander OFF and unplug it from the power source, then pull the dust bag assembly off the dust port. Open the zipper over a garbage can and empty the bag. **NOTE:** Check and empty dust bag often, before it gets full.

⚠ CAUTION! Wear respiratory protection when emptying the bag.

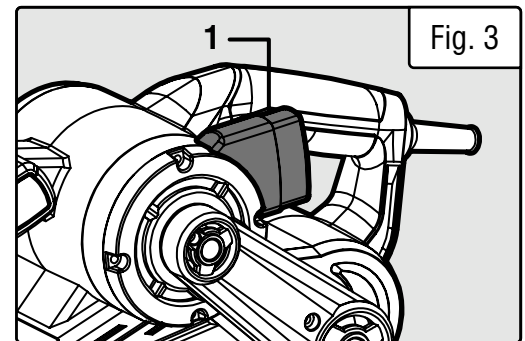

OPERATION

⚠ CAUTION! Never cover the air vents. They must always be open for proper motor cooling. Make sure that the work piece is free of nails and other foreign objects that could tear the abrasive belt.

OPERATING THE BELT SANDER

1. Hold machine firmly with both hands, one hand on the front handle and one hand on the back handle, and assume a balanced position.
2. Pull the trigger switch (Fig. 4 - 1) and allow the motor to reach full speed. For continuous operation, press in the power lock-on button (Fig. 4 - 2) located on the side of the handle.
3. Hold the machine parallel to the work piece. Gently bring belt into contact with the surface.

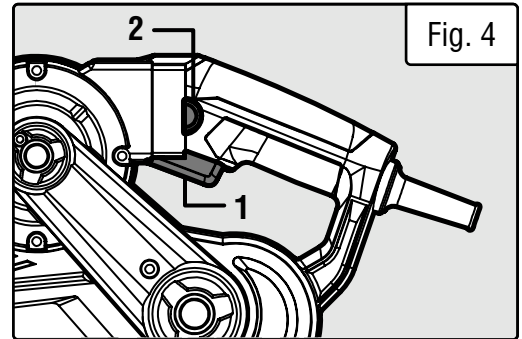

⚠ CAUTION! The sander may initially lunge forward. Resist the forward motion and keep the belt sander moving at an even pace.

Never exert excessive pressure on the tool. The weight of the tool applies adequate pressure. Excessive pressure prevents proper sanding, leaving an uneven finish, and excess wear to both the tool and the abrasive belt.

4. Once finished with your sanding operation, lift the belt sander off the work piece before turning the tool OFF. Wait until the belt has stopped rotating before setting down the tool on its side.

⚠ CAUTION! If the sander makes an unfamiliar sound or vibrates excessively switch it off immediately and disconnect from the power supply. Investigate the cause or consult a service center for advice.

MAINTENANCE

⚠ WARNING! To avoid accidents, make sure the tool is OFF and unplugged from the power source before cleaning or performing any maintenance. Servicing of the tool must be performed by a qualified technician.

SERVICE

Preventive maintenance performed by unauthorized personnel may result in misplacing of internal wires and components, possibly causing a serious hazard. Call WEN customer service line at **1-847-429-9263** for product support.

CLEANING

Ventilation openings and switch levers must be kept clean and free of foreign matter. The tool may be cleaned most effectively with compressed dry air. Do not attempt to clean these components by inserting pointed objects through openings. Certain cleaning agents and solvents damage plastic parts; this includes but is not limited to gasoline, carbon tetrachloride, chlorinated cleaning solvents, ammonia and household detergents that contain ammonia.

NOTE: Follow instructions in section “INSTALLING OR REPLACING THE SANDING BELT” to regularly change the sanding belt, for optimal safety and quality of sanding.

NOTE: Follow instructions in section “REMOVING & EMPTYING THE DUST COLLECTION BAG” to regularly empty the contents of the dust bag. Use a dry cloth to clean and make sure ventilation openings are always clear.

REPLACING THE DRIVE BELT

1. Locate the drive belt cover (Fig. 5 - 1) on the side of the machine.
2. Remove the two screws (Fig. 6 - Circled) with a screwdriver (not included) and take off the drive belt cover to expose the drive belt.
3. Note the position of the belt in relation to the pulleys. Rotate the large drive pulley (lower) and at the same time ease the drive belt off the motor pulley (upper).
4. Remove the drive belt and place the new drive belt over the large drive pulley. Rotate the drive pulley and at the same time ease the belt onto the motor pulley.
5. Ensure that the new drive belt is correctly located on both pulleys. Make sure the drive belt rotates freely by hand and does not bind or try to jump off the pulleys.
6. Replace the drive belt cover and secure with the four screws.

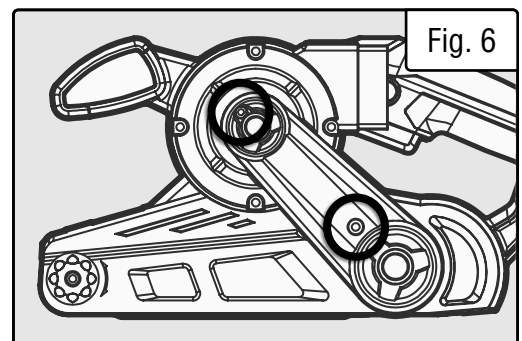
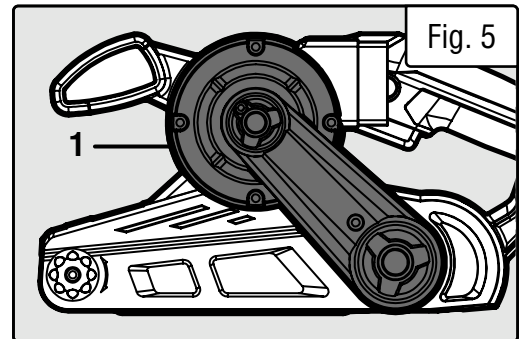

EMPTYING THE DUST BAG

Although the dust bag has a substantial capacity, it should be emptied frequently. Open the zipper of the dust bag over a garbage can to thoroughly clean the dust bag.

⚠ CAUTION! Wear respiratory protection when emptying the bag.

PRODUCT DISPOSAL

Used power tools should not be disposed of together with household waste. This product contains electronic components that should be recycled. Please take this product to your local recycling facility for responsible disposal and to minimize its environmental impact.

EXPLODED VIEW & PARTS LIST

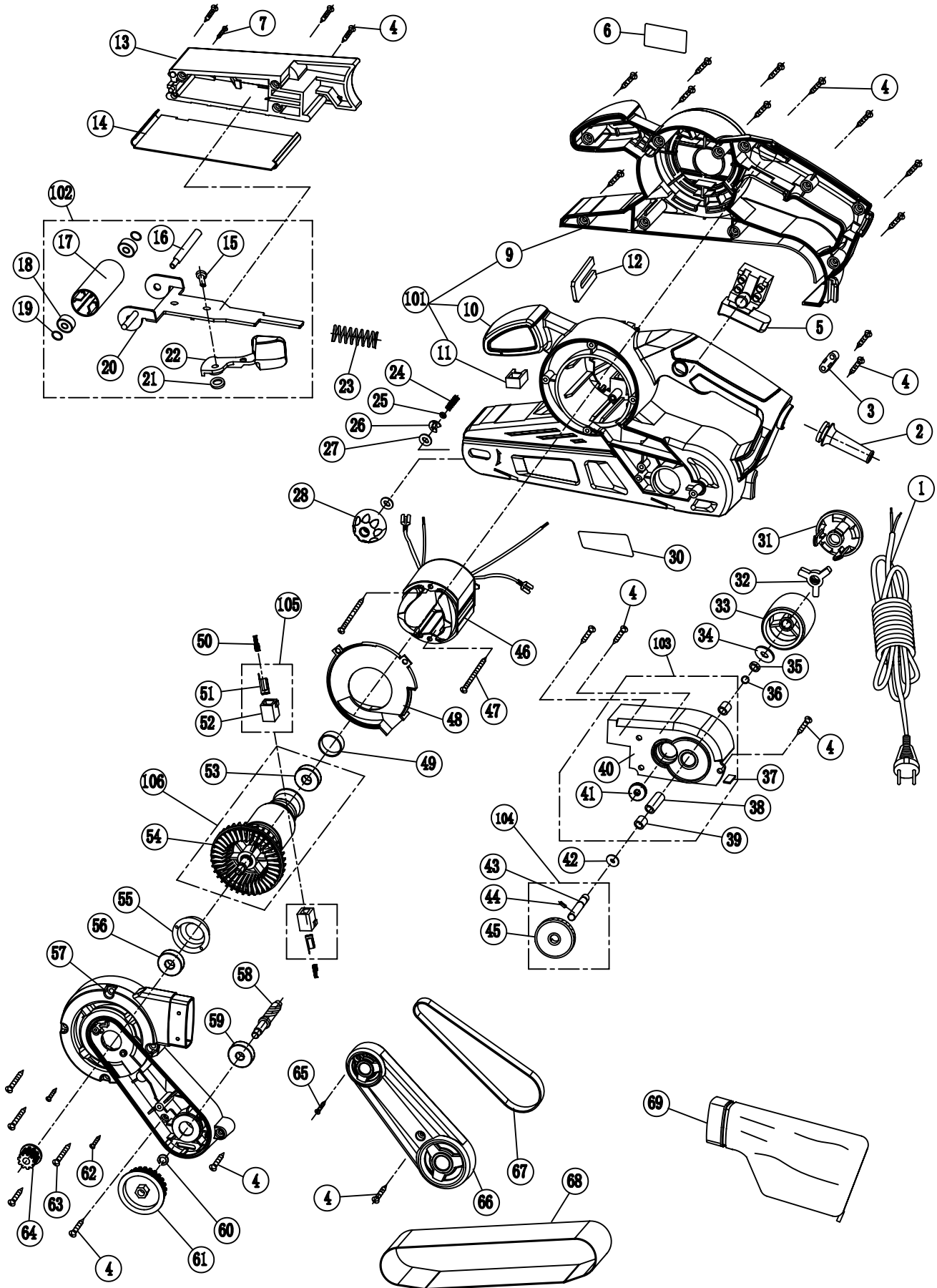

EXPLODED VIEW & PARTS LIST

No.	Part No.	Description	Qty.
1	6321-001	Power Cord	1
2	6321-002	Cord Protector	1
3	6321-003	Cord Clamp	1
4	6321-004	Screws	21
5	6321-005	Switch	1
6	6321-006	Label	1
7	6321-007	Screws	1
9	6321-009	Right Housing	1
10	6321-010	Centra Housing	1
11	6321-011	Ceramic Plate	1
12	6321-012	Support Block	1
13	6321-013	Clamp Device	1
14	6321-014	Base Plate	1
15	6321-015	Rivet 6	1
16	6321-016	Pin	1
17	6321-017	Roller	1
18	6321-018	Bearing 626-2Z	2
19	6321-019	Adjustment Washer	2
20	6321-020	Fork	1
21	6321-021	Washer 6	1
22	6321-022	Spanner	1
23	6321-023	Big Spring	1
24	6321-024	Support Spring	1
25	6321-025	Retaining Ring	1
26	6321-026	Washer 7	1
27	6321-027	Washer 8	2
28	6321-028	Adjustment Knob	1
30	6321-030	Name Plate	1
31	6321-031	Rear Roller Cover	1
32	6321-032	Nut	1
33	6321-033	Drum Roller	1
34	6321-034	Washer	1
35	6321-035	Washer	1
36	6321-036	Snap Ring 8	1
37	6321-037	Ceramic Plate	1
38	6321-038	Locate Sleeve	1
39	6321-039	Needle Bearing	2

No.	Part No.	Description	Qty.
40	6321-040	Aluminium Support	1
41	6321-041	Bearing 626-Z	1
42	6321-042	Adjustment Washer	1
43	6321-043	Driven Shaft	1
44	6321-044	Pin 3	1
45	6321-045	Big Gear	1
46	6321-046	Stator Assembly	1
47	6321-047	Screws	2
48	6321-048	Fan Baffle	1
49	6321-049	Washer	1
50	6321-050	Carbon Brush	2
51	6321-051	Brush Holder	2
52	6321-052	Brush Support	2
53	6321-053	Bearing 626-2Z	1
54	6321-054	Rotor	1
55	6321-055	Bearing Cover	1
56	6321-056	Bearing 608-2RS	1
57	6321-057	Left Housing	1
58	6321-058	Pinion Shaft Gear	1
59	6321-059	Bearing 627-2Z	1
60	6321-060	Washer 7	1
61	6321-061	Big Driving Gear	1
62	6321-062	Screws	2
63	6321-063	Screws	4
64	6321-064	Small Pulley	1
65	6321-065	Screws	1
66	6321-066	Belt Cover	1
67	6321-067	Drive Belt	1
68	6321-068	Sandpaper	1
69	6321-069	Dust Bag	1
101	6321-101	Housing Assembly	1
102	6321-102	Fork Assembly	1
103	6321-103	Support Assembly	1
104	6321-104	Shaft Assembly	1
105	6321-105	Brush Assembly	2
106	6321-106	Rotor Assembly	1

WARRANTY STATEMENT

WEN Products is committed to building tools that are dependable for years. Our warranties are consistent with this commitment and our dedication to quality.

LIMITED WARRANTY OF WEN PRODUCTS FOR HOME USE

GREAT LAKES TECHNOLOGIES, LLC (“Seller”) warrants to the original purchaser only, that all WEN consumer power tools will be free from defects in material or workmanship during personal use for a period of two (2) years from date of purchase or 500 hours of use; whichever comes first. Ninety days for all WEN products if the tool is used for professional or commercial use. Purchaser has 30 days from the date of purchase to report missing or damaged parts.

SELLER’S SOLE OBLIGATION AND YOUR EXCLUSIVE REMEDY under this Limited Warranty and, to the extent permitted by law, any warranty or condition implied by law, shall be the replacement of parts, without charge, which are defective in material or workmanship and which have not been subjected to misuse, alteration, careless handling, misrepair, abuse, neglect, normal wear and tear, improper maintenance, or other conditions adversely affecting the Product or the component of the Product, whether by accident or intentionally, by persons other than Seller. To make a claim under this Limited Warranty, you must make sure to keep a copy of your proof of purchase that clearly defines the Date of Purchase (month and year) and the Place of Purchase. Place of Purchase must be a direct vendor of Great Lakes Technologies, LLC. Purchasing through third party vendors, including but not limited to garage sales, pawn shops, resale shops, or any other secondhand merchant, voids the warranty included with this product. Contact techsupport@wenproducts.com or 1-847-429-9263 with the following information to make arrangements: your shipping address, phone number, serial number, required part numbers, and proof of purchase. Damaged or defective parts and products may need to be sent to WEN before the replacements can be shipped out.

Upon the confirmation of a WEN representative, your product may qualify for repairs and service work. When returning a product for warranty service, the shipping charges must be prepaid by the purchaser. The product must be shipped in its original container (or an equivalent), properly packed to withstand the hazards of shipment. The product must be fully insured with a copy of the proof of purchase enclosed. There must also be a description of the problem in order to help our repairs department diagnose and fix the issue. Repairs will be made and the product will be returned and shipped back to the purchaser at no charge for addresses within the contiguous United States.

THIS LIMITED WARRANTY DOES NOT APPLY TO ITEMS THAT WEAR OUT FROM REGULAR USAGE OVER TIME, INCLUDING BELTS, BRUSHES, BLADES, BATTERIES, ETC. ANY IMPLIED WARRANTIES SHALL BE LIMITED IN DURATION TO TWO (2) YEARS FROM DATE OF PURCHASE. SOME STATES IN THE U.S. AND SOME CANADIAN PROVINCES DO NOT ALLOW LIMITATIONS ON HOW LONG AN IMPLIED WARRANTY LASTS, SO THE ABOVE LIMITATION MAY NOT APPLY TO YOU.

IN NO EVENT SHALL SELLER BE LIABLE FOR ANY INCIDENTAL OR CONSEQUENTIAL DAMAGES (INCLUDING BUT NOT LIMITED TO LIABILITY FOR LOSS OF PROFITS) ARISING FROM THE SALE OR USE OF THIS PRODUCT. SOME STATES IN THE U.S. AND SOME CANADIAN PROVINCES DO NOT ALLOW THE EXCLUSION OR LIMITATION OF INCIDENTAL OR CONSEQUENTIAL DAMAGES, SO THE ABOVE LIMITATION OR EXCLUSION MAY NOT APPLY TO YOU.

THIS LIMITED WARRANTY GIVES YOU SPECIFIC LEGAL RIGHTS, AND YOU MAY ALSO HAVE OTHER RIGHTS WHICH VARY FROM STATE TO STATE IN THE U.S., PROVINCE TO PROVINCE IN CANADA AND FROM COUNTRY TO COUNTRY.

THIS LIMITED WARRANTY APPLIES ONLY TO ITEMS SOLD WITHIN THE UNITED STATES OF AMERICA, CANADA AND THE COMMONWEALTH OF PUERTO RICO. FOR WARRANTY COVERAGE WITHIN OTHER COUNTRIES, CONTACT THE WEN CUSTOMER SUPPORT LINE. FOR WARRANTY PARTS OR PRODUCTS REPAIRED UNDER WARRANTY SHIPPING TO ADDRESSES OUTSIDE OF THE CONTIGUOUS UNITED STATES, ADDITIONAL SHIPPING CHARGES MAY APPLY.

**THANKS FOR
REMEMBERING**  [®]