

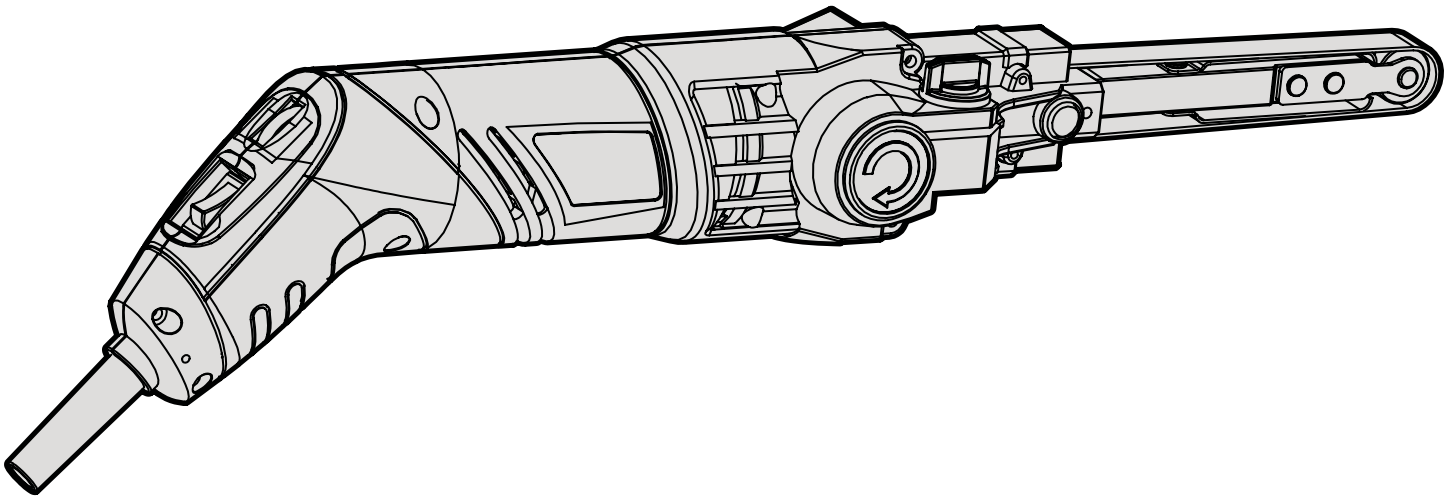

MODEL 6307

1/2" x 18" VARIABLE SPEED FILE SANDER

Instruction Manual



NEED HELP? CONTACT US!

Have product questions? Need technical support? Please feel free to contact us:



1-847-429-9263 (M-F 8AM-5PM CST)



TECHSUPPORT@WENPRODUCTS.COM

IMPORTANT: Your new tool has been engineered and manufactured to WEN's highest standards for dependability, ease of operation, and operator safety. When properly cared for, this product will supply you years of rugged, trouble-free performance. Pay close attention to the rules for safe operation, warnings, and cautions. If you use your tool properly and for its intended purpose, you will enjoy years of safe, reliable service.

For replacement parts and the most up-to-date instruction manuals, visit ***WENPRODUCTS.COM***

CONTENTS

WELCOME	3
Introduction	3
Specifications.....	3
SAFETY	4
General Safety Rules	4
File Sander Safety Warnings	6
Electrical Information.....	8
BEFORE OPERATING	9
Unpacking & Packing List.....	9
Know Your File Sander.....	9
Assembly & Adjustments.....	10
OPERATION & MAINTENANCE	11
Operation	11
Maintenance.....	11
Exploded View & Parts List.....	12
Warranty Statement.....	14

To purchase accessories and replacement parts for your tool, visit ***WENPRODUCTS.COM***

80-Grit Sanding Belt Sandpaper, 10 Pack (Model 6307SP80)

120-Grit Sanding Belt Sandpaper, 10 Pack (Model 6307SP120)

320-Grit Sanding Belt Sandpaper, 10 Pack (Model 6307SP320)

INTRODUCTION

Thanks for purchasing the WEN File Sander. We know you are excited to put your tool to work, but first, please take a moment to read through the manual. Safe operation of this tool requires that you read and understand this operator's manual and all the labels affixed to the tool. This manual provides information regarding potential safety concerns, as well as helpful assembly and operating instructions for your tool.

 **SAFETY ALERT SYMBOL:** Indicates danger, warning, or caution. The safety symbols and the explanations with them deserve your careful attention and understanding. Always follow the safety precautions to reduce the risk of fire, electric shock or personal injury. However, please note that these instructions and warnings are not substitutes for proper accident prevention measures.

NOTE: The following safety information is not meant to cover all possible conditions and situations that may occur. WEN reserves the right to change this product and specifications at any time without prior notice.

At WEN, we are continuously improving our products. If you find that your tool does not exactly match this manual, please visit wenproducts.com for the most up-to-date manual or contact our customer service at **1-847-429-9263**.

Keep this manual available to all users during the entire life of the tool and review it frequently to maximize safety for both yourself and others.

SPECIFICATIONS

Model Number	6307
Motor	120V, 60 Hz, 2A
Speed	1,100 to 1,800 FPM
Belt Size	1/2 in. x 18 in.
Range of Motion	50 Degrees
Product Weight	2.4 Pounds
Product Dimensions	17.5 in. x 3.5 in. x 3.5 in.

GENERAL SAFETY RULES

 **WARNING!** Read all safety warnings and all instructions. Failure to follow the warnings and instructions may result in electric shock, fire and/or serious injury.

Safety is a combination of common sense, staying alert and knowing how your item works. The term “power tool” in the warnings refers to your mains-operated (corded) power tool or battery-operated (cordless) power tool.

SAVE THESE SAFETY INSTRUCTIONS.

WORK AREA SAFETY

- 1. Keep work area clean and well lit.** Cluttered or dark areas invite accidents.
- 2. Do not operate power tools in explosive atmospheres, such as in the presence of flammable liquids, gases or dust.** Power tools create sparks which may ignite the dust or fumes.
- 3. Keep children and bystanders away while operating a power tool.** Distractions can cause you to lose control.

ELECTRICAL SAFETY

- 1. Power tool plugs must match the outlet. Never modify the plug in any way. Do not use any adapter plugs with earthed (grounded) power tools.** Unmodified plugs and matching outlets will reduce risk of electric shock.
- 2. Avoid body contact with earthed or grounded surfaces such as pipes, radiators, ranges and refrigerators.** There is an increased risk of electric shock if your body is earthed or grounded.
- 3. Do not expose power tools to rain or wet conditions.** Water entering a power tool will increase the risk of electric shock.
- 4. Do not abuse the cord. Never use the cord for carrying, pulling or unplugging the power tool. Keep cord away from heat, oil, sharp edges or moving parts.** Damaged or entangled cords increase the risk of electric shock.
- 5. When operating a power tool outdoors, use an extension cord suitable for outdoor use.** Use of a cord suitable for outdoor use reduces the risk of electric shock.

6. If operating a power tool in a damp location is unavoidable, use a ground fault circuit interrupter (GFCI) protected supply. Use of a GFCI reduces the risk of electric shock.

PERSONAL SAFETY

- 1. Stay alert, watch what you are doing and use common sense when operating a power tool. Do not use a power tool while you are tired or under the influence of drugs, alcohol or medication.** A moment of inattention while operating power tools may result in serious personal injury.
- 2. Use personal protective equipment. Always wear eye protection.** Protective equipment such as a respiratory mask, non-skid safety shoes and hearing protection used for appropriate conditions will reduce the risk of personal injury.
- 3. Prevent unintentional starting. Ensure the switch is in the off-position before connecting to power source and/or battery pack, picking up or carrying the tool.** Carrying power tools with your finger on the switch or energizing power tools that have the switch on invites accidents.
- 4. Remove any adjusting key or wrench before turning the power tool on.** A wrench or a key left attached to a rotating part of the power tool may result in personal injury.
- 5. Do not overreach. Keep proper footing and balance at all times.** This enables better control of the power tool in unexpected situations.
- 6. Dress properly. Do not wear loose clothing or jewelry. Keep your hair and clothing away from moving parts.** Loose clothes, jewelry or long hair can be caught in moving parts.

GENERAL SAFETY RULES

 **WARNING!** Read all safety warnings and all instructions. Failure to follow the warnings and instructions may result in electric shock, fire and/or serious injury.

Safety is a combination of common sense, staying alert and knowing how your item works. The term “power tool” in the warnings refers to your mains-operated (corded) power tool or battery-operated (cordless) power tool.

SAVE THESE SAFETY INSTRUCTIONS.

7. If devices are provided for the connection of dust extraction and collection facilities, ensure these are connected and properly used. Use of dust collection can reduce dust-related hazards.

POWER TOOL USE AND CARE

1. Do not force the power tool. Use the correct power tool for your application. The correct power tool will do the job better and safer at the rate for which it was designed.

2. Do not use the power tool if the switch does not turn it on and off. Any power tool that cannot be controlled with the switch is dangerous and must be repaired.

3. Disconnect the plug from the power source and/or the battery pack from the power tool before making any adjustments, changing accessories, or storing power tools. Such preventive safety measures reduce the risk of starting the power tool accidentally.

4. Store idle power tools out of the reach of children and do not allow persons unfamiliar with the power tool or these instructions to operate the power tool. Power tools are dangerous in the hands of untrained users.

5. Maintain power tools. Check for misalignment or binding of moving parts, breakage of parts and any other condition that may affect the power tool's operation. If damaged, have the power tool repaired before use. Many accidents are caused by poorly maintained power tools.

6. Keep cutting tools sharp and clean. Properly maintained cutting tools with sharp cutting edges are less likely to bind and are easier to control.

7. Use the power tool, accessories and tool bits, etc. in accordance with these instructions, taking into account the working conditions and the work to be performed. Use of the power tool for operations different from those intended could result in a hazardous situation.

8. Use clamps to secure your workpiece to a stable surface. Holding a workpiece by hand or using your body to support it may lead to loss of control.

9. KEEP GUARDS IN PLACE and in working order.

SERVICE

1. Have your power tool serviced by a qualified repair person using only identical replacement parts. This will ensure that the safety of the power tool is maintained.

CALIFORNIA PROPOSITION 65 WARNING

Some dust created by power sanding, sawing, grinding, drilling, and other construction activities may contain chemicals, including lead, known to the State of California to cause cancer, birth defects, or other reproductive harm. Wash hands after handling. Some examples of these chemicals are:

- Lead from lead-based paints.
- Crystalline silica from bricks, cement, and other masonry products.
- Arsenic and chromium from chemically treated lumber.

Your risk from these exposures varies depending on how often you do this type of work. To reduce your exposure to these chemicals, work in a well-ventilated area with approved safety equipment such as dust masks specially designed to filter out microscopic particles.

FILE SANDER SAFETY WARNINGS

⚠ WARNING! Do not operate the power tool until you have read and understood the following instructions and the warning labels.

⚠ WARNING! EXTREME CAUTION REQUIRED WHEN SANDING PAINT. The dust residue may contain LEAD which is poisonous. Exposure to even low levels of lead can cause irreversible brain and nervous system damage, to which young and unborn children are particularly vulnerable. Any pre-1960s building may have paint containing lead on wood or metal surfaces that has since been covered with additional layers of paint. Lead based paints should only be removed by a professional and should not be removed using a sander. If you suspect that paint on surfaces contains lead please seek professional advice.

⚠ WARNING! Use a face mask and dust collection. Some wood and wood type products such as MDF (Medium Density Fiberboard) can produce dust that can be hazardous to your health. We recommend the use of a dust extraction system and an approved face mask with replaceable filters when using this machine.

FILE SANDER SAFETY

1. MAINTAINING A STABLE STANCE

Ensure proper balance when using the tool. Do not stand on ladders and step ladders during operation. If the machine is to be used on a higher and otherwise unreachable surface, a suitable and stable platform or scaffold tower with hand rails and kick boards should be used.

2. PREPARING THE WORKPIECE

Check the workpiece for any protruding nails, screw heads or anything else that could tear or damage the belt.

3. SECURING THE WORKPIECE

Never hold the workpiece in your hand or across your legs. Small workpieces must be adequately secured so that the rotating belt doesn't pick them up during the forward motion of the sander. Unstable support causes the belt to bind, resulting in a loss of control and possible injury.

4. CHECKING THE POWERCORD

Make sure that the power cord is prevented from coming into contact with the machine or getting caught up on other objects preventing completion of the sanding pass.

5. HOLDING THE SANDER

Keep handles and hands dry, clean and free from oil and grease. Hold the power tool by the insulated gripping surfaces only in case the belt contacts its own cord. Cutting a "live" wire may make exposed metal parts of the tool "live" and could give the operator an electric shock.

6. SAND ON DRY SURFACES ONLY

This machine is to be used for dry sanding only. Do not attempt to use for wet sanding operations, as fatal electric shock may occur.

7. STARTING THE SANDER

Always start the sander before the sanding belt is in contact with the workpiece. Let the sander reach full speed before using the tool. Do not start the machine whilst it is in contact with the workpiece.

8. SANDING THE WORKPIECE

Caution: when the machine contacts the workpiece it will have a tendency to grab and pull forward. Resist the forward motion and keep the belt sander moving at an even pace. Never pull the tool backwards over the workpiece. Sand in the direction of the grain whenever possible. Remove the sanding dust between each grade of sanding sheet. Never leave the machine unattended while it is still running.

9. SETTING DOWN THE SANDER

Wait for the belt to stop before setting the tool down. An exposed rotating belt may engage the surface, leading to possible loss of control and serious injury. Always lay the sander on its side to prevent accidents if the machine is inadvertently started.

FILE SANDER SAFETY WARNINGS

 **WARNING!** Do not operate the power tool until you have read and understood the following instructions and the warning labels.

10. UNPLUG YOUR SANDER

Ensure that the sander is disconnected from the main supply before servicing, lubricating, making adjustments, changing accessories, or replacing sanding belts. Accidental start-ups may occur if the tool is plugged in during an accessory change. Before plugging the tool back in, check that the trigger is OFF.

11. REPLACING THE SANDING BELT

Replace the sanding belt as soon as it becomes worn or torn. Torn sanding belts can cause deep scratches that are difficult to remove. Ensure that the sanding belt is the correct size for the machine. After changing a sanding belt, rotate the belt to make sure it doesn't hit any part of the tool.

12. CLEANING YOUR SANDER

Clean and maintain your tool periodically. When cleaning a tool, be careful not to disassemble any portion of the tool. Internal wires may be misplaced or pinched and safety guard return springs may be improperly mounted. Certain cleaning agents such as gasoline, carbon tetrachloride, ammonia, etc. may damage plastic parts.

ELECTRICAL INFORMATION

GROUNDING INSTRUCTIONS

In the event of a malfunction or breakdown, grounding provides the path of least resistance for an electric current and reduces the risk of electric shock. This tool is equipped with an electric cord that has an equipment grounding conductor and a grounding plug. The plug **MUST** be plugged into a matching outlet that is properly installed and grounded in accordance with ALL local codes and ordinances.

1. Do not modify the plug provided. If it will not fit the outlet, have the proper outlet installed by a licensed electrician.

2. Improper connection of the equipment grounding conductor can result in electric shock. The conductor with the green insulation (with or without yellow stripes) is the equipment grounding conductor. If repair or replacement of the electric cord or plug is necessary, **DO NOT** connect the equipment grounding conductor to a live terminal.

3. Check with a licensed electrician or service personnel if you do not completely understand the grounding instructions or whether the tool is properly grounded.

4. Use only three-wire extension cords that have three-pronged plugs and outlets that accept the tool's plug. Repair or replace a damaged or worn cord immediately.

CAUTION! In all cases, make certain the outlet in question is properly grounded. If you are not sure, have a licensed electrician check the outlet.

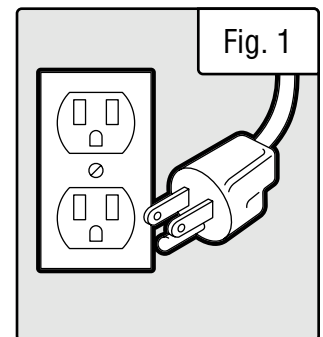

GUIDELINES AND RECOMMENDATIONS FOR EXTENSION CORDS

When using an extension cord, be sure to use one heavy enough to carry the current your product will draw. An undersized cord will cause a drop in line voltage resulting in loss of power and overheating. The table below shows the correct size to be used according to cord length and ampere rating. When in doubt, use a heavier cord. The smaller the gauge number, the heavier the cord.

AMPERAGE	REQUIRED GAUGE FOR EXTENSION CORDS			
	25 ft.	50 ft.	100 ft.	150 ft.
2A	18 gauge	16 gauge	16 gauge	14 gauge

1. Examine extension cord before use. Make sure your extension cord is properly wired and in good condition. Always replace a damaged extension cord or have it repaired by a qualified person before using it.

2. Do not abuse extension cord. Do not pull on cord to disconnect from receptacle; always disconnect by pulling on plug. Disconnect the extension cord from the receptacle before disconnecting the product from the extension cord. Protect your extension cords from sharp objects, excessive heat and damp/wet areas.

3. Use a separate electrical circuit for your tool. This circuit must not be less than a 12-gauge wire and should be protected with a 15A time-delayed fuse. Before connecting the motor to the power line, make sure the switch is in the OFF position and the electric current is rated the same as the current stamped on the motor nameplate. Running at a lower voltage will damage the motor.

UNPACKING & PACKING LIST

UNPACKING

Carefully remove the file sander from the packaging and place it on a sturdy, flat surface. Make sure to take out all contents and accessories. Do not discard the packaging until everything is removed. Check the packing list below to make sure you have all of the parts and accessories. If any part is missing or broken, please contact customer service at **1-847-429-9263** (M-F 8-5 CST), or email techsupport@wenproducts.com.

PACKING LIST

Description	Qty.
File Sander	1
*80-Grit Sanding Belt	1
120-Grit Sanding Belt	1
320-Grit Sanding Belt	1

* Pre-Installed

KNOW YOUR FILE SANDER

Use the diagram below to become familiarized with the components and controls of your file sander. If you have any questions or concerns, please contact our customer service at **1-847-429-9263** (M-F 8-5 CST), or email techsupport@wenproducts.com.

Front Roller

Sanding Belt

Angle Locking Screw

Handle

Variable Speed Dial

Power Switch

Arm

Belt Tensioning Lever

Belt Direction Indicator

Dust Chute Extraction Port

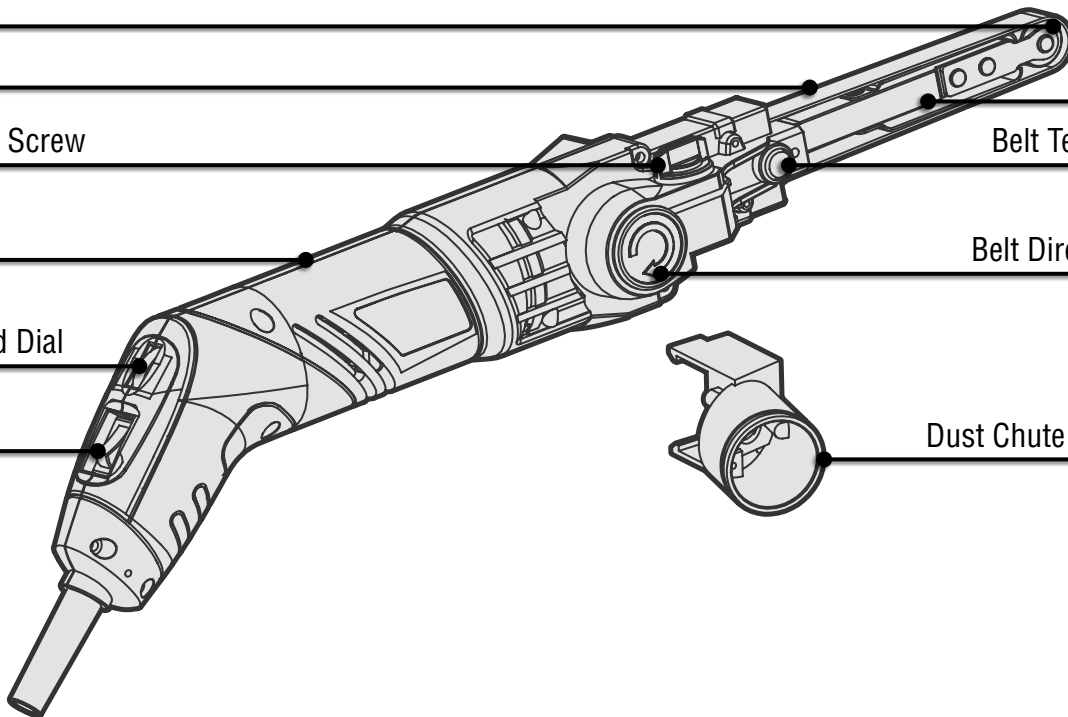

ASSEMBLY & ADJUSTMENTS

⚠ WARNING! Do not plug in or turn on the tool until it is fully assembled according to the instructions. Failure to follow the safety instructions may result in serious personal injury.

CHOOSING SANDING BELTS

This item includes three sanding belts, one 80-grit sanding belt (fitted on the tool), one 120-grit sanding belt, and one 320-grit sanding belt. Sanding belts come in different grades for different applications. Refer to the table below for the type and applications of different grades.

GRIT	TYPE	APPLICATIONS
Up to 60	Very Coarse	Rough work, removing hard paint, shaping wood
80 to 100	Course	Removing paint, smoothing rough surfaces (e.g. unplanned wood)
120 - 150	Medium Course	Smoothing planed wood
180 to 220	Fine	Sanding between coats of paint
240 or Higher	Very Fine	Finishing off

INSTALLING THE SANDING BELT

1. Press the tip of the sander against a hard object to retract the front roller (Fig. 2 - 1).
2. Insert the sanding belt on the rollers. Check that the arrow on the inside of the sanding belt points in the same direction as the arrow indicated on the tool (Fig. 3 - 1).
3. Press the belt tensioning lever (Fig. 4 - 1) to tension the sanding belt.

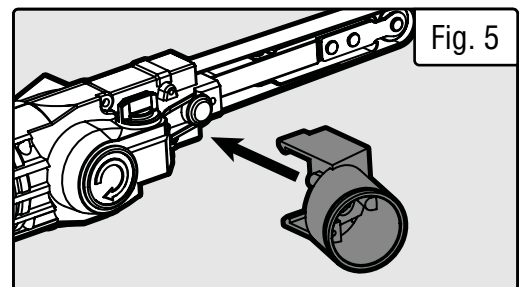
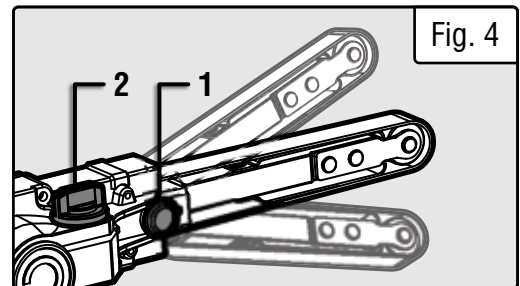
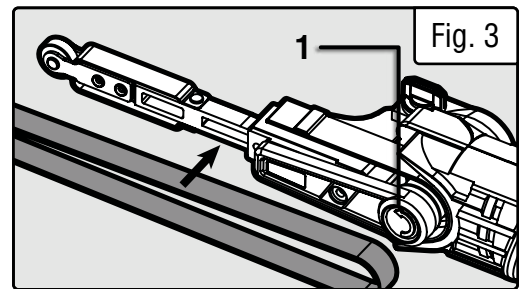
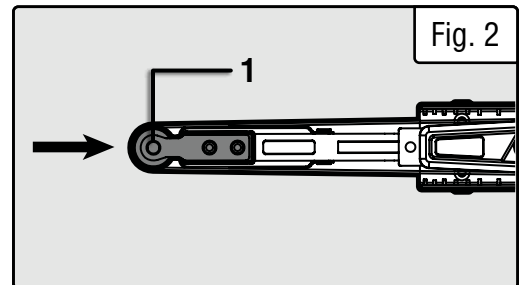

⚠ WARNING! Do not use worn, damaged or clogged sanding belts. Do not use the same sanding belt for metal and wood. Metal particles embedded in the sanding belt will damage the surface of the wood.

ADJUSTING THE ARM ANGLE

1. Loosen the angle locking screw (Fig. 4 - 2) by turning it counterclockwise.
2. Move the arm to the required angle.
3. Tighten the screw (clockwise) to lock the arm in place.

USING DUST EXTRACTION

We recommend that you always use a dust extractor and an approved face mask during sanding operations.

1. Match the groove on the dust extractor port (Fig. 5 - 1) with that on the sander and attach the dust extractor port on the tool. Check that it is securely installed.
2. Connect a dust extractor hose or dust bag with an inner diameter of 1-1/4 inches (32 mm) to the dust extractor port.

OPERATION

The tool is intended for sanding flat exterior and interior surfaces, rounding corners and edges, deburring, removing paint, welding spatter and rust, and for sharpening knives and scissors etc. All other applications are considered to be unsuitable. Only use tool for its intended purpose.

⚠ CAUTION! Never cover air vents. They must always be open for proper motor cooling. Make sure that the workpiece is free of foreign objects that could tear the abrasive belt.

1. Turn the power switch (Fig. 6 - 1) ON and allow the motor to reach full speed.

2. Adjust the sanding belt speed by turning the variable speed dial (Fig. 6 - 2) to the required speed. Do this before contacting the work surface to avoid varied finishes on the final project.

3. Gently bring belt into contact with the surface. **CAUTION!** The sander may initially snatch forwards. Resist the forward motion and keep the belt sander moving at an even pace.

NOTE: Always lift the tool off the workpiece before starting/stopping the tool.

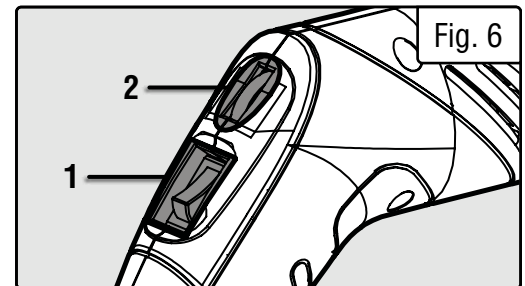

⚠ CAUTION! If the sander makes an unfamiliar sound or vibrates excessively switch it off immediately and disconnect from the power supply. Investigate the cause or consult the service center for advice.

MAINTENANCE

SERVICE: Preventive maintenance performed by unauthorized personnel may result in misplacing of internal wires and components, possibly causing a serious hazard. We recommend that all tool service be performed by an authorized WEN service station.

CLEANING: Ventilation openings and switch levers must be kept clean and free of foreign matter. The tool may be cleaned most effectively with compressed dry air. Do not attempt to clean these components by inserting pointed objects through openings.

Certain cleaning agents and solvents damage plastic parts. Some of these are: gasoline, carbon tetrachloride, chlorinated cleaning solvents, ammonia and household detergents that contain ammonia.

⚠ WARNING! To avoid injury from accidental startups, switch off the tool and unplug the power cord before adjusting, replacing accessories, cleaning or maintenance.

PRODUCT DISPOSAL: In order to minimize adverse environmental impact, please do not dispose of the tool in household waste. Take it to your local waste recycling center or an authorized collection and disposal facility. If in doubt consult your local waste authority for information regarding available recycling and/or disposal options.

EXPLODED VIEW & PARTS LIST

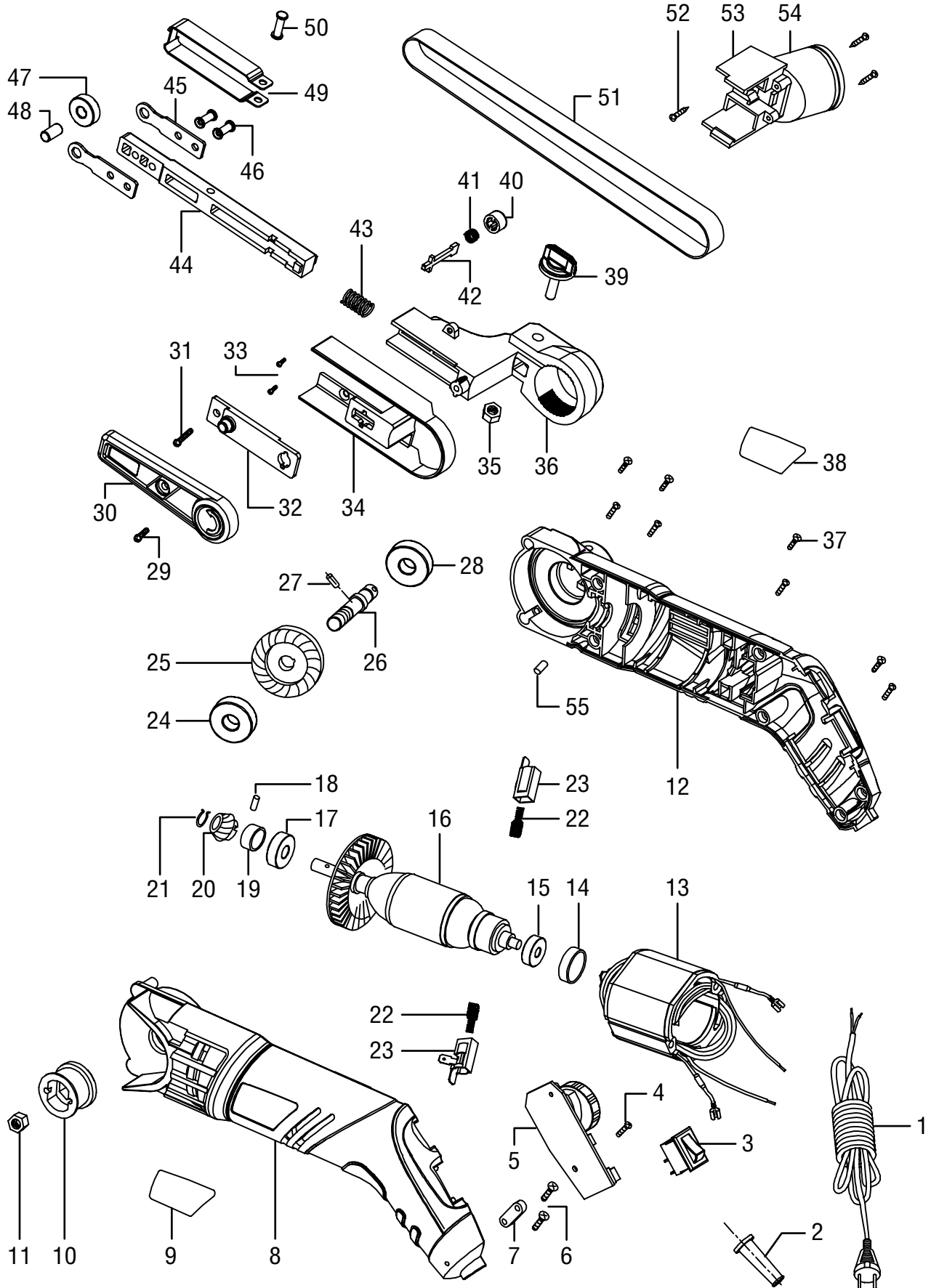

EXPLODED VIEW & PARTS LIST

NOTE: Replacement parts can be purchased from wenproducts.com, or by calling our customer service at **1-847-429-9263**, M-F 8-5 CST. Parts and accessories that wear down over the course of normal use are not covered by the two-year warranty. Not all parts may be available for purchase.

No	Part Number	Description	Qty.
1	6307-001	Power Cord	1
2	6307-002	Power Cord Sleeve	1
3	6307-003	Switch	1
4	6307-004	Screw	1
5	6307-005	PCB Board	1
6	6307-006	Screw	2
7	6307-007	Cord Clamp	1
8	6307-008	Left Housing	1
9	6307-009	Label	1
10	6307-010	Drum	1
11	6307-011	Nut	1
12	6307-008	Right Housing	1
13	6307-013	Stator	1
14	6307-014	Bearing Washer 626-2RS	1
15	6307-101	Bearing 626-2RS	1
16		Rotor	1
17	6307-017	Bearing 626-2RS	1
18	6307-018	Pin	1
19	6307-019	Sleeve	1
20	6307-020	Gear	1
21	6307-021	Retaining Ring	1
22	6307-022	Carbon Brush	2
23	6307-023	Brush Holder	2
24	6307-102	Bearing 608-2RS	1
25		Gear	1
26		Shaft	1
27		Pin	1
28		Bearing 608-2RS	1
29	6307-029	Screw	1
30	6307-030	Belt Cover	1
31	6307-031	Screw	1

No	Part Number	Description	Qty.
32	6307-032	Belt Plate	1
33	6307-033	Screw	2
34	6307-034	Belt Housing	1
35	6307-035	Nut	1
36	6307-036	Arm Support	1
37	6307-037	Screw	8
38	6307-038	Label	1
39	6307-039	Adjustment Knob	1
40	6307-103	Button	1
41		Spring	1
42		Lock	1
43	6307-043	Spring	1
44	6307-104	Arm	1
45		Support Plate	2
46		Rivet	2
47		Bearing 608-2RS	1
48		Pin	1
49		Base Plate	1
50		Rivet	1
51	6307SP	Sanding Belt	1
52	6307-105	Screw	3
53		Dust Port Clip	1
54		Dust Port Sleeve	1
55	6307-055	Rubber Insert	1
101	6307-101	Rotor Assembly	1
102	6307-102	Gear Assembly	1
103	6307-103	Button Assembly	1
104	6307-104	Belt Support Assembly	1
105	6307-105	Dust Port Assembly	1

NOTE: Not all parts may be available for purchase. Parts and accessories that wear down over the course of normal use are not covered under the warranty.

WARRANTY STATEMENT

WEN Products is committed to building tools that are dependable for years. Our warranties are consistent with this commitment and our dedication to quality.

LIMITED WARRANTY OF WEN PRODUCTS FOR HOME USE

GREAT LAKES TECHNOLOGIES, LLC (“Seller”) warrants to the original purchaser only, that all WEN consumer power tools will be free from defects in material or workmanship during personal use for a period of two (2) years from date of purchase or 500 hours of use; whichever comes first. Ninety days for all WEN products if the tool is used for professional or commercial use. Purchaser has 30 days from the date of purchase to report missing or damaged parts.

SELLER’S SOLE OBLIGATION AND YOUR EXCLUSIVE REMEDY under this Limited Warranty and, to the extent permitted by law, any warranty or condition implied by law, shall be the replacement of parts, without charge, which are defective in material or workmanship and which have not been subjected to misuse, alteration, careless handling, misrepair, abuse, neglect, normal wear and tear, improper maintenance, or other conditions adversely affecting the Product or the component of the Product, whether by accident or intentionally, by persons other than Seller. To make a claim under this Limited Warranty, you must make sure to keep a copy of your proof of purchase that clearly defines the Date of Purchase (month and year) and the Place of Purchase. Place of Purchase must be a direct vendor of Great Lakes Technologies, LLC. Purchasing through third party vendors, including but not limited to garage sales, pawn shops, resale shops, or any other secondhand merchant, voids the warranty included with this product. Contact techsupport@wenproducts.com or 1-847-429-9263 with the following information to make arrangements: your shipping address, phone number, serial number, required part numbers, and proof of purchase. Damaged or defective parts and products may need to be sent to WEN before the replacements can be shipped out.

Upon the confirmation of a WEN representative, your product may qualify for repairs and service work. When returning a product for warranty service, the shipping charges must be prepaid by the purchaser. The product must be shipped in its original container (or an equivalent), properly packed to withstand the hazards of shipment. The product must be fully insured with a copy of the proof of purchase enclosed. There must also be a description of the problem in order to help our repairs department diagnose and fix the issue. Repairs will be made and the product will be returned and shipped back to the purchaser at no charge for addresses within the contiguous United States.

THIS LIMITED WARRANTY DOES NOT APPLY TO ITEMS THAT WEAR OUT FROM REGULAR USAGE OVER TIME, INCLUDING BELTS, BRUSHES, BLADES, BATTERIES, ETC. ANY IMPLIED WARRANTIES SHALL BE LIMITED IN DURATION TO TWO (2) YEARS FROM DATE OF PURCHASE. SOME STATES IN THE U.S. AND SOME CANADIAN PROVINCES DO NOT ALLOW LIMITATIONS ON HOW LONG AN IMPLIED WARRANTY LASTS, SO THE ABOVE LIMITATION MAY NOT APPLY TO YOU.

IN NO EVENT SHALL SELLER BE LIABLE FOR ANY INCIDENTAL OR CONSEQUENTIAL DAMAGES (INCLUDING BUT NOT LIMITED TO LIABILITY FOR LOSS OF PROFITS) ARISING FROM THE SALE OR USE OF THIS PRODUCT. SOME STATES IN THE U.S. AND SOME CANADIAN PROVINCES DO NOT ALLOW THE EXCLUSION OR LIMITATION OF INCIDENTAL OR CONSEQUENTIAL DAMAGES, SO THE ABOVE LIMITATION OR EXCLUSION MAY NOT APPLY TO YOU.

THIS LIMITED WARRANTY GIVES YOU SPECIFIC LEGAL RIGHTS, AND YOU MAY ALSO HAVE OTHER RIGHTS WHICH VARY FROM STATE TO STATE IN THE U.S., PROVINCE TO PROVINCE IN CANADA AND FROM COUNTRY TO COUNTRY.

THIS LIMITED WARRANTY APPLIES ONLY TO ITEMS SOLD WITHIN THE UNITED STATES OF AMERICA, CANADA AND THE COMMONWEALTH OF PUERTO RICO. FOR WARRANTY COVERAGE WITHIN OTHER COUNTRIES, CONTACT THE WEN CUSTOMER SUPPORT LINE. FOR WARRANTY PARTS OR PRODUCTS REPAIRED UNDER WARRANTY SHIPPING TO ADDRESSES OUTSIDE OF THE CONTIGUOUS UNITED STATES, ADDITIONAL SHIPPING CHARGES MAY APPLY.

**THANKS FOR
REMEMBERING**

