

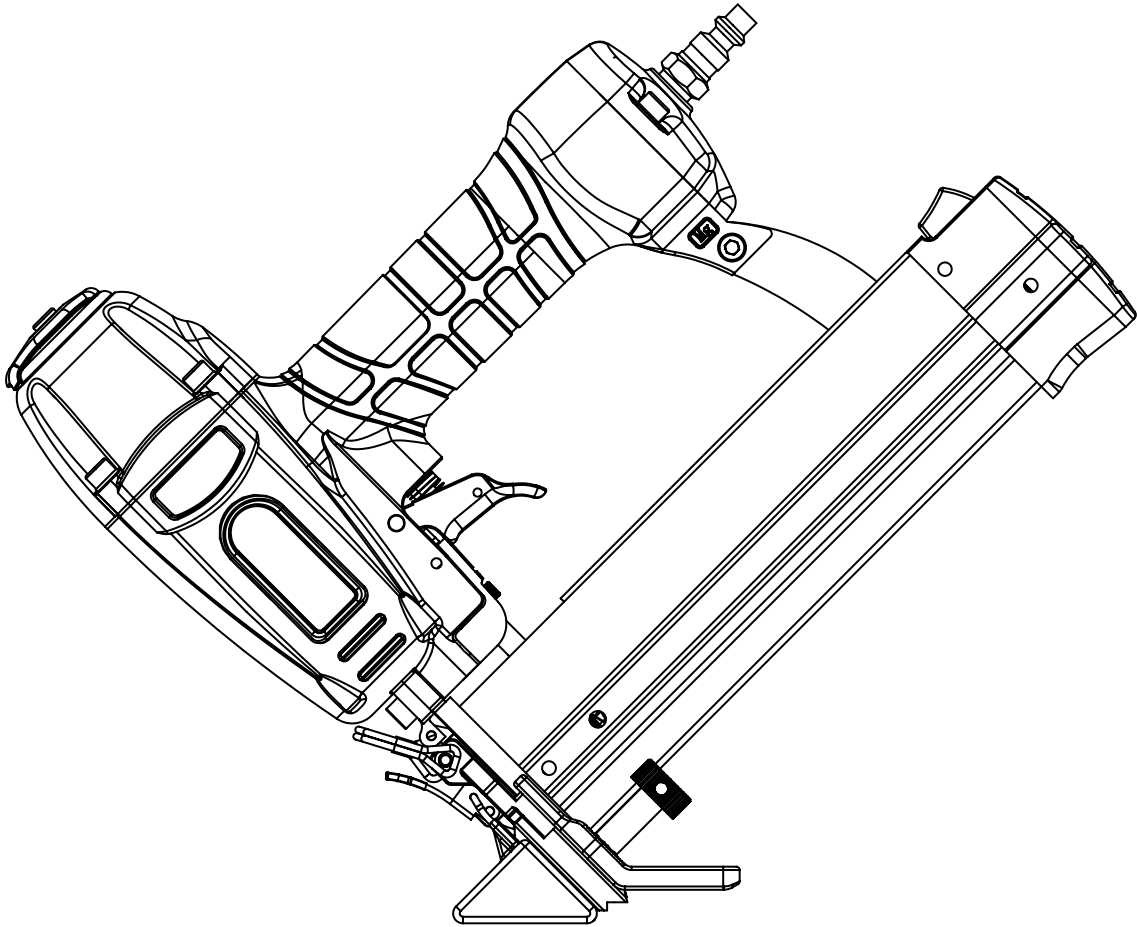

**MODEL 61741**

# **4-IN-ONE PNEUMATIC FLOORING NAILER**

**Instruction Manual**



## ***NEED HELP? CONTACT US!***

Have product questions? Need technical support? Please feel free to contact us:

 **1-800-232-1195 (M-F 8AM-5PM CST)**

 **TECHSUPPORT@WENPRODUCTS.COM**

**IMPORTANT:** Your new tool has been engineered and manufactured to WEN's highest standards for dependability, ease of operation, and operator safety. When properly cared for, this product will supply you years of rugged, trouble-free performance. Pay close attention to the rules for safe operation, warnings, and cautions. If you use your tool properly and for its intended purpose, you will enjoy years of safe, reliable service.

For replacement parts and the most up-to-date instruction manuals, visit ***WENPRODUCTS.COM***

## TABLE OF CONTENTS

---

Technical Data .....	2
Safety Rules .....	4
Get to Know Your Air Nailer .....	7
Assembly .....	7
Operation .....	9
Troubleshooting .....	11
Exploded View and Parts List .....	12
Maintenance .....	14
Warranty .....	15

## TECHNICAL DATA

---

Model Number:	WEN 61741
Minimum Operating Air Pressure:	60 PSI
Maximum Operating Air Pressure:	100 PSI
Nail Size:	18 Gauge
Nail Length Range:	5/8 to 2 in.
Staple Size:	1/4 in. Crown
Staple Length Range:	1/2 to 1-5/8 in.
Magazine Capacity:	100 nails/staples
Air Inlet:	1/4 in. NPT
Air Consumption:	1.7 CFM @ 80 PSI
Tool Weight:	3.4 lbs

## GENERAL SAFETY RULES

Hello! The purpose of the following safety symbols is to attract your attention to possible dangers. We don't want any of our beloved WEN customers accidentally injuring themselves. The safety symbols and the explanations with them deserve your careful attention and understanding. The safety warnings do not by themselves eliminate any danger. These instructions and warnings are not substitutes for proper accident prevention measures.



**Safety Alert Symbol:** Indicates danger, warning, or caution. This may be used in conjunction with other symbols. Always follow the safety precautions to reduce the risk of fire, electric shock and personal injury.

**WARNING** - Do not attempt to operate this tool until you have thoroughly read and understood all instructions, safety rules, etc., contained in this manual. Failure to comply can result in accidents involving fire, electric shock, or serious personal injury. Save this operator's manual and review frequently for continuing safe operation and instructing others who may use this tool.

Safe operation of this power tool requires that you read and understand this operator's manual and all labels affixed to the tool. Safety is a combination of common sense, staying alert, and knowing how your tool works.

# SAFETY RULES

---

Safety is a combination of common sense, staying alert and knowing how your item works. **SAVE THESE SAFETY INSTRUCTIONS.**

**WARNING:** To avoid mistakes and serious injury, do not use your tool until the following steps have been read and understood

1. **READ** and become familiar with this entire instruction manual, no matter how boring it may be. **LEARN** the tool's applications, limitations, and possible hazards.
2. **REGULATE AIR PRESSURE.** Use air pressure that is compatible with the ratings on the nameplate of the tool. Do not connect the tool to a compressor rated at over 175 psi even in the event of a regulator failure.
3. **USE ONLY** clean, dry and regulated air. Condensation from an air compressor can rust and damage the internal workings of the tool.
4. **ALWAYS** keep your work area clean, uncluttered, and well lit. **DO NOT** work on floor surfaces that are slippery with sawdust or wax.
5. **KEEP BYSTANDERS AT A SAFE DISTANCE** from the work area, especially when the tool is operating. **NEVER** allow children or pets near the tool.
6. **DO NOT FORCE THE TOOL** to do a job for which it was not designed.
7. **DRESS FOR SAFETY.** Do not wear loose clothing, gloves, neckties, or jewelry (rings, watches, etc.) when operating the tool. Inappropriate clothing and items can get caught in moving parts and draw you in. **ALWAYS** wear non-slip footwear and tie back long hair.
8. **WEAR A FACE MASK OR DUST MASK** to fight the debris produced by operation and ear protection to fight hearing loss. Everyone in the work area **MUST** wear safety glasses with side shields. These safety glasses must conform to ANSI Z87.1 requirements (approved glasses have "Z87" printed or stamped on them). It is the employer's responsibility to enforce the use of eye protection equipment by both the tool operator and others in the work area.



**WARNING:** Dust generated from certain materials can be hazardous to your health. Always operate the tool in a well-ventilated area and provide for proper dust removal. Use dust collection systems whenever possible.

9. **ALWAYS USE** an air hose that is rated at a maximum working pressure of at least 150 psi (10.3 bar) or 150% of the maximum system pressure.
10. **DO NOT USE BOTTLED GASES** to power this tool. Bottled compressed gases such as oxygen, carbon dioxide, nitrogen, hydrogen, propane, acetylene or air are not for use with pneumatic tools. Never use combustible gases or any other reactive gas as a power source for this tool. Danger of explosion and/or serious personal injury may result.
11. **USE COUPLINGS** that relieve all pressure from the tool when it is disconnected from the power supply. Use hose connectors that shut off the air supply from the compressor when the tool is disconnected.
12. **DISCONNECT** tool from air supply when not in use. Remove fasteners from magazine before leaving the area or passing the tool to another operator. Do not climb ladders, stairs, scaffoldings, etc. without disconnecting the tool. Do not carry a connected tool to another work area. Do not make adjustments, remove

## SAFETY RULES

---

magazine, perform maintenance or clear jammed fasteners while connected to the air supply. If the contact trip is adjusted when the tool is connected to the air supply with loaded nails, accidental discharge may occur.

13. **LOAD FASTENERS** after connecting the tool to the air supply. Otherwise, fasteners are at risk of being fired during connection. The tool's driving mechanism may cycle when it is connected to the air supply. Do not load fasteners or connect the air supply when the trigger or the safety is pressed down in order to prevent unintentional firings of a fastener.

14. **DO NOT REMOVE**, tamper with, or otherwise cause the tool, trigger or contact trip to become inoperable. Do not tape or tie the trigger or contact trip in the ON position. Do not remove springs from the contact trip. Make daily inspections for free movement of the trigger and contact trip. Uncontrolled discharge may result. Do not alter or modify the tool in any way.

15. **DO NOT OVERREACH**. Keep proper footing and balance at all times. Wear oil-resistant rubber-soled footwear. Keep the floor clear of oil, scrap, and other debris.

16. **MAINTAIN TOOLS PROPERLY**. **ALWAYS** keep tools clean and in good working order. Follow instructions for lubricating and changing accessories. Inspect tool before use. Do not operate if any portion of the tool, trigger, or contact trip is damaged, inoperable, disconnected, or altered. Leaking air, damaged parts, or missing parts should be repaired or replaced before use.

17. **ALWAYS ASSUME** that the tool contains fasteners. Do not point the tool at coworkers or yourself at any time, even if you think it will be really funny.

18. **MAKE THE WORKSHOP CHILDPROOF**. Use padlocks and master switches and **ALWAYS** remove starter keys. Keep bystanders, children and visitors away while operating the power tool. Distractions can cause you to lose control. When tool is not in use, it should be locked away in a safe place.

19. **DO NOT** operate the tool if you are under the influence of drugs, alcohol, or medication that may affect your ability to properly use the tool.

20. **REMOVE FINGER FROM TRIGGER** when not driving fasteners. Never carry the tool with your finger on the trigger.

21. **MAKE SURE HOSE** is free of obstructions or snags. Entangled or snarled hoses can cause a loss of balance.

22. **DO NOT DISCHARGE** fasteners into open air, concrete, stone, extremely hard woods, knots or any material too hard for the fastener to penetrate. Do not use the body of the tool or top cap as a hammer. Discharged fasteners may follow unexpected paths and cause bodily injury.

23. **DO NOT DRIVE FASTENERS** near the edge of your work material. The workpiece may split, causing the fastener to ricochet, injuring you or a co-worker. Be aware that the nail may follow the grain of the wood, causing it to protrude unexpectedly from the side of the work material. Drive the nail perpendicular to the grain to reduce risk of injury.

24. **DO NOT DRIVE NAILS** onto the heads of other fasteners. Do not use the tool at too steep of an angle. Personal injury from strong recoil, jammed fasteners, or ricocheted nails may result.

25. **BE AWARE** of material thickness when using the nailer. A protruding nail may cause injury.

## **SAFETY RULES**

---

26. **KNOW** that when the tool is being utilized at pressures on the high end of its operating range, nails can be driven completely through thin or very soft work material. Make sure the pressure in the compressor is set so that nails are set into the material and not pushed completely through.
27. **KEEP HANDS AND BODY PARTS CLEAR** of immediate work area. Hold workpiece with clamps when necessary to keep body parts out of potential harm. Be sure the workpiece is properly secured before pressing the nailer against the material. The contact trip may cause the work material to shift unexpectedly.
28. **DO NOT USE THE TOOL** in the presence of flammable dust, gases or fumes. The tool may produce a spark that could ignite gases causing a fire. Driving a nail into another nail may also cause a spark.
29. **KEEP FACE AND BODY PARTS** away from the back of the tool cap when working in restricted areas. Sudden recoil can result in impact to the body, especially when nailing into hard or dense material.
30. **GRIP THE TOOL FIRMLY** to maintain control while still allowing it to recoil away from the work surface as the fastener is driven. In bump action mode (contact actuation mode), allowing the contact trip to recontact the work surface before the trigger is released will fire an unwanted fastener.
31. **KEEP ALERT.** Watch what you are doing. Use common sense. Do not operate any tool when you are tired.
32. **USE PROPER EXTENSION CORDS.** When using an air compressor outdoors, use only rounded jackets extensions cords. These are intended for outside use. See manufacturer's manual for the AWG required for the compressor's amperage draw.
33. **PAY ATTENTION TO AIR HOSE AND THEIR CONNECTIONS.** Don't trip over the hoses. It isn't fun. Also, make sure the connections are nice and tight.
34. **WHEN CONNECTING TO THE AIR SUPPLY,** the tool is at risk of possibly firing fasteners. Be aware of this and do not aim the gun at anything you do not want to shoot a nail into.
35. **DO NOT DEPRESS THE CONTACT TRIP OR THE TRIGGER WHEN LOADING.**
36. **IF THE FASTENERS ARE JAMMED,** disconnect the tool from the air supply first before removing the jammed fasteners.
37. This tool is equipped with safe bracket that can adjust the depth of the driver. When adjusting the depth of the driver, first disconnect the tool from the air and rotate nut by thumb to satisfactory position.
38. **DO NOT** attempt to fire into hard or brittle materials such as concrete, steel or tile.

**WARNING:** The warnings, cautions, and instructions explained in this manual cannot cover all possible conditions and situations that may occur. It must be understood by the operator that **COMMON SENSE AND CAUTION ARE FACTORS WHICH CANNOT BE BUILT INTO THIS PRODUCT, BUT MUST BE SUPPLIED BY THE OPERATOR.** So don't do anything stupid.

# GET TO KNOW YOUR AIR NAILER

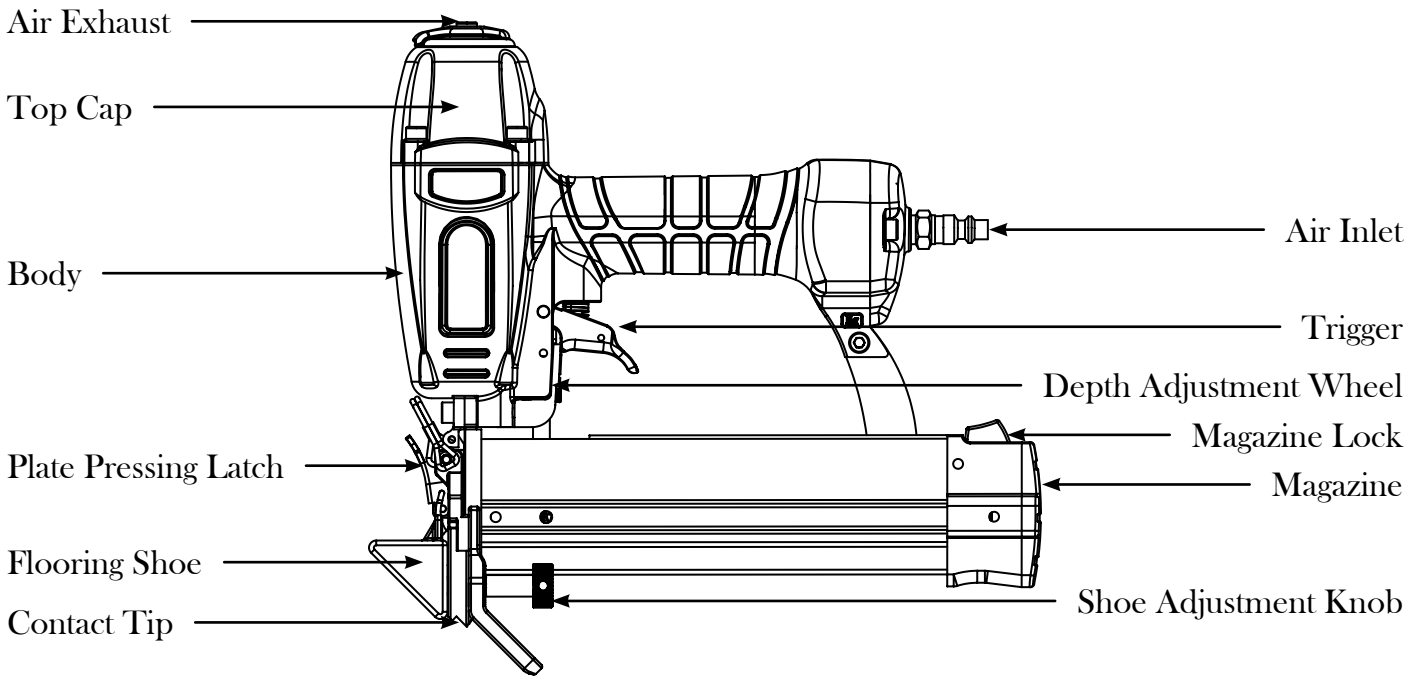

## ASSEMBLY

### UNPACKING

Be sure to remove all loose parts from the packaging. Refer to the table to the right and check all the parts are complete. If you find any pieces that are missing or wrong, please contact our customer service.

Your air tool is fully assembled when you receive it. Before using it, attach the air line and desired air system accessories. See Fig. 1 for the recommended accessories and connection order. Be sure the air hose is depressurized when installing or removing adapters to the air line.

PART	QTY
Combination Nailer/Stapler	1
3mm Hex Wrench	1
4mm Hex Wrench	1
Air Tool Oil	1
No-Mar Tip	1
Manual	1

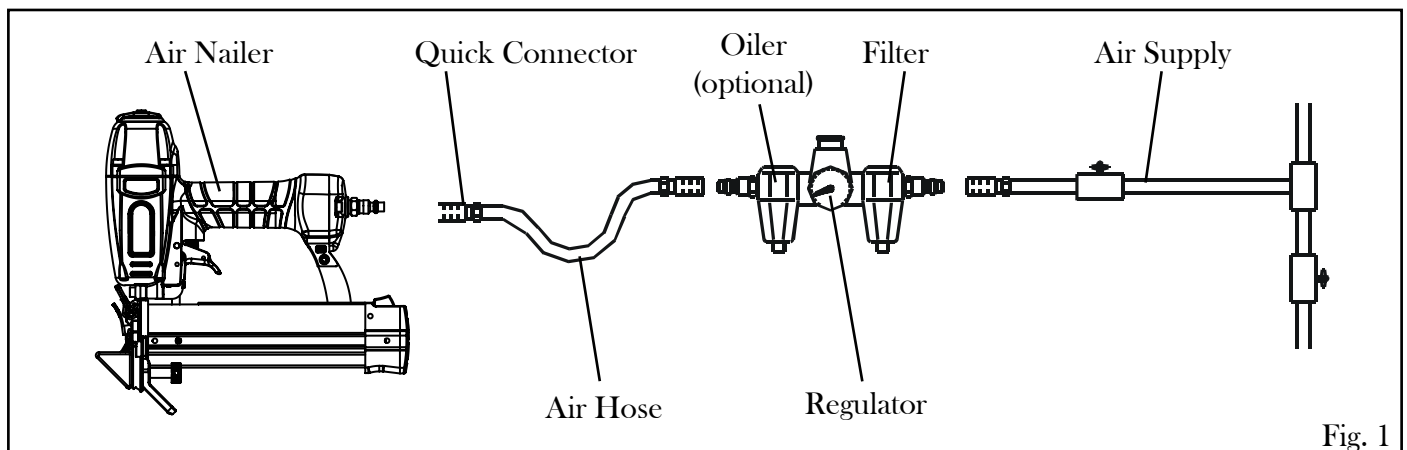

Fig. 1

# ASSEMBLY

## LUBRICATION

This tool requires lubrication before each use (especially the first use). If an inline oiler is used, manual lubrication through the air inlet is not required.

**NOTE:** The work surface can become damaged by excessive lubrication. Proper lubrication is the owner's responsibility. Failure to lubricate the tool properly will dramatically shorten the life of the tool and void the warranty.

1. Disconnect the air supply from the tool to add lubricant.
2. Turn the tool so the air inlet is facing up. Place 2 drops of oil into the air inlet (Fig. 2).
3. After adding oil, briefly run the tool. Wipe off any excess oil from the exhaust.

## CONNECTING THE TOOL TO AN AIR SUPPLY

**NOTE:** Never aim the tip of the nailer towards yourself or others. Do not operate when the air pressure is outside of the recommended range (60 to 100 PSI). Make sure magazine is empty when connecting to air supply.

1. Determine if the tool needs oil and, if necessary, place two drops of oil in the air inlet (Fig. 2 - 1) as outlined above in the Lubrication section.
2. Turn the compressor on and set the Regulator (Fig. 1 - Regulator) to the proper pressure according to the size and type of fastener being used. The air pressure range should be between 60 PSI and 100 PSI.
3. Connect the tool to the air supply (Fig. 1).

## LOADING THE FASTENERS (Fig. 3)

**NOTE:** Always load the fasteners after connecting the tool to its air supply. Otherwise, unwanted misfires may occur during connection. Never aim the tip towards yourself or others.

1. Depress the Lock (Fig. 3 - 1) to release the movable magazine (Figure 3 - 2) and pull the magazine out fully.
2. Place a full clip of the specified type and size fasteners on the fixed magazine (Fig. 3 - 3), 100 fasteners may be loaded in the magazine.
3. Push the movable magazine assembly (Fig. 3 - 2) forward until it is locked.

## ADJUSTING THE DEPTH ADJUSTMENT WHEEL

Use the depth adjustment wheel (Fig. 4) found directly underneath the trigger to adjust the depth of the fired nails. Turn the wheel to the left for deeper nails, or turn to the right for shallower nails.

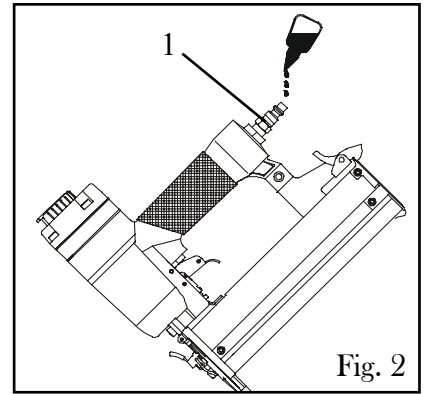

Fig. 2

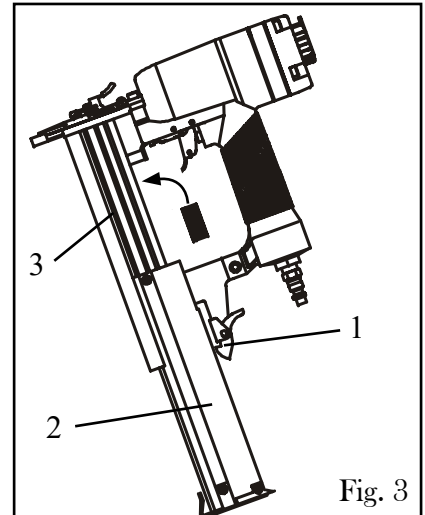

Fig. 3

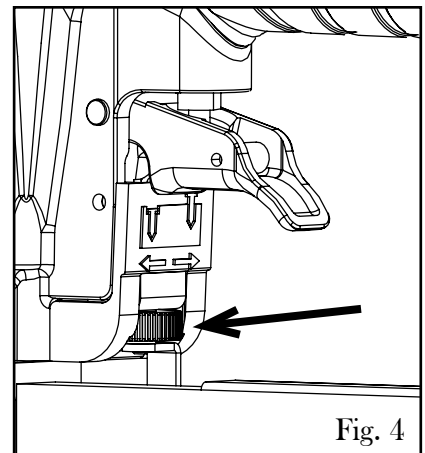

Fig. 4



# OPERATION

Test the driving depth in a sample piece of wood before using. If the fasteners are being driven too far or not far enough, adjust the regulator to provide less air pressure or more air pressure.

1. Check that the air supply is correctly connected to the tool at the correct pressure and the fasteners have been loaded into the magazine.

2. Hold the nailer and press the drive guide (Fig. 5 - 1) flush against the work surface, making sure that the tool is straight. Gently press the trigger (Fig. 5 - 2) to drive the fastener.

## DRIVING MODES

The tool has two driving modes. In order to operate the tool, both the contact trip and the trigger switch must be activated.

**Single Driving Mode:** put the driving guide on the work surface, making sure the contact trip is being pressed down. Then pull the trigger to drive a fastener.

**Continuous Driving Mode:** hold down the trigger. Repeatedly impact the contact trip against the working surface to drive the fasteners. The tool will drive one fastener every time the contact trip is activated.

## CLEARING JAMMED NAILS



**WARNING:** disconnect air line from the tool and remove all fasteners before removing jammed nails to avoid personal injury.

If a nail becomes jammed in the nosepiece, keep the tool pointed away from yourself and others and follow these steps:

1. Disconnect air supply from tool.
2. Press magazine lock to release movable magazine. Remove nails from magazine. Remove flooring shoe (if installed; see next section).
3. Open jam-clearing latch and lift up on the front plate.
4. Remove jammed nail, using pliers or other tools if necessary.
5. If the piston assembly is in the down position, insert screwdriver or other rod into nosepiece and push the piston back in position.
6. Remove rod and close front plate.
7. Close latch to secure front plate to nosepiece. Make sure the trigger and contact trip move freely without sticking or binding.
8. Reattach nailer to air supply.
9. Load the magazine. Test fire a nail into scrap wood to confirm the nailer is working properly again.



**NOTE:** If nails continue to jam in the nosepiece, contact WEN customer server at 1-800-232-1195.

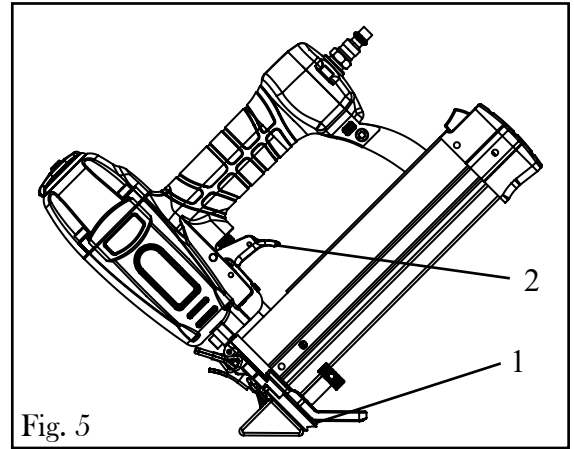

# OPERATION



**WARNING:** Never uninstall or install the flooring shoe while the nailer/stapler is attached to its air supply or while nails are loaded in the magazine.

## REMOVING THE FLOORING SHOE

For general installation at a 90-degree angle, use the following directions to uninstall the flooring shoe.

1. Open the plate pressing latch (Fig. 6).
2. Open the D-ring pin by unclasp the hook (Fig. 7 - A) from the pin.
3. Remove the pin from the floor shoe (Fig. 7 - B).
4. Slide the flooring shoe off (Fig. 8).
5. Close the plate pressing latch (Fig. 9).

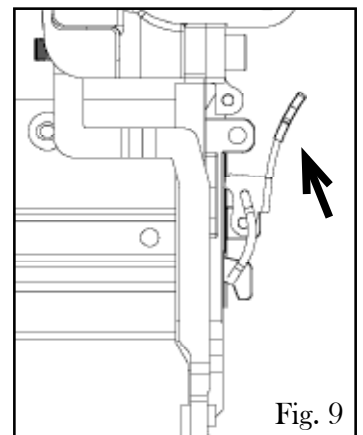
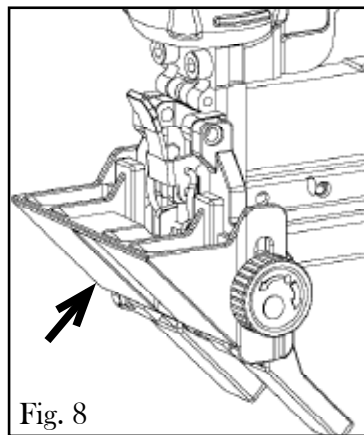
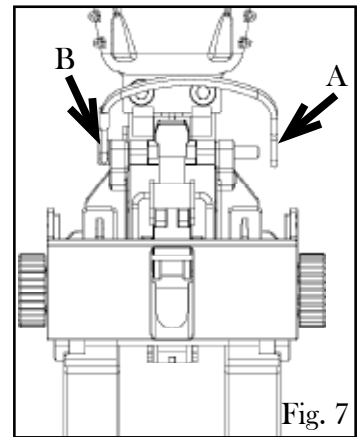
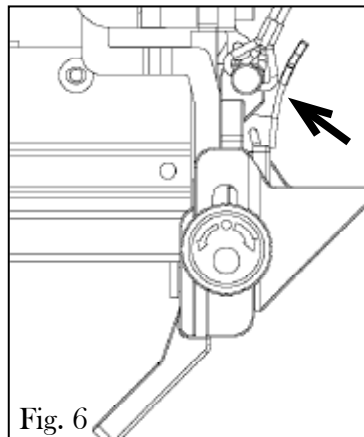

## INSTALLING THE FLOORING SHOE

1. Open the plate pressing latch (Fig. 9).
2. Attach the flooring shoe in place by sliding in the pin. Reattach the hook to the end of the pin (Fig. 7 - A).
3. Close plate pressing latch (Fig. 6). Remove no-mar tip.

## USING THE FLOORING SHOE

1. Make sure no-mar tip has been removed from nailer.
2. Turn the depth adjustment wheel (Fig. 4) to set the depth of the fired nail. For flooring, it is suggested to always fire at the deepest depth.
2. Loosen the shoe adjusting knobs on either side of the shoe so that the upper part of the shoe lays flush against the top of the flooring (Fig. 10).
3. Place the contact piece flush against the corner of the tongue of the flooring. Push the nailer towards the flooring so the contact piece fully contacts the tongue of the flooring (Fig. 10).
4. Place the nose tip flush with the tip flush with the corner of the tongue of the flooring. Once you are sure that the contact piece is flush with the hardwood, fasten the adjusting knobs in place.
5. Pull the trigger. The fastener will be fired at a 45-degree angle through the flooring tongue and into the subfloor, through the hardwood and into the ground (Fig. 11).

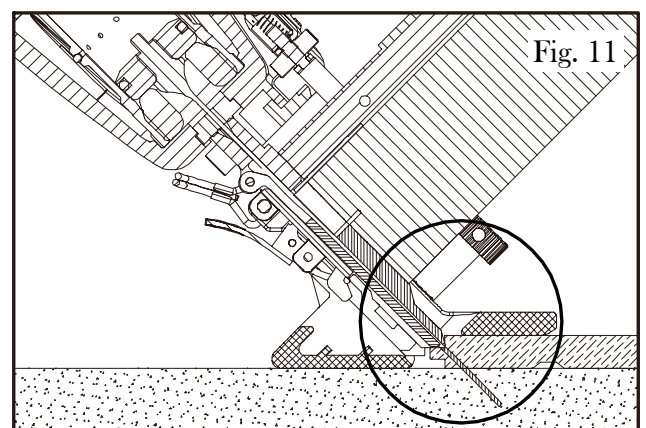
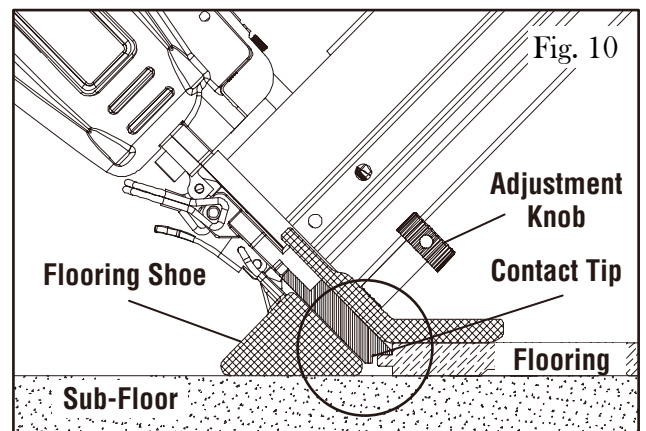

## OPERATION

### FINISHING APPLICATIONS

In order to prevent marring and damage to the surface of your work piece, attach the no-mar tip (Fig. 12) before attempting any finish nailing.

To attach the no-mar tip, disconnect the nailer from the air supply, then slide the tip onto the drive guide (Fig. 13).

**NOTE:** The no-mar tip is only to be used for the purpose of finishing applications. Do not use for flooring applications.

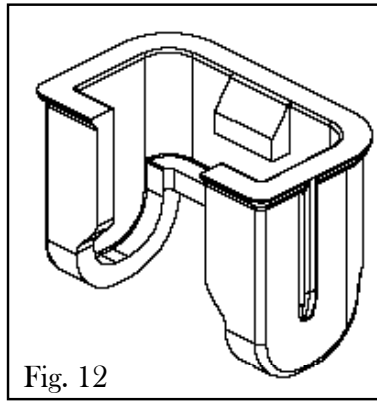

Fig. 12

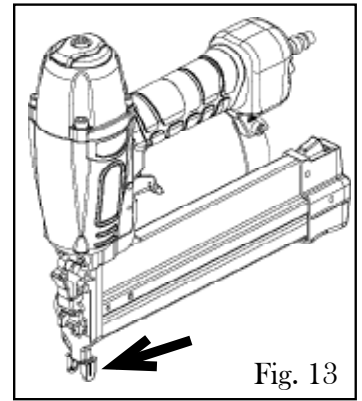

Fig. 13

## TROUBLESHOOTING

Stop using the tool immediately if any of the following problems occur. Serious personal injury could occur. Any repairs or replacements must be done by a qualified person or an authorized service center only.

PROBLEM	CAUSE	SOLUTION
Air leaking at trigger area	<ol style="list-style-type: none"> <li>1. O-ring in trigger valve is damaged.</li> <li>2. Trigger valve head is damaged.</li> <li>3. Trigger valve stem, seal or O-ring is damaged.</li> </ol>	<ol style="list-style-type: none"> <li>1. Check and replace O-ring.</li> <li>2. Check and replace trigger valve head.</li> <li>3. Check and replace trigger valve stem, seal or O-ring.</li> </ol>
Air leaking between body and drive guide	Damaged piston O-ring or bumper.	Check and replace O-ring or bumper.
Air leaking between body and cylinder cap.	<ol style="list-style-type: none"> <li>1. Screw loose.</li> <li>2. Damaged gasket.</li> </ol>	<ol style="list-style-type: none"> <li>1. Tighten screws.</li> <li>2. Check and replace seal.</li> </ol>
Blade driving fastener too deep	<ol style="list-style-type: none"> <li>1. Worn bumper.</li> <li>2. Air pressure is too high.</li> </ol>	<ol style="list-style-type: none"> <li>1. Replace bumper.</li> <li>2. Adjust the air pressure.</li> </ol>
Running slowly or has power loss	<ol style="list-style-type: none"> <li>1. Insufficient oil.</li> <li>2. Insufficient air supply.</li> <li>3. Broken spring in cylinder cap.</li> <li>4. Exhaust port in cylinder cap is blocked.</li> </ol>	<ol style="list-style-type: none"> <li>1. Lubricate as instructed.</li> <li>2. Check air supply.</li> <li>3. Replace spring.</li> <li>4. Replace damaged internal parts.</li> </ol>
Tool skips a fastener	<ol style="list-style-type: none"> <li>1. Worn bumper or damaged spring (72).</li> <li>2. Dirt in drive guide.</li> <li>3. Inadequate airflow to tool.</li> <li>4. Worn or dry O-ring on piston.</li> <li>5. Damaged O-ring on trigger valve.</li> <li>6. Cylinder cap seal leaking.</li> </ol>	<ol style="list-style-type: none"> <li>1. Replace bumper or pusher spring.</li> <li>2. Clean drive channel of front plate.</li> <li>3. Check hose and compressor fittings.</li> <li>4. Replace O-ring or lubricate.</li> <li>5. Replace O-ring.</li> <li>6. Replace seal.</li> </ol>
Staple not firing in the correct place for flooring operations	No-mar tip is attached when it shouldn't be.	Remove the no-mar tip.
Fasteners are jammed	<ol style="list-style-type: none"> <li>1. Joint guider is worn.</li> <li>2. Fasteners are the wrong size or damaged.</li> <li>3. Magazine or front plate screws are loose.</li> <li>4. Blade in piston assembly is damaged.</li> </ol>	<ol style="list-style-type: none"> <li>1. Replace joint guider.</li> <li>2. Use the recommended and undamaged fasteners.</li> <li>3. Tighten screws.</li> <li>4. Replace piston assembly.</li> </ol>

# EXPLODED VIEW AND PARTS LIST

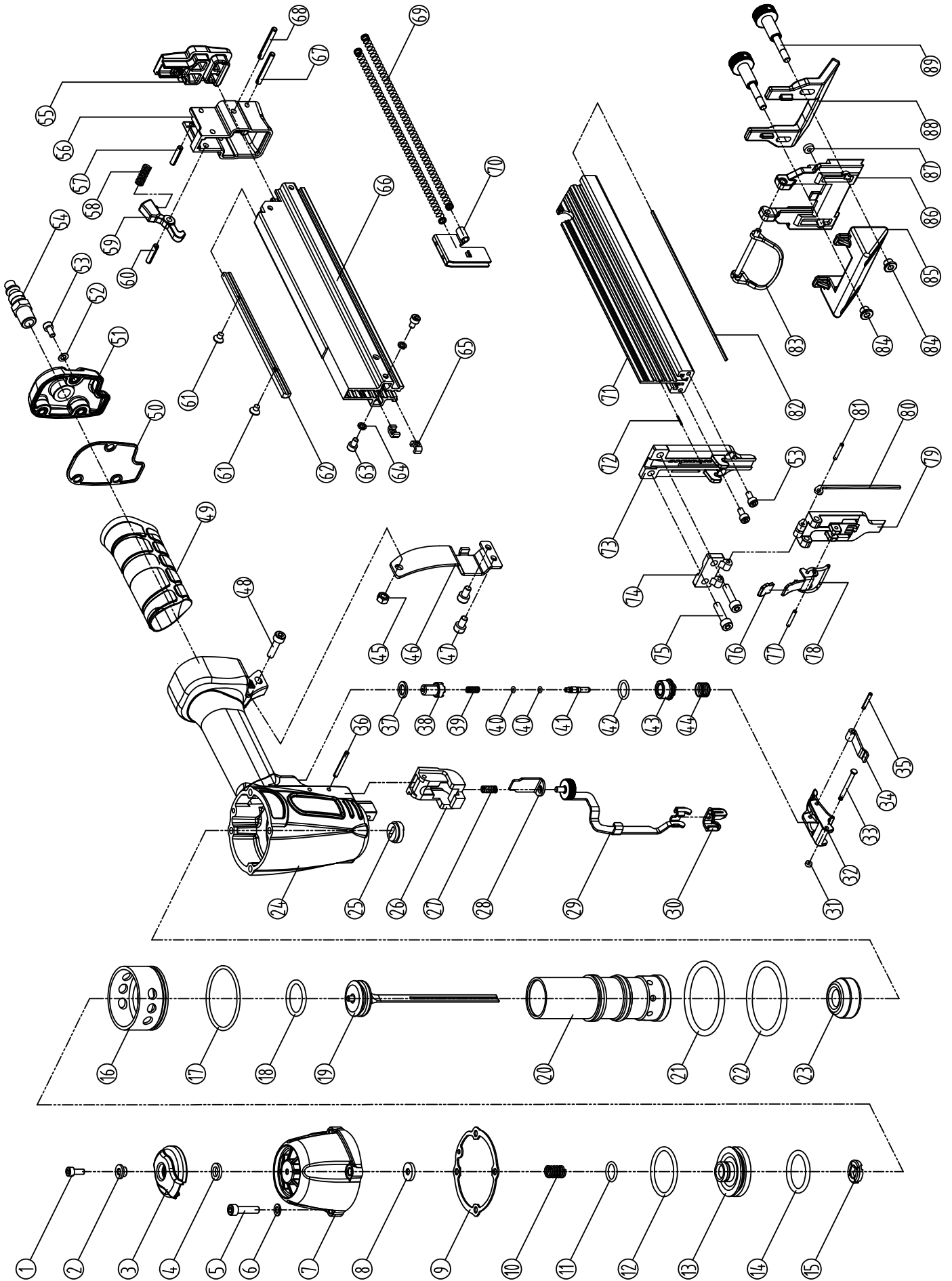

## EXPLODED VIEW AND PARTS LIST

No.	Part No.	Description	Qty.
1	61741-001	Socket head cap screw, M4x10	1
2	61741-002	Bushing	1
3	61741-003	Exhaust Cover	1
4	61741-004	Seal	1
5	61741-005	Socket head cap screw, M5x22	4
6	61741-006	Washer	4
7	61741-007	Cylinder Cap	1
8	61741-008	Valve Seal	1
9	61741-009	Cylinder Cap Gasket	1
10	61741-010	Spring	1
11	61741-011	O-ring, Ø15.7x2	1
12	61741-012	O-ring, Ø38.8x3	1
13	61741-013	Valve	1
14	61741-014	O-ring, Ø33.5x3.5	1
15	61741-015	Stop Washer	1
16	61741-016	Collar	1
17	61741-017	O-ring, Ø50.5x2.5	1
18	61741-018	O-ring, Ø28.3x3	1
19	61741-019	Piston Assembly	1
20	61741-020	Cylinder	1
21	61741-021.1	O-ring, Ø36.3x2.5	1
22	61741-021.2	O-ring, Ø35.3x2.5	1
23	61741-022	Bumper	1
24	61741-023	Body	1
25	61741-024	Joint Guide	1
26	61741-026	Safety Guide	1
27	61741-027	Spring	1
28	61741-028	Safety Bracket A	1
29	61741-029	Safety Bracket Assembly	1
30	61741-030	No-Mar Tip	1
31	61741-040B.1	Rubber Washer	1
32	61741-041	Trigger	1
33	61741-040B.2	Trigger Pin	1
34	61741-038	Trigger Leaf Spring	1
35	61741-039	Pin	1
36	61741-025	Spring Pin	1
37	61741-031B.1	Trigger Valve Head Seal	1
38	61741-031B	Trigger Valve Head	1
39	61741-032	Trigger Valve Spring	1
40	61741-033	O-ring, Ø5.5x1.5	2
41	61741-034	Trigger Valve Stem	1
42	61741-035	O-ring, Ø15x1.9	1
43	61741-036	Trigger Valve Guide	1
44	61741-037	Spring	1
45	61741-083	Lock Nut, M5	1
46	61741-081	Support	1

No.	Part No.	Description	Qty.
47	61741-080	Socket head cap screw, M4x8	2
48	61741-048	Socket head cap screw, M5x18	1
49	61741-084	Grip	1
50	61741-085	End Cap Gasket	1
51	61741-086	End Cap	1
52	61741-087	Washer	3
53	61741-050	Socket head cap screw, M4x16	5
54	61741-088	Air Plug, 1/4" NPT	1
55	61741-077	Rubber Cushion	1
56	61741-073	Magazine Cap	1
57	61741-039	Pin	1
58	61741-076	Reset Spring	1
59	61741-075	Magazine Lock	1
60	61741-074	Pin	1
61	61741-070	Screw, M4x6	2
62	61741-072	Rail	1
63	61741-069	Socket head cap screw, M4x6	2
64	61741-068	Spring Washer	2
65	61741-067	Block	2
66	61741-071	Movable Magazine	1
67	61741-079	Pin	1
68	61741-078	Pin	1
69	61741-066	Magazine Spring	2
70	61741-065	Magazine Follower	1
71	61741-063	Fixed Magazine	1
72	61741-062	Pin	1
73	61741-061	Drive Guide	1
74	61741-060	Spacer	1
75	61741-059	Socket head cap screw, M5x20	2
76	61741-053	Latch Sleeve	1
77	61741-055	Coil Spring Pin	1
78	61741-054	Latch Assembly	1
79	61741-056	Cover Plate A	1
80	61741-057	Guide Rail	1
81	61741-058	Coil Spring Pin	1
82	61741-064	Rail	1
83	61741-052B	D-ring	1
84	61741B-084	Bushing	2
85	61741B-085	Shoe (Lower)	1
86	61741-047B	Shoe Plate	1
87	61741B-087	Washer	1
88	61741B-088	Shoe (Upper)	1
89	61741B-09	Shoe Adjustment Knob	2

## MAINTENANCE

---

**WARNING:** Remove nails from magazine and disconnect the air supply before performing any maintenance.

Routine lubrication of the tool is required for best performance. Oil added through the airline connection will lubricate internal parts. An automatic airline oiler is recommended but oil may be added manually before every operation or after about 1 hour of continuous use. Only a few drops of oil at a time are necessary. Too much oil will collect inside the tool and be blown out during the exhaust cycle. **ONLY USE PNEUMATIC TOOL OIL.** Do not use detergent oil or additives, as these lubricants will cause accelerated wear to the seal in the tool.

Dirt and water in the air supply are major causes of pneumatic tool wear. Use a filter/oiler for better performance and longer lifetime for your tool. The filter must have adequate flow capacity for the specific application. Consult the manufacturer's instructions for proper maintenance of your filter. Keep tools clean for better and safer performance. Use nonflammable cleaning solutions only if necessary (**CAUTION:** Such solutions may damage O-ring and other tool parts). **DO NOT SOAK THE TOOL.**

## **LIMITED TWO YEAR WARRANTY**

---

WEN Products is committed to build tools that are dependable for years. Our warranties are consistent with this commitment and our dedication to quality.

**LIMITED WARRANTY OF WEN CONSUMER POWER TOOLS PRODUCTS FOR HOME USE**  
**GREAT LAKES TECHNOLOGIES, LLC** (“Seller”) warrants to the original purchaser only, that all WEN consumer power tools will be free from defects in material or workmanship for a period of two (2) years from date of purchase. Ninety days for all WEN products, if the tool is used for professional use.

**SELLER’S SOLE OBLIGATION AND YOUR EXCLUSIVE REMEDY** under this Limited Warranty and, to the extent permitted by law, any warranty or condition implied by law, shall be the repair or replacement of parts, without charge, which are defective in material or workmanship and which have not been misused, carelessly handled, or misrepaired by persons other than Seller or Authorized Service Center. To make a claim under this Limited Warranty, you must make sure to keep a copy of your proof of purchase that clearly defines the Date of Purchase (month and year) and the Place of Purchase. Place of purchase must be a direct vendor of Great Lakes Technologies, LLC. Third party vendors such as garage sales, pawn shops, resale shops, or any other secondhand merchant void the warranty included with this product. Contact techsupport@wenproducts.com or 1-800-232-1195 to make arrangements for repairs and transportation.

When returning a product for warranty service, the shipping charges must be prepaid by the purchaser. The product must be shipped in its original container (or an equivalent), properly packed to withstand the hazards of shipment. The product must be fully insured with a copy of the warranty card and/or the proof of purchase enclosed. There must also be a description of the problem in order to help our repairs department diagnose and fix the issue. Repairs will be made and the product will be returned and shipped back to the purchaser at no charge.

**THIS LIMITED WARRANTY DOES NOT APPLY TO ACCESSORY ITEMS THAT WEAR OUT FROM REGULAR USAGE OVER TIME INCLUDING BELTS, BRUSHES, BLADES, ETC.**  
**ANY IMPLIED WARRANTIES SHALL BE LIMITED IN DURATION TO ONE (1) YEAR FROM DATE OF PURCHASE. SOME STATES IN THE U.S., SOME CANADIAN PROVINCES DO NOT ALLOW LIMITATIONS ON HOW LONG AN IMPLIED WARRANTY LASTS, SO THE ABOVE LIMITATION MAY NOT APPLY TO YOU.**

**IN NO EVENT SHALL SELLER BE LIABLE FOR ANY INCIDENTAL OR CONSEQUENTIAL DAMAGES (INCLUDING BUT NOT LIMITED TO LIABILITY FOR LOSS OF PROFITS) ARISING FROM THE SALE OR USE OF THIS PRODUCT. SOME STATES IN THE U.S. AND SOME CANADIAN PROVINCES DO NOT ALLOW THE EXCLUSION OR LIMITATION OF INCIDENTAL OR CONSEQUENTIAL DAMAGES, SO THE ABOVE LIMITATION OR EXCLUSION MAY NOT APPLY TO YOU.**

**THIS LIMITED WARRANTY GIVES YOU SPECIFIC LEGAL RIGHTS, AND YOU MAY ALSO HAVE OTHER RIGHTS WHICH VARY FROM STATE TO STATE IN THE U.S., PROVINCE TO PROVINCE IN CANADA AND FROM COUNTRY TO COUNTRY.**

**THIS LIMITED WARRANTY APPLIES ONLY TO PORTABLE ELECTRIC TOOLS, BENCH POWER TOOLS, OUTDOOR POWER EQUIPMENT AND PNEUMATIC TOOLS SOLD WITHIN THE UNITED STATES OF AMERICA, CANADA AND THE COMMONWEALTH OF PUERTO RICO. FOR WARRANTY COVERAGE WITHIN OTHER COUNTRIES, CONTACT THE WEN CUSTOMER SUPPORT LINE.**

**THANKS FOR  
REMEMBERING**  <sup>®</sup>