

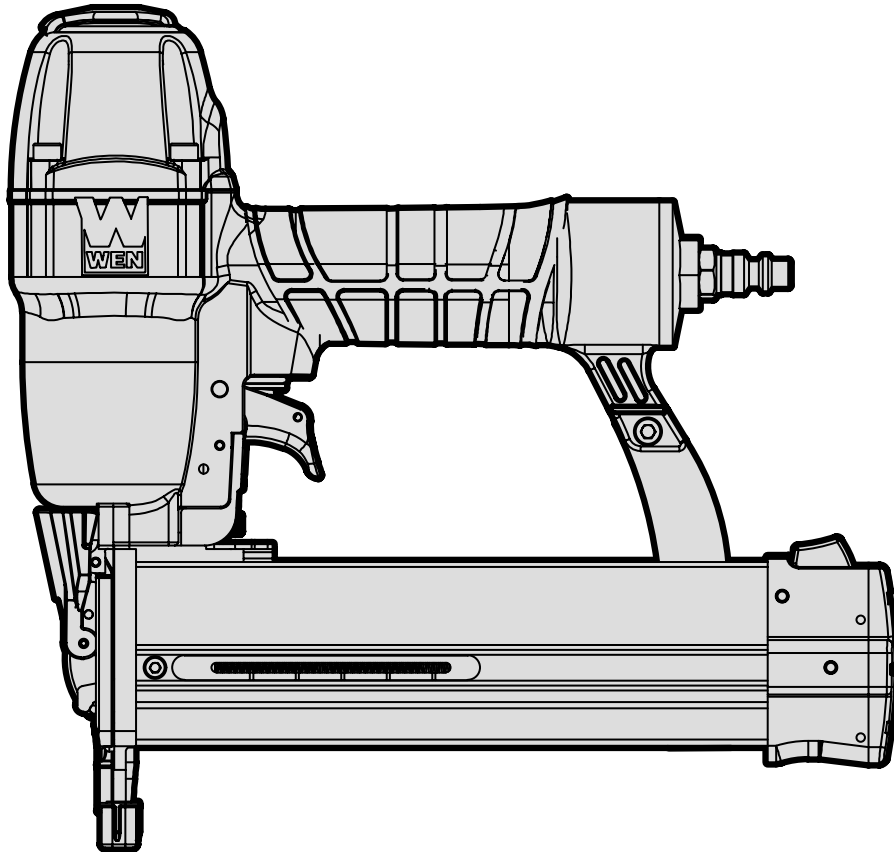

MODEL 61721, 61723K

18-GAUGE 2-INCH BRAD NAILER

Instruction Manual



NEED HELP? CONTACT US!

Have product questions? Need technical support? Please feel free to contact us:



1-847-429-9263 (M-F 8AM-5PM CST)



TECHSUPPORT@WENPRODUCTS.COM

IMPORTANT: Your new tool has been engineered and manufactured to WEN's highest standards for dependability, ease of operation, and operator safety. When properly cared for, this product will supply you years of rugged, trouble-free performance. Pay close attention to the rules for safe operation, warnings, and cautions. If you use your tool properly and for its intended purpose, you will enjoy years of safe, reliable service.

For replacement parts and the most up-to-date instruction manuals, visit ***WENPRODUCTS.COM***

CONTENTS

WELCOME	3
Introduction	3
Specifications.....	3
SAFETY	4
General Safety Rules	4
Brad Nailer Safety Warnings	6
BEFORE OPERATING	7
Unpacking & Packing List.....	7
Know Your Brad Nailer.....	7
Preparation & Adjustments.....	8
OPERATION & MAINTENANCE	10
Operation	10
Maintenance.....	12
Troubleshooting Guide.....	13
Exploded View & Parts List.....	14
Warranty Statement	16

To purchase air compressors, air hoses, and other accessories, visit **WENPRODUCTS.COM**

INTRODUCTION

Thanks for purchasing the WEN Brad Nailer. We know you are excited to put your tool to work, but first, please take a moment to read through the manual. Safe operation of this tool requires that you read and understand this operator's manual and all the labels affixed to the tool. This manual provides information regarding potential safety concerns, as well as helpful assembly and operating instructions for your tool.

 Indicates danger, warning, or caution. The safety symbols and the explanations with them deserve your careful attention and understanding. Always follow the safety precautions to reduce the risk of fire, electric shock or personal injury. However, please note that these instructions and warnings are not substitutes for proper accident prevention measures.

NOTE: The following safety information is not meant to cover all possible conditions and situations that may occur. WEN reserves the right to change this product and specifications at any time without prior notice.

At WEN, we are continuously improving our products. If you find that your tool does not exactly match this manual, please visit wenproducts.com for the most up-to-date manual or contact our customer service at **1-847-429-9263**.

Keep this manual available to all users during the entire life of the tool and review it frequently to maximize safety for both yourself and others.

SPECIFICATIONS

Model Number	61721, 61723K
Min. Operating Pressure	60 PSI
Max. Operating Pressure	115 PSI
Air Inlet	1/4" NPT
Nail Type	18-Gauge Brad Nails
Nail Length	3/8" to 2"
Magazine Capacity	100 Fasteners
Air Consumption (Cont.)	1.8 CFM at 80 PSI
Product Dimensions	10-1/8" x 10-3/4" x 2-5/8"
Product Weight	2.8 lbs

GENERAL SAFETY RULES

 **WARNING!** Read all safety warnings and all instructions. Failure to follow the warnings and instructions may result in electric shock, fire and/or serious injury.

Safety is a combination of common sense, staying alert and knowing how your item works. The term “power tool” in the warnings refers to your mains-operated (corded) power tool or battery-operated (cordless) power tool.

SAVE THESE SAFETY INSTRUCTIONS.

WORK AREA SAFETY

- 1. Keep work area clean and well lit.** Cluttered or dark areas invite accidents.
- 2. Do not operate power tools in explosive atmospheres, such as in the presence of flammable liquids, gases or dust.** Power tools create sparks which may ignite the dust or fumes.
- 3. Keep children and bystanders away while operating a power tool.** Distractions can cause you to lose control.

ELECTRICAL SAFETY

- 1. Power tool plugs must match the outlet. Never modify the plug in any way. Do not use any adapter plugs with earthed (grounded) power tools.** Unmodified plugs and matching outlets will reduce risk of electric shock.
- 2. Avoid body contact with earthed or grounded surfaces such as pipes, radiators, ranges and refrigerators.** There is an increased risk of electric shock if your body is earthed or grounded.
- 3. Do not expose power tools to rain or wet conditions.** Water entering a power tool will increase the risk of electric shock.
- 4. Do not abuse the cord. Never use the cord for carrying, pulling or unplugging the power tool. Keep cord away from heat, oil, sharp edges or moving parts.** Damaged or entangled cords increase the risk of electric shock.
- 5. When operating a power tool outdoors, use an extension cord suitable for outdoor use.** Use of a cord suitable for outdoor use reduces the risk of electric shock.

- 6. If operating a power tool in a damp location is unavoidable, use a ground fault circuit interrupter (GFCI) protected supply.** Use of a GFCI reduces the risk of electric shock.

PERSONAL SAFETY

- 1. Stay alert, watch what you are doing and use common sense when operating a power tool. Do not use a power tool while you are tired or under the influence of drugs, alcohol or medication.** A moment of inattention while operating power tools may result in serious personal injury.
- 2. Use personal protective equipment. Always wear eye protection.** Protective equipment such as a respiratory mask, non-skid safety shoes and hearing protection used for appropriate conditions will reduce the risk of personal injury.
- 3. Prevent unintentional starting. Ensure the switch is in the off-position before connecting to power source and/or battery pack, picking up or carrying the tool.** Carrying power tools with your finger on the switch or energizing power tools that have the switch on invites accidents.
- 4. Remove any adjusting key or wrench before turning the power tool on.** A wrench or a key left attached to a rotating part of the power tool may result in personal injury.
- 5. Do not overreach. Keep proper footing and balance at all times.** This enables better control of the power tool in unexpected situations.
- 6. Dress properly. Do not wear loose clothing or jewelry. Keep your hair and clothing away from moving parts.** Loose clothes, jewelry or long hair can be caught in moving parts.

GENERAL SAFETY RULES

 **WARNING!** Read all safety warnings and all instructions. Failure to follow the warnings and instructions may result in electric shock, fire and/or serious injury.

Safety is a combination of common sense, staying alert and knowing how your item works. The term “power tool” in the warnings refers to your mains-operated (corded) power tool or battery-operated (cordless) power tool.

SAVE THESE SAFETY INSTRUCTIONS.

7. If devices are provided for the connection of dust extraction and collection facilities, ensure these are connected and properly used. Use of dust collection can reduce dust-related hazards.

POWER TOOL USE AND CARE

1. Do not force the power tool. Use the correct power tool for your application. The correct power tool will do the job better and safer at the rate for which it was designed.

2. Do not use the power tool if the switch does not turn it on and off. Any power tool that cannot be controlled with the switch is dangerous and must be repaired.

3. Disconnect the plug from the power source and/or the battery pack from the power tool before making any adjustments, changing accessories, or storing power tools. Such preventive safety measures reduce the risk of starting the power tool accidentally.

4. Store idle power tools out of the reach of children and do not allow persons unfamiliar with the power tool or these instructions to operate the power tool. Power tools are dangerous in the hands of untrained users.

5. Maintain power tools. Check for misalignment or binding of moving parts, breakage of parts and any other condition that may affect the power tool's operation. If damaged, have the power tool repaired before use. Many accidents are caused by poorly maintained power tools.

6. Keep cutting tools sharp and clean. Properly maintained cutting tools with sharp cutting edges are less likely to bind and are easier to control.

7. Use the power tool, accessories and tool bits, etc. in accordance with these instructions, taking into account the working conditions and the work to be performed. Use of the power tool for operations different from those intended could result in a hazardous situation.

8. Use clamps to secure your workpiece to a stable surface. Holding a workpiece by hand or using your body to support it may lead to loss of control.

9. KEEP GUARDS IN PLACE and in working order.

SERVICE

1. Have your power tool serviced by a qualified repair person using only identical replacement parts. This will ensure that the safety of the power tool is maintained.

CALIFORNIA PROPOSITION 65 WARNING

Some dust created by power sanding, sawing, grinding, drilling, and other construction activities may contain chemicals, including lead, known to the State of California to cause cancer, birth defects, or other reproductive harm. Wash hands after handling. Some examples of these chemicals are:

- Lead from lead-based paints.
- Crystalline silica from bricks, cement, and other masonry products.
- Arsenic and chromium from chemically treated lumber.

Your risk from these exposures varies depending on how often you do this type of work. To reduce your exposure to these chemicals, work in a well-ventilated area with approved safety equipment such as dust masks specially designed to filter out microscopic particles.

BRAD NAILER SAFETY WARNINGS

⚠ WARNING! Do not let comfort or familiarity with the product replace strict adherence to product safety rules. Failure to follow the safety instructions may result in serious personal injury.

BRAD NAILER SAFETY

1. **THIS TOOL IS DESIGNED** for household use only, not for industrial or professional purposes. Do not force the tool to do a job for which it was not designed.
2. **INSPECT TOOL BEFORE USE.** Do not operate if any portion of the tool, trigger, or safety bracket is damaged, inoperable, disconnected, or altered. Leaking air, damaged parts, or missing parts should be repaired or replaced.
3. **GRIP THE TOOL FIRMLY** with both hands to maintain control while still allowing it to recoil away from the work surface as the fastener is driven.
4. **KEEP FACE AND BODY PARTS AWAY** from the back of the tool cap when working in restricted areas. Sudden recoil can result in impact to the body, especially when nailing into hard or dense material.
5. **DO NOT DISCHARGE** fasteners into open air, concrete, stone, extremely hard woods, knots or any material too hard for the fastener to penetrate.
6. **DO NOT DRIVE FASTENERS** near the edge of your work material. The workpiece may split, causing the fastener to ricochet, injuring you or a bystander. Be aware that the fastener may follow the grain of the wood, causing it to protrude unexpectedly from the side of the work material. Drive the fastener perpendicular to the grain to reduce risk of injury.
7. **DO NOT DRIVE FASTENERS** onto the heads of other fasteners. Do not use the tool at too steep of an angle. Personal injury from strong recoil, jammed fasteners, or ricocheted nails may result.
8. **BE AWARE** of material thickness when using the nailer. A protruding nail may cause injury.
9. **WHEN THE TOOL IS BEING UTILIZED AT PRESSURES ON THE HIGH END** of its operating range, fasteners can be driven completely through thin or very soft work material. Make sure the pressure in the compressor is set so that fasteners are set into the material and not pushed completely through.
10. **REMOVE FINGER FROM TRIGGER** when not driving fasteners. Never carry the tool with your finger on the trigger.
11. **IF THE FASTENERS ARE JAMMED**, disconnect the tool from the air supply first before removing the jammed fasteners.
12. **DISCONNECT** tool from air supply when not in use. Remove fasteners from magazine before leaving the area or passing the tool to another operator. Do not climb ladders, stairs, scaffoldings, etc. without disconnecting the tool. Do not carry a connected tool to another work area. Do not make adjustments, remove magazine, perform maintenance or clear jammed fasteners while connected to the air supply.
13. **DO NOT REMOVE**, tamper with, or otherwise cause the tool, trigger or safety bracket to become inoperable. Do not tape or tie the trigger or safety bracket in the ON position. Do not remove springs from the safety bracket. Make daily inspections for free movement of the trigger and safety bracket. Do not alter or modify the tool in any way.
14. **MAINTAIN TOOLS PROPERLY.** Always keep tools clean and in good working order. Follow instructions for lubricating, changing accessories and storage.

UNPACKING & PACKING LIST

UNPACKING

Carefully remove the brad nailer from the packaging and place it on a sturdy, flat surface. Make sure to take out all contents and accessories. Do not discard the packaging until everything is removed. Check the packing list below to make sure you have all of the parts and accessories. If any part is missing or broken, please contact customer service at **1-847-429-9263** (M-F 8-5 CST), or email techsupport@wenproducts.com.

61721 PACKING LIST

Description	Quantity
Brad Nailer	1
3mm Hex Wrench	1
4mm Hex Wrench	1
Air Tool Oil	1
Manual	1

*Model 61721 does NOT include a case or nails.

61723K PACKING LIST

Description	Quantity
Brad Nailer	1
3mm Hex Wrench	1
4mm Hex Wrench	1
Air Tool Oil	1
Manual	1
Case	1
18-Gauge 3/8-Inch Nails	500
18-Gauge 3/4-Inch Nails	500
18-Gauge 1-Inch Nails	500
18-Gauge 2-Inch Nails	500

KNOW YOUR BRAD NAILER

TOOL PURPOSE

Install trim, build birdhouses, and more with the help of your handy-dandy newfangled WEN Brad Nailer. Refer to the following diagrams to become familiarized with all the parts and controls of your tool. The components will be referred to later in the manual for assembly and operation instructions.

Exhaust

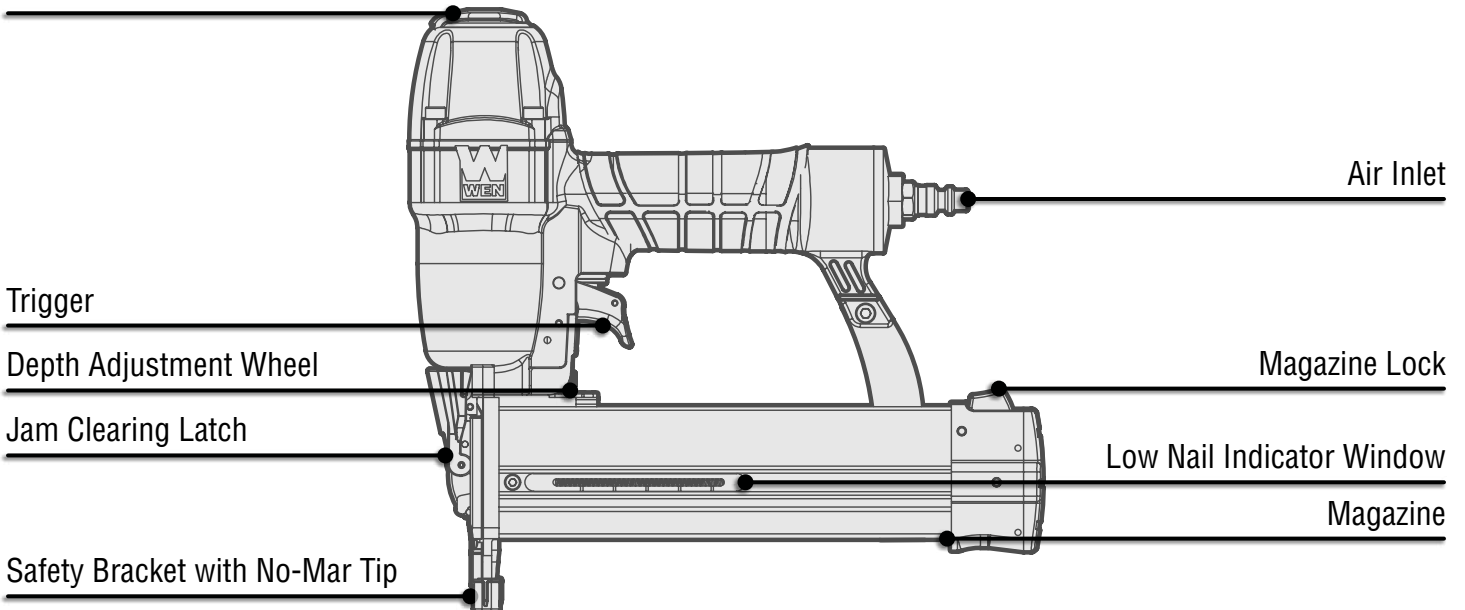

PREPARATIONS & ADJUSTMENTS

LUBRICATING THE TOOL

This tool requires lubrication before each use (especially the first use). If an inline oiler is used, manual lubrication through the air inlet is not required. Proper lubrication is the owner's responsibility. Failure to lubricate the tool properly will dramatically shorten the life of the tool and void the warranty.

NOTE: The surface of the workpiece can be damaged by excessive lubrication.

1. Disconnect the tool from the air supply.
2. Turn the tool so the air inlet is facing up. Place 4 – 5 drops of air tool oil into the air inlet.
3. Connect the tool to the air supply as instructed below. Load fasteners as instructed below. Fire the tool 3 – 4 times into a piece of scrap wood to lubricate the internal parts of the tool. Wipe off any excess oil from the exhaust cap and the air inlet.

CONNECTING THE TOOL TO AN AIR SUPPLY

Your tool should be connected to a properly installed compressed air supply. The working pressure of the air compressor must be regulated to fit the operating pressure of your nailer (60 – 100 PSI). Refer to (Fig. 1) for the recommended accessories and connection configuration.

⚠ WARNING! Make sure the nailer magazine is empty and the tip of the nailer is pointed away from you when connecting to the air supply. To reduce the risk of misfires, connect the air supply **BEFORE** loading fasteners. Make sure the nailer magazine is empty when connecting the air supply. Never aim the tip of the nailer towards yourself or others.

⚠ WARNING! Use only clean, dry, and regulated air. Do not use bottled gases to power this tool. There is a risk of explosion, and serious personal injury may result. Do not operate when the air pressure is outside of the recommended range (60 to 100 PSI).

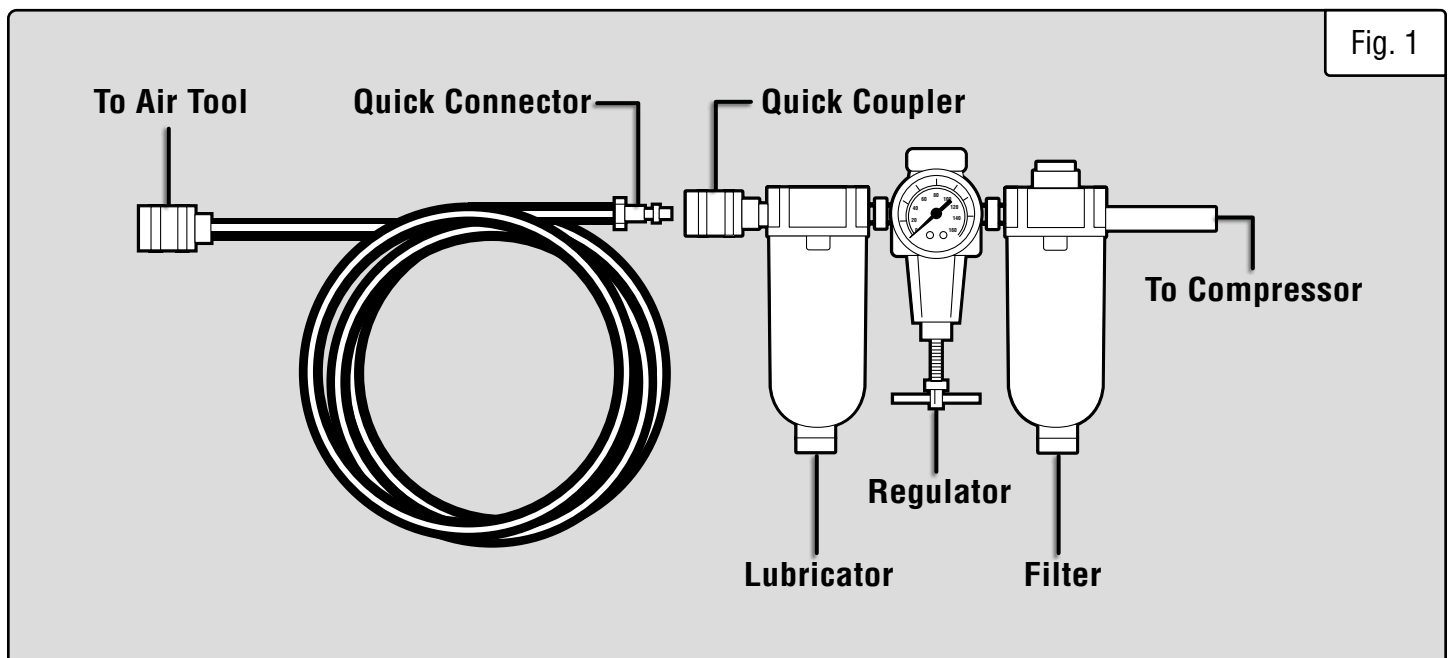

PREPARATIONS & ADJUSTMENTS

1. Turn the compressor on and allow it to pressurize. Make sure the tool pressure regulator is set to 0 (Fig. 2).
2. Connect the air hose to the outlet of your air compressor. Connect the other end of the air hose to the air inlet of the nailer. The connections must click into place audibly. Use appropriate hose tape to prevent leaking.
3. On the air compressor, set the tool pressure regulator to the proper pressure (60 – 100 PSI). The pressure can be adjusted later depending on firing depth, fastener length, and workpiece hardness.
4. To disconnect the tool from the air hose, pull back the ring on the quick connector to release the connection. Do the same to disconnect the air hose from the air compressor.

LOADING FASTENERS

⚠ WARNING! Always load the fasteners AFTER connecting the air supply to reduce the risk of misfires. Never aim the tip of the nailer at yourself or others.

1. Depress the magazine lock (Fig. 2 - 1). Pull out the movable magazine (Fig. 2 - 2).
2. Hold the nailer with the magazine at your side. Make sure the tip is pointed away from yourself or others.
3. Your nailer is designed to work with 18-gauge brad nails 3/8" to 2" long. Up to 100 fasteners may be loaded in the magazine.

- **Loading nails:** Place a clip of nails into the grooves of the fixed magazine, with the nail tips pointing downwards. Make sure the nail tips are against the bottom of the magazine, and the nail heads rest on the appropriate groove of the fixed magazine track (Fig. 3).

4. Push the movable magazine forward until it clicks shut. Make sure it is locked in place.

NOTE: Some force may be required to fully close the magazine when fasteners are loaded.

NOTE: Regularly check the fastener gauge window, and load more fasteners as necessary. Dry-firing the tool can damage it, and may leave unwanted marks on your workpiece.

ADJUSTING THE AIR EXHAUST CAP

Air is released through the air exhaust cap during operation. Rotate the adjustable cap (Fig. 3 - 1) to direct the released air in your preferred direction, away from you and your workpiece.

NO-MAR TIP

A rubber no-mar tip is attached to your tool's safety bracket to reduce marring and damage to workpiece during operation. Make sure to disconnect the tool from the air supply before adjusting, removing or installing the no-mar tip.

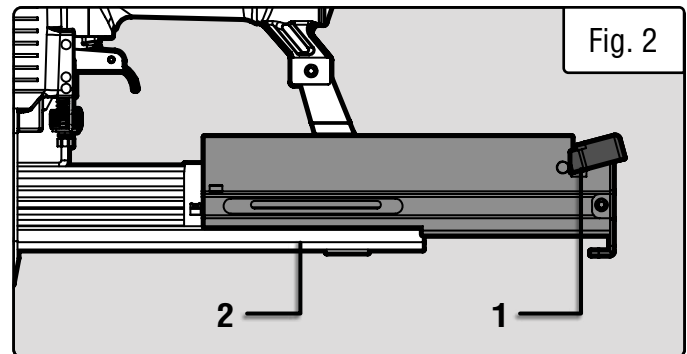

Fig. 2

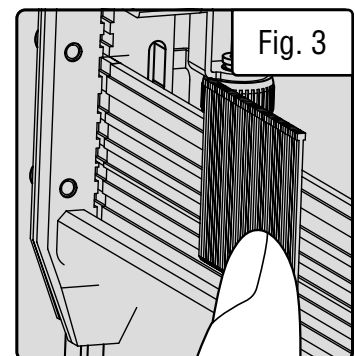

Fig. 3

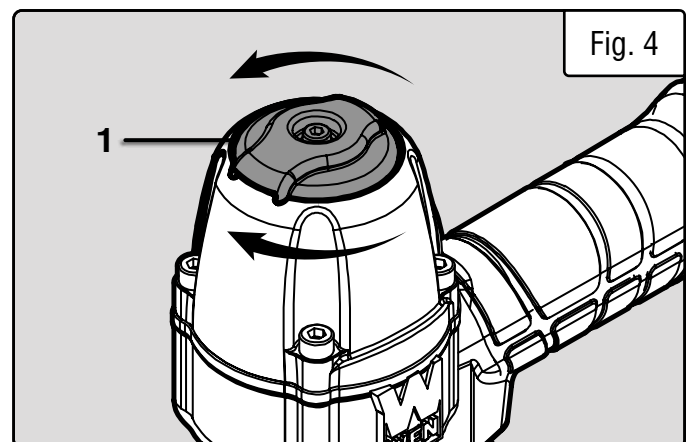

Fig. 4

OPERATION

⚠ WARNING! Before each use, check the nailer, compressed air connections, and air lines. If any parts are missing or damaged, do not operate this tool until the parts are repaired and/or replaced. Failure to do so may result in serious personal injury.

ADJUSTING THE DEPTH-ADJUSTMENT WHEEL

The tool is equipped with a depth-adjustment wheel (Fig. 5 - 1) to set the penetration depth of the fasteners. Experiment on a piece of scrap wood to find the proper depth for your workpiece, air pressure, fastener length, etc.

- Turn the wheel clockwise to increase the firing depth.
- Turn the wheel counterclockwise to decrease the firing depth.

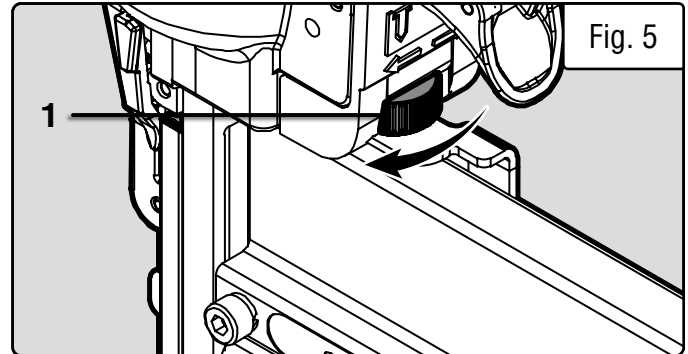

FIRING FASTENERS

⚠ WARNING! Using this type of tool can be dangerous. To reduce the risk of injury, always wear proper eye and hearing protection when operating this tool. Stay alert and keep proper balance at all times. Always release the trigger when not operating the tool to reduce the risk of unintended fastener discharge.

1. Check that the air supply is securely connected to the tool, set to the correct pressure, and the fasteners have been loaded into the magazine.

2. Test the driving depth on a scrap piece of wood. If the fasteners penetrate too deeply, decrease the firing depth, or adjust the regulator to lower air pressure. If the fasteners penetrate too shallowly, increase the firing depth, or adjust the regulator to higher air pressure. Try to adjust both the air pressure regulator and the depth wheel so that you can achieve your desired firing depth with the lowest possible air pressure. This will save energy, reduce noise, and reduce wear on the tool.

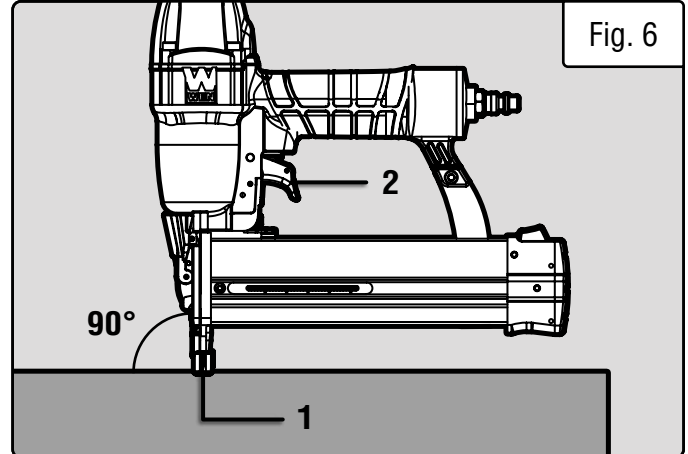

3. Hold the nailer upright on the workpiece and position the no-mar tip where the fastener will be driven (Fig. 6).

4. Carefully press down on the safety bracket (Fig. 6 - 1) and pull the trigger (Fig. 6 - 2) to drive a fastener.

5. Release the trigger, lift the tool off the workpiece and reposition it where the next fastener will be driven. Repeat step 4 to drive another fastener.

6. Regularly check the fastener gauge window, and load more fasteners as necessary. Dry-firing the tool can damage it, and may leave unwanted marks on your workpiece.

WARNING: If the safety bracket is not functioning as described above, stop using the tool immediately and disconnect it from the air supply.

7. After operation, turn off the air compressor and depressurize the compressor according to the instructions included with your compressor. Disconnect the air hose from the nailer. Remove fasteners from the nailer.

OPERATION

DRIVING MODES

Your nailer has two driving modes: single-sequential and bump-fire. For details, see below.

Single-sequential:

1. Press the safety bracket against the workpiece.
2. Pull the trigger. A fastener is fired.
3. Remove the safety bracket from the workpiece. Re-position the tool. Repeat steps 1 – 3.

Bump-fire:

1. Pull the trigger.
2. Press the safety bracket against the workpiece. A fastener is fired.
3. Remove the safety bracket from the workpiece. Re-position the tool. Repeat steps 1 - 3.

CLEARING JAMMED FASTENERS

 **WARNING!** Disconnect air line from the tool and remove all other fasteners before removing jammed fasteners, in order to avoid personal injury. Keep the tool pointed away from yourself and others.

1. Disconnect the tool from the air supply. Open the magazine and remove all other fasteners from the magazine.
2. Flip open the jam-clearing latch, and pull up to open the front plate. Remove the jammed fastener, using pliers or another tool if necessary.
3. If the piston assembly is in the down position, insert a screwdriver or other rod into the nosepiece and push the piston back in position.
4. Close the front plate. Push down latch cover to secure the front plate to the nosepiece. Make sure the trigger and safety bracket move freely without sticking or binding.
5. Connect the nailer to the air supply. Load fasteners. Test-fire the nailer into a piece of scrap wood to make sure it is operating properly.

MAINTENANCE

 **WARNING!** Disconnect tool from air supply and empty fasteners from the magazine before performing any cleaning or maintenance.

LUBRICATION

Routine lubrication of the tool is required for best performance. If the tool is used without an in-line oiler, place 3 – 4 drops of pneumatic tool oil into the air inlet of the tool at the beginning of each workday. This will ensure the moving components, seals, and O-rings are properly lubricated.

COMPRESSOR

Follow the maintenance schedule recommended in your air compressor's owner's manual. Regularly check the air filter and drain the tank at least weekly. This will help keep water and other contaminants from entering your nailer.

CLEANING

Keep tools clean for better and safer performance. Wipe the tool clean with a damp towel and mild soap. Blow the tool clean using compressed air, then use non-flammable cleaning solutions to wipe exterior of the tool as necessary. Do not soak tool with cleaning solutions. Such solutions can damage internal parts.

INSPECTION

1. Inspect trigger and safety mechanism to assure system is complete and functional (no loose or missing parts, no binding or sticking parts). Do not operate if any portion of the tool, trigger, or safety bracket is damaged, inoperable, disconnected, or altered. Leaking air, damaged parts, or missing parts should be repaired or replaced before use.

2. Keep all screws tight. Loose screws can cause personal injury or damage the tool.

3. Dirt, water, and other contaminants in the air supply are major causes of pneumatic tool wear. Follow the compressor instructions to check the compressor's air filter and to drain the compressor's tank regularly.

STORAGE

Place the tool and accessories inside the blow mold case to protect it from dust and moisture. Store the unit and accessories in a dark, dry, frost-free and well ventilated place, out of the reach of children. The ideal storage temperature is between 50 to 86 °F (10 and 30 °C).

PRODUCT DISPOSAL

Used pneumatic tools contain recyclable materials and should not be disposed with household waste. Please take this product to your local recycling facility for responsible disposal and to minimize its environmental impact.

TROUBLESHOOTING GUIDE

⚠ WARNING! Stop using the tool immediately if any of the following problems occur. Repairs and replacements should only be performed by an authorized technician. For any questions, please contact our customer service at **1-847-429-9263**, M-F 8-5 CST or email us at techsupport@wenproducts.com.

PROBLEM	CAUSE	SOLUTION
Air leaking at trigger area	1. O-ring in trigger valve is damaged.	1. Check and replace O-ring.
	2. Trigger valve head is damaged.	2. Check and replace trigger valve head.
	3. Trigger valve stem, seal or O-ring is damaged.	3. Check and replace trigger valve stem, seal or O-ring.
Air leaking between body and drive guide	1. Damaged piston O-ring or bumper.	1. Check and replace O-ring or bumper.
Air leaking between body and cylinder cap	1. Screw loose.	1. Tighten screws.
	2. Damaged gasket.	2. Check and replace seal.
Blade driving fastener too deeply	1. Worn bumper.	1. Replace bumper.
	2. Air pressure is too high.	2. Adjust the air pressure.
Runs slowly or has power loss	1. Insufficient oil.	1. Lubricate as instructed.
	2. Insufficient air supply.	2. Check air supply.
	3. Broken spring in cylinder cap.	3. Replace spring.
	4. Exhaust port in cylinder cap is blocked.	4. Replace damaged internal parts.
Tool skips a fastener	1. Worn bumper or damaged spring.	1. Replace bumper or pusher spring.
	2. Dirt in drive guide.	2. Clean drive channel of front plate.
	3. Inadequate airflow to tool.	3. Check hose and compressor fittings.
	4. Worn or dry O-ring on piston.	4. Replace O-ring or lubricate.
	5. Damaged O-ring on trigger valve.	5. Replace O-ring.
	6. Cylinder cap seal leaking.	6. Replace seal.
Fasteners are jammed	1. Joint guider is worn.	1. Replace joint guider.
	2. Fasteners are wrong size or damaged.	2. Use the recommended and undamaged fasteners.
	3. Magazine or front plate screws are loose.	3. Tighten screws.
	4. Blade in piston assembly is damaged.	4. Replace piston assembly.
Tool will not drive down tight	1. Worn blade in piston assembly.	1. Replace piston assembly.
	2. Lack of power.	2. Adjust to adequate air pressure.
	3. Slow cycling and loss of power.	3. Check cylinder cap spring for broken coils or reduced length. Check if exhaust port of cylinder cap is restricted.

EXPLODED VIEW & PARTS LIST

No.	Part No.	Description	Qty.
1	61720-001	Screw	1
2	61720-002	Bushing	1
3	61720-004	Washer	1
4	61721-004	Bushing Washer	1
5	61721-005	Screw	1
6	61721-006	Washer	1
7	61721-007	Cylinder Cap	1
8	61721-008	Gasket	1
9	61720-010	Seal	1
10	61721-010	Spring	1
11	61720-015	Valve	1
12	61720-012	O-Ring	1
13	61720-013	O-Ring	1
14	61720-014	O-Ring	1
15	61720-016	Stop Washer	1
16	61720-018	Collar	1
17	61720-017	O-Ring	1
18	61721-018	Cylinder	1
19	61720-021	O-Ring	1
20	61721-020	O-Ring	1
21	61720-019	O-Ring	1
22	61721-022	Piston Assembly	1
23	61721-023	Bumper	1
24	61721-024	Body	1
25	61720-025	Seal	1
26	61721-026	Safe Guide	1
27	61720-031	Spring Pin	1
28	61721-028	Spring	1
29	61721-029	Safety Bracket A	1
30	61721-030	Safety Bracket B	1
31	61721-031	Bushing	1
32	61721-032	Washer	1
33	61720-061	Screw	1
34	61721-034	Rubber Cover	1
35	61720-032	O-Ring	1
36	61720-033	Trigger Valve Head	1
37	61720-034	Spring	1
38	61720-035	O-Ring	1
39	61721-039	Trigger Valve Stem	1

No.	Part No.	Description	Qty.
40	61720-038	Trigger Valve Guide	1
41	61720-037	O-Ring	1
42	61721-042	Spring	1
43	61720-044	Washer	1
44	61721-044	Trigger Assembly	1
45	61720-042	Trigger Pin	1
46	61721-046	Latch Assembly	1
47	61721-047	Latch Cover	1
48	61721-048	Pin	1
49	61721-049	Plate	1
50	61721-050	Pin	1
51	61721-051	Rail	1
52	61720-046	Screw	1
53	61721-053	Front Plate	1
54	61721-054	Drive Guide	1
55	61721-055	Fixed Magazine	1
56	61721-056	Feeder Shoe	1
57	61721-057	Feeder Set	1
58	61720-059	Spring	1
59	61721-059	Movable Magazine	1
60	61721-060	Stop Plate	1
61	61720-068	Screw	1
62	61721-062	Screw	1
63	61721-063	Joint Guide	1
64	61721-064	Bushing	1
65	61721-065	Spring	1
66	61721-066	Lock	1
67	61721-067	Nut	1
68	61721-068	Washer	1
69	61721-069	Screw	1
70	61721-070	Screw	1
71	61721-071	Support	1
72	61721-072	Nut	1
73	61721-073	Soft Grip Sleeve	1
74	61720-070	O-Ring	1
75	61721-075	End Cap	1
76	61720-072	Air Plug	1

WARRANTY STATEMENT

WEN Products is committed to building tools that are dependable for years. Our warranties are consistent with this commitment and our dedication to quality.

LIMITED WARRANTY OF WEN PRODUCTS FOR HOME USE

GREAT LAKES TECHNOLOGIES, LLC (“Seller”) warrants to the original purchaser only, that all WEN consumer power tools will be free from defects in material or workmanship during personal use for a period of two (2) years from date of purchase or 500 hours of use; whichever comes first. Ninety days for all WEN products if the tool is used for professional or commercial use. Purchaser has 30 days from the date of purchase to report missing or damaged parts.

SELLER’S SOLE OBLIGATION AND YOUR EXCLUSIVE REMEDY under this Limited Warranty and, to the extent permitted by law, any warranty or condition implied by law, shall be the replacement of parts, without charge, which are defective in material or workmanship and which have not been subjected to misuse, alteration, careless handling, misrepair, abuse, neglect, normal wear and tear, improper maintenance, or other conditions adversely affecting the Product or the component of the Product, whether by accident or intentionally, by persons other than Seller. To make a claim under this Limited Warranty, you must make sure to keep a copy of your proof of purchase that clearly defines the Date of Purchase (month and year) and the Place of Purchase. Place of Purchase must be a direct vendor of Great Lakes Technologies, LLC. Purchasing through third party vendors, including but not limited to garage sales, pawn shops, resale shops, or any other secondhand merchant, voids the warranty included with this product. Contact techsupport@wenproducts.com or 1-800-232-1195 with the following information to make arrangements: your shipping address, phone number, serial number, required part numbers, and proof of purchase. Damaged or defective parts and products may need to be sent to WEN before the replacements can be shipped out.

Upon the confirmation of a WEN representative, your product may qualify for repairs and service work. When returning a product for warranty service, the shipping charges must be prepaid by the purchaser. The product must be shipped in its original container (or an equivalent), properly packed to withstand the hazards of shipment. The product must be fully insured with a copy of the proof of purchase enclosed. There must also be a description of the problem in order to help our repairs department diagnose and fix the issue. Repairs will be made and the product will be returned and shipped back to the purchaser at no charge for addresses within the contiguous United States.

THIS LIMITED WARRANTY DOES NOT APPLY TO ITEMS THAT WEAR OUT FROM REGULAR USAGE OVER TIME, INCLUDING BELTS, BRUSHES, BLADES, BATTERIES, ETC. ANY IMPLIED WARRANTIES SHALL BE LIMITED IN DURATION TO TWO (2) YEARS FROM DATE OF PURCHASE. SOME STATES IN THE U.S. AND SOME CANADIAN PROVINCES DO NOT ALLOW LIMITATIONS ON HOW LONG AN IMPLIED WARRANTY LASTS, SO THE ABOVE LIMITATION MAY NOT APPLY TO YOU.

IN NO EVENT SHALL SELLER BE LIABLE FOR ANY INCIDENTAL OR CONSEQUENTIAL DAMAGES (INCLUDING BUT NOT LIMITED TO LIABILITY FOR LOSS OF PROFITS) ARISING FROM THE SALE OR USE OF THIS PRODUCT. SOME STATES IN THE U.S. AND SOME CANADIAN PROVINCES DO NOT ALLOW THE EXCLUSION OR LIMITATION OF INCIDENTAL OR CONSEQUENTIAL DAMAGES, SO THE ABOVE LIMITATION OR EXCLUSION MAY NOT APPLY TO YOU.

THIS LIMITED WARRANTY GIVES YOU SPECIFIC LEGAL RIGHTS, AND YOU MAY ALSO HAVE OTHER RIGHTS WHICH VARY FROM STATE TO STATE IN THE U.S., PROVINCE TO PROVINCE IN CANADA AND FROM COUNTRY TO COUNTRY.

THIS LIMITED WARRANTY APPLIES ONLY TO ITEMS SOLD WITHIN THE UNITED STATES OF AMERICA, CANADA AND THE COMMONWEALTH OF PUERTO RICO. FOR WARRANTY COVERAGE WITHIN OTHER COUNTRIES, CONTACT THE WEN CUSTOMER SUPPORT LINE. FOR WARRANTY PARTS OR PRODUCTS REPAIRED UNDER WARRANTY SHIPPING TO ADDRESSES OUTSIDE OF THE CONTIGUOUS UNITED STATES, ADDITIONAL SHIPPING CHARGES MAY APPLY.