

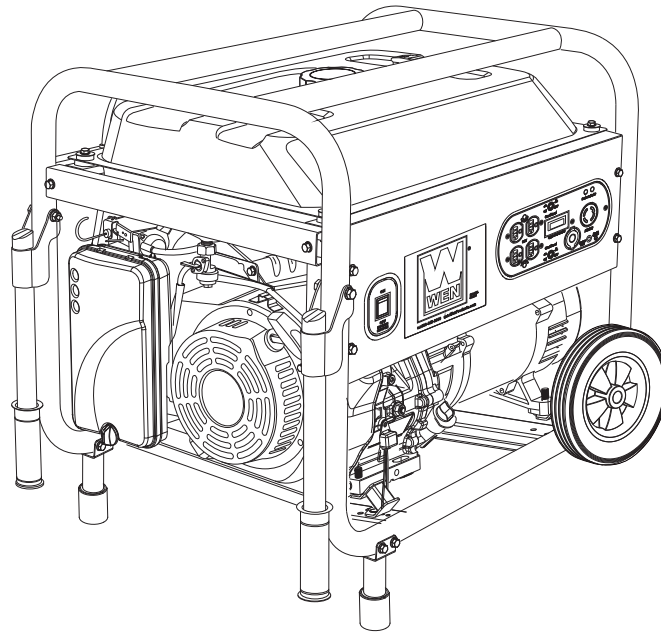

5500W PORTABLE GENERATOR



Model # 56551
bit.ly/WENvideo

IMPORTANT:

Your new tool has been engineered and manufactured to WEN's highest standards for dependability, ease of operation, and operator safety. When properly cared for, this product will supply you years of rugged, trouble-free performance. Pay close attention to the rules for safe operation, warnings, and cautions. If you use your tool properly and for intended purpose, you will enjoy years of safe, reliable service.

NEED HELP? CONTACT US!

Have product questions? Need technical support?
Please feel free to contact us at:

 **800-232-1195** (M-F 8AM-5PM CST)

 **techsupport@wenproducts.com**

 **WENPRODUCTS.COM**



TABLE OF CONTENTS

Generator Identification.....	3
Service Record	3
Introduction	4
Safety Information	4
Know Your Generator	7
Assembly	8
Generator Preparation	10
Starting the Generator	12
Stopping the Generator	13
Subsequent Starting of the Generator	14
Using the Generator	15
Maintenance & Care	17
Storage & Transport	23
Specifications	24
Troubleshooting	25
Exploded View and Parts List	26
Wiring Diagram	32
Warranty Statement	33

GENERATOR IDENTIFICATION

If assistance for information or service is required, please contact the Customer Service Help Line by calling 800-232-1195; customer will be asked to provide generator information when calling.

Refer to the illustration below for the location of the serial number. Record generator information in the spaces provided below.

GENERATOR MODEL NUMBER: 56475

DATE OF PURCHASE: _____

PURCHASED FROM: _____

ENGINE SERIAL NUMBER: _____

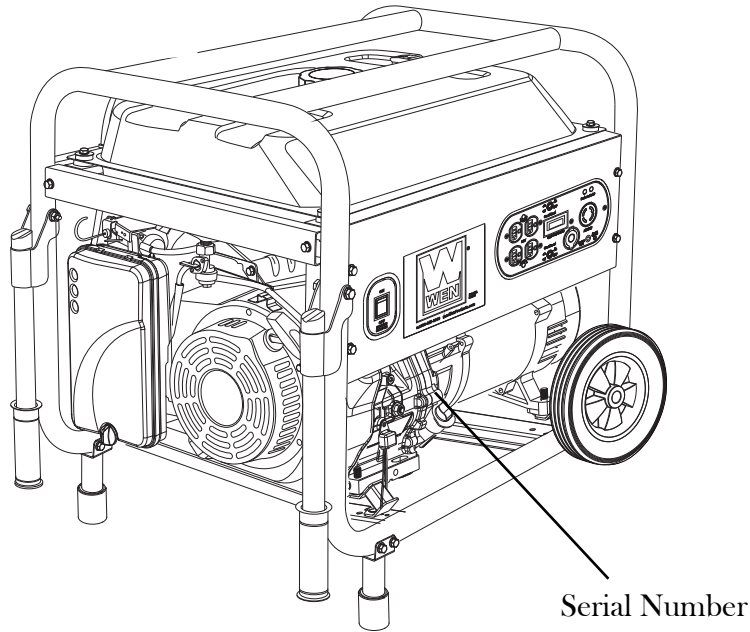

SERVICE RECORD

Record Service Dates:

	Date	Date	Date	Date	Date	Date
Change Oil						
Change Spark Plug						
Clean Fuel Tank						
Clean Air Filter						

TO MAXIMIZE THE LIFESPAN OF THIS GENERATOR, MAKE SURE TO RUN IT AT LEAST ONCE A MONTH. IF YOU DO NOT RUN IT OFTEN, IT WILL GREATLY SHORTEN THE LIFESPAN AND PERFORMANCE OF THE GENERATOR.

INTRODUCTION

Thank you for purchasing a WEN Generator. This manual provides information regarding the safe operation and maintenance of this product. Every effort has been made to ensure the accuracy of the information in this manual. WEN reserves the right to change this product, manual and specifications at any time without prior notice.

Please keep this manual available to all users during the entire life of the generator.



This manual contains special messages to bring attention to potential safety concerns and generator damage as well as helpful operating and servicing information. Please read all the information carefully to avoid injury and machine damage.

QUESTIONS? PROBLEMS?

In order to answer questions and solve problems in the most efficient and speedy manner, contact Customer Service at (800) 232-1195, M-F 8-5 CST

NOTICE REGARDING EMISSIONS

Engines that are certified to comply with U.S. EPA emission regulations for SORE (Small Off Road Equipment), are certified to operate on regular unleaded gasoline, and may include the following emission control systems: (EM) Engine Modifications and (TWC) Three-Way Catalyst (if so equipped).

SAFETY INFORMATION

Before operating this generator read and observe all warnings, cautions, and instructions both on the generator and in this owner's manual.

NOTE: The following safety information is not meant to cover all possible conditions and situations that may occur.

This safety alert symbol is used to identify safety information about hazards that can result in personal injury.



A signal word (**DANGER**, **WARNING**, or **CAUTION**) is used with the alert symbol to indicate the likelihood and the potential severity of injury. In addition, a hazard symbol may be used to represent the type of hazard.

DANGER indicates a hazard, which, if not avoided, will result in death or serious injury.

WARNING indicates a hazard, which, if not avoided, could result in death or serious injury.

CAUTION indicates a hazard, which, if not avoided, might result in minor or moderate injury.

CAUTION when used without the alert symbol, indicates a situation that could result in damage to the engine or generator.

SAFETY INFORMATION

For any questions regarding the hazard and safety notices listed in this manual or on the product, please call (800) 232-1195 M-F 8-5 CST before using the generator.



DANGER: CARBON MONOXIDE

Using a generator indoors **CAN KILL YOU IN MINUTES**. Generator exhaust contains carbon monoxide (CO). This is a poison gas you cannot see or smell. If you can smell the generator exhaust, you are breathing CO. But even if you cannot smell the exhaust, you could be breathing CO.

NEVER use a generator inside homes, garages, crawl spaces, or other partially enclosed areas. Deadly levels of carbon monoxide can build up in these areas. Using a fan or opening windows and doors does **NOT** supply enough fresh air. **ONLY** use a generator outside and far away from windows, doors, and vents. These openings can pull in generator exhaust.

Even if you use a generator correctly, CO may leak into the home. **ALWAYS** use a battery-powered or battery-backup CO alarm in the home. If you start to feel sick, dizzy, or weak after the generator has been running, move to fresh air **RIGHT AWAY**. See a doctor. You may have carbon monoxide poisoning.



WARNING: The exhaust from this product contains chemicals known to the State of California to cause cancer, birth defects, or other reproductive harm.



WARNING: This generator may emit highly flammable and explosive gasoline vapors, which can cause severe burns or even death if ignited. A nearby open flame can lead to explosion even if it isn't directly in contact with gasoline.

GENERATOR SAFETY RULES:

- 1) Do not operate near open flame.
- 2) Do not smoke near generator.
- 3) Always operate on a firm, level surface.
- 4) Always turn generator off before refueling. Allow generator to cool for at least 2 minutes before removing fuel cap. Loosen cap slowly to relieve pressure in tank.
- 5) Do not overfill fuel tank. Gasoline may expand during operation. Do not fill to the top of the tank. Allow for expansion.
- 6) Always check for spilled fuel before operating.
- 7) Empty fuel tank before storing or transporting the generator.
- 8) Do not use in rainy conditions.
- 9) **ALWAYS** ground the generator before using it (see the "Ground the Generator" portion of the "Generator Preparation" section).
- 10) Generator should only be plugged into electrical devices, either directly or with an extension cord. **NEVER** connect to a building's electrical system without a qualified electrician. Such connections must comply with local electrical laws and codes. Failure to comply can create a back-feed, which may result in serious injury or death to utility workers.
- 11) Use a ground fault circuit interrupter (GFCI) in highly conductive areas such as metal decking or steel work. GFCIs are available in-line with some extension cords.
- 12) Do not touch bare wires or receptacles (outlets).
- 13) Do not allow children or non-qualified persons to operate the generator.

SAFETY INFORMATION

GENERATOR SAFETY RULES (CONTINUED):

- 14) Do not touch hot surfaces. Pay attention to warning labels on the generator identifying hot parts of the machine.
- 15) Allow generator to cool down after use before touching engine or areas of the generator that become hot during use.
- 16) Only use generator for its intended purposes.
- 17) Operate only on dry, level surfaces.
- 18) Allow generator to run for several minutes before connecting electrical devices.
- 19) Shut off and disconnect any malfunctioning devices from generator.
- 20) Do not exceed the wattage capacity of the generator by plugging in more electrical devices than the unit can handle.
- 21) Do not turn on electrical devices until after they are connected to the generator.
- 22) Turn off all connected electrical devices before stopping the generator.
- 23) Turn the engine switch to "OFF" position when the engine is not running.

CAUTION: Misuse of this generator can damage it or shorten its life.



WARNING: This generator produces heat when running. Temperatures near exhaust can exceed 150° F (65° C).

SAVE THESE INSTRUCTIONS - This manual contains important instructions for the WEN generator that should be followed during installation and maintenance of the generator.

Generators vibrate in normal use. During and after the use of the generator, inspect both the generator as well as extension and power supply cords for damage resulting from vibration. Have damaged items repaired or replaced as necessary. Do not use plugs or cords that show signs of damage such as broken or cracked insulation.

For power outages, permanently installed stationary generators are better suited for providing backup power to the home. Even a properly connected portable generator can become overloaded. This may result in overheating or stressing of the components, possibly leading to a generator failure.



WARNING: If this generator is used as a supply for a building's wiring system, the generator must be installed by a qualified electrician and connected to a transfer switch as a separately derived system in accordance with the National Electrical Code, NFPA 70. The generator shall be connected to a transfer switch that switches all conductors excluding the equipment grounding conductor. The frame of the generator shall be connected to an approved grounding electrode.

KNOW YOUR GENERATOR

Use the illustrations below to become familiar with the locations and functions of the various components and controls of this generator.

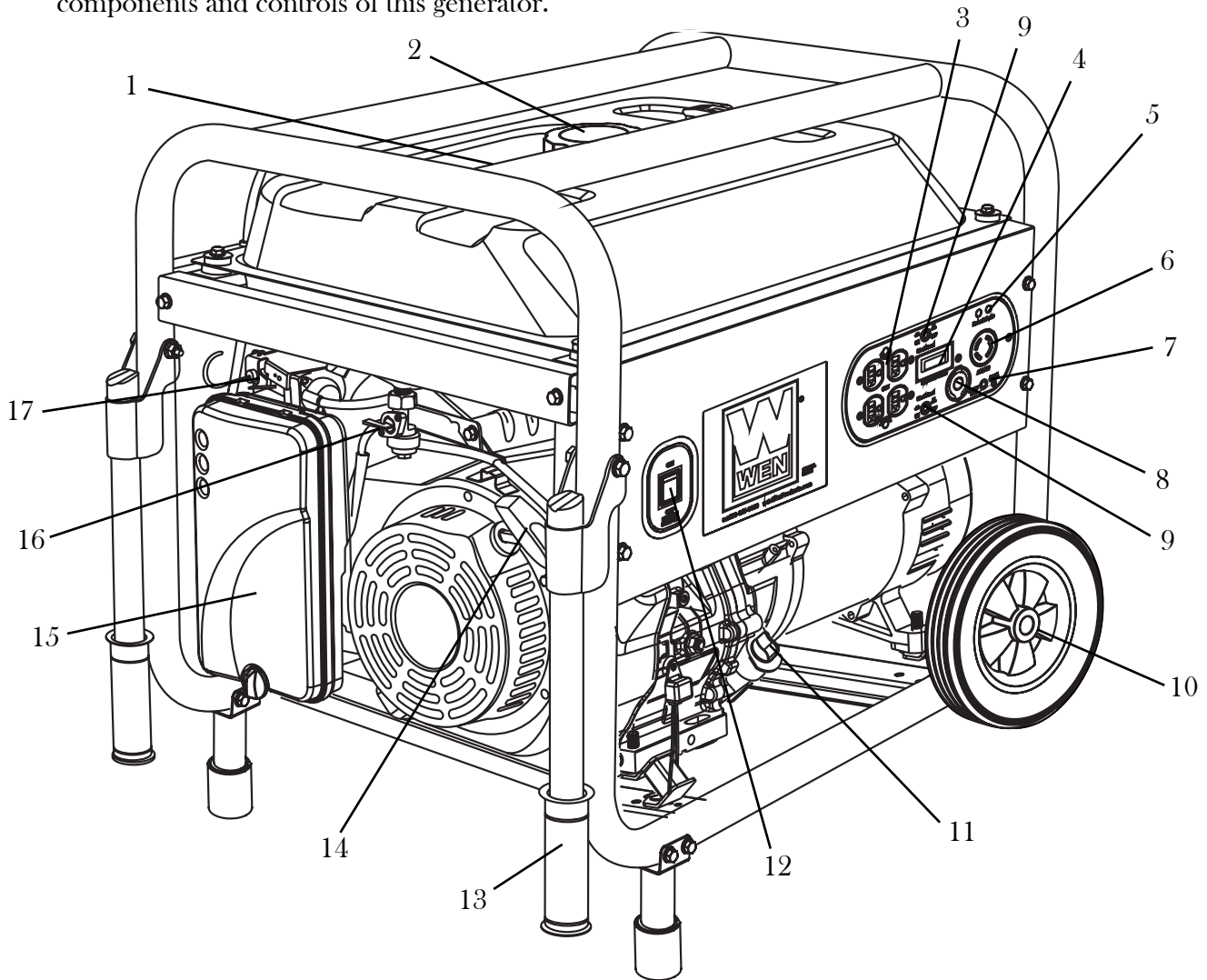

- 1 **Fuel Gauge** - indicates the amount of fuel in the tank
- 2 **Fuel Cap** - access to the fuel tank for adding gasoline
- 3 **120V AC Duplex Receptacle** - to connect electrical devices that run 120V, 60 Hz, single phase AC current.
- 4 **Digital Engine Hour Counter**
- 5 **Power Indicator** - turns green to indicate the output of power to each receptacle
- 6 **240/120V AC Receptacle** - To connect electrical devices that run 120V and/or 240V, 60 Hz, single phase, AC current.
- 7 **Grounding Nut**
- 8 **12V Cigarette Lighter DC Receptacle**
- 9 **Circuit Reset Buttons** - circuit breakers that prevent the generator from electrical overload.
- 10 **8-Inch Wheels** - for easy transport
- 11 **Oil Fill and Dipstick** - Location for checking and filling the oil reservoir
- 12 **Engine Switch** - Start and stop the engine
- 13 **Handles** - for easy transport
- 14 **Recoil Starter** - Pull cord for starting the engine
- 15 **Air Cleaner** - a removable, cleanable sponge-like element that limits the amount of dirt pulled into the engine.
- 16 **Fuel Valve** - Allows fuel to enter the engine
- 17 **Choke Lever**

ASSEMBLY

For video instructions visit bit.ly/WHEELKIT

To attach the feet to the generator, perform the following steps:

1. Stack the two generator wheels on top of each other. Lift the end of the generator that has the recoil starter onto the stack of wheels. Be careful not to obstruct any holes on the generator frame. Feel free to use board or a different reliable stacking surface instead.
2. Place one leg onto the frame. Line up the holes on the generator frame with the holes on the bracket portion of the leg. Tighten using two M6x40 bolts, two M6 nuts, and the included wrench.
3. Repeat step 2 for the other generator leg.



The handles attach to the generator frame on the same side as the recoil starter (left side when facing control panel). To attach the handles to the generator frame, perform the following steps:

1. Take one handle and line up the bolt of the elbow with the hole in the frame.
2. Attach the handle in place with an M8 nut.
3. Repeat steps 1-2 for the other handle.

At this point, gently remove the two wheels from underneath the generator.

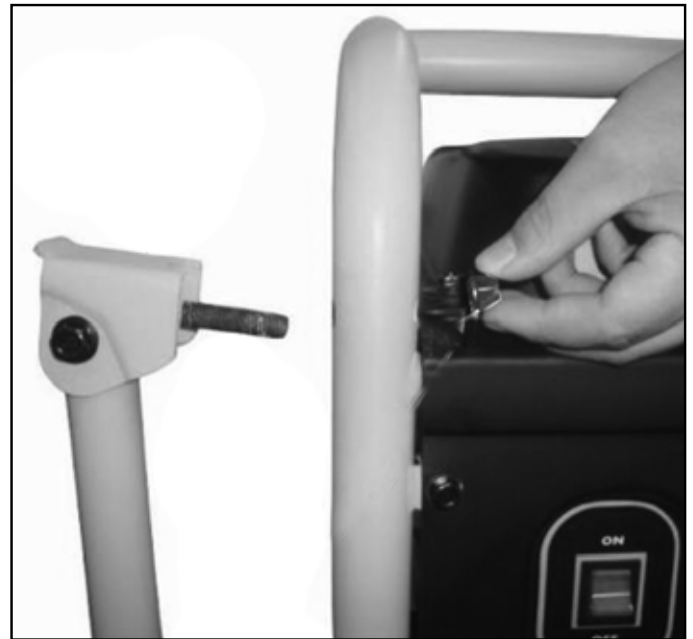

ASSEMBLY

To attach the wheels to the generator, perform the following steps:

1. Find a wood block or similar item that is 3 inches thick or greater and rest the exhaust end of the generator on the block
2. Take one wheel shaft, and one M12 nut as shown. Slide the wheel shaft, with the threaded part facing inward, through the frame. Secure using an M12 nut and the included wrench as shown.
3. Slide the wheel onto the axle and secure in place using the nut.
4. Repeat steps 2 and 3 for the other wheel.

At this point, the generator assembly is complete. Gently remove the generator from the wood block.

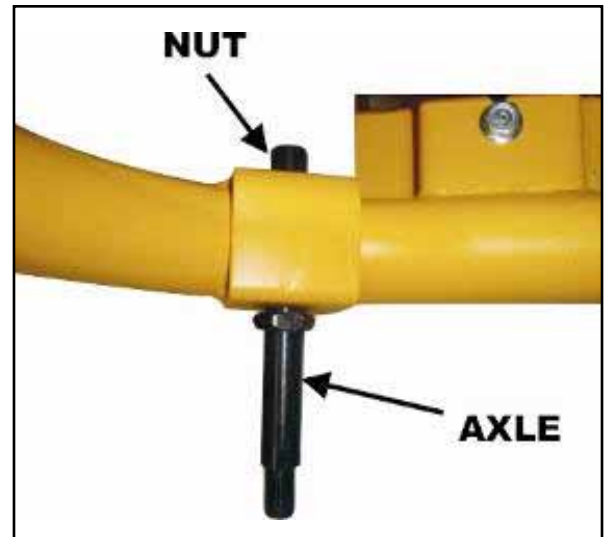
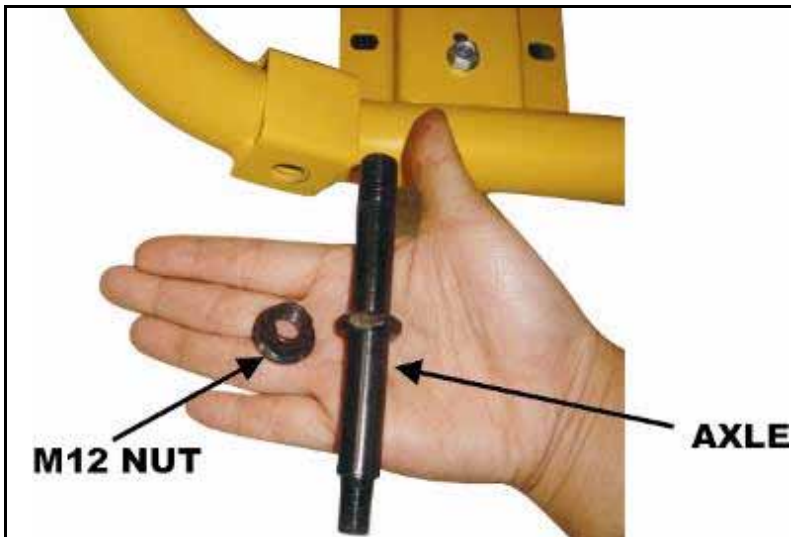
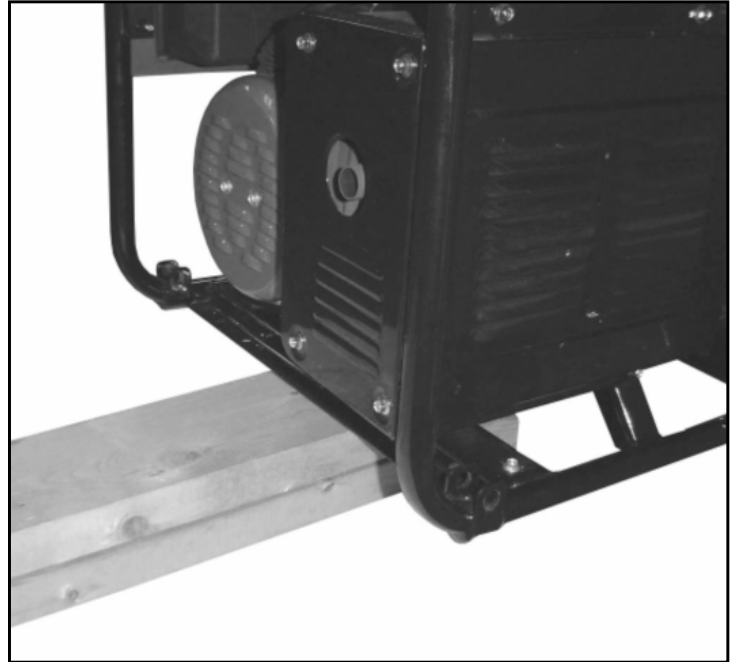

GENERATOR PREPARATION

USING THE GENERATOR FOR THE FIRST TIME

CAUTION: The following section describes the necessary steps to prepare the generator for use. If after reading this section, you are unsure about how to perform any of the steps please call (800) 232-1195 M-F 8-5 CST for customer service. Failure to perform these steps properly can damage the generator or shorten its life.

STEP 1 - ADD OIL

The generator is shipped without oil. User must add the proper amount of oil before operating the generator for the first time. The oil capacity of the engine crankcase is 1.1 liters (37 fl. oz.). For general use (above 40° F), we recommend 30W, 4-stroke engine oil.

To add oil, follow these steps:

1. Make sure the generator is on a level surface. Tilting the generator to assist in filling will cause oil to flow into the engine areas and will cause damage. Keep the generator level!

2. Remove the dipstick from the engine (Fig. 2).

3. Add oil slowly, being careful not to overfill the unit. Fill the crank case to the upper fill line so the oil lands about halfway up the dipstick threads (Fig. 2).

4. To check the oil level, wipe the dipstick with a clean rag. Insert the dipstick into the oil fill opening without screwing it in. Remove the dipstick to check the oil mark.

5. Slowly add more oil and repeat step 4 until the oil mark reaches to the top of the dipstick (Fig. 2). Do not overfill the crankcase. The generator is equipped with a low-oil sensor and will not start without a sufficient amount of oil.

6. Check for oil leaks and firmly tighten the dipstick.

ENGINE OIL RECOMMENDATIONS

Select good quality detergent oil bearing the American Petroleum Institute (API) service classifications SJ, SL, or SM (synthetic oils may be used). Use the ASE viscosity grade of oil from the following chart (Fig. 1) that matches the starting temperature anticipated before the next oil changes.

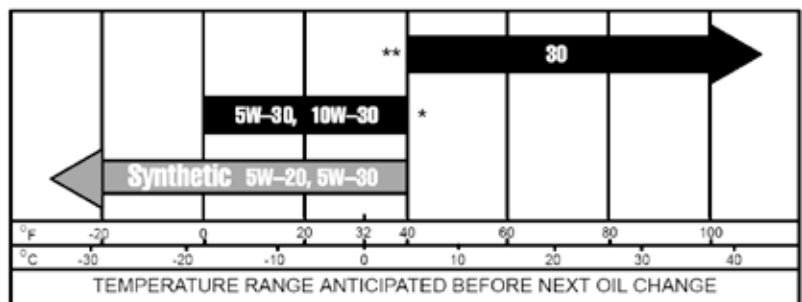

Fig. 1 - Engine Oil Temperature Recommendation

CAUTION: Air cooled engines run hotter than automotive engines. The use of non-synthetic multi-viscosity oils (5W-30, 10W-30, etc.) in temperatures above 40° F will result in higher than normal oil consumption. When using a multi-viscosity oil, check the oil level more frequently than you would otherwise.

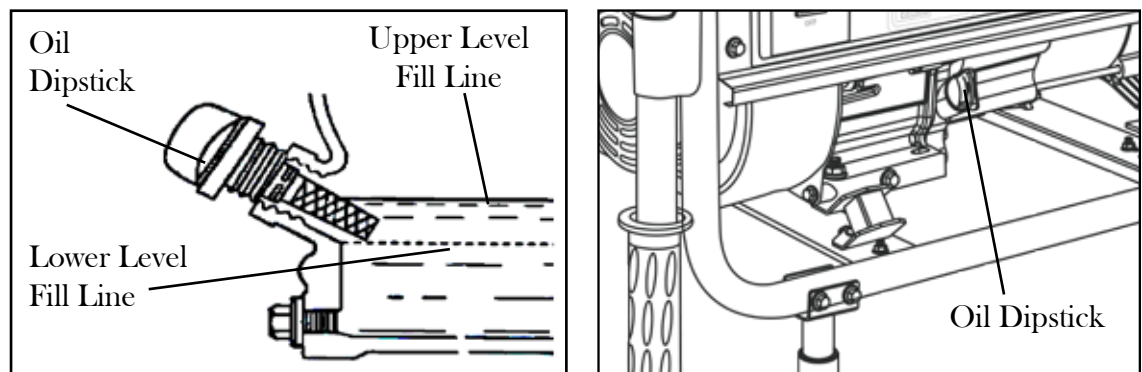

Fig. 2 - Oil Fill Opening, Dipstick and Oil Level

GENERATOR PREPARATION



WARNING: This generator may emit highly flammable and explosive gasoline vapors, which can cause severe burns or even death if ignited. A nearby open flame can lead to explosion even if not directly in contact with gasoline.

STEP 2 - ADD GASOLINE

Use fresh (within 30 days from purchase), lead-free gasoline with a minimum of 87 octane rating. Do not mix oil with gasoline.

To add gasoline, follow these steps:

1. Make sure the generator is on a level surface.
2. Unscrew fuel cap and set aside.

NOTE: The fuel cap may be tight and hard to unscrew.

3. Slowly add unleaded gasoline to the fuel tank. Be careful not to overfill. The capacity of the fuel tank is 6.5 gallons.

NOTE: Do not fill the fuel tank to the very top. Gasoline will expand and spill over during use even with the fuel cap in place.

4. Reinstall fuel cap and wipe clean any spilled gasoline with a dry cloth.

STEP 3 - GROUND THE GENERATOR

Ground the generator by tightening the grounding nut on the front control panel against a grounding wire (Fig. 3). A generally acceptable grounding wire is a No. 12 AWG (American Wire Gauge) stranded copper wire. This grounding wire should be connected at the other end to a copper, brass, or steel-grounding rod that is driven into the earth. Wire and grounding rods are not included with the generator.

Grounding codes can vary by location. Contact a local electrician to check the area codes.

NOTE: After completing the above preparation, the generator is ready to be started.



WARNING: Failure to properly ground the generator can result in electric start.

IMPORTANT:

- Never use an oil/gasoline mixture.
- Never use old gasoline.
- Avoid getting dirt or water into the fuel tank.
- Gasoline can age in the tank and make starting difficult. Never store generator for extended periods of time with fuel in the tank.

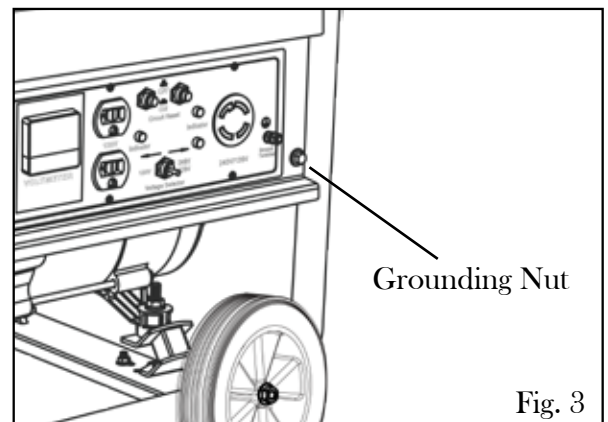

Fig. 3

STARTING THE GENERATOR

Before starting the generator, make sure you have read and performed the steps in the “Generator Preparation” section of this manual. If you are unsure about how to perform any of the steps in this manual please call (800) 232-1195 M-F 8-5 CST for customer service.



DANGER: CARBON MONOXIDE - USING A GENERATOR INDOORS CAN KILL YOU IN MINUTES.

Using a generator indoors **CAN KILL YOU IN MINUTES**. Generator exhaust contains carbon monoxide (CO). This is a poison gas you cannot see or smell. If you can smell the generator exhaust, you are breathing CO. But even if you cannot smell the exhaust, you could be breathing CO.

NEVER use a generator inside homes, garages, crawl spaces, or other partially enclosed areas. Deadly levels of carbon monoxide can build up in these areas. Using a fan or opening windows and doors does **NOT** supply enough fresh air. **ONLY** use a generator outside and far away from windows, doors, and vents. These openings can pull in generator exhaust.

Even if you use a generator correctly, CO may leak into the home. **ALWAYS** use a battery-powered or battery-backup CO alarm in the home. If you start to feel sick, dizzy, or weak after the generator has been running, move to fresh air **RIGHT AWAY**. See a doctor. You may have carbon monoxide poisoning.



WARNING: The exhaust from this product contains chemicals known to the State of California to cause cancer, birth defects, or other reproductive harm.



WARNING: This generator may emit highly flammable and explosive gasoline vapors, which can cause severe burns or even death if ignited. A nearby open flame can lead to explosion even if it isn't directly in contact with gasoline.



WARNING: This generator produces powerful voltage, which can result in electrocution.

ALWAYS ground the generator before using it (see the “Ground the Generator” portion of the “Generator Preparation” section).

Generator should only be plugged into electrical devices, either directly or with an extension cord. **NEVER** connect to a building electrical system without a qualified electrician. Such connections must comply with local electrical laws and codes. Failure to comply can create a back-feed, which may result in serious injury or death to utility workers.

Use a ground fault circuit interrupter (GFCI) in highly conductive areas such as metal decking or steel work. GFCIs are available in-line with some extension cords.

Do not use in rainy or wet conditions. Do not touch bare wires or receptacles (outlets). Do not allow children or non-qualified persons to operate.

CAUTION: Disconnect all electrical loads from the generator before attempting to start or stop.

STARTING THE GENERATOR

STARTING THE ENGINE

1. Unplug all electrical devices from the generator during ignition. Otherwise it will be difficult for the engine to start.

2. Check that the generator is properly grounded (Ground the Generator - page 11).

3. Check the oil and fuel levels.

4. Turn the fuel valve to the ON position (Fig. 4).

5. Move the choke lever to the CLOSE/START position (Fig. 5).

6. Set the ON/OFF Switch to the ON position.

7. Pull on the recoil starter handle slowly until a slight resistance is felt, then pull quickly to start the engine. Pull from the side of the generator. Do not attempt to pull the recoil starter from underneath the panel. Return cord gently into the recoil starter. Never allow the cord to snap back.

8. If engine fails to start, repeat step 7. **NOTE:** After repeated failed attempts to start the engine, please consult the troubleshooting guide before attempting to start the generator. If problems persist please call (800) 232-1195, M-F 8-5 CST.

9. Once the engine has started, slowly return the choke lever all the way to the OPEN/RUN position.

10. Allow the engine to run for several minutes before attempting to connect any electrical devices. This allows the generator to stabilize its speed and temperature.

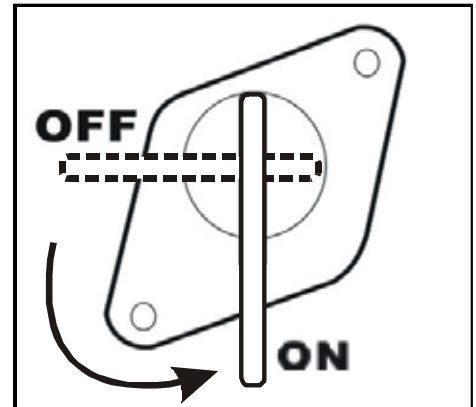

Fig. 4 - Fuel Valve

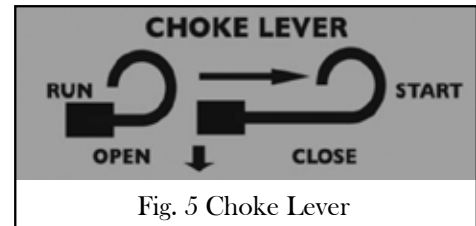

Fig. 5 Choke Lever

STOPPING THE GENERATOR

TO STOP THE GENERATOR

1. Turn off all electrical devices prior to unplugging them from the generator. Unplugging running devices can cause damage to the generator.

2. Turn the “ON/OFF” switch to the “OFF” position.

3. Turn the fuel valve to the “OFF” (horizontal) position.



WARNING: Allow the generator to cool for several minutes before touching areas that become hot during use.

CAUTION: Allowing gasoline to sit in the fuel tank for long periods of time can make it difficult to start the generator in the future. Never store the generator for extended periods of time with fuel in the fuel tank. Refer to Generator Storage Section.

SUBSEQUENT STARTING OF THE GENERATOR

If this is not the first time using the generator, the user should take the following steps to prepare it for operation.

IMPORTANT: At this point the user should be familiar with the procedures described in the sections titled “Starting the Generator” and “Generator Preparation.” If the user has not yet read these sections, go back and read them now.

STEP 1 - CHECK THE OIL

Oil consumption is normal during generator use. The generator is equipped with a low oil pressure shutoff to protect it from damage. The oil level of the engine should be checked before each use to ensure that the engine crankcase contains sufficient lubricant.

To check or add oil, follow these steps:

1. Make sure the generator is on a level surface. Clean around oil fill.
2. Remove the oil filler/dipstick cap and check the oil level.
3. If oil level is below the second thread from the lip of the oil fill opening, slowly add oil until the engine crankcase is filled.
4. Reinstall and tighten oil cap before starting the engine.

IMPORTANT:

- Use only **UNLEADED** gasoline.
- Do not use old gasoline.
- Never use an oil/gasoline mixture.
- Avoid getting dirt or water into the fuel tank.

STEP 2 - CHECK THE FUEL LEVEL

Before starting the generator, check to see that there is sufficient gasoline in the fuel tank. Add additional gasoline as necessary but leave sufficient room in the tank for expansion.

STEP 3 - GROUND THE GENERATOR



WARNING: Failure to properly ground the generator could result in electric shock.

It is suggested to ground the generator by tightening the grounding nut on the front control panel against a grounding wire (Fig. 3). A generally acceptable grounding wire is a No. 12 AWG (American Wire Gauge) stranded copper wire. This grounding wire should be connected at the other end to a copper, brass, or steel-grounding rod that is driven into the earth. Wire and grounding rod are not included in generator contents.

Grounding codes can vary by location. Contact a local electrician for area codes.

TO MAXIMIZE THE LIFESPAN OF THIS GENERATOR, MAKE SURE TO RUN IT AT LEAST ONCE A MONTH. IF YOU DO NOT RUN IT OFTEN, IT WILL GREATLY SHORTEN THE LIFESPAN AND PERFORMANCE OF THE GENERATOR.

USING THE GENERATOR

WARNING: When this generator is used on a building's wiring system, the generator must be installed by a qualified electrician and connected to a transfer switch as a separately derived system in accordance with the National Electrical Code, NFPA 70. The generator shall be connected to a transfer switch that switches all conductors other than the equipment grounding conductor. The frame of the generator shall be connected to an approved grounding electrode.

For power outages, permanently installed, stationary generators are better suited for providing backup power to the home. Even a properly connected portable generator can become overloaded. This may result in overheating or stressing the machine's components, possibly leading to a generator failure. Before connecting electrical devices, allow the generator to run for a few minutes to stabilize the speed and voltage output.

CAUTION: Become familiar with the markings on the panel before connecting electrical devices.

Connect electrical devices running on AC current according to their wattage requirements. The chart in Fig. 6 shows the rated and surge wattage of the generator. **NOTE:** Although the overall rated wattage of the machine is 3750W, it is not recommended that you attempt to draw more than 2400W (20 A) from any ONE of the 120 Volt receptacles.

The rated (running) wattage is the wattage the generator can produce on a continuous basis.

The surge wattage is the maximum amount of power the generator can produce for an extremely short period of time (seconds). Many electrical devices such as refrigerators require short bursts of extra power in addition to the rated wattage listed by the device to start their motors. The surge wattage ability of the generator covers this extra power requirement.

Item	Rated (Running) Wattage	Surge Wattage
56551	5000W	5500W

Fig. 6 - Generator Wattage

The total running wattage requirement of the electrical devices connected to the generator should not exceed the rated wattage of the generator itself. To calculate the total wattage requirement of the electrical devices you plan to connect, find the rated (or running) wattage of each device. This number should be listed somewhere on the device or in its instruction manual. If this wattage cannot be found, calculate it by multiplying the Voltage requirement by the Amperage drawn: $\text{Watts} = \text{Volts} \times \text{Amperes}$

Estimated wattages are available in Fig. 7. Do not solely rely on this chart - all electronics and appliances are built differently. These are not standard wattages across the board, only estimations.

When the rated wattage requirement of each electrical device has been determined, add these numbers to find the total rated wattage needed. If this number exceeds the rated wattage of the generator, **DO NOT** connect all these devices. Select a combination of electrical devices, which have a total rated wattage lower than or equal to the rated wattage of the generator.

CIRCUIT RESET BUTTONS help to prevent electrical overload. If your receptacle short circuits or becomes overloaded by an electrical device or devices with too great a wattage rating, the circuit protector may shut off power to the receptacle. If this happens, you will see the voltage indicator lights turn off and you will not be able to draw power from the overloaded receptacle. In the event of such an overload, disconnect all electrical devices from the generator and press the circuit reset buttons. If power still does not return to the receptacle, call our customer help line at 1-800-232-1195.

USING THE GENERATOR

CAUTION: The generator can run at its surge wattage capacity for only a short time. Connect electrical devices requiring a rated (running) wattage equal to or less than the rated wattage of the generator. Never connect devices requiring a rated wattage equal to the surge wattage of the generator. This can trip the circuit protectors (circuit breakers).

Tool or Appliance	Rated (Running) Watts	Surge (Starting) Watts
Electric water heater (40 Gal)	4000	0
Hot plate	2500	0
Saw - radial arm	2000	2000
Electric stove (each element)	1500-2800	0
Saw - circular	1500	1500
Air compressor (1 HP)	1500	3000
Window air conditioner	1200	1800
Saw - miter	1200	1200
Microwave	1000	0
Well water pump	1000	1000
Saw - reciprocating	960	1040
Sump pump	800	1200
Refrigerator freezer	800	1200
Furnace blower	800	1300
Computer	800	0
Electric drill	600	900
Television	500	0
Deep freezer	500	500
Garage door opener	480	0
Stereo	400	0
Box fan	300	600
Clock radio	300	0
Security system	180	0
DVD player / VCR	100	0
Common light bulb	75	0

Fig. 7- Estimated wattage requirements of common electrical devices

Note: The above wattage figures are estimates. Check the wattage listed on the electrical device before consulting this chart. Once the electrical devices that will be powered by the generator have been determined, connect these devices according to the following procedure:

1. Plug in each electrical device, making sure that the device is turned off.

2. Check the overload light and power indicator light. If the overload light is on, remove the plugged in load, then press the power reset button before plugging the loads back in. If the reset button does not reset, wait several minutes and try again. If the power light still does not come on, call the customer service number for further instructions.

USING THE GENERATOR

CAUTION: Do not connect 50Hz or 3-phase loads to the generator.

SOME NOTES ABOUT POWER CORDS

Long or thin cords can drain the power provided to an electrical device by the generator. When using such cords, allow for a slightly higher rated wattage requirement by the electrical device.

Device Requirements			Max. Cord Length (ft) by Wire Gauge				
Amps	Watts (120V)	Watts (240V)	#8 wire	#10 wire	#12 wire	#14 wire	#16 wire
2.5	300	600	NR	NR	NR	375	250
5	600	1200	NR	NR	300	200	125
7.5	900	1800	NR	350	200	125	100
10	1200	2400	NR	250	150	100	50
15	1800	3600	NR	150	100	65	NR
20	2400	4800	175	125	75	50	NR
25	3000	6000	150	100	60	NR	NR
30	3600	7200	125	65	NR	NR	NR
40	4800	9600	90	NR	NR	NR	NR

*NR = Not Recommended

If an overload occurs, shut down the generator. Unplug all electrical devices and wait five minutes. Then, start the unit back up again to get power back.

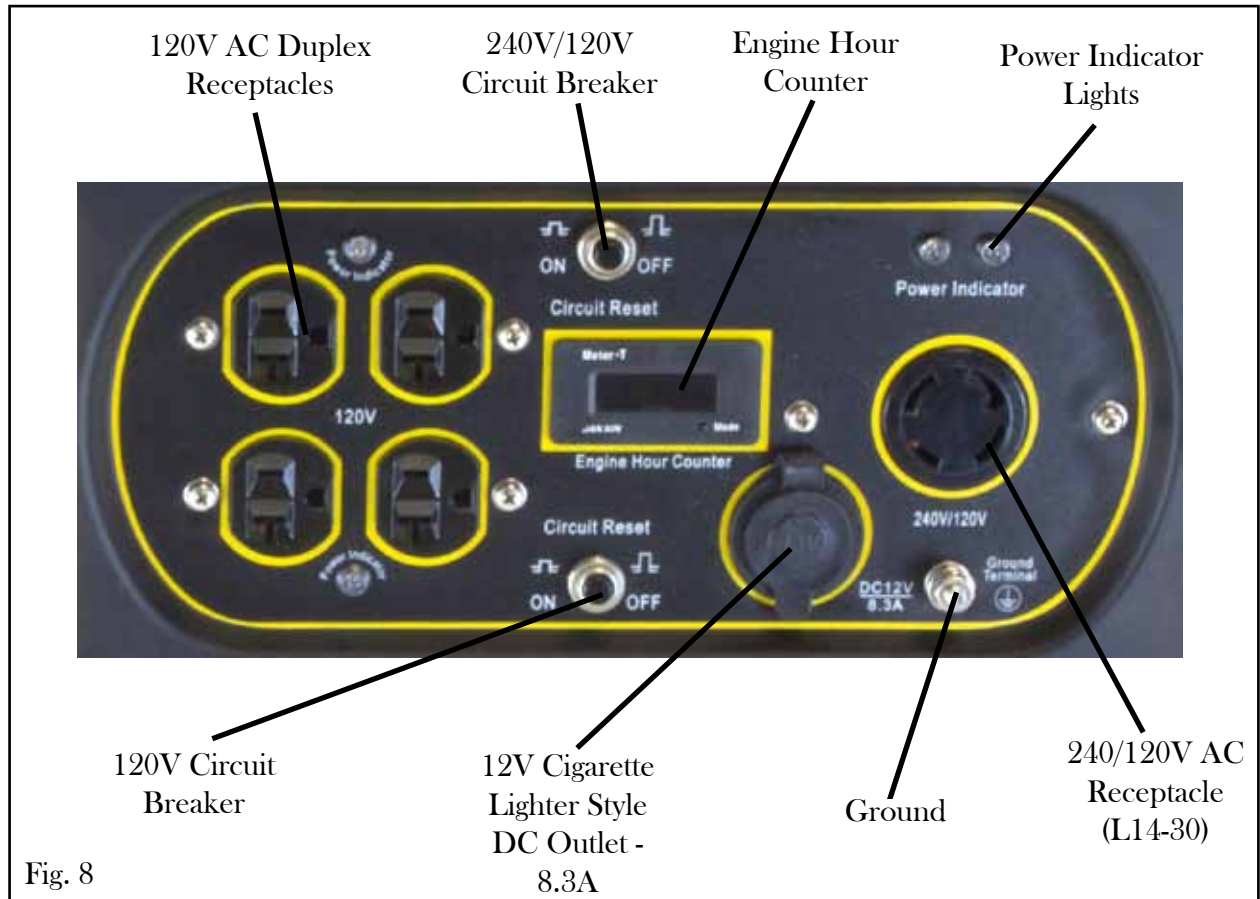

Fig. 8

MAINTENANCE

Proper routine maintenance of the generator will help prolong the life of the machine. Please perform maintenance checks according to the schedule in Fig. 9. If there are any questions about the maintenance procedures listed in this manual, please call (800) 232-1195 M-F 8-5CT.

CAUTION: Never perform maintenance operations while the generator is running.

Recommended Maintenance Schedule		Each 8 hours or daily	First 8 hours	Every 25 hours	Every 3 months or 50 hours	Every 6 months or 100 hours	Every year	As necessary
Engine oil	Check level	x						
	Replace		x	x*	x*			x
Air cleaner cartridge	Check			x		x		
	Clean				x			
Spark plug	Check/clean					x		
	Change						x	x
Fuel tank	Check level	x						
	Clean						x	

Fig. 9

* Clean/change more often under dusty conditions or operating under heavy load.

TO MAXIMIZE THE LIFESPAN OF THIS GENERATOR, MAKE SURE TO RUN IT AT LEAST ONCE A MONTH. IF YOU DO NOT RUN IT OFTEN, IT WILL GREATLY SHORTEN THE LIFESPAN AND PERFORMANCE OF THE GENERATOR.

MAINTENANCE

HIGH ALTITUDE OPERATION ABOVE 3000 FEET

The fuel system on this generator may be affected by operation at high altitudes. Proper operation can be ensured by installing an altitude kit at altitudes higher than 3000 feet above sea level. At elevations above 8000 feet, the engine may experience a decrease in performance, even with the proper altitude kit. Operating this generator without said kit may increase the engine's emissions and decrease both fuel economy and performance.

The kit should be installed by a qualified mechanic. Refer to the instructions included with your altitude kit for more information about installation.



WARNING: To prevent serious injury from fire, follow the kit installation procedures in a well-ventilated area away from ignition sources. If the engine is hot from use, shut the engine off and wait for it to cool before proceeding. Do not smoke near the generator. Warranty will be void if adjustments are not made for high altitude use.

CLEANING THE GENERATOR

Never clean the generator when it is running! Never clean with a bucket of water or a hose. Water can get inside the working parts of the generator and cause corrosion or a short circuit.

Always try to use the generator in a cool, dry place. If the generator becomes dirty, clean the exterior with a damp cloth, a soft brush, a vacuum or pressurized air.

CHECKING THE OIL

Check the oil level of the generator according to the Recommended Maintenance Schedule in Fig. 9. The generator is equipped with an automatic shutoff to protect it from running on low oil. The generator should be checked before each use for proper oil level. This is a critical step for proper engine starting. To check the oil level:

1. Make sure the generator is on a level surface.
2. Open access panel. Clean around oil fill. Remove dipstick and wipe the dipstick with a clean rag. Insert the dipstick into the oil fill opening without screwing in. Remove the dipstick to check the oil mark. Add oil if the oil mark covers less than one half of the dipstick.
3. Slowly add more oil and repeat step 2 until the oil mark reaches to the top of dipstick (Fig. 10). Do not over fill the crankcase.
4. Reinstall oil dipstick and access panel.

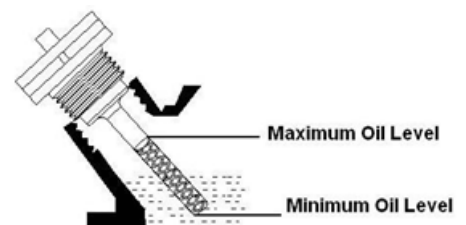

Fig. 10 - Oil Fill Opening, Dipstick and Oil Level

MAINTENANCE

CHANGING/DRAINING THE OIL

Change the oil according to the Recommended Maintenance Schedule in Fig. 9. Changing the oil when the engine is warm allows for complete drainage. Change the oil more often if operating under heavy load or high ambient temperatures. It is also necessary to drain the oil from the crankcase if it has become contaminated with water or dirt. The oil capacity of the generator engine is 1.1 liters (37 fluid ounces). Add oil when the oil level is low. For proper type and weight of oil refer to “add oil” portion of the “Generator Preparation” section. Drain the oil from the generator according to the following steps after removing the side panel.

1. Place a container underneath the engine to catch the oil as it drains.
2. Using a 10 mm hex wrench, unscrew the oil drain plug (Fig. 11). Allow the oil to drain from the engine.
3. Reinstall the oil drain plug and tighten with a 10 mm hex wrench.

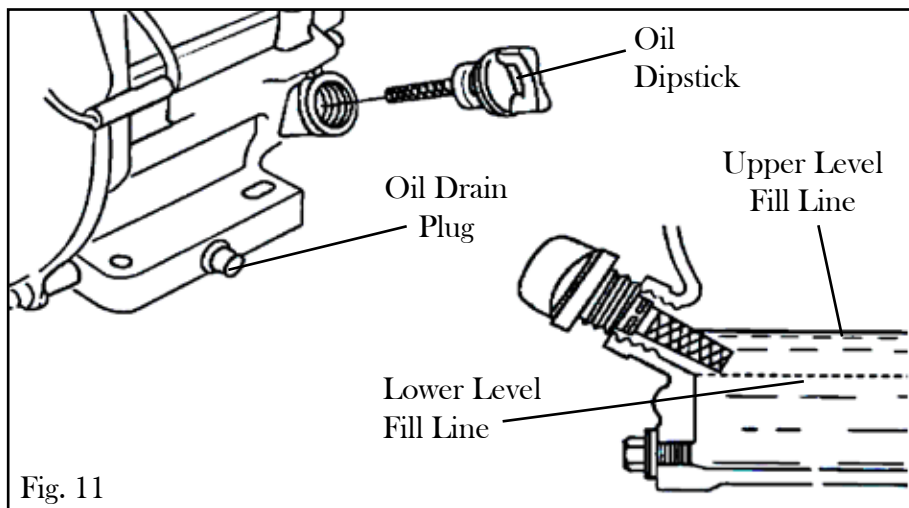

TO REFILL THE OIL

1. Make sure the generator is on a level surface. Tilting the generator to assist in filling will cause oil to flow into engine areas and will cause damage. Keep generator level!
2. Remove the dipstick from the engine.
3. Using a funnel or appropriate dispenser, add the correct amount of oil into the crankcase. The engine is equipped with a low oil pressure sensor and will not start if the amount of oil is insufficient.
4. The oil is full when it reaches halfway up the threads of the dipstick (oil upper level fill line - Fig. 11). Reinstall dipstick.

NOTE: Never dispose of used motor oil in the trash or down a drain. Please call a local recycling center or auto garage to arrange oil disposal.

MAINTENANCE

AIR CLEANER MAINTENANCE

Routine maintenance of the air cleaner helps maintain proper airflow to the carburetor. Occasionally check that the air cleaner is free of excessive dirt. Refer to Recommended Maintenance Schedule in Fig. 9. For air cleaner detail, refer to Fig. 12.

1. Unscrew the cover bolt, then remove the air cleaner cover.
2. Remove the air cleaner element from the casing (the sponge-like filter inside).
3. Check and clean the spongy filter. Replace with a new one if the element has been damaged. Good filters can be washed in soapy water, dried and reused.
4. Wipe off excessive oil from the air cleaner case. Small amounts of oil in the element is normal and necessary for the engine to work properly.
5. Reinstall the air cleaner element and cover.

CAUTION: running the engine with dirty, damaged or missing air cleaner element will cause the engine to wear out prematurely.

FUEL FILTER CUP CLEANING

The fuel filter cup is a small well underneath the fuel valve. It helps to trap dirt and water that may be in the fuel tank before it can enter the engine. To clean the fuel filter cup:

1. Turn the fuel valve to the “OFF” position (Fig. 13).
2. Unscrew the fuel filter cup from the fuel valve using a wrench. Turn the valve towards you and unscrew it.
3. Clean the cup of all sediments using a rag or brush.
4. Reinstall the fuel filter cup.

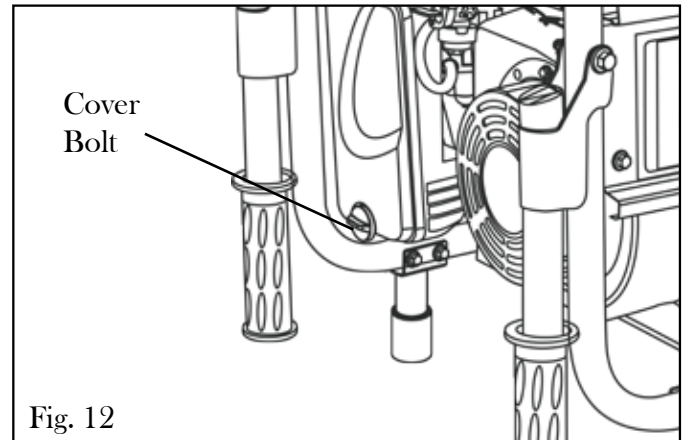

Fig. 12

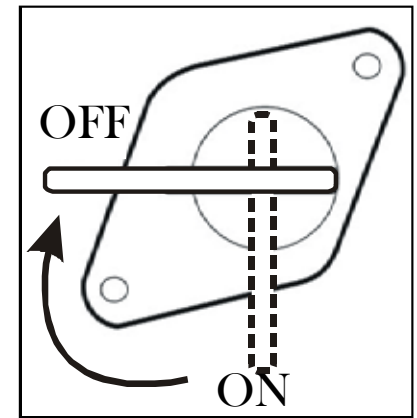

Fig. 13 - Fuel Valve

TO MAXIMIZE THE LIFESPAN OF THIS GENERATOR, MAKE SURE TO RUN IT AT LEAST ONCE A MONTH. IF YOU DO NOT RUN IT OFTEN, IT WILL GREATLY SHORTEN THE LIFESPAN AND PERFORMANCE OF THE GENERATOR.

MAINTENANCE

SPARK PLUG MAINTENANCE

Check the spark plug regularly for proper engine operation (refer to the Recommended Maintenance Schedule in Fig. 9). A good spark plug should be intact, free of deposits, and properly gapped. To inspect the spark plug:

1. Pull on the spark plug cap to remove it. Be careful not to tear insulation or wire.
2. Unscrew the spark plug from the engine using the spark plug wrench provided. There is limited space for the wrench to turn. Use both rows of holes in the spark plug wrench to gain leverage and loosen the plug.
3. Visually inspect the spark plug for cracks or excessive electrode wear. Replace as necessary (F6TC).
4. Measure the plug gap with a spark plug gap gauge. The gap should be 0.7 to 0.8 mm (0.028-0.031 in.) (Fig. 16).
5. If you are re-using the spark plug, use a wire brush to clean any dirt from around the spark plug base then re-gap the spark plug.
6. Screw the spark plug back into the spark plug hole using the spark plug wrench. Do not over-tighten the spark plug. Recommended tightening is $\frac{1}{2}$ to $\frac{3}{4}$ of a turn after the spark plug gasket contacts spark plug hole. Reinstall the spark plug cap.

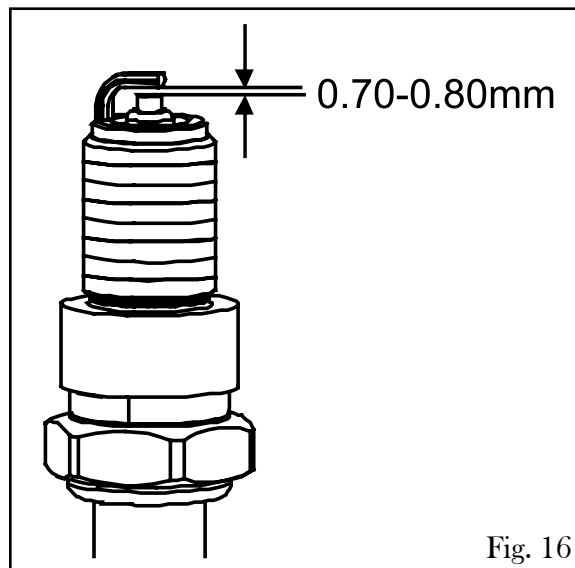
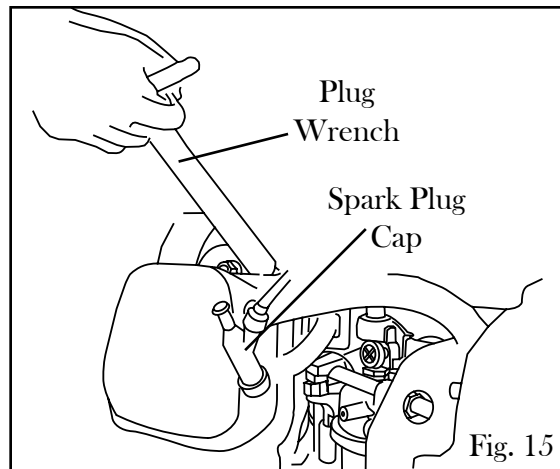
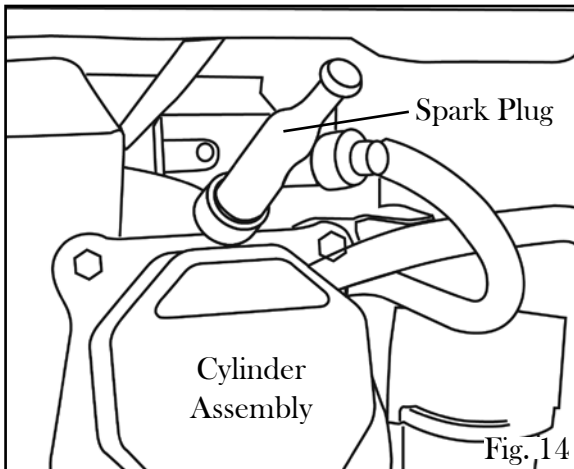

STORAGE & TRANSPORT

DRAINING THE FUEL TANK

Clean the fuel tank each year or before storing the generator for extended periods of time. To drain the fuel tank and carburetor:

1. Turn the fuel valve to the “OFF” position.
2. Remove the fuel line between the fuel valve and carburetor.

CAUTION: A small amount of fuel may leak from the hose during removal.

3. Attach a fuel line (not included with the generator) to the exposed end of the fuel valve.
4. Position the fuel line into an appropriate container and open the fuel valve.
5. Once the fuel is drained, shut off the fuel valve.
6. Start and run the engine until the fuel runs out.
7. Remove the fuel filter cup (see Fuel Filter Cup Cleaning on page 21).
8. Empty the fuel filter cup of any fuel and clean.
9. Reinstall the fuel filter cup.
10. Store the emptied gasoline in a suitable place.

CAUTION: Do not store fuel for more than 3 months.

TO MAXIMIZE THE LIFESPAN OF THIS GENERATOR, MAKE SURE TO RUN IT AT LEAST ONCE A MONTH. IF YOU DO NOT RUN IT OFTEN, IT WILL GREATLY SHORTEN THE LIFESPAN AND PERFORMANCE OF THE GENERATOR.

STORAGE & TRANSPORT

CAUTION: Never place any type of storage cover on the generator while it is still hot.

If the generator is being stored for short periods of time (30 to 60 days), add stabilized fuel to the fuel tank until full. **NOTE:** Filling the tank reduces the amount of air in the tank and helps reduce deterioration of fuel. Run the engine for 2 - 3 minutes allowing stabilized fuel mixture to circulate through the carburetor.

When storing the generator for extended periods of time:

- Drain the fuel tank (see Draining the Fuel Tank on page 23).
- Change oil.
- Do not obstruct any ventilation openings.
- Keep the generator in a cool dry area.

When transporting generator:

- Tighten fuel cap and vacuum relief valve. Drain the fuel tank if possible (see Draining the Fuel Tank on page 23).
- Keep the generator upright. Never place the generator side down. Doing so will make it difficult to start.

SPECIFICATIONS

Rated Wattage	5000 Watts
Surge Wattage	5500 Watts
Rated Voltage	240V/120V
Rated Amperage	20.5A (240V) / 41A (120V)
Frequency	60 Hz
Phase	Single
Dimensions	Length: 27.6 inches
	Width: 21.1 inches
	Height: 22.1 inches
Weight	187 lbs

Engine

Engine Type	4-stroke OHV single cylinder with forced air cooling system
Spark Plug Gap	0.7 - 0.8 mm (0.028 - 0.031 in)
Spark Plug Torque	1/2 - 3/4 turn after gasket contacts base or 15 ft. lb
Displacement	389 cc
Fuel Tank Capacity	6.5 gallons (25 L)
Oil Capacity	37 fl. oz (1.1 L)
Run Time on 50% Load	11 hours
Noise Rating	67 dB idle 74 dB fully loaded
Spark Plug	F6TC

TROUBLESHOOTING

IMPORTANT: If trouble persists, please call our customer help line at (800) 232-1195 M-F 8-5 Central Time.

PROBLEM	CAUSE	SOLUTION
Engine will not start.	Engine switch is set to "OFF."	Set engine switch to "ON."
	Fuel valve is turned to "OFF."	Turn the fuel valve to the "ON" position.
	Choke is open.	Close the choke.
	Engine is out of fuel.	Add gasoline.
	Engine is filled with contaminated or old gasoline.	Change the gasoline in the gas tank.
	Spark plug is dirty.	Clean spark plug.
	Spark plug is broken.	Replace spark plug.
	Generator is not on a level surface.	Move generator to a level surface to prevent low oil shutdown from triggering.
	Oil is low.	Add or replace oil.
Engine runs but there is no electrical output.	Circuit reset button is off.	Wait for 2 minutes and push the circuit reset button to the "ON" position.
	Bad connecting wires/cables.	If you are using an extension cord, try a different one.
	Bad electrical device connected to the generator.	Try connecting a different device.
Generator runs but does not support all electrical devices connected.	Generator is over-loaded.	Perform these steps: 1) Turn off all electrical devices 2) Unplug all electrical devices 3) Turn off generator 4) Wait several minutes 5) Restart generator 6) Try connecting fewer electrical loads to the generator.
	Short in one of the connected devices.	Try disconnecting any faulty or short-circuited electrical loads.
	Air cleaner is dirty.	Clean or replace air cleaner.

EXPLODED VIEW AND PARTS LIST

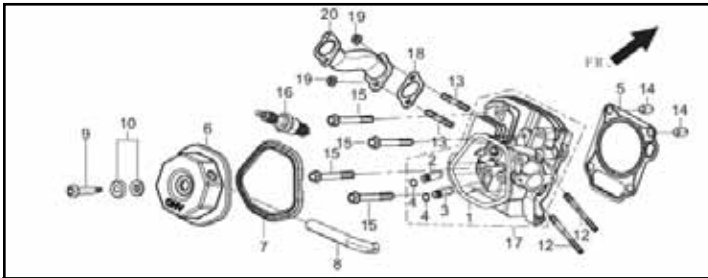

Fig. 1 - Cylinder Head Assembly

No.	Part	Description	Qty.
Fig 1-5	56682-E-001	Cylinder Head Gasket	1
Fig 1-6	56682-E-002	Cylinder Head Cover Subassembly	1
Fig 1-7	56682-E-003	Cylinder Head Cover Gasket	1
Fig 1-8	56682-E-004	Breather Tube	1
Fig 1-9	56682-E-005	Cylinder Bolt	1
Fig 1-10	56682-E-005	Cylinder Washer	1
Fig 1-12	56682-E-006	Stud	2
Fig 1-13	56682-E-007	Stud	2
Fig 1-14	56682-E-008	Pin	2
Fig 1-15	56682-E-009	Cylinder Head Bolt	4
Fig 1-16	56682-E-010	Spark Plug	1
Fig 1-17	56551-E-011	Cylinder Head Assembly	1
Fig 1-18	56877-E-012	Exhaust Gasket	1
Fig 1-19	56682-E-013	Nut	2
Fig 1-20	56551-E-014	Exhaust Gasket	1

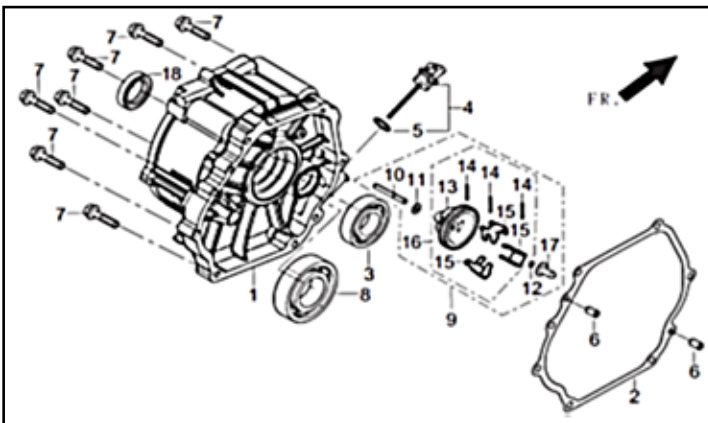

Fig. 3 - Crankcase Cover Assembly

No.	Part	Description	Qty.
Fig 3-1	56682-E-030	Crankcase Cover	1
Fig 3-2	56551-E-031	Crankcase Gasket	1
Fig 3-3	56682-E-032	Bearing	1
Fig 3-4	56551-E-033	Oil Dipstick Assembly	1
Fig 3-6	56682-E-034	Pin	2
Fig 3-7	56682-E-035	Bolt M8x32	7
Fig 3-8	56877-E-036	Bearing	1
Fig 3-9	56682-E-037	Governor Gear Assembly	1
Fig 3-18	56682-E-038	Oil Seal	1

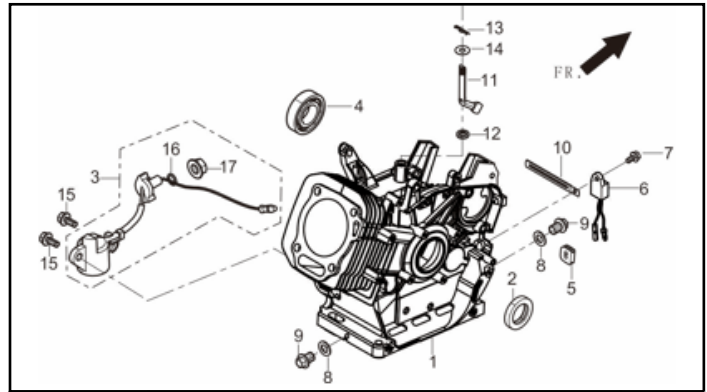

Fig. 2 - Crankcase Assembly

No.	Part	Description	Qty.
Fig 2-1	56551-E-015	Crankcase Subassembly	1
Fig 2-2	56682-E-016	Oil Seal	1
Fig 2-3	56682-E-017	Oil Sensor	1
Fig 2-4	56682-E-018	Bearing	1
Fig 2-5	56682-E-019	Oil Plug	1
Fig 2-6	56682-E-020	Oil Protector	1
Fig 2-7	56682-E-021	Bolt	1
Fig 2-8	56682-E-022	Washer	2
Fig 2-9	56682-E-023	Drain Plug	2
Fig 2-10	56682-E-024	Clip	1
Fig 2-11	56682-E-025	Governor Arm	1
Fig 2-12	56682-E-026	Rubber Washer	1
Fig 2-13	56682-E-027	Pin	1
Fig 2-14	56682-E-028	Washer	1
Fig 2-15	56682-E-029	Bolt	2
Fig 2-16	56682-E-029A	Washer	
Fig 2-17	56877-E-030	Nut	1

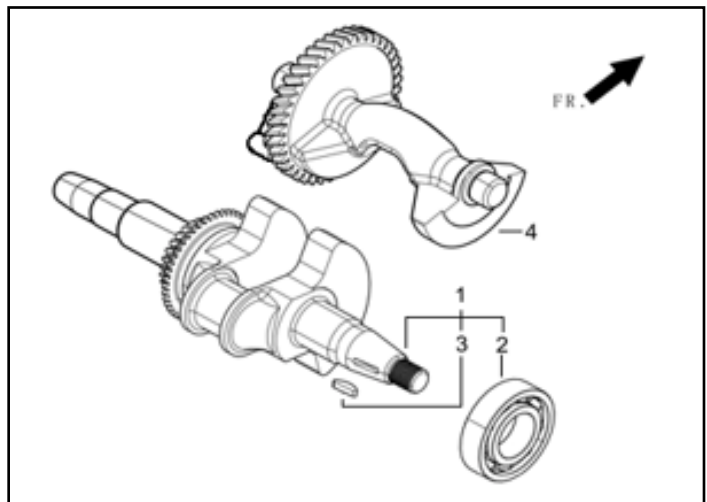

Fig. 4 - Crankshaft

No.	Part	Description	Qty.
Fig 4-1	56682-E-039	Crankshaft Assembly	1
Fig 4-4	56682-E-040	Balancer	1

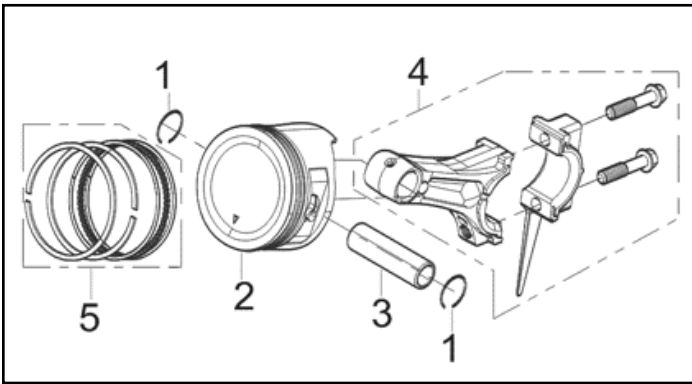

Fig. 5 - Piston Ring/Connecting Rod

No.	Part	Description	Qty.
Fig. 5-1	56682-E-042	Piston Pin Clip	2
Fig. 5-2	56682-E-043	Piston	1
Fig. 5-3	56682-E-044	Piston Pin	1
Fig. 5-4	56682-E-045	Connecting Rod Assembly	1
Fig. 5-5	56682-E-046	Piston Ring Set	1

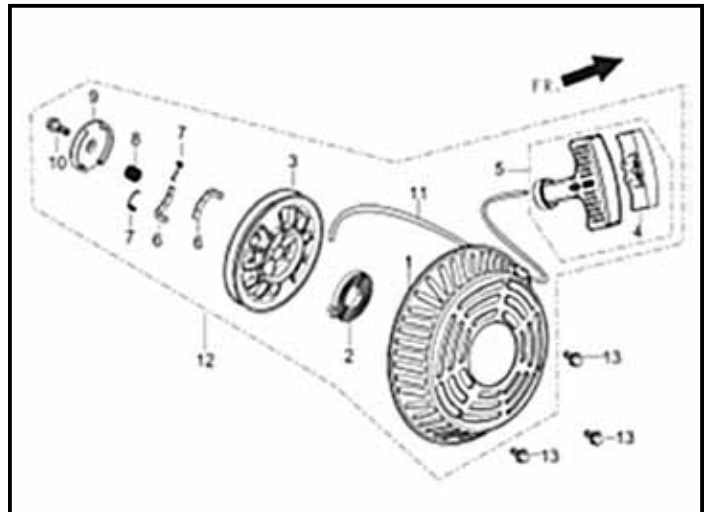

Fig. 7 - Recoil Starter

No.	Part	Description	Qty.
Fig. 7-12	56682-E-64	Recoil Starter Assembly	1
Fig. 7-13	56682-E-65	Bolt	3

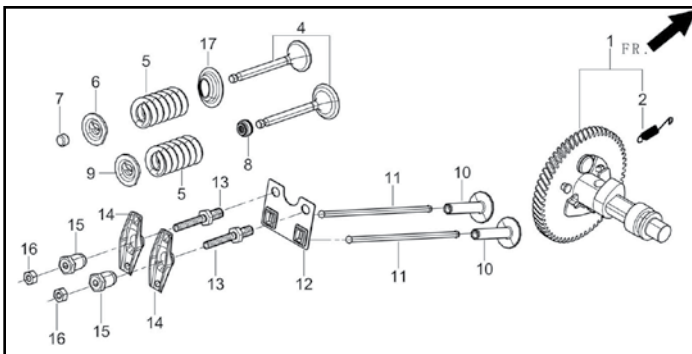

Fig. 6 - Valve/Camshaft Assembly

No.	Part	Description	Qty.
Fig. 6-1	56682-E-048	Camshaft Assembly	1
Fig. 6-4	56682-E-049	Valve	2
Fig. 6-5	56682-E-062	Valve Spring	2
Fig. 6-6	56682-E-052	Valve Spring Seat	1
Fig. 6-7	56682-E-053	Valve Lock	1
Fig. 6-8	56682-E-054	Guide Seal	1
Fig. 6-9	56682-E-051	Valve Spring Seat	1
Fig. 6-10	56682-E-055	Tappet	2
Fig. 6-11	56682-E-056	Lifter	2
Fig. 6-12	56682-E-057	Push Guide Plate	1
Fig. 6-13	56682-E-058	Valve Adjusting Bolt	2
Fig. 6-14	56682-E-059	Valve Rocker	2
Fig. 6-15	56682-E-060	Sleeve	2
Fig. 6-16	56682-E-061	Lock Nut	2
Fig. 6-17	56682-E-063	Valve Spring Retainer	1

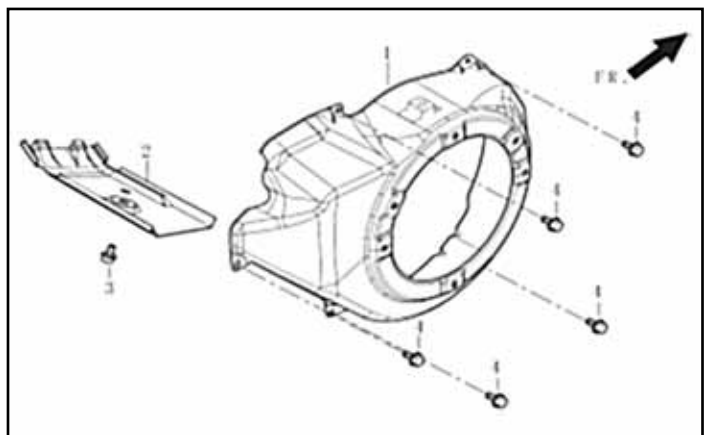

Fig. 8 - Shroud

No.	Part	Description	Qty.
Fig. 8-1	56682-E-066	Shroud Body	1
Fig. 8-2	56682-E-067	Shroud Body Cover	1
Fig. 8-3	56682-E-068	Bolt	1
Fig. 8-4	56682-E-069	Bolt	5

EXPLODED VIEW AND PARTS LIST

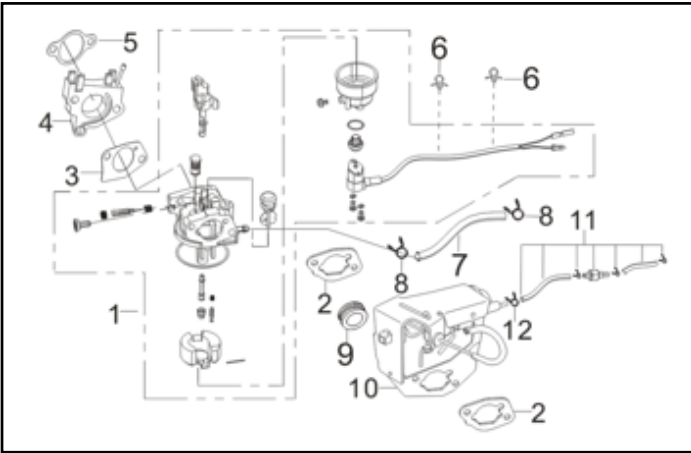

Fig. 9 - Carburetor Assembly

No.	Part	Description	Qty.
Fig. 9-1	56682-E-070	Carburetor Assembly	1
Fig. 9-2	56682-E-071	Air Cleaner Gasket	2
Fig. 9-3	56682-E-072	Carburetor Gasket	1
Fig. 9-4	56682-E-073	Carburetor Insulator Plate	1
Fig. 9-5	56682-E-074	Gasket Inlet	1
Fig. 9-6	56682-E-075	Clip	2
Fig. 9-7	56682-E-076	Fuel Tube	1
Fig. 9-8	56682-E-077	Collar	2
Fig. 9-9	56682-E-078	Breather Tube	1
Fig. 9-10	56682-E-079	Choke Control Assembly	1
Fig. 9-11	56682-E-080	One Way Valve	1

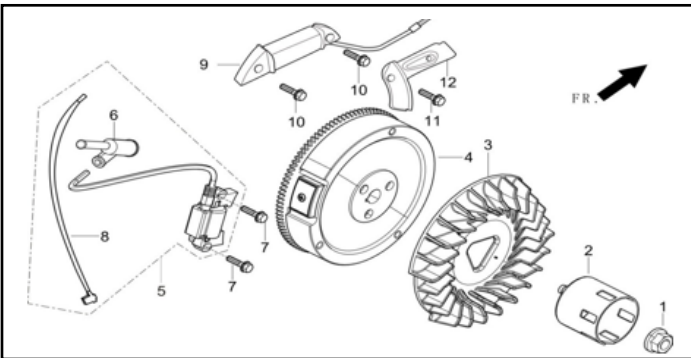

Fig. 11 - Flywheel/Ignition Coil

No.	Part	Description	Qty.
Fig. 11-1	56682-E-083	Flywheel Nut	1
Fig. 11-2	56682-E-084	Starting Flange	1
Fig. 11-3	56682-E-085	Flywheel Fan	1
Fig. 11-4	56551-E-086	Flywheel Subassembly	1
Fig. 11-5	56682-E-088	Ignition Coil Assembly	1
Fig. 11-7	56682-E-087	Bolt	2
Fig. 11-9	56682-E-092	Charge Coil Subassembly	1
Fig. 11-10	56682-E-091	Bolt	2
Fig. 11-11	56682-E-089	Bolt	1
Fig. 11-12	56682-E-090	Coil Clamp	1

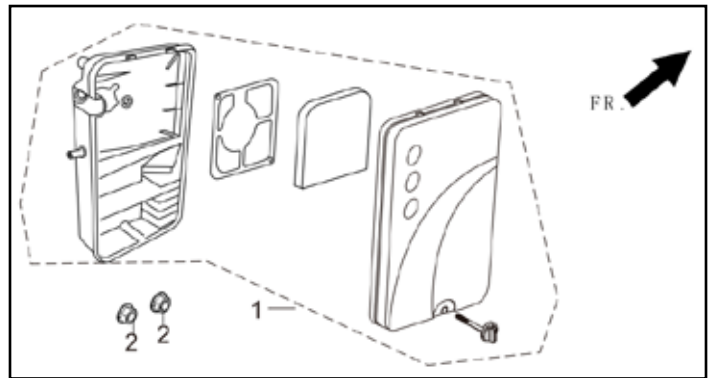

Fig. 10 - Air Cleaner

No.	Part	Description	Qty.
Fig. 10-1	56682-E-081	Air Cleaner Assembly	1
Fig. 10-2	56682-E-082	Nut	1

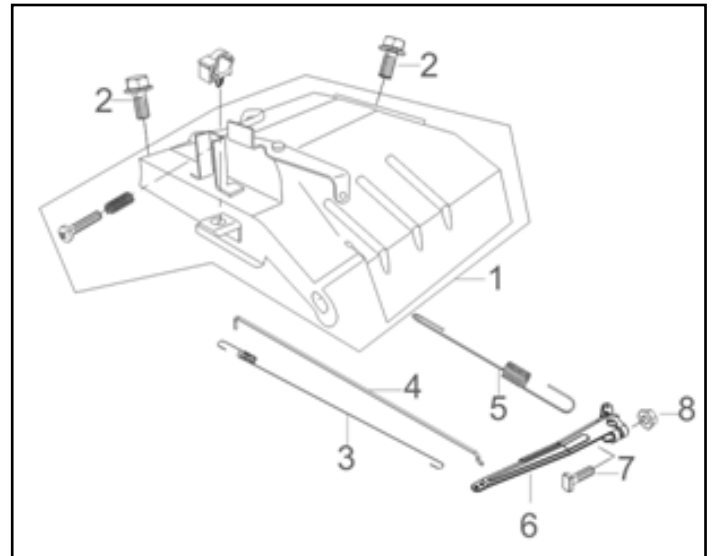

Fig. 12 - Control Assembly

No.	Part	Description	Qty.
Fig. 12-1	56682-E-094	Regulating Arm	1
Fig. 12-2	56682-E-093	Nut M6	2
Fig. 12-3	56682-E-095	Back Spring	1
Fig. 12-4	56682-E-096	Pulling Rod	1
Fig. 12-5	56551-E-097	Regulating Spring	1
Fig. 12-6	56682-E-098	Regulating Arm	1
Fig. 12-7	56682-E-100	Bolt	1
Fig. 12-8	56682-E-099	Nut	2

EXPLODED VIEW AND PARTS LIST

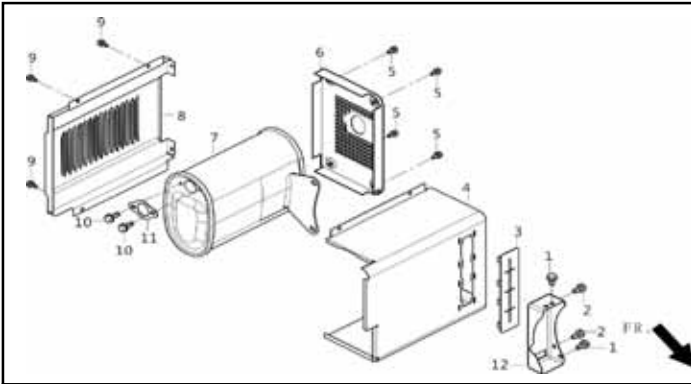

Fig. 13 - Muffler Assembly

No.	Part	Description	Qty.
Fig. 13-1	56877-G-001	Bolt	2
Fig. 13-2	56877-G-002	Bolt	2
Fig. 13-3	56877-G-003	Rubber Cushion	1
Fig. 13-4	56551-G-004	Muffler Inner Cover	1
Fig. 13-5	56877-G-005	Bolt	4
Fig. 13-6	56877-G-006	Muffler Side Cover	1
Fig. 13-7	56551-G-007	Muffler Assembly	1
Fig. 13-8	56877-G-008	Muffler Outer Cover	1
Fig. 13-9	56877-G-009	Bolt	3
Fig. 13-10	56877-G-010	Bolt	2
Fig. 13-11	56877-G-011	Exhaust Gasket	1
Fig. 13-12	56877-G-012	Muffler Bracket	1

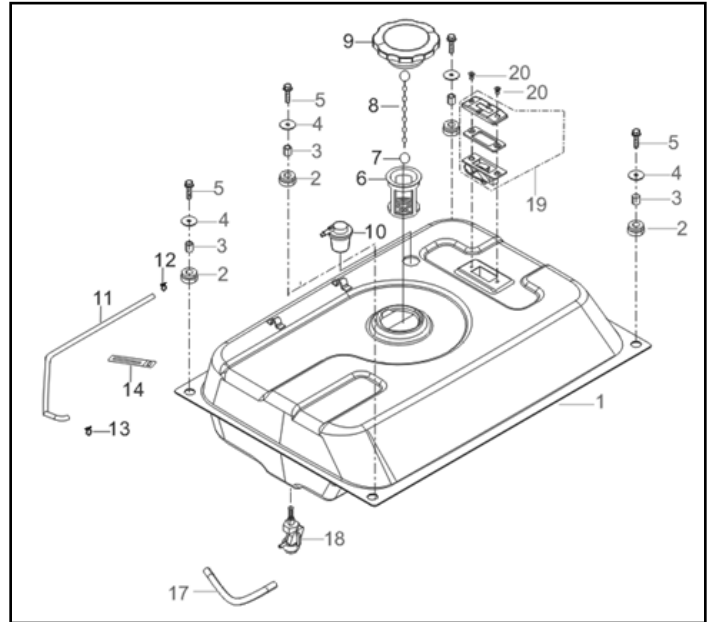

Fig. 14 - Tank, Fuel

No.	Part	Description	Qty.
F14-1	56551-G-013	Fuel Tank	1
F14-2	56877-G-016	Cushion	4
F14-3	56877-G-017	Bushing	4
F14-4	56877-G-018	Washer	4
F14-5	56877-G-019	Bolt	4
F14-6	56877-G-014	Fuel Filter	1
F14-7	56877-G-094	Clip	1
F14-8	56877-G-093	Chain	1
F14-9	56877-G-015	Fuel Cap	1
F14-10	56877-G-095	One Way Valve	1
F14-11	56551-G-097	Pressure Relief Hose	1
F14-12	56877-G-096	Clamp	1
F14-13	56877-G-098	Clamp	1
F14-14	56877-G-101	Bracket	1
F14-17	56877-G-023	Rubber Sleeve	1
F14-18	56877-G-022	Fuel Cock	1
F14-19	56877-G-020	Fuel Gauge Assembly	1
F14-20	56877-G-021	Screw	2

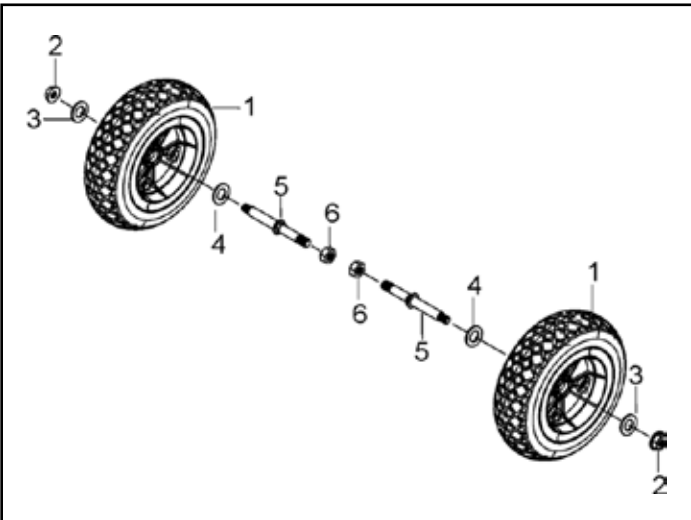

Fig. 15 - Wheel Assembly

No.	Part	Description	Qty.
Fig. 15-1	56551-G-089	Front Wheel	2
Fig. 15-2	56551-G-087	Nut	2
Fig. 15-3	56551-G-088	Washer	2
Fig. 15-4	56551-G-090	Washer	2
Fig. 15-5	56551-G-091	Front Wheel Shaft	2
Fig. 15-6	56877-G-092	Nut	2

EXPLODED VIEW AND PARTS LIST

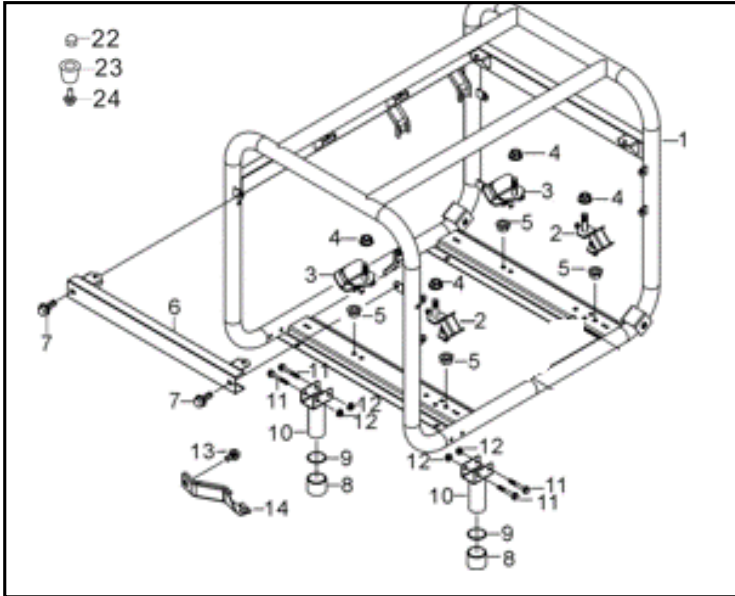
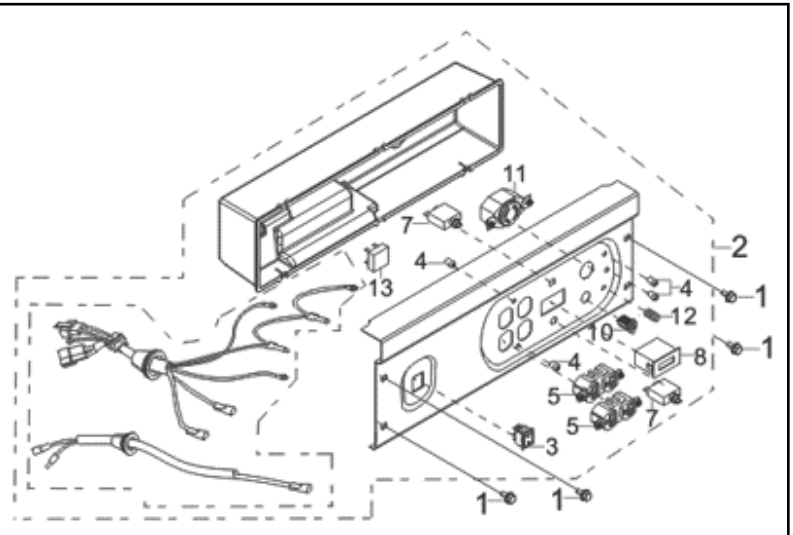

Fig. 16 - Panel Subassembly, Control

No.	Part	Description	Qty.
Fig 16-1	56551-G-024	Frame	1
Fig 16-2	56877-G-033	Front Cushion	2
Fig 16-3	56877-G-035	Back Cushion	2
Fig 16-4	56877-G-034	Nut	4
Fig 16-5	56877-G-032	Nut	4
Fig 16-6	56877-G-044	Crosspiece Subassembly	1
Fig 16-7	56877-G-043	Bolt	2
Fig 16-8	56877-G-036	Rubber Foot	2
Fig 16-9	56877-G-037	Washer	2
Fig 16-10	56551-G-038	Front Foot Base	2
Fig 16-11	56877-G-039	Bolt	4
Fig 16-12	56877-G-040	Nut	4
Fig 16-13	56877-G-042	Bolt	1
Fig 16-14	56877-G-041	Air Cleaner Bracket	1
Fig 16-22	56551-G-622	Nut	4
Fig 16-23	56551-G-623	Rubber Cushion	4
Fig 16-24	56551-G-624	Bolt	4

Fig. 17 - Panel

No.	Part	Description	Qty.
Fig. 17-1	56877-G-046	Bolt	4
Fig. 17-2	56551-G-051	Control Panel Subassembly	1
Fig. 17-3	56551-G-048	Switch Subassembly	1
Fig. 17-4	56877-G-047	Indicator Light	4
Fig. 17-5	56877-G-048	Socket Subassembly	2
Fig. 17-6	56877-G-049	20A Circuit Breaker	2
Fig. 17-7	56551-G-049	30A Circuit Breaker	2
Fig. 17-8	56551-G-056	Timer	1
Fig. 17-9	56877-G-055	120 30Amp Socket	1
Fig. 17-10	56877-G-054	12 V Socket	1
Fig. 17-11	56551-G-053	120/240 30Amp Socket	1
Fig. 17-12	56551-G-050	Grounding Terminal	1
Fig. 17-13	56877-G-052	Rectifier	1



EXPLODED VIEW AND PARTS LIST

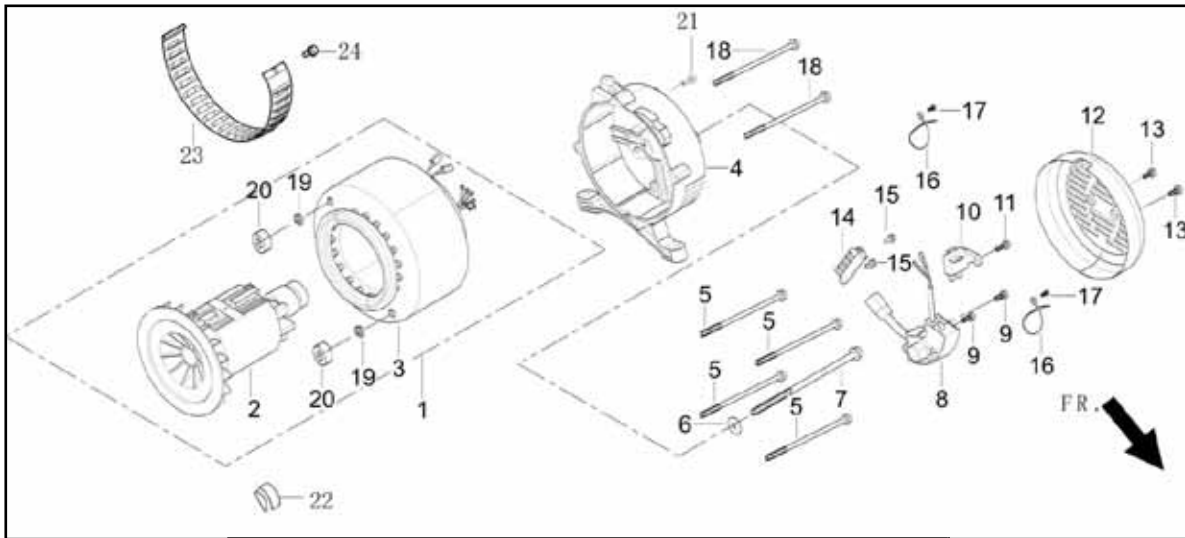
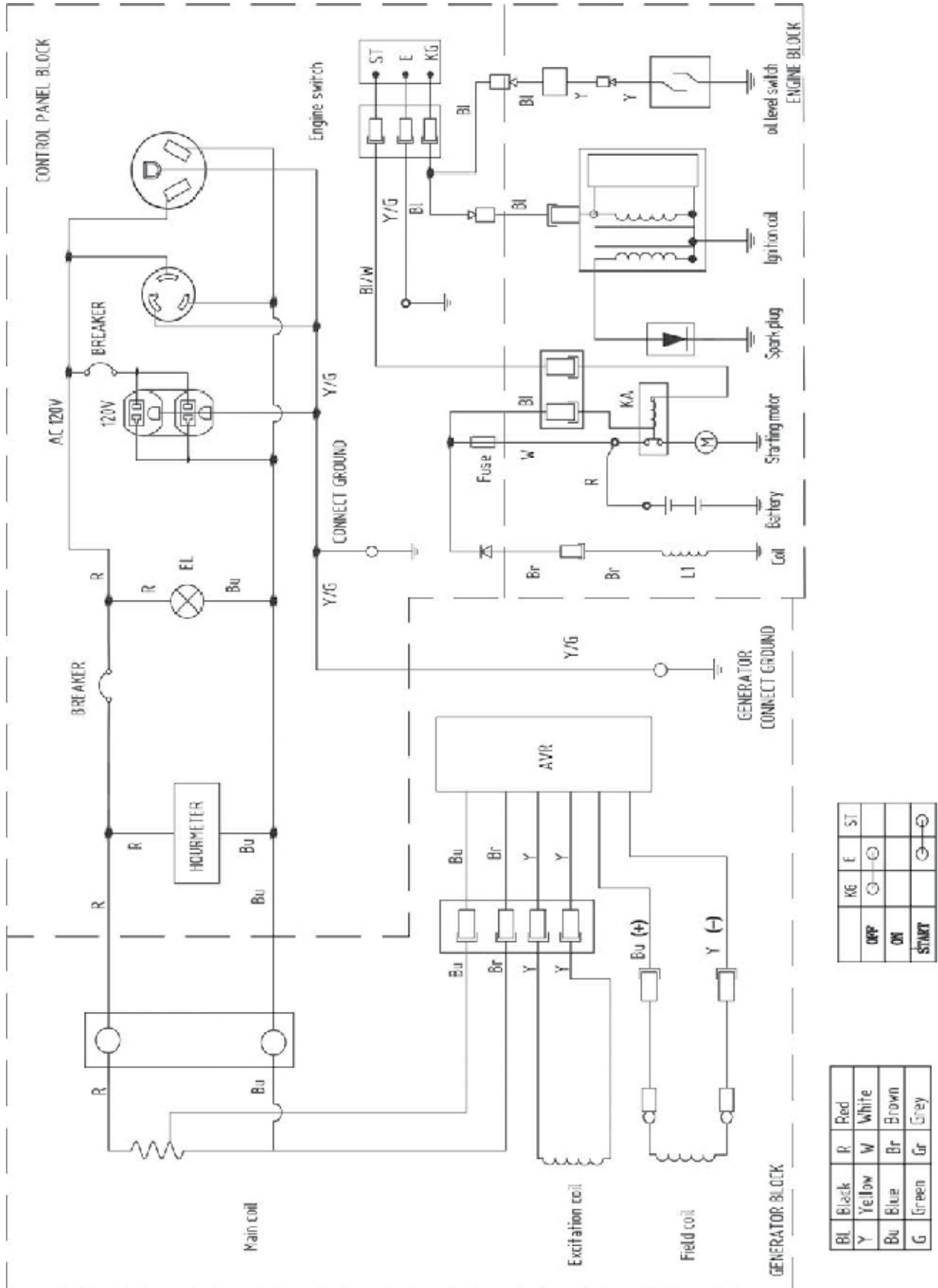

Fig. 18 - Rotor/Stator

No.	Part	Description	Qty.
Fig. 18-1	56877-G-079	Rotor Assembly	1
Fig. 18-4	56877-G-067	Rotor Bracket	1
Fig. 18-5	56682-G-072	Stator Bolt	4
Fig. 18-6	56877-G-070	Washer	1
Fig. 18-7	56682-G-071	Rotor Bolt	1
Fig. 18-8	56551-G-072	Voltage Regulator	1
Fig. 18-9	56877-G-074	Bolt	2
Fig. 18-10	56877-G-064	Carbon Brush Assembly	1
Fig. 18-11	56877-G-065	Bolt	1
Fig. 18-12	56551-G-077	Cover	1
Fig. 18-13	56877-G-078	Bolt	2
Fig. 18-14	56877-G-063	Terminal	1
Fig. 18-15	56877-G-066	Bolt	2
Fig. 18-16	56877-G-075	Wire Tie	2
Fig. 18-17	56877-G-066	Bolt	2
Fig. 18-18	56682-G-068	Stator Bolt	2
Fig. 18-19	56877-G-061	Washer	2
Fig. 18-20	56877-G-060	Stator Nut	2
Fig. 18-21	56877-G-068	Bolt	1
Fig. 18-23	56877-G-080	Motor Shroud	1
Fig. 18-24	56877-G-081	Bolt	1

WIRING DIAGRAM



WARRANTY STATEMENT

Remember to save the receipt and to accurately fill out and mail the product registration card. Proof of purchase is required for all warranty work.

WEN® Generators are under warranty to be free from defects in materials and workmanship for a period of two (2) years from date of original purchase. Generators used for Commercial or Rental use have a warranty period of 90 days from date of original purchase. Keep purchase receipt and mail in the product registration card for proof of purchase.

WEN® will repair or replace, at its discretion, any part that is proven to be defective in materials or workmanship under normal use during the two (2) years warranty period. Warranty repairs or replacements will be made without charge for parts or labor. Parts replaced during warranty repairs will be considered as part of the original product and will have the same warranty period as the original product.

To exercise the warranty, **DO NOT RETURN TO RETAILER**. Instead, call the toll free Customer Service number at (800) 232-1195 and you will be instructed on where to take the generator for warranty service. Take the generator and proof of purchase (the receipt) to the repair facility recommended by the Customer Service Representative. To make a claim under this Limited Warranty, you must make sure to keep a copy of your proof of purchase that clearly defines the Date of Purchase (month and year) and the Place of Purchase. Place of purchase must be a direct vendor of Great Lakes Technologies, LLC. Third party vendors such as garage sales, pawn shops, resale shops, or any other secondhand merchant void the warranty included with this product. Contact techsupport@wenproducts.com or 1-800-232-1195 to make arrangements for repairs and transportation.

When returning a product for warranty service, the shipping charges must be prepaid by the purchaser. The product must be shipped in its original container (or an equivalent), properly packed to withstand the hazards of shipment. The product must be fully insured with a copy of the warranty card and/or the proof of purchase enclosed. There must also be a description of the problem in order to help our repairs department diagnose and fix the issue. Repairs will be made and the product will be returned and shipped back to the purchaser at no charge.

THIS LIMITED WARRANTY DOES NOT APPLY TO ACCESSORY ITEMS THAT WEAR OUT FROM REGULAR USAGE OVER TIME INCLUDING BELTS, BRUSHES, BLADES, ETC.

The warranty does not extend to generators damaged or affected by fuel contamination, accidents, neglect, misuse, unauthorized alterations, use in an application for which the product was not designed and any other modifications or abuse.

WEN® is not liable for any indirect, incidental or consequential damages from the sale or use of this product. Any implied warranties are limited to two (2) years as stated in this written limited warranty. Some states do not allow the exclusion or limitation of incidental or consequential damages. Some states do not allow limitation on the length of an implied warranty. This warranty gives you specific legal rights, and you may have other rights that vary from state to state.

THANKS FOR REMEMBERING

