

INSTRUCTION MANUAL

EXPLODED VIEW & PARTS LIST

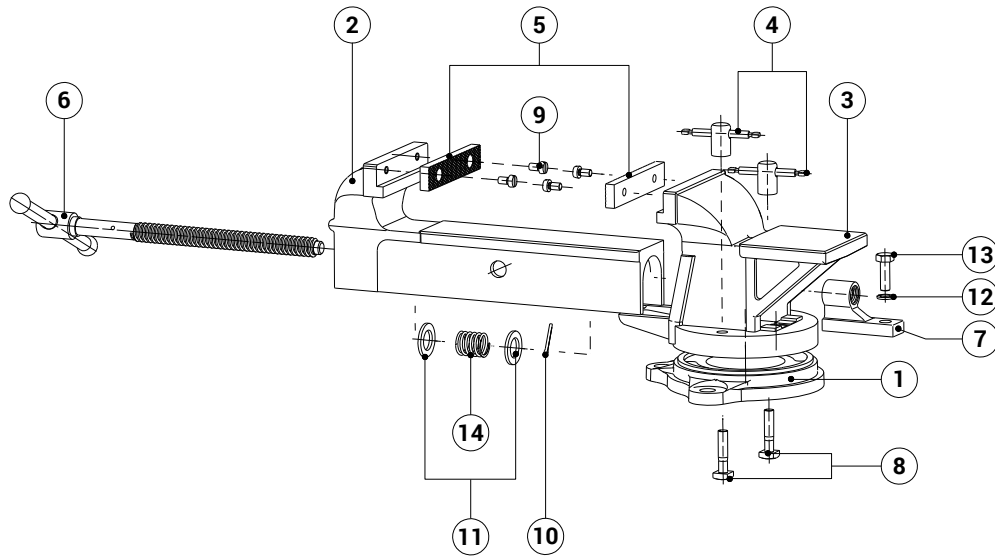

MODEL 454BV

4-INCH BENCH VISE

ÉTAU DE BANC

KNOW YOUR BENCH VISE

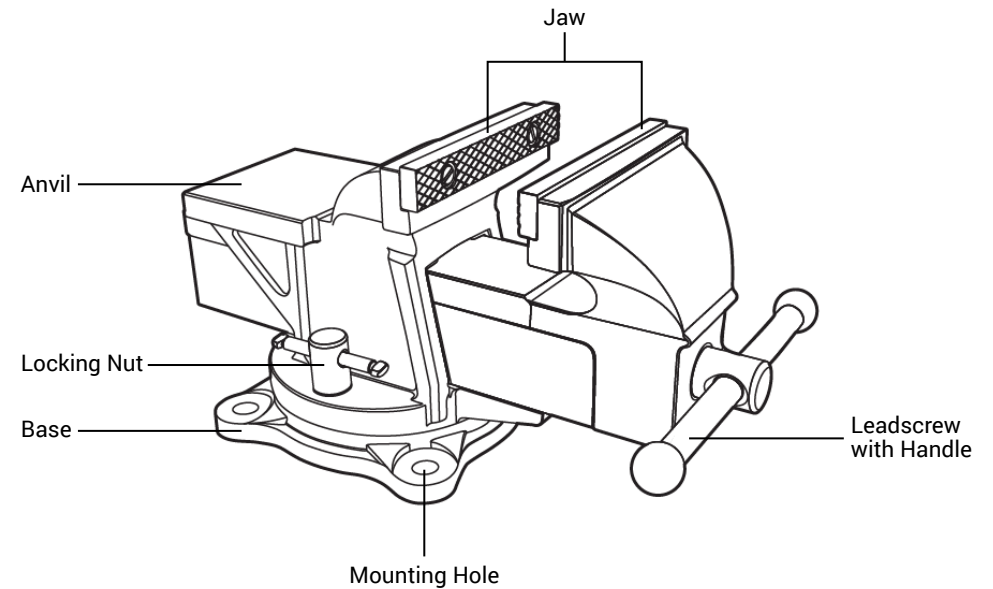

SPECIFICATIONS

Jaw Width	4 in.
Jaw Capacity	5-1/8 in.
Anvil Dimensions	85 x 80 mm
Mounting Hole Diameter	12 mm
Mounting Hole Spacing	107 mm
Clamping Force	2443 lbf (11 kN)
Pivoting Angle Range	130.0°
Dimensions	12-1/4 in. x 5-1/2 in. x 6-1/8 in.
Weight	17.2 lb

No.	Part No.	Description	Qty.
1	454BV-001	Base	1
2	454BV-002	Movable Jaw	1
3	454BV-003	Body	1
4	453BV-004	Locking Nut	2
5	454BV-005	Jaw Plate	2
6	454BV-006	Leadscrew With Handle	1
7	453BV-007	Nut	1
8	454BV-008	Square Head Bolt, M8x35	2
9	454BV-009	Set Screw, M6x10	4
10	453BV-010	Split Pin, Ø2.5x25	1
11	453BV-011	Locking Washer, M16	2
12	453BV-012	Split Washer, M8	1
13	454BV-013	Hex Bolt, M8x25	1
14	453BV-014	Spring	1

INSTRUCTION MANUAL

MOUNTING INSTRUCTIONS

Follow the instructions below to safely and securely mount your bench vise to a stable workbench. Mounting your vise eliminates the risk of your vise moving or falling, allowing for more accuracy and user safety.

1. Select a secure worktop to which your vise will be mounted, such as a workbench. The workbench should be sturdy and fixed to the floor.
2. Find the best location on your worktop to mount your vise. It is good to select a spot that allows access to the leadscrew with handle, as well as the pivot locking nuts. Recommended mounting placements can be seen in Fig. 1. When choosing a location, make sure the leadscrew is on your dominant-hand side for rotating purposes.
3. Once you have selected where you want to mount your vise, use a pencil to mark the holes where the vise will be bolted (three mounting flanges are located on the base). You must use at least two bolts that are opposite of each other to securely mount the vice; use three bolts for optimum stability.
4. Move the vise to the side and use a drill to drill out the marked spots for the bolts.
5. Line up the vise with the drilled holes. Insert bolts and fasten. If the bolts extend through the bench, place a washer and nut onto the end (Fig. 2). Tighten nuts onto the bolts using a wrench. (Fasteners are not included.)

NOTE: To prevent the bolt from loosening over time, use split locking washers between flat washers and nuts, or use nylon locking nuts.

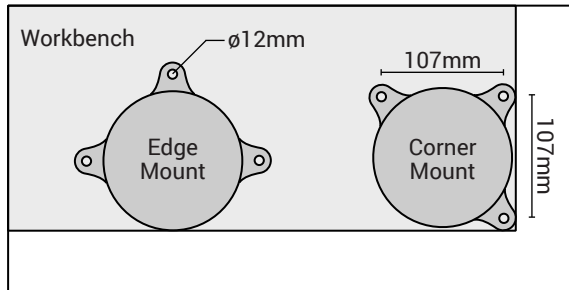

Fig. 1

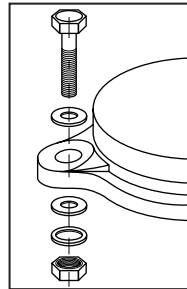

Fig. 2

MAINTENANCE

⚠ Acetone may irritate the skin. Wear gloves and eye protection when using acetone.

- Your vise comes with a layer of anti-rust protective coating on the machined surfaces. Remove this coating with a clean cloth moistened with acetone, then protect the machined surfaces by applying a light coat of good-quality paste wax.
- After using your vise, wipe it off with a cloth to ensure that no chips, shavings, or other debris get into the way of your vise. Keep your vise clean. Periodically check the ways of the vise to ensure that they are not blocked or damaged by chips, shavings, or other debris.
- To keep leadscrew and other moving parts lubricated, use multipurpose grease.
- To prevent the surface from rusting, occasionally apply mineral oil to the surfaces.
- Only tighten jaws by hand, otherwise you may damage the vise or your workpiece.

OPERATION

Before operation, mount your vise, using the "Mounting Instructions" section.

1. Mark your workpiece for your specific job.
2. Rotate the leadscrew with handle counterclockwise to open the jaws. Place workpiece inside of jaws in desired position. Rotate the handle clockwise to tighten the jaws and firmly secure your workpiece. See Fig. 3.
3. Complete your specific job. Rotate the leadscrew counterclockwise to release your workpiece.

HOW TO PIVOT YOUR VISE

1. Turn both locking nuts counterclockwise to loosen them (Fig. 4). (Loosening the locking nuts too much will cause them to detach from the bolts underneath. To reattach the nut to the bolt, turn the locking nut clockwise onto the bolt.)
2. Pivot the vise body to the desired angle (Fig. 4).
3. Turn both locking nuts clockwise until they are tightened (Fig. 4). Your vise is now secured in your desired position, and you may continue working on your project.

NOTE: To prevent accidents, locking nuts must be tightened before working on your workpiece.

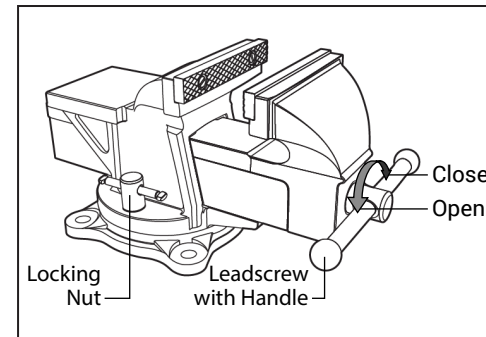

Fig. 3

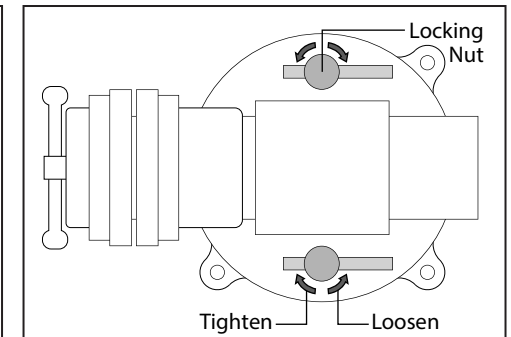

Fig. 4

ANVIL USES

The anvil on the back of your bench vise can be utilized as a forging tool for metal work. It is not recommended to hit anvil with excessive force, as this may damage the vise.

NEED HELP? CONTACT US!

Have product questions? Need technical support?
Please feel free to contact us at:

800-232-1195 (M-F 8-5 CST)

techsupport@wenproducts.com

WENPRODUCTS.COM