

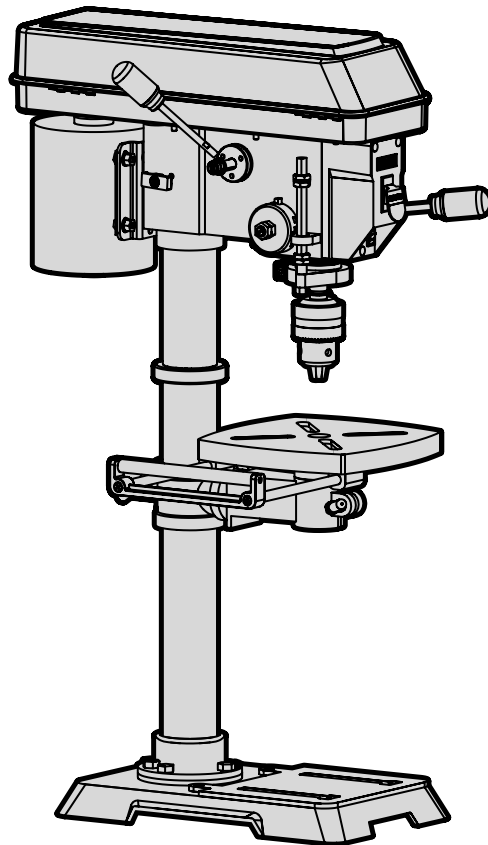

MODEL 4214, 4214T

12" VARIABLE SPEED DRILL PRESS

Instruction Manual



NEED HELP? CONTACT US!

Have product questions? Need technical support? Please feel free to contact us:



1-847-429-9263 (M-F 8AM-5PM CST)



TECHSUPPORT@WENPRODUCTS.COM

IMPORTANT: Your new tool has been engineered and manufactured to WEN's highest standards for dependability, ease of operation, and operator safety. When properly cared for, this product will supply you years of rugged, trouble-free performance. Pay close attention to the rules for safe operation, warnings, and cautions. If you use your tool properly and for its intended purpose, you will enjoy years of safe, reliable service.

For replacement parts and the most up-to-date instruction manuals, visit ***WENPRODUCTS.COM***

CONTENTS

WELCOME	3
Introduction	3
Specifications.....	3
SAFETY	4
General Safety Rules	4
Specific Safety Rules for the Drill Press.....	6
Electrical Information	8
Know Your Drill Press	9
BEFORE OPERATING	10
Assembly & Adjustments.....	10
OPERATION & MAINTENANCE	19
Operation	19
Maintenance.....	23
Troubleshooting Guide	24
Exploded View & Parts List.....	26
Warranty Statement	29

To purchase accessories and replacement parts for your tool, visit **WENPRODUCTS.COM**

INTRODUCTION

Thanks for purchasing the WEN Drill Press. We know you are excited to put your tool to work, but first, please take a moment to read through the manual. Safe operation of this tool requires that you read and understand this operator's manual and all the labels affixed to the tool. This manual provides information regarding potential safety concerns, as well as helpful assembly and operating instructions for your tool.

 Indicates danger, warning, or caution. The safety symbols and the explanations with them deserve your careful attention and understanding. Always follow the safety precautions to reduce the risk of fire, electric shock or personal injury. However, please note that these instructions and warnings are not substitutes for proper accident prevention measures.

NOTE: The following safety information is not meant to cover all possible conditions and situations that may occur. WEN reserves the right to change this product and specifications at any time without prior notice.

At WEN, we are continuously improving our products. If you find that your tool does not exactly match this manual, please visit wenproducts.com for the most up-to-date manual or contact our customer service at **1-847-429-9263**.

Keep this manual available to all users during the entire life of the tool and review it frequently to maximize safety for both yourself and others.

SPECIFICATIONS

Model Number	4214, 4214T
Motor	120V, 60 Hz, 5A
Speed	580-3100 RPM (no load)
Chuck Capacity	1/8" - 5/8"
Stroke	3-1/8"
Swing	12"
Capacity (Chuck to Base)	20"
Chuck Taper	JT3
Spindle Taper	MT2
Table Bevel	0 to 45° left and right
Laser	Class III, transformer powered, 650 nm, <2.5 mW
Product Weight	85 lbs
Product Dimensions	22 in. x 14-1/2 in. x 37 in.

GENERAL SAFETY RULES

 **WARNING!** Read all safety warnings and all instructions. Failure to follow the warnings and instructions may result in electric shock, fire and/or serious injury.

Safety is a combination of common sense, staying alert and knowing how your item works. The term “power tool” in the warnings refers to your mains-operated (corded) power tool or battery-operated (cordless) power tool.

SAVE THESE SAFETY INSTRUCTIONS.

WORK AREA SAFETY

- 1. Keep work area clean and well lit.** Cluttered or dark areas invite accidents.
- 2. Do not operate power tools in explosive atmospheres, such as in the presence of flammable liquids, gases or dust.** Power tools create sparks which may ignite the dust or fumes.
- 3. Keep children and bystanders away while operating a power tool.** Distractions can cause you to lose control.

ELECTRICAL SAFETY

- 1. Power tool plugs must match the outlet. Never modify the plug in any way. Do not use any adapter plugs with earthed (grounded) power tools.** Unmodified plugs and matching outlets will reduce risk of electric shock.
- 2. Avoid body contact with earthed or grounded surfaces such as pipes, radiators, ranges and refrigerators.** There is an increased risk of electric shock if your body is earthed or grounded.
- 3. Do not expose power tools to rain or wet conditions.** Water entering a power tool will increase the risk of electric shock.
- 4. Do not abuse the cord. Never use the cord for carrying, pulling or unplugging the power tool. Keep cord away from heat, oil, sharp edges or moving parts.** Damaged or entangled cords increase the risk of electric shock.
- 5. When operating a power tool outdoors, use an extension cord suitable for outdoor use.** Use of a cord suitable for outdoor use reduces the risk of electric shock.
- 6. If operating a power tool in a damp location is un-**

avoidable, use a ground fault circuit interrupter (GFCI) protected supply. Use of a GFCI reduces the risk of electric shock.

PERSONAL SAFETY

- 1. Stay alert, watch what you are doing and use common sense when operating a power tool. Do not use a power tool while you are tired or under the influence of drugs, alcohol or medication.** A moment of inattention while operating power tools may result in serious personal injury.
- 2. Use personal protective equipment. Always wear eye protection.** Protective equipment such as a respiratory mask, non-skid safety shoes and hearing protection used for appropriate conditions will reduce the risk of personal injury.
- 3. Prevent unintentional starting. Ensure the switch is in the off-position before connecting to power source and/or battery pack, picking up or carrying the tool.** Carrying power tools with your finger on the switch or energizing power tools that have the switch on invites accidents.
- 4. Remove any adjusting key or wrench before turning the power tool on.** A wrench or a key left attached to a rotating part of the power tool may result in personal injury.
- 5. Do not overreach. Keep proper footing and balance at all times.** This enables better control of the power tool in unexpected situations.
- 6. Dress properly. Do not wear loose clothing or jewelry. Keep your hair and clothing away from moving parts.** Loose clothes, jewelry or long hair can be caught in moving parts.

GENERAL SAFETY RULES

⚠ WARNING! Read all safety warnings and all instructions. Failure to follow the warnings and instructions may result in electric shock, fire and/or serious injury.

Safety is a combination of common sense, staying alert and knowing how your item works. The term “power tool” in the warnings refers to your mains-operated (corded) power tool or battery-operated (cordless) power tool.

SAVE THESE SAFETY INSTRUCTIONS.

7. If devices are provided for the connection of dust extraction and collection facilities, ensure these are connected and properly used. Use of dust collection can reduce dust-related hazards.

POWER TOOL USE AND CARE

1. Do not force the power tool. Use the correct power tool for your application. The correct power tool will do the job better and safer at the rate for which it was designed.

2. Do not use the power tool if the switch does not turn it on and off. Any power tool that cannot be controlled with the switch is dangerous and must be repaired.

3. Disconnect the plug from the power source and/or the battery pack from the power tool before making any adjustments, changing accessories, or storing power tools. Such preventive safety measures reduce the risk of starting the power tool accidentally.

4. Store idle power tools out of the reach of children and do not allow persons unfamiliar with the power tool or these instructions to operate the power tool. Power tools are dangerous in the hands of untrained users.

5. Maintain power tools. Check for misalignment or binding of moving parts, breakage of parts and any other condition that may affect the power tool’s operation. If damaged, have the power tool repaired before use. Many accidents are caused by poorly maintained power tools.

6. Keep cutting tools sharp and clean. Properly maintained cutting tools with sharp cutting edges are less likely to bind and are easier to control.

7. Use the power tool, accessories and tool bits, etc. in accordance with these instructions, taking into account the working conditions and the work to be performed. Use of the power tool for operations different from those intended could result in a hazardous situation.

8. Use clamps to secure your workpiece to a stable surface. Holding a workpiece by hand or using your body to support it may lead to loss of control.

9. KEEP GUARDS IN PLACE and in working order.

SERVICE

1. Have your power tool serviced by a qualified repair person using only identical replacement parts. This will ensure that the safety of the power tool is maintained.

CALIFORNIA PROPOSITION 65 WARNING

Some dust created by power sanding, sawing, grinding, drilling, and other construction activities may contain chemicals, including lead, known to the State of California to cause cancer, birth defects, or other reproductive harm. Wash hands after handling. Some examples of these chemicals are:

- Lead from lead-based paints.
- Crystalline silica from bricks, cement, and other masonry products.
- Arsenic and chromium from chemically treated lumber.

Your risk from these exposures varies depending on how often you do this type of work. To reduce your exposure to these chemicals, work in a well-ventilated area with approved safety equipment such as dust masks specially designed to filter out microscopic particles.

DRILL PRESS SAFETY WARNINGS

 **WARNING!** Do not let comfort or familiarity with the product replace strict adherence to product safety rules. Failure to follow the safety instructions may result in serious personal injury.

1. **TOOL PURPOSE.** This drill press is designed to drill through metal wood, plastic, and tiles. Drilling through other materials could result in fire, injury, or damage to the workpiece. Using the machine for any other purpose for which it is not designed may result in serious injuries, machine damage and voiding of the warranty.
2. **MACHINE MOUNTING.** For operation safety, the drill press must be securely mounted onto a flat and stable surface or stand.
3. **PERSONAL SAFETY.**
 - Always wear ANSI Z87.1-approved glasses with side shields, hearing protection and a dust mask.
 - Do not wear loose clothing or jewelry, as they might get drawn in by the tool. Tie back long hair.
 - DO NOT wear gloves while operating this machine.
4. **Electric Cords.** Keep cords away from heat, oil, sharp edges, and moving parts of the tool. Have an electrician replace or repair damaged or worn cords immediately.
5. **TOOL & ACCESSORIES INSPECTION.** Before operation, check the tool and accessories for any damage or missing parts. Do not use the tool if any part is missing or damaged. Make sure all adjustments are correct and all connections are tight. Keep all guards in place.
6. **DRILLING ACCESSORIES.**
 - Make sure the drill bit is not damaged before use; only use undamaged drill bits
 - Make sure the drill bit is securely locked in the chuck before turning ON.
 - Make sure the chuck key is removed from the chuck before turning ON.
 - Use clamps or a vise (sold separately to secure a workpiece to the table. This will prevent the workpiece from rotating with the drill bit.
7. Make sure the table lock is tightened before starting the drill press.
8. **WORKPIECE REQUIREMENTS.**
 - Only stand workpieces sturdy enough to withstand the force of the drill bit.
 - Inspect the workpiece for imperfections, nails, staples, etc. before drilling. Never drill stock that has questionable imperfections or embedded foreign objects.
 - Do not drill materials without a flat surface unless a suitable support is used (clamp or vise).
9. **PREVENTING ACCIDENTAL STARTING.** Make sure the power switch is in the OFF position prior to plugging in the machine. Always make sure the power switch is in the OFF position and the machine is unplugged when doing any cleaning, assembly, setup operations, or when not in use.
10. Do not operate this tool until it is completely assembled and installed according to the instructions.
11. Remove scrap pieces and other objects from the table before turning ON the drill press.

DRILL PRESS SAFETY WARNINGS

 **WARNING!** Do not let comfort or familiarity with the product replace strict adherence to product safety rules. Failure to follow the safety instructions may result in serious personal injury.

12. DRILLING THE WORKPIECE.

- Allow spindle to reach full speed before drilling the workpiece.
- Never start the machine with the drill bit pressed against the workpiece.
- Adjust the table or depth stop to avoid drilling into the table.
- Set the drill press to the speed that is appropriate for the material being drilled.

13. Do not touch moving pieces. Keep hands away from the drill bit during operation. If cleaning is necessary, turn off the machine and use a brush to remove sawdust and chips instead of your hands.

14. Never perform layout, assembly or set-up work on the table while the machine is ON.

15. After turning off the drill press, wait until the spindle comes to a complete stop before touching the workpiece. Always turn the drill OFF before removing scrap from the table.

16. Before leaving the machine, always turn OFF and unplug the machine, remove the drill bit, and clean the table. Turn Off and unplug the machine before cleaning, making adjustments or changing drill bits. Accidental start-ups may occur if the tool is plugged in during an accessory change or adjustment.

17. CLEANING. Never use solvents to clean plastic parts. Solvents could dissolve or otherwise damage the material. Use only a soft damp cloth to clean plastic parts.

18. REPLACEMENTS. Should any component of your drill press be missing/damaged or fail in any way, shut OFF the switch and remove the plug from power supply outlet. Replace the missing, damaged, or failed parts using only identical replacement parts before resuming operation.

CALIFORNIA PROPOSITION 65 WARNING

Some dust created by power sanding, sawing, grinding, drilling, and other construction activities may contain chemicals, including lead, known to the State of California to cause cancer, birth defects, or other reproductive harm. Wash hands after handling. Some examples of these chemicals are:

- Lead from lead-based paints.
- Crystalline silica from bricks, cement, and other masonry products.
- Arsenic and chromium from chemically treated lumber.

Your risk from these exposures varies depending on how often you do this type of work. To reduce your exposure to these chemicals, work in a well-ventilated area with approved safety equipment such as dust masks specially designed to filter out microscopic particles.

These safety instructions can't possibly warn of every scenario that may arise with this tool, so always make sure to stay alert and use common sense during operation.

ELECTRICAL INFORMATION

GROUNDING INSTRUCTIONS

In the event of a malfunction or breakdown, grounding provides the path of least resistance for an electric current and reduces the risk of electric shock. This tool is equipped with an electric cord that has an equipment grounding conductor and a grounding plug. The plug **MUST** be plugged into a matching outlet that is properly installed and grounded in accordance with ALL local codes and ordinances.

1. Do not modify the plug provided. If it will not fit the outlet, have the proper outlet installed by a licensed electrician.

2. Improper connection of the equipment grounding conductor can result in electric shock. The conductor with the green insulation (with or without yellow stripes) is the equipment grounding conductor. If repair or replacement of the electric cord or plug is necessary, **DO NOT** connect the equipment grounding conductor to a live terminal.

3. Check with a licensed electrician or service personnel if you do not completely understand the grounding instructions or whether the tool is properly grounded.

4. Use only three-wire extension cords that have three-pronged plugs and outlets that accept the tool's plug (INSERT CR). Repair or replace a damaged or worn cord immediately.

CAUTION! In all cases, make certain the outlet in question is properly grounded. If you are not sure, have a licensed electrician check the outlet.

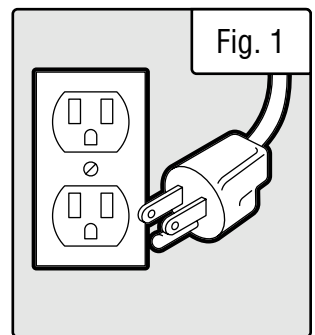

GUIDELINES AND RECOMMENDATIONS FOR EXTENSION CORDS

When using an extension cord, be sure to use one heavy enough to carry the current your product will draw. An undersized cord will cause a drop in line voltage resulting in loss of power and overheating. The table below shows the correct size to be used according to cord length and ampere rating. When in doubt, use a heavier cord. The smaller the gauge number, the heavier the cord.

AMPERAGE	REQUIRED GAUGE FOR EXTENSION CORDS			
	25 ft.	50 ft.	100 ft.	150 ft.
5A	18 gauge	16 gauge	16 gauge	14 gauge

1. Examine extension cord before use. Make sure your extension cord is properly wired and in good condition. Always replace a damaged extension cord or have it repaired by a qualified person before using it.

2. Do not abuse extension cord. Do not pull on cord to disconnect from receptacle; always disconnect by pulling on plug. Disconnect the extension cord from the receptacle before disconnecting the product from the extension cord. Protect your extension cords from sharp objects, excessive heat and damp/wet areas.

3. Use a separate electrical circuit for your tool. This circuit must not be less than a 12-gauge wire and should be protected with a 15A time-delayed fuse. Before connecting the motor to the power line, make sure the switch is in the OFF position and the electric current is rated the same as the current stamped on the motor nameplate. Running at a lower voltage will damage the motor.

KNOW YOUR DRILL PRESS

TOOL PURPOSE

Drill presses are mainly used to drill clean, precise cylindrical holes into workpieces or enlarge existing holes. You may also find other uses for your drill press such as reaming, countersinking, counterboring, tapping, etc. Refer to the diagram below and on page 10 to become familiarized with the parts and controls of your drill press.

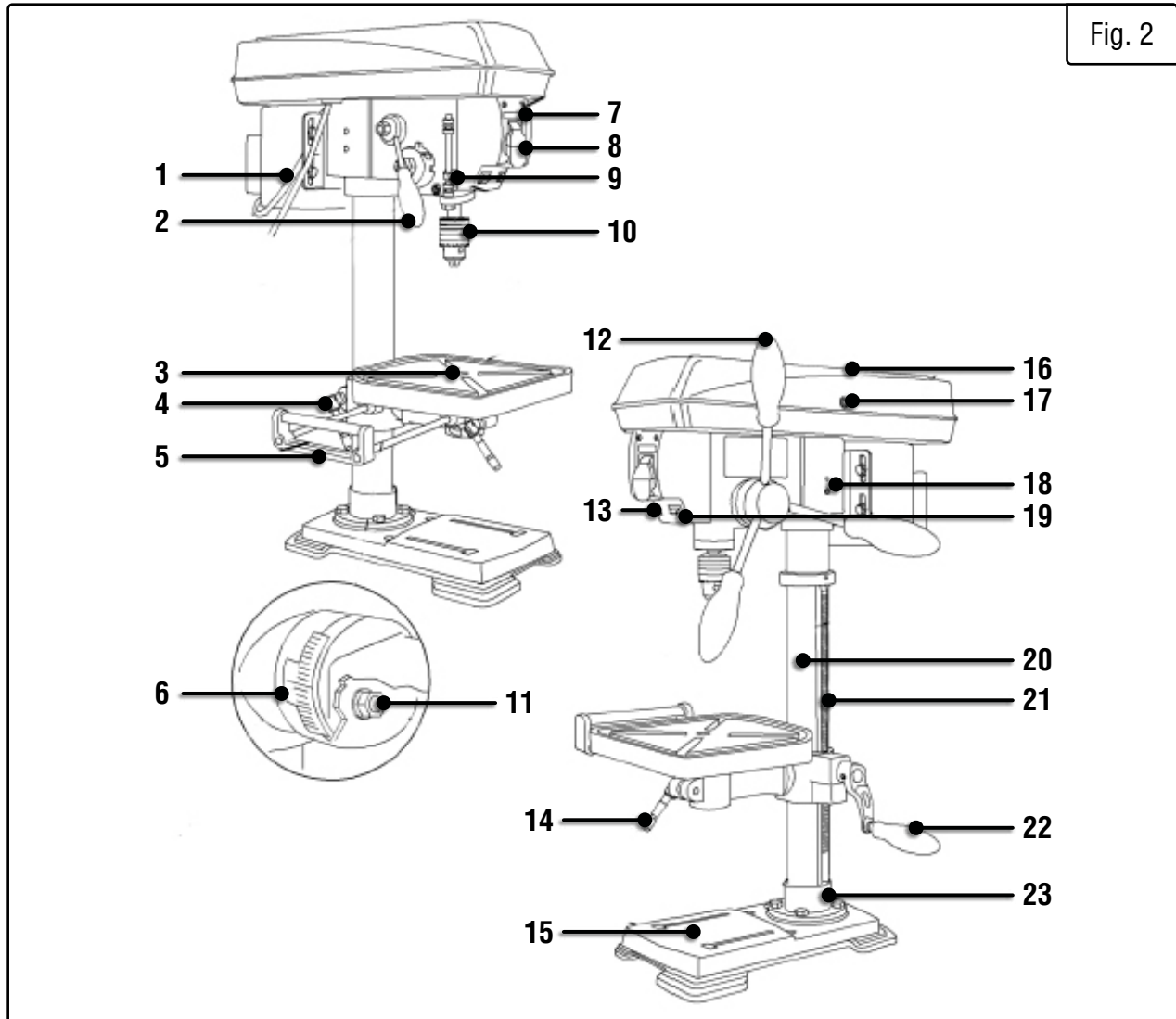

- | | | |
|--|--------------------------|---------------------------|
| 1. Power Cord | 9. Depth Scale | 17. Housing Cover Screw |
| 2. Speed Control Handle | 10. Chuck | 18. Chuck Key Storage |
| 3. Table Top | 11. Bevel Lock Bolt | 19. Laser ON / OFF Switch |
| 4. Support Lock Handle | 12. Feed Handles | 20. Column |
| 5. Extension Wing with Integrated Roller | 13. LED Worklight Switch | 21. Rack |
| 6. Bevel Scale | 14. Table Lock Handle | 22. Crank Handle |
| 7. Digital Speed Readout | 15. Base | 23. Column Support |
| 8. ON / OFF Switch | 16. Housing Cover | |

Various drill bits, vises, clamps and other accessories can be purchased from wenproducts.com

ASSEMBLY & ADJUSTMENTS

UNPACKING

With the help of a friend or trustworthy foe, carefully remove the drill press from the packaging. Make sure to take out all contents and accessories. Do not discard the packaging until the drill press is completely assembled.

Before using the drill press, you must assemble the unit using the instructions in this section. Check your packing list against the diagram below. If any part is damaged or missing, please contact our customer service at **1-847-429-9263**, M-F 8-5 CST or email us at techsupport@wenproducts.com.

CLEANING THE WORK TABLE SURFACE

Your drill press comes protected with a layer of anti-rust coating on its exposed (non-painted) metal surfaces. Clean the rust-protected surfaces using a soft cloth, moistened with kerosene. Do not use gasoline, or cellulose-based solvents such as paint thinner or lacquer thinner, as these will damage the painted surfaces. After cleaning, apply a light coat of good-quality paste wax to the table and column to prevent rust. Wipe all parts thoroughly with a clean, dry cloth.

PACKING LIST

Check your packing list against the diagram below. If any part is damaged or missing, please contact our customer service at **1-847-429-9263**, M-F 8-5 CST or email us at techsupport@wenproducts.com and DO NOT plug the drill press in or turn ON.

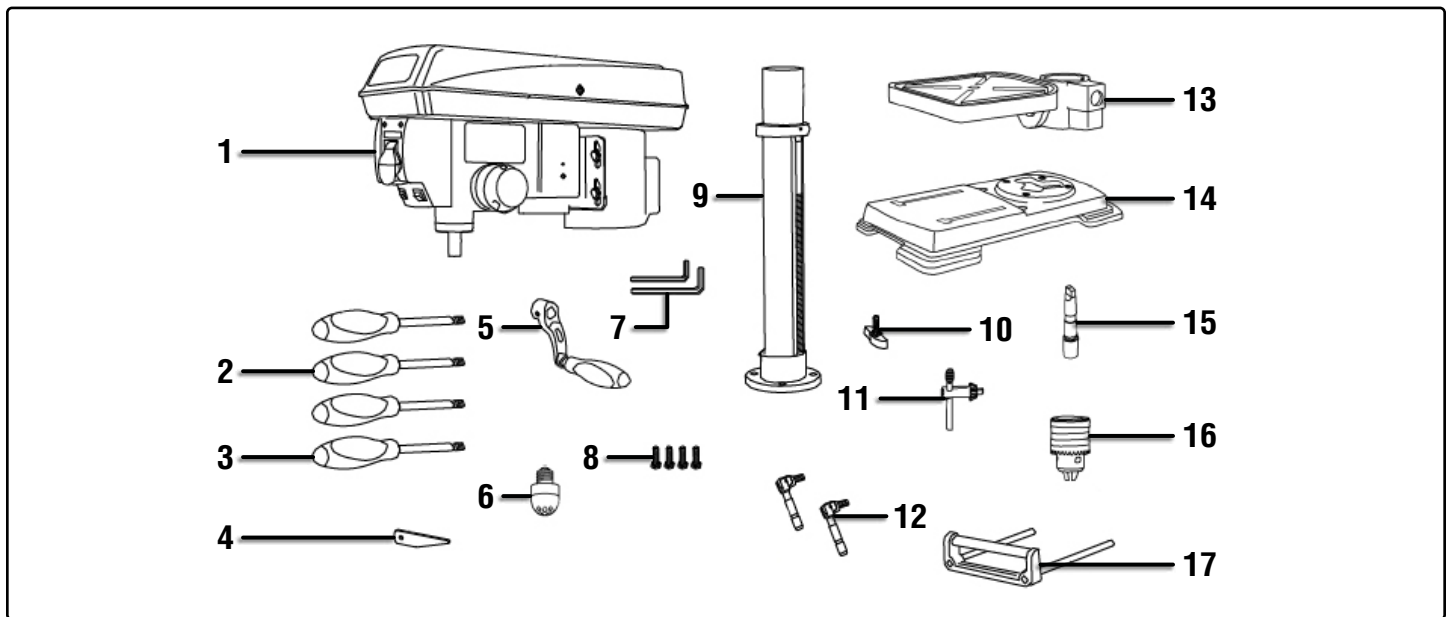

- | | |
|-----------------------------|---|
| 1. Head / Motor Assembly | 10. Wing Knobs (2) |
| 2. Feed Handles (3) | 11. Chuck Key |
| 3. Speed Handle | 12. Table Lock Handles (2) |
| 4. Wedge | 13. Table |
| 5. Table Crank Handle | 14. Base |
| 6. LED Bulb | 15. Chuck Arbor |
| 7. Hex Wrenches (3mm & 4mm) | 16. Chuck |
| 8. Hex Head Bolts (4) | 17. Extension Wing with Integrated Roller |
| 9. Column Assembly | |

ASSEMBLY & ADJUSTMENTS

⚠ WARNING! If any part is missing or damaged, do not plug the drill press in until the missing or damaged part is repaired or replaced.

The column assembly (column, column support, rack, rack collar, and table support bracket) must be attached to the base. The table and table support handles must be attached to the table support bracket. The head must be attached to the column.

Tools needed for assembly (not included):

- Adjustable wrench
- Hammer and block of wood, OR dead blow hammer, OR rubber mallet
- Screwdriver

ATTACHING COLUMN TO BASE (FIG. 3)

1. Place the column assembly (Fig. 3 - 1) on the base (Fig. 3 - 2), aligning the column support holes to the base holes.
2. Install a hex head bolt (Fig. 3 - 3) in each column support hole and tighten bolts using the adjustable wrench (not included).

TABLE TO TABLE SUPPORT BRACKET (FIG. 4)

1. Place the crank handle (Fig 4 - 1) onto the shaft (Fig 4 - 2) of the table bracket so the flat of the shaft is under the set screw (Fig. 4 - 3). Tighten the set screw.
2. Thread the table lock handle (Fig. 4 - 4) into the front of the table support bracket.
3. Thread the table support lock handle into the rear of the table support bracket (not shown).
4. Position the table (Fig. 4 - 5) in the same direction as the base. Install the table and tighten the table lock handle (Fig. 4 - 4) and support lock handle.

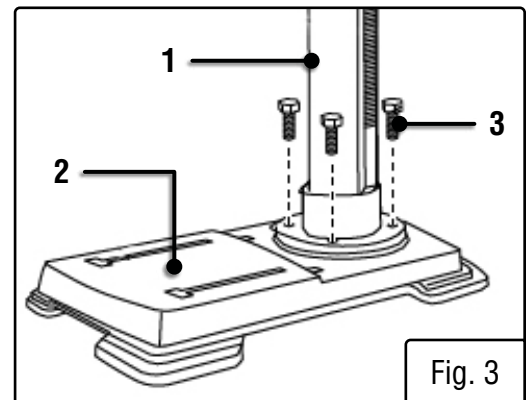

Fig. 3

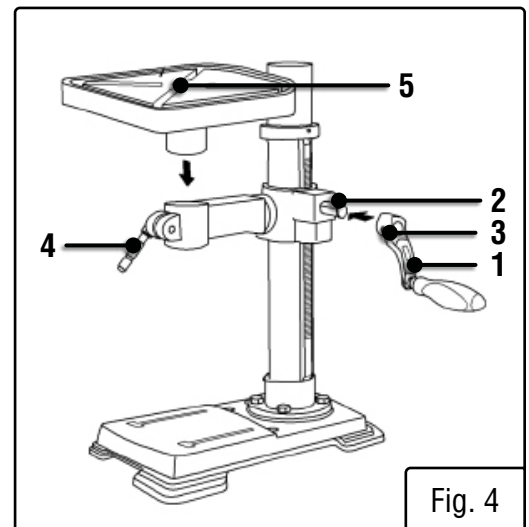

Fig. 4

ASSEMBLY & ADJUSTMENTS

DRILL PRESS HEAD TO COLUMN (FIG. 5)

⚠ WARNING! The drill press head is heavy. To avoid injury, two people should lift it into position.

1. Carefully lift the drill press head assembly (Fig. 5 - 1) and position it over the column (Fig. 5 - 2).
2. Place the mounting opening (Fig. 5 - 3) on the drill press head over the top of the column. Make sure the drill press head is seated properly on the column.
3. Align the direction of the drill press head with the direction of the base and the table.
4. Tighten the set screw (Fig. 5 - 4) using the included hex wrench.

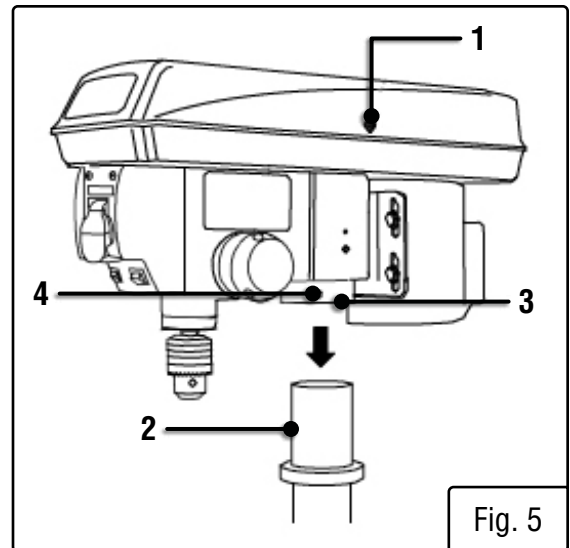

Fig. 5

FEED HANDLES (FIG. 6)

1. Insert the three feed handles (Fig. 6 - 1) into the threaded openings on the feed hub (Fig. 6 - 2).
2. Manually tighten the handles into the openings. Use an adjustable wrench (not included) to grip the flats on the handles and fully tighten them.

NOTE: When using the drill press, one or two of the feed handles may be removed if an unusually-shaped workpiece interferes with the handle rotation.

SPEED HANDLE (FIG. 7)

1. Insert the speed handle (Fig. 7 - 1) into the threaded opening on the speed hub (Fig. 7 - 2).
2. Manually tighten the handle into the openings. Use an adjustable wrench (not included) to grip the flats on the handles and fully tighten them.

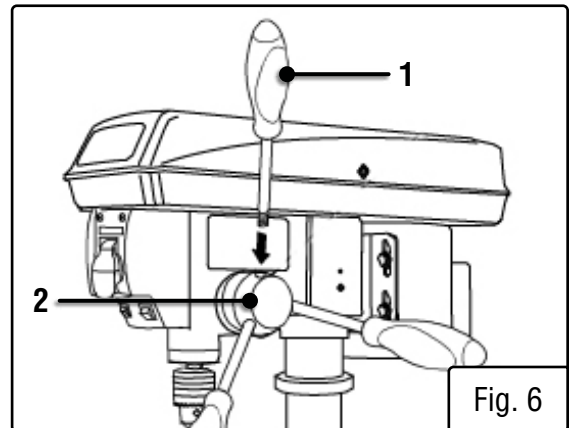

Fig. 6

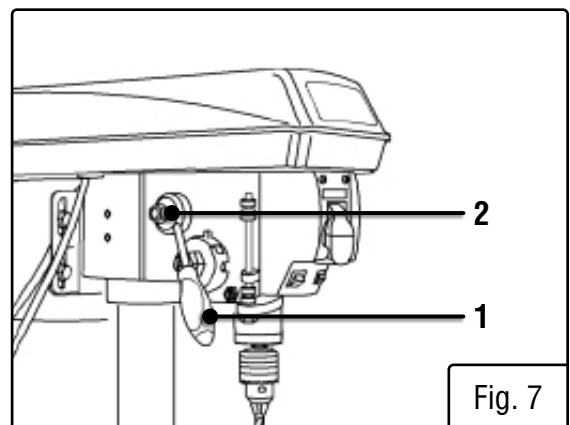

Fig. 7

ASSEMBLY & ADJUSTMENTS

MOUNTING THE DRILL PRESS (FIG. 8)

The drill press must be securely fastened through the mounting holes (Fig. 8 - 1) to a stand or workbench with heavy-duty fasteners (not included). This will prevent the drill press from tipping over, sliding, or walking during operation.

IMPORTANT: If the stand or workbench has a tendency to move during operation, fasten the workbench securely to the floor.

LED BULB

An LED bulb has been assembled in the socket of the head.

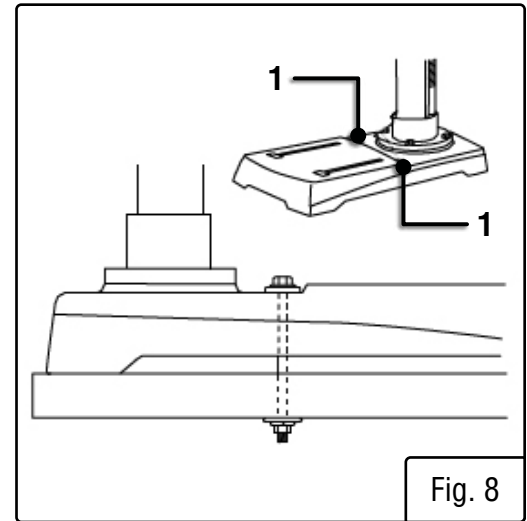

Fig. 8

⚠ WARNING! To reduce risk of fire, DO NOT use a light bulb greater than 40 watts. When changing the light bulb, always check that the power switch is in the OFF position and the plug is disconnected from its power source.

INSTALL THE CHUCK (FIG. 9)

1. Inspect and clean the taper hole in the chuck (Fig. 9 - 1) and the spindle (Fig. 9 - 2). Remove all grease, coatings, and particles from the chuck and spindle surfaces with a clean cloth.

2. Open the chuck jaws (Fig. 9 - 3) by manually turning the chuck barrel clockwise. Make sure the jaws are completely recessed inside the chuck.

3. Insert the chuck arbor (Fig. 9 - 4) into the opening at the top of the chuck.

4. Insert the arbor into the spindle. Rotate it until the tang of the arbor (the flats on the end) is aligned with the slot in the spindle, and the chuck and arbor can be pushed upwards. Seat the chuck by placing a block of wood (Fig. 9 - 5, not included) below the chuck and firmly tapping the wood once with a hammer. Alternatively, firmly tap the chuck once with a rubber mallet or dead-blow hammer (not included).

5. If the chuck or arbor fail to seat properly, they may not be clean enough. Remove them and thoroughly clean the mating surfaces, then try again. Ensure all dust, debris, and liquids are removed from the surfaces, and that neither surface is damaged.

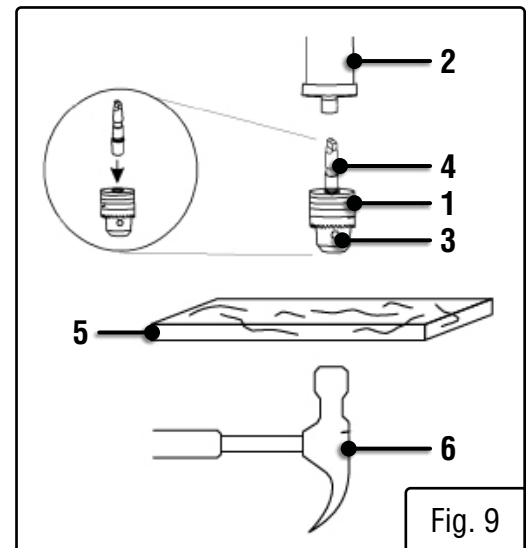

Fig. 9

⚠ CAUTION! To avoid damaging the chuck, make sure the jaws are completely recessed into the chuck. Do not use a metal hammer to drive the chuck onto the arbor or into the spindle.

ASSEMBLY & ADJUSTMENTS

REMOVE THE CHUCK (FIG. 10)

1. Turn the feed handles (1) to lower the chuck (2) to the lowest position.
2. Insert the drift key (3) into the opening in the quill. Gently tap on the wedge using a rubber mallet (4) (not included). The chuck and arbor will drop out.

NOTE: To avoid possible damage to the drill or chuck, be prepared to catch the chuck as it falls.

RAISE OR LOWER THE TABLE (FIG. 11)

1. Loosen the support lock handle (Fig. 11 - 1) and turn the crank handle (Fig. 11 - 2) until the table is at the desired height.
2. Tighten the support lock handle before drilling.

ROTATE THE TABLE (FIG. 11)

1. Loosen the support lock handle (Fig. 11 - 1) and turn the table around the column to the desired position.

NOTE: The rack should rotate around the column with the table support bracket. If the rack binds and does not rotate, slightly loosen the set screw in the rack collar.

2. Tighten the support lock before drilling.

TILT THE TABLE (FIG. 12A)

1. Loosen the bevel lock bolt (Fig. 12A - 1) by turning it counterclockwise with an adjustable wrench (not included).

2. Tilt the table to the desired angle, using the bevel scale (Fig. 12A - 2) as a basic guide.

3. Re-tighten the bevel lock bolt.

ADJUST TABLE TO BE HORIZONTAL (FIG. 12A)

1. Loosen the bevel lock bolt (Fig. 12A - 1).
2. Realign the table to the 0° setting on the bevel scale (Fig. 12A - 2).
3. Tighten the bevel lock bolt with the adjustment wrench.

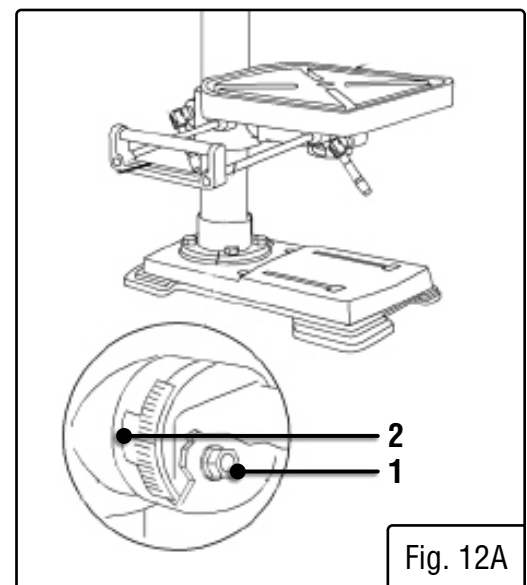
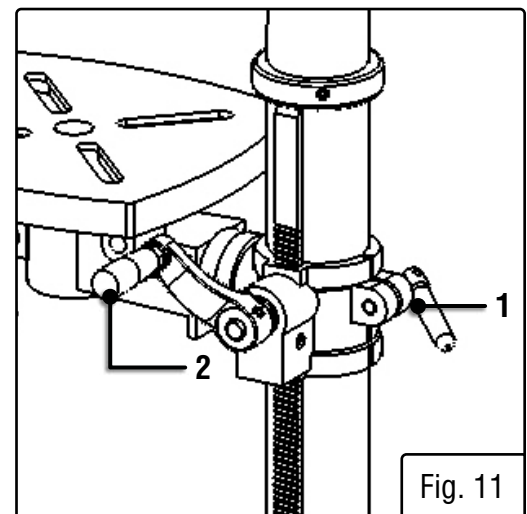
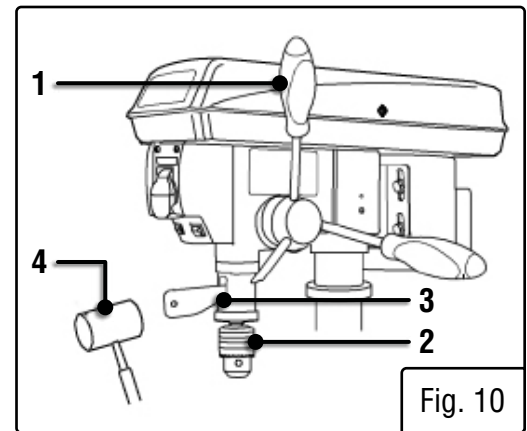

ASSEMBLY & ADJUSTMENTS

INSTALL THE TABLE EXTENSION (FIG. 12B)

1. Insert the two rods (Fig. 12B - 1) of the table extension into the two channels (Fig. 12B - 2) at the side of the table.
2. Place a wing knob (Fig. 12B - 3) in the opening on the bottom of each channel and tighten to secure the extension to the table.

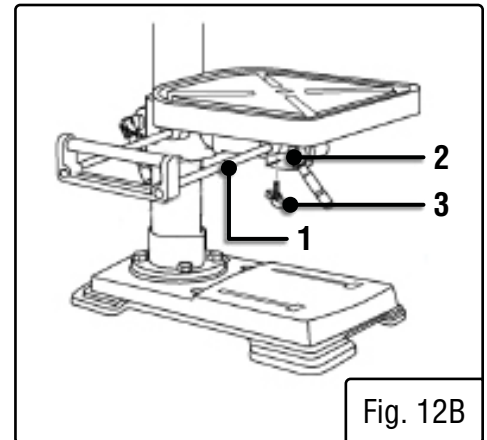

Fig. 12B

⚠ WARNING! To avoid injury, make sure the chuck key is removed from the chuck before starting any drilling operation.

INSTALLING A DRILL BIT (FIG. 13)

1. Place the chuck key (Fig. 13 - 1) into the side keyhole of the chuck (Fig. 13 - 2), meshing the key with the gear teeth.
2. Turn the chuck key counterclockwise to open the chuck jaws (Fig. 13 - 3).
3. Insert a drill bit (Fig. 13 - 4) into the chuck far enough to obtain the maximum grip of the chuck jaws on the bit shank.
4. Center the drill bit in the chuck jaws before the final tightening of the chuck.
5. Tighten the chuck jaws using the chuck key to ensure that the drill bit will not slip while drilling. Tighten all three keyholes on the chuck.
6. Remove the chuck key and place it back on the onboard storage.

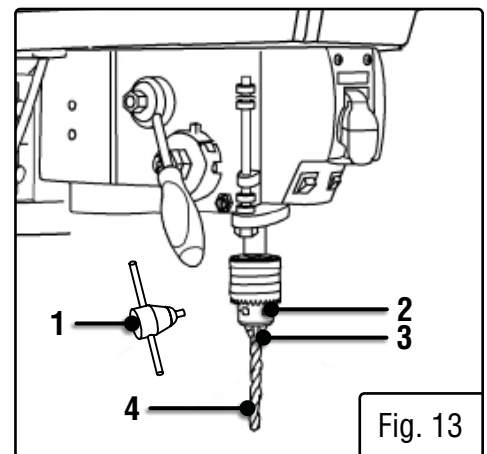

Fig. 13

SQUARING TABLE TO THE DRILL BIT (FIG. 14)

1. Insert a 3" long drill bit (Fig. 14 - 1) into the chuck (Fig. 14 - 2) and tighten the jaws with the chuck key.
2. Raise the table with the crank handle (Fig. 14 - 3). Lock the table (Fig. 14 - 4) approximately 1" below the drill bit.
3. Place a combination square (Fig. 15 - 5) (not included) on the table as shown, placing the long straight edge of the combination square against the drill bit. Make sure the drill bit is parallel / aligned exactly to the straight edge of the square.
4. If an adjustment is needed, loosen the bevel lock bolt (Fig. 14 - 6) with a wrench.
5. Tilt the table slightly, until the combination straight edge is aligned perfectly with the drill bit.
6. Tighten the bevel lock when square.

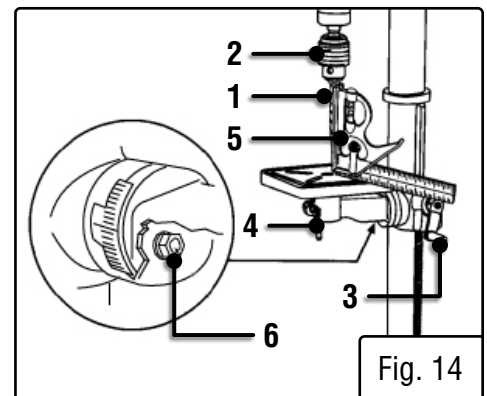

Fig. 14

ASSEMBLY & ADJUSTMENTS

ADJUSTING THE LASER (FIG. 15 & 16)

⚠ WARNING! Do not stare directly at the laser beam. Observe all safety rules.

- Never aim the beam at a person or an object other than the workpiece.
- Always make sure the laser beam is aimed at a workpiece that does not have reflective surfaces, as the laser beam could reflect into your eyes or the eyes of others.

1. Place a workpiece on the table.
2. Turn the laser switch (Fig. 15 - 1) to the ON position.
3. Lower the drill bit to meet the workpiece (Fig. 16 - 2). The two laser lines should cross where the drill meets the workpiece.
- 4. If the laser needs to be adjusted:**
 - a. Using the included 3 mm hex key, turn the laser adjustment set screws (Fig. 15 - 3) counterclockwise. There is one of each side of the head.
 - b. Rotate the laser light housing (Fig. 15 - 4) until the two laser lines intersect where the drill meets the workpiece.
5. Re-tighten the adjustment set screws (Fig. 15 - 3).

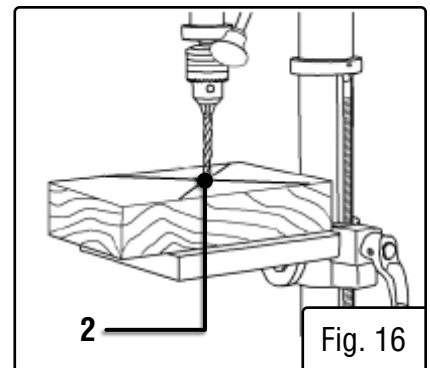
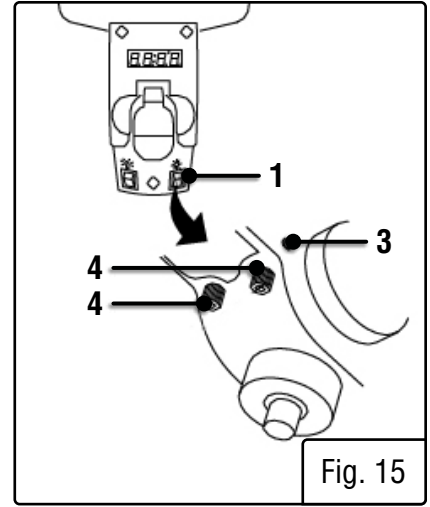

ASSEMBLY & ADJUSTMENTS

SPINDLE RETURN SPRING (FIG. 17)

The spindle is equipped with an auto-return mechanism. The main components are a spring and a notched housing. The spring was properly adjusted at the factory and should not be readjusted unless absolutely necessary.

1. Unplug the drill press.
2. Place a screwdriver into the loop (Fig. 17 - 1) to hold the spring in place.
3. Loosen the two housing nuts (Fig. 17 - 2) approximately 1/4" (6 mm). Do not remove the nuts from the threaded shaft. Do not allow the spring or spring housing to slip out of control.
4. While firmly holding the spring housing (Fig. 17 - 3), carefully pull spring housing out until it clears the raised stop (Fig. 17 - 4).
5. Turn the housing so that the next notch (Fig. 17 - 5) is engaged with the raised stop (Fig. 17 - 4).
 - To increase the spindle return tension, turn the spring housing counter-clockwise.
 - To decrease the tension, turn the spring housing clockwise.
6. Tighten the two housing nuts. Do not overtighten the two nuts. If the nuts are tightened too much, the movement of the spindle and feed handles will become sluggish.

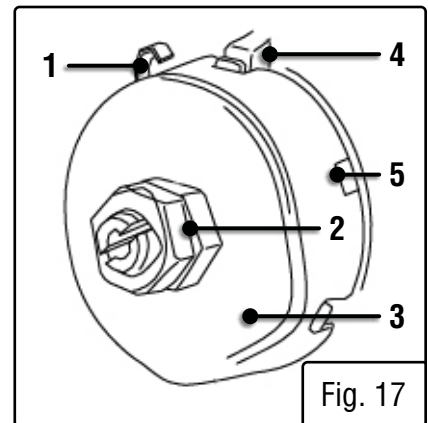

Fig. 17

NOTE: Adjustments for the correct function of your drill press return spring have been done by the factory. Please do not modify them. However, prolonged use of the drill press may make some readjustments necessary.

ANGULAR "PLAY" OF THE SPINDLE (FIG. 18)

Move the spindle to the lowest downward position and hold in place. Try to make the spindle revolve around its axis while also moving it with a side motion. If there is too much "play", proceed as follows:

1. Loosen the outer nut (Fig. 18 - 1) about 1/8 inch.
2. Without obstructing the upward and downward motion of the spindle, turn the screw (Fig. 18 - 2) clockwise to eliminate the "play."

NOTE: A little bit of "play" is normal.

3. Tighten the lock nut (Fig. 18 - 1).

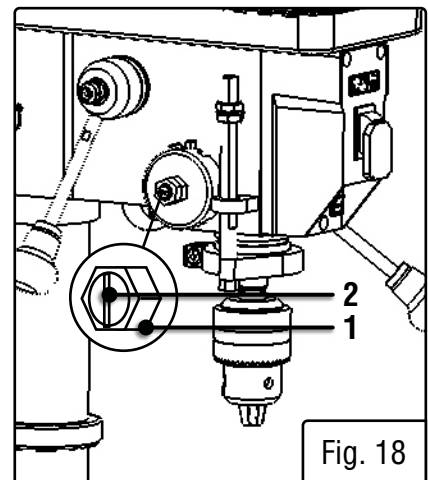

Fig. 18

ASSEMBLY & ADJUSTMENTS

DRILL PRESS ON / OFF SWITCH (FIG. 19)

1. To turn the drill press ON, insert the yellow safety key (Fig. 19 - 1) into the switch housing (Fig. 19 - 2). As a safety feature, the switch cannot be turned ON without the safety key.

2. Flip the switch upward to the ON position.

3. To turn the drill press OFF, flip the switch downward.

4. To lock the switch in the OFF position, remove the safety key (Fig. 19 - 1) from the switch. Store the safety key in a safe place away from the reach of children.

LIGHT & LASER LINE ON/OFF SWITCHES (FIG. 19)

The light switch (Fig. 19 - 3) is located on the lamp cover. The laser switch (Fig. 19 - 4) is located below the ON/OFF switch on the right.

POSITION THE TABLE AND WORKPIECE (FIG. 20)

Always place a piece of backup material (Fig. 20 - 1) (wood, plywood, etc.) on the table underneath the workpiece (Fig. 20 - 2). This will prevent splintering on the underside of the workpiece as the drill bit breaks through. To keep the material from spinning out of control, it must contact the left side (Fig. 20 - 3) of the column as illustrated, or be clamped (Fig. 20 - 4; not included) to the table.

NOTE: For small workpieces that cannot be clamped to the table, use a drill press vise (not included). The vise must be clamped or bolted to the table to avoid injury.

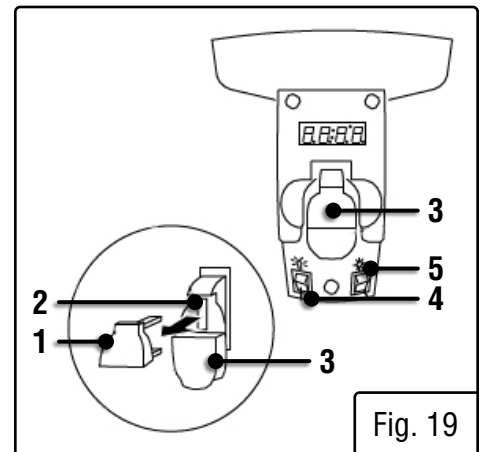

Fig. 19

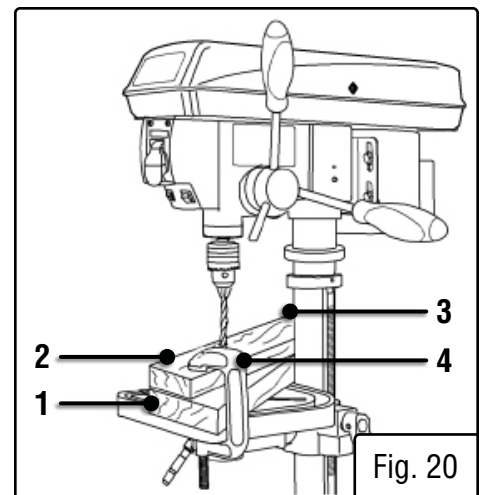

Fig. 20

OPERATION

GENERAL DRILLING GUIDELINES - DRILLING A HOLE

⚠ WARNING! To prevent the workpiece and the backup material from slipping from your hand while drilling, position the workpiece and backup material to the left side of the column. If the workpiece and the backup material are not long enough to reach the column, clamp the workpiece and back material to the table. Failure to do this could result in personal injury.

1. Mark where you want to drill in workpiece by using a center punch or a sharp nail or turn ON the laser to mark your drilling point.
2. Before turning the drill press ON, turn the feed handles to bring the drill bit down. Line the drill bit tip up with the mark. Clamp the workpiece in place.
3. Turn ON the drill press and pull down on the feed handles with the appropriate force needed to allow the drill bit to drill the material.

NOTE: Feeding too slowly might cause the drill bit to turn in the chuck. Feeding too rapidly might stop the motor, cause the belt to slip, force the workpiece loose, or break the drill bit. Practice with scrap material to get the feel of the machine before attempting to do any drilling operation.

ADJUST THE DRILLING DEPTH (FIG. 21A)

The depth gauge controls the maximum distance the drill bit will move up or down.

TO STOP THE DRILL BIT AT A PRE-MEASURED DEPTH:

1. Rotate the lower depth scale knob (Fig. 21A - 2) until the bottom of the knob is aligned with the desired depth mark (Fig. 21A - 5) on the gauge scale.
2. Rotate the depth scale lock knob (Fig. 21A - 1) until it meets the lower depth scale knob (Fig. 21A - 2). The chuck will stop after travelling downward to the selected distance.

TO ADJUST THE QUILL (RETURN) HEIGHT:

To adjust the upward distance the quill (shaft that moves up and down) can travel:

1. Turn the feed handles until the quill is at the desired height and hold it there.
2. Rotate the lower depth knob (Fig. 21A - 3) until it rests against the bottom of the metal gauge support (Fig. 21A - 4).

Drilling an unmeasured blind hole (not all the way through the workpiece) to a given depth can be done two ways: using the depth scale method or workpiece method.

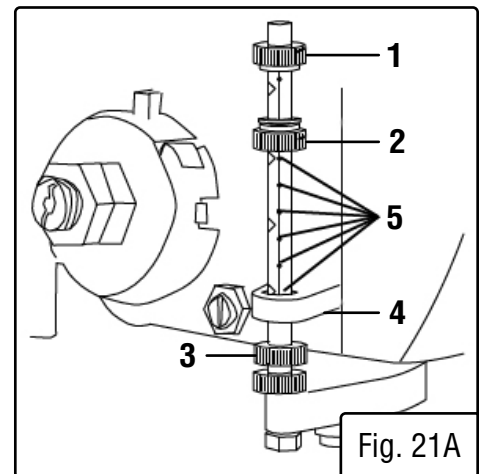

OPERATION

DEPTH SCALE METHOD (FIG. 21B)

1. Make sure the 0 (in or mm) mark on the depth gauge rests at the top edge of the metal support (Fig. 21B - 4) when the quill is fully retracted.
2. Put the workpiece on the table and raise the table until the tip of the drill bit just touches the top of the workpiece. Lock the table in place.
3. Determine the drill depth for this workpiece.
4. Rotate the depth knob (Fig. 21B - 2) until it is aligned with the desired depth mark (Fig. 21B - 3) (for example, 1") on the gauge scale.
5. The chuck will be stopped at the distance selected on the depth scale.

WORKPIECE METHOD (FIG. 21 & 22)

1. Mark the desired depth (Fig. 22 - 5) of the drill hole on the side of the workpiece.
2. With the drill press in the OFF position, bring the drill bit (Fig. 22 - 6) down until the tip is even with the mark.
3. Holding the feed handles at this position, rotate the depth knob (Fig. 21 - 2) until it meets the metal support.
4. The chuck and the drill bit will now be stopped at the distance selected on the depth scale.

DRILLING SPEEDS

There are a few important factors to keep in mind when determining the best drilling speed:

- Material type
- Hole size
- Drill bit or cutter type
- Quality desired

Smaller drill bits require greater speed than larger drill bits. Softer materials require greater speed than harder materials. See page 22 for recommended speeds for particular materials.

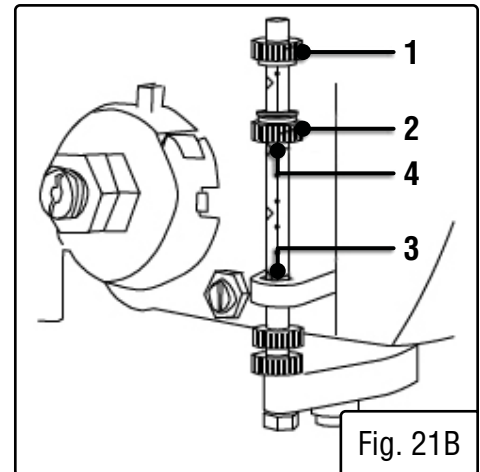

Fig. 21B

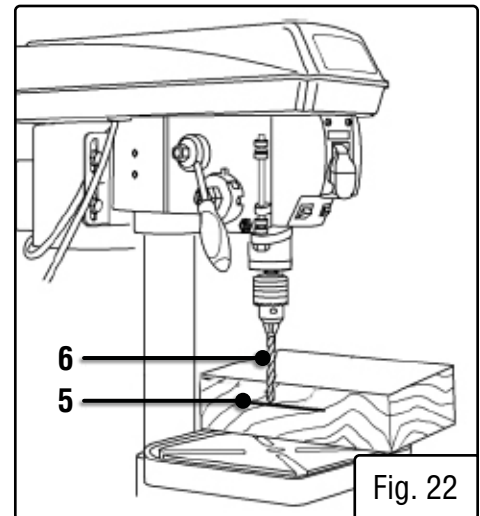

Fig. 22

OPERATION

DRILLING METAL

- Use metal-piercing twist drill bits.
- It is always necessary to lubricate the tip of the drill with oil to prevent overheating of the drill bit.
- All metal workpieces should be clamped down securely. Any tilting, twisting, or shifting causes a rough drill hole, and increases the potential of drill bit breakage.
- Never hold a metal workpiece with your bare hands. The cutting edge of the drill bit may seize the workpiece and throw it, causing serious injury. The drill bit will break if the metal piece suddenly hits the column.
- If the metal is flat, clamp a piece of wood under it to prevent turning. If it cannot be laid flat on the table, then it should be blocked and clamped.

DRILLING WOOD

- Brad point bits are preferred. Metal piercing twist bits may be used on wood.
- Do not use auger bits. Auger bits turn so rapidly that they can lift the workpiece off of the table and whirl it around.
- Always protect the drill bit by positioning the table so that the drill bit will enter the center hole when drilling through the workpiece.
- To prevent splintering, feed the drill bit slowly right as the bit is about to cut through to the backside of the workpiece.
- To reduce splintering and protect the point of the bit, use scrap wood as a backing or a base block under the workpiece.

FEEDING THE DRILL BIT

- Pull down on the feed handles with only enough force to allow the drill bit to cut.
- Feeding too rapidly might stall the motor, cause the belt to slip, damage the workpiece, or break the drill bit.
- Feeding too slowly will cause the drill bit to heat up and burn the workpiece.

MECHANICAL VARIABLE SPEED (FIG. 23)

This is a mechanical variable speed drill press. To increase or decrease the speed when operating, raise or lower the speed handle (Fig. 23 - 1). Use the following table to determine the recommended speed for the drill size you are using and the type of material you are to drill. While drilling, check the speed on the digital speed readout (Fig. 23 - 2) located at the front of the drill press.

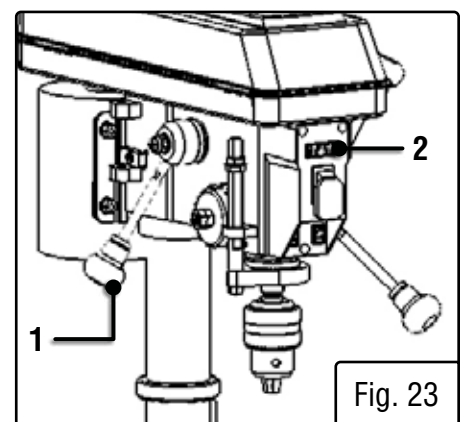

⚠ WARNING! Do not change speeds using the variable speed handle without turning on the machine.

OPERATION

DRILL BIT SIZE RECOMMENDATIONS

RPM	Wood		Aluminum, Zinc, Brass		Iron, Steel	
2000 to 3100	3/8 in.	9.5 mm	7/32 in.	5.6 mm	3/32 in.	2.4 mm
1400 to 2000	5/8 in.	16 mm	11/32 in.	8.75 mm	5/32 in.	4 mm
1000 to 1400	7/8 in.	22 mm	15/32 in.	12 mm	1/4 in.	6.4 mm
800 to 1000	1-1/4 in.	31.75 mm	11/16 in.	17.5 mm	3/8 in.	9.5 mm
580 to 800	1-5/8 in.	41.4 mm	3/4 in.	19 mm	5/8 in.	16 mm

Recommended speed for drill bit size and materials

REPLACING THE BELT (FIG. 24)

⚠ WARNING! Disconnect the drill press from the power source before replacing the belt.

Belt tension and drill press speed is controlled by automatic adjustments made to the diameter of the front spindle when the speed handle is moved.

NOTE: See page 21 for information on the variable speed function of this drill press.

1. Plug in the drill press and turn it ON. Adjust the speed to the highest setting, then turn the drill press OFF and unplug it.
2. Open the belt cover (remove the Phillips-head screw from the right side, then open the lid).
3. Press down on the bottom side of the motor pulley. This will loosen the belt tension. Work the belt off the pulleys.
4. Place the new belt on the motor pulley, then press down on the bottom side of the pulley as before and get the belt as close to the motor shaft as possible. Make sure the bottom side of the pulley is pushed fully downward.
5. Work the belt around the spindle pulley. The belt will not be taut, but will self-seat later.
6. Close and secure the belt cover.
7. Plug in and turn ON the drill press. The belt will self-seat and achieve proper tension on its own.

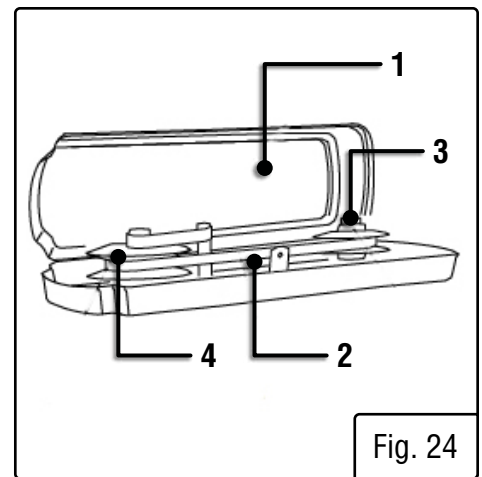

Fig. 24

⚠ WARNING! Do not change the drive speed when the drill press is turned off.

MAINTENANCE

⚠ WARNING! To avoid accidents, turn OFF and unplug the tool from the electrical outlet before cleaning, adjusting, or performing any maintenance or lubrication work.

⚠ WARNING! Any attempt to repair or replace electrical parts on this tool may be hazardous. Servicing of the tool must be performed by a qualified technician. When servicing, use only identical WEN replacement parts. Use of other parts may be hazardous or induce product failure.

ROUTINE INSPECTION

Before each use, inspect the general condition of the tool. If any of these following conditions exist, do not use until parts are replaced.

CHECK FOR:

- Loose hardware or improper mounting,
- Misalignment
- Damaged cord/electrical wiring,
- Cracked or broken parts, and
- Any other condition that may affect its safe operation

CAUTION: Most plastics are susceptible to damage from various types of commercial solvents. Do not use any solvents or cleaning products that could damage the plastic parts. Some of these include but are not limited to: gasoline, carbon tetrachloride, chlorinated cleaning solvents, and household detergents that contain ammonia.

CLEANING & STORAGE

1. After every operation, use a vacuum to remove sawdust or metal shavings from the tool surfaces, motor housing and work area. Keep the ventilation openings free from dust and debris to prevent the motor from overheating.
2. Wipe the tool surfaces clean with a soft cloth or brush. Make sure water does not get into the tool.
3. Apply a light coat of paste wax to the column and table to help keep these surfaces clean and rust free.
4. Store the tool in a clean and dry place away from the reach of children.

LUBRICATION

The ball bearings in the spindle and the V-belt pulley assembly are greased and permanently sealed, and require no lubrication. Pull the spindle down and oil the quill moderately every three months. Periodically lubricate the motor pulley and motor shaft to avoid excessive vibration or speed adjustment failure.

Lubricate the table bracket and locking knobs if they become difficult to use.

PRODUCT DISPOSAL

Used power tools should not be disposed of together with household waste. This product contains electronic components that should be recycled. Please take this product to your local recycling facility for responsible disposal and to minimize its environmental impact.

TROUBLESHOOTING GUIDE

⚠ WARNING! Stop using the tool immediately if any of the following problems occur. Repairs and replacements should only be performed by an authorized technician. For any questions, please contact our customer service at **1-847-429-9263**, M-F 8-5 CST or email us at **techsupport@wenproducts.com**.

PROBLEM	CAUSE	SOLUTION
Noisy Operation or Excessive Vibration	1. Incorrect belt tension.	1. Adjust the belt tension. (See REPLACE THE BELT section)
	2. Dry spindle.	2. Lubricate the spindle.
	3. Loose spindle pulley.	3. Tighten the set screws on the side of the spindle pulley.
	4. Loose motor pulley.	4. Tighten the set screws on the side of the motor pulley.
	5. Seized motor pulley.	5. Lubricate motor pulley and motor shaft; ensure that pulley opens and closes when machine is ON and speed is adjusted.
The drill bit burns or smokes	1. Drilling at the incorrect speed.	1. Change the speed.
	2. The wood chips are not coming out of the hole.	2. Retract the drill bit frequently to clear the chips.
	3. Dull drill bit.	3. Resharpener or replace the drill bit.
	4. Feeding the workpiece too slowly.	4. Feed fast enough to cut the workpiece.
	5. Not lubricated.	5. Lubricate the drill bit with cutting oil or motor oil.
Excessive drill run out or wobble; drilled hole is not round	1. Bent drill bit.	1. Replace the drill bit.
	2. Bit improperly installed in the chuck.	2. Reinstall the bit.
	3. Worn spindle bearings.	3. Bearings may need replacement. Contact customer service at 1-847-429-9263 .
	4. Lengths of cutting flutes or angles not appropriate for the hardness of the wood grain.	4. Resharpener the drill bit correctly or replace with the appropriate type.
	5. Chuck not properly installed.	5. Reinstall the chuck.

TROUBLESHOOTING GUIDE

⚠ WARNING! Stop using the tool immediately if any of the following problems occur. Repairs and replacements should only be performed by an authorized technician. For any questions, please contact our customer service at **1-847-429-9263**, M-F 8-5 CST or email us at **techsupport@wenproducts.com**.

PROBLEM	CAUSE	SOLUTION
Drill bit binds in the workpiece	1. The workpiece is pinching the bit.	1. Support or clamp the workpiece.
	2. Excessive feed pressure.	2. Feed more slowly.
Spindle returns too slowly or too quickly	1. Coil spring has improper tension.	1. Adjust the coil spring tension (see p .17).
Chuck falls off spindle	1. Dirt, grease, or oil on the tapered surface on the spindle or in the chuck.	1. Clean the tapered surface of both the chuck and spindle with a household detergent.
Motor will not run	1. Defective or broken switch.	1. Contact customer service at 1-847-429-9263 .
	2. Defective or damaged power cord.	2. Contact customer service at 1-847-429-9263 .
	3. Open circuit, loose connections, or burned out motor.	3. Contact customer service at 1-847-429-9263 .
	4. Low voltage.	4. Check the power line for the proper voltage. Use another circuit or have a qualified electrician upgrade the service.
	5. Bad starting capacitor.	5. Contact customer service at 1-847-429-9263 .
Motor stalls	1. Short circuit in motor.	1. Contact customer service at 1-847-429-9263 .
	2. Incorrect fuses or circuit breakers.	2. Replace with correct fuse or circuit breaker for the circuit.
	3. Overloaded circuit.	3. Turn off other machines and retry.
	4. Low voltage.	4. Check the power line for the proper voltage. Use another circuit or have a qualified electrician upgrade the service.

EXPLODED VIEW & PARTS LIST

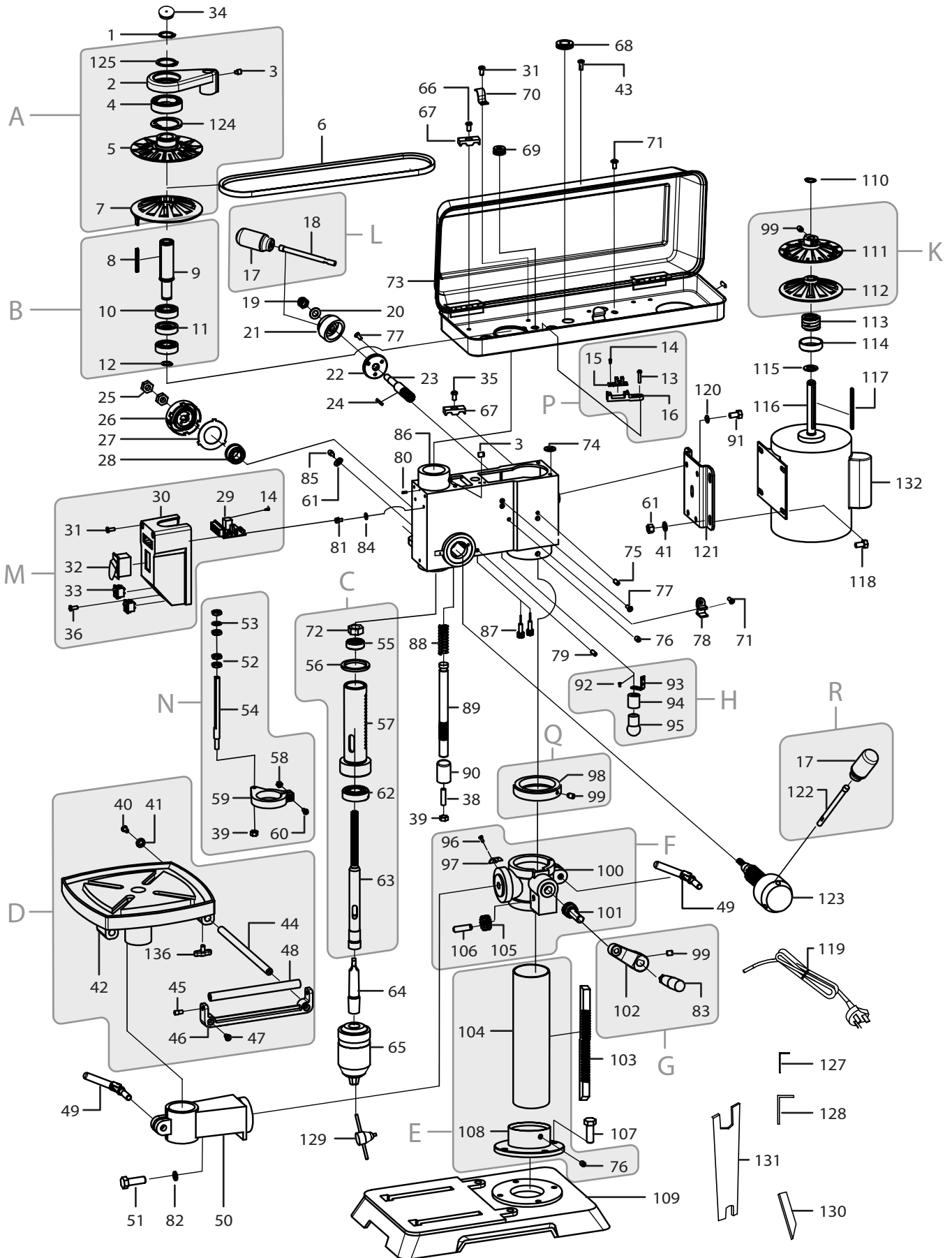

EXPLODED VIEW & PARTS LIST

NOTE: Parts may only be available in their respective subassemblies.
Not all parts may be available for purchase.

NO.	PART NO.	DESCRIPTION	QTY
A - SPINDLE PULLEY ASSEMBLY (PART 4214B-AA)			
2	4214B-002	Cam	1
3	4214B-003	Set Screw, M8x12	1
4	4214B-004	Bearing, 61907	1
5	4214B-005	Spindle Movable Pulley	1
7	4214B-007	Spindle Fixed Pulley	1
124	4214B-124	Elastic Ring, Type A, Ø55	1
125	4214B-125	Circlip for Shaft, Ø35	1
B - SPINDLE SHAFT ASSEMBLY (PART 4214B-AB)			
8	4214B-008	Key, Type A, 4x4x64	1
9	4214B-009	Spindle Sleeve	1
10	4214B-010	Bearing, 6203RZ	2
11	4214B-011	Retainer	1
12	4214B-012	Circlip for Shaft, Ø17	1
C - SPINDLE ASSEMBLY (PART 4214B-AC)			
55	4214B-055	Bearing, 6201RZ	1
56	4214B-056	Rubber Washer	1
57	4214B-057	Quill	1
62	4214B-062	Bearing, 6204RZ	1
63	4214B-063	Spindle, MT2	1
72	4214B-1109	Hex Nut, M14	1
D - TABLE ASSEMBLY (PART 4214B-AD)			
40	4214B-079	Phillips-Head Screw, M6x8	1
41	4214B-041	Flat Washer, Ø8	4
42	4214B-042	Work Table	1
44	4214B-044	Guide Rod	2
45	4214B-045	Roller Screw	2
46	4214B-046	Roller Support	1
47	4214B-047	Phillips-Head Screw, M6x12	2
48	4214B-048	Roller	1
E - COLUMN ASSEMBLY (PART 4214B-AE)			
76	4214B-076	Set Screw, M8x8	1
104	4214B-104	Column	1
108	4214B-108	Column Base	1
F - TABLE SUPPORT ASSEMBLY (PART 4214B-AF)			
96	4214B-096	Phillips-Head Screw, M4x8	2
97	4214B-097	Bevel Indicator	1
100	4214B-100	Table Support	1
101	4214B-101	Worm Gear	1
105	4214B-105	Inner Gear	1
106	4214B-106	Inner Gear Shaft	1

NO.	PART NO.	DESCRIPTION	QTY
G - CRANK ASSEMBLY (PART 4214B-AG)			
83	4214B-129	Handle	1
99	4214B-1099	Screw M6x10	3
102	4214B-102	Crank Handle	1
H - LAMP ASSEMBLY (PART 4214B-AH)			
92	4214B-1092	Phillips-Head Screw, M4x12	1
93	4214B-093	Lamp Socket Bracket	1
94	4214B-094	Lamp Socket	1
95	4214B-095	LED Lamp	1
K - MOTOR PULLEY ASSEMBLY (PART 4214B-AK)			
99	4214B-1099	Screw M6x10	1
111	4214B-111	Motor Fixed Pulley	1
112	4214B-112	Motor Movable Pulley	1
L - VARIABLE SPEED HANDLE ASSEMBLY (PART 4214B-AL)			
17	4214B-017	Handle Knob	1
18	4214B-018	Variable Speed Handle	1
M - SWITCHBOX ASSEMBLY (PART 4214B-AM)			
14	4214B-014	Screw, ST2.9x6.5	4
29	4214B-029-01	Digital Display PCB	1
30	4214B-030	Switch Box	1
31	4214B-031	Phillips-Head Screw, M5X12	3
32	4214B-032	Main Switch	1
33	4214B-033	Lamp/Laser Switch	2
36	4214B-077	Phillips-Head Screw, M5X10	1
N - SCALE COLLAR ASSEMBLY (PART 4214B-AN)			
39	4214B-061	Hex Nut, M8	1
52	4214B-052	Adjustment Nut	4
53	4214B-053	Special Washer	1
54	4214B-054	Scale	1
58	4214B-058	Nut M6	1
59	4214B-059	Scale Collar	1
60	4214B-060	Screw M6x16	1
P - SPEED SENSOR ASSEMBLY (PART 4214B-AP)			
13	4214B-013	Screw, M4x20	2
14	4214B-014	Screw, ST2.9x6.5	2
15	4214B-015	Speed Sensor	1
16	4214B-016	Speed Sensor Base	1
Q - RACK COLLAR ASSEMBLY (PART 4214B-AQ)			
98	4214B-098	Rack Collar	1
99	4214B-1099	Screw M6x10	1
R - SPINDLE HANDLE ASSEMBLY (PART 4214B-AR)			
17	4214B-017	Handle Knob	3
122	4214B-122	Handle	3

EXPLODED VIEW & PARTS LIST

NO.	PART NO.	DESCRIPTION	QTY
1	4214B-001	Circlip for Shaft, Ø24	1
6	4214B-006	Cogged V-belt, 10x900	1
19	4214B-019	Lock Nut, M10	1
20	4214B-020	Flat Washer, Ø10	1
21	4214B-021	Handle Seat	1
22	4214B-022	Speed Adjustment Base	1
23	4214B-023	Gear Shaft	1
24	4214B-024	Key, Type A, 3x3x25	1
25	4214B-025	Hex Nut, M12	2
26	4214B-026	Coil Spring Assembly	1
27	4214B-027	Spring Baffle	1
28	4214B-028	Bushing	1
34	4214B-1001	Shaft Cover	1
35	4214B-079	Phillips-Head Screw, M6x10	1
37	4214B-136	Knob	2
38	4214B-1089	Inner Hex Bolt, M8x6	1
43	4214B-066	Screw, M5x12	1
49	4214B-049	Column Clamp	1
50	4214B-050	Table Arm	1
51	4214B-051	Hex Bolt, M12x35	1
61	4214B-061	Hex Nut, M8	5
64	4214B-064	Chuck Arbor, MT2-JT3	1
65	4214B-065	Chuck, JT3	1
66	4214B-072	Screw, M5x16	1
67	4214B-067	Cord Clamping Plate	2
68	4214B-068	Rubber Bushing	2
69	4214B-069	Cord Bushing	1
70	4214B-070	Cord Clamping Hook	1
72	4214B-1109	Hex Nut, M14	1
73	4214B-073	Belt Housing Assembly	1
74	4214B-074	Damping Pad	4
75	4214B-075	Spring Pin, 6x15	2
77	4214B-077	Phillips-Head Screw, M5x10	5
78	4214B-078	Wrench Clip	1

NO.	PART NO.	DESCRIPTION	QTY
79	4214B-079	Screw M6x8	2
80	4214B-080	Pin	1
81	4214B-081	Phillips-Head Screw, M5x8, with Spring & Flat Washers	2
82	4214B-1128	Spring Washer, M12	1
84	4214B-084	Star Washer Ø5	2
85	4214B-085	Quill Set Screw	1
86	4214B-086	Head	1
87	4214B-087	Laser	2
88	4214B-088	Rack Compression Spring	1
89	4214B-1089	Rack Shaft	1
90	4214B-1085	Rack Bushing	1
91	4214B-091	Hex Bolt M8*12	3
103	4214B-103	Rack	1
107	4214B-107	Hex Bolt, M10x30	4
109	4214B-109	Base	1
110	4214B-110	Circlip for Shaft, Ø14	1
113	4214B-113	Motor Compression Spring	1
114	4214B-114	Spring Base	1
115	4214B-115	Spring Washer	1
116	4214B-116	Motor Assembly	1
117	4214B-117	Key, Type A, 4x4x80	1
118	4214B-118	Hex Screw, M8x16	4
119	4214B-119	Power Cord	1
120	4214B-120	Spring Washer, Ø8	3
121	4214B-121	Motor Plate	1
123	4214B-123	Handle Hub	1
126	4214B-131	Sealing Rubber Strip	4
127	4214B-132	Hex Wrench, M3	1
128	4214B-133	Hex Wrench, M4	1
129	4214B-134	Chuck Key	1
130	4214B-135	Wedge Block	1
131	4214B-1096	Wrench	1
NP	4214B-116-1	Capacitor	1
132	4214B-116CC	Capacitor Cover	1
136	4214B-136	Table Support Knob	2

WARRANTY STATEMENT

WEN Products is committed to building tools that are dependable for years. Our warranties are consistent with this commitment and our dedication to quality.

LIMITED WARRANTY OF WEN CONSUMER POWER TOOLS PRODUCTS FOR HOME USE

GREAT LAKES TECHNOLOGIES, LLC (“Seller”) warrants to the original purchaser only, that all WEN consumer power tools will be free from defects in material or workmanship for a period of two (2) years from date of purchase. Ninety days for all WEN products if the tool is used for professional or commercial use.

SELLER’S SOLE OBLIGATION AND YOUR EXCLUSIVE REMEDY under this Limited Warranty and, to the extent permitted by law, any warranty or condition implied by law, shall be the repair or replacement of parts, without charge, which are defective in material or workmanship and which have not been misused, carelessly handled, or misrepaired by persons other than Seller or Authorized Service Center. To make a claim under this Limited Warranty, you must make sure to keep a copy of your proof of purchase that clearly defines the Date of Purchase (month and year) and the Place of Purchase. Place of purchase must be a direct vendor of Great Lakes Technologies, LLC. Third party vendors such as garage sales, pawn shops, resale shops, or any other secondhand merchant void the warranty included with this product. Contact techsupport@wenproducts.com or 1-847-429-9263 to make arrangements for repairs and transportation.

When returning a product for warranty service, the shipping charges must be prepaid by the purchaser. The product must be shipped in its original container (or an equivalent), properly packed to withstand the hazards of shipment. The product must be fully insured with a copy of the warranty card and/or the proof of purchase enclosed. There must also be a description of the problem in order to help our repairs department diagnose and fix the issue. Repairs will be made and the product will be returned and shipped back to the purchaser at no charge.

THIS LIMITED WARRANTY DOES NOT APPLY TO ACCESSORY ITEMS THAT WEAR OUT FROM REGULAR USAGE OVER TIME INCLUDING BELTS, BRUSHES, BLADES, ETC. ANY IMPLIED WARRANTIES SHALL BE LIMITED IN DURATION TO TWO (2) YEARS FROM DATE OF PURCHASE. SOME STATES IN THE U.S., SOME CANADIAN PROVINCES DO NOT ALLOW LIMITATIONS ON HOW LONG AN IMPLIED WARRANTY LASTS, SO THE ABOVE LIMITATION MAY NOT APPLY TO YOU.

IN NO EVENT SHALL SELLER BE LIABLE FOR ANY INCIDENTAL OR CONSEQUENTIAL DAMAGES (INCLUDING BUT NOT LIMITED TO LIABILITY FOR LOSS OF PROFITS) ARISING FROM THE SALE OR USE OF THIS PRODUCT. SOME STATES IN THE U.S. AND SOME CANADIAN PROVINCES DO NOT ALLOW THE EXCLUSION OR LIMITATION OF INCIDENTAL OR CONSEQUENTIAL DAMAGES, SO THE ABOVE LIMITATION OR EXCLUSION MAY NOT APPLY TO YOU.

THIS LIMITED WARRANTY GIVES YOU SPECIFIC LEGAL RIGHTS, AND YOU MAY ALSO HAVE OTHER RIGHTS WHICH VARY FROM STATE TO STATE IN THE U.S., PROVINCE TO PROVINCE IN CANADA AND FROM COUNTRY TO COUNTRY.

THIS LIMITED WARRANTY APPLIES ONLY TO PORTABLE ELECTRIC TOOLS, BENCH POWER TOOLS, OUTDOOR POWER EQUIPMENT AND PNEUMATIC TOOLS SOLD WITHIN THE UNITED STATES OF AMERICA, CANADA AND THE COMMONWEALTH OF PUERTO RICO. FOR WARRANTY COVERAGE WITHIN OTHER COUNTRIES, CONTACT THE WEN CUSTOMER SUPPORT LINE.

**THANKS FOR
REMEMBERING**  **WEN**[®]