

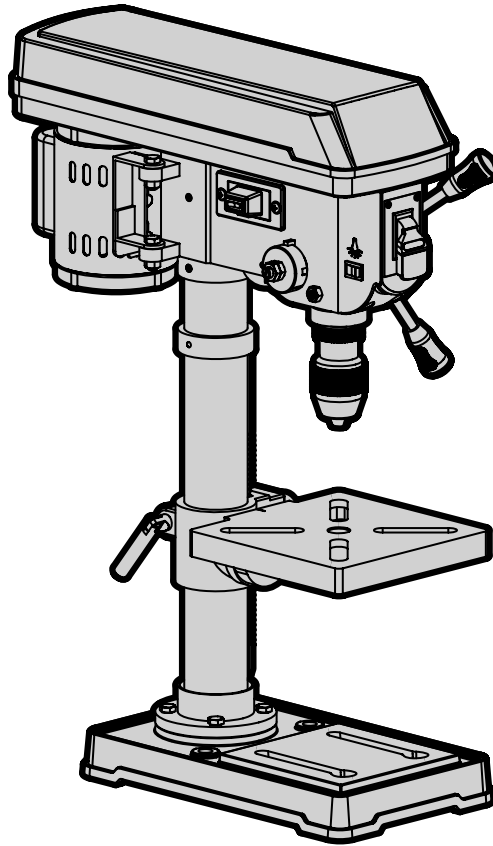

MODEL 4211

10-INCH DRILL PRESS WITH LASER CROSSHAIR

Instruction Manual



NEED HELP? CONTACT US!

Have product questions? Need technical support? Please feel free to contact us:



1-800-232-1195 (M-F 8AM-5PM CST)



TECHSUPPORT@WENPRODUCTS.COM

IMPORTANT: Your new tool has been engineered and manufactured to WEN's highest standards for dependability, ease of operation, and operator safety. When properly cared for, this product will supply you years of rugged, trouble-free performance. Pay close attention to the rules for safe operation, warnings, and cautions. If you use your tool properly and for its intended purpose, you will enjoy years of safe, reliable service.

For replacement parts and the most up-to-date instruction manuals, visit ***WENPRODUCTS.COM***

CONTENTS

WELCOME	3
Introduction	3
Specifications.....	3
SAFETY	4
General Safety Rules	4
Drill Press Safety Warnings	6
Electrical Information	8
BEFORE OPERATING	9
Know Your Drill Press	9
Unpacking & Packing List	10
Assembly & Adjustments.....	11
OPERATION & MAINTENANCE	19
Operation	19
Maintenance.....	21
Troubleshooting Guide	22
Exploded View & Parts List.....	24
Warranty Statement	27

To purchase accessories and replacement parts for your tool, visit **WENPRODUCTS.COM**

Drill Press Table (Model DPA2513 and DPA2412T)

Impact-Duty Titanium Step Drill Bit Set (Model DB238X, DB149X, and DP124X)

Forstner Bit Set (Model FB3508, FB5114)

Drill Press Clamp (Model 429DPC, 426DPC, and 430DPC)

Drill Press Vise (Model DPA423 and DPA424)

INTRODUCTION

Thanks for purchasing the WEN Drill Press. We know you are excited to put your tool to work, but first, please take a moment to read through the manual. Safe operation of this tool requires that you read and understand this operator's manual and all the labels affixed to the tool. This manual provides information regarding potential safety concerns, as well as helpful assembly and operating instructions for your tool.

 Indicates danger, warning, or caution. The safety symbols and the explanations with them deserve your careful attention and understanding. Always follow the safety precautions to reduce the risk of fire, electric shock or personal injury. However, please note that these instructions and warnings are not substitutes for proper accident prevention measures.

NOTE: The following safety information is not meant to cover all possible conditions and situations that may occur. WEN reserves the right to change this product and specifications at any time without prior notice.

At WEN, we are continuously improving our products. If you find that your tool does not exactly match this manual, please visit wenproducts.com for the most up-to-date manual or contact our customer service at **1-800-232-1195**.

Keep this manual available to all users during the entire life of the tool and review it frequently to maximize safety for both yourself and others.

SPECIFICATIONS

Model Number	4211
Motor	120V, 60 Hz, 3.2A
Chuck Capacity	1/2 Inch
Spindle Stroke	2-1/2 Inches
Spindle Taper	JT33
Speeds	600, 1100, 1700, 2400, 3100 RPM
Swing	10 Inches
Table Size	7-5/8 in. x 7-5/8 in.
Base Size	13-1/8 in. x 8-1/8 in.
Column Diameter	2-1/4 Inches
Total Height	26-1/2 Inches
Laser	Class II, 650nm, 1mW
Weight	51 Pounds

GENERAL SAFETY RULES

⚠ WARNING! Read all safety warnings and all instructions. Failure to follow the warnings and instructions may result in electric shock, fire and/or serious injury.

Safety is a combination of common sense, staying alert and knowing how your item works. The term “power tool” in the warnings refers to your mains-operated (corded) power tool or battery-operated (cordless) power tool.

SAVE THESE SAFETY INSTRUCTIONS.

WORK AREA SAFETY

- 1. Keep work area clean and well lit.** Cluttered or dark areas invite accidents.
- 2. Do not operate power tools in explosive atmospheres, such as in the presence of flammable liquids, gases or dust.** Power tools create sparks which may ignite the dust or fumes.
- 3. Keep children and bystanders away while operating a power tool.** Distractions can cause you to lose control.

ELECTRICAL SAFETY

- 1. Power tool plugs must match the outlet. Never modify the plug in any way. Do not use any adapter plugs with earthed (grounded) power tools.** Unmodified plugs and matching outlets will reduce risk of electric shock.
- 2. Avoid body contact with earthed or grounded surfaces such as pipes, radiators, ranges and refrigerators.** There is an increased risk of electric shock if your body is earthed or grounded.
- 3. Do not expose power tools to rain or wet conditions.** Water entering a power tool will increase the risk of electric shock.
- 4. Do not abuse the cord. Never use the cord for carrying, pulling or unplugging the power tool. Keep cord away from heat, oil, sharp edges or moving parts.** Damaged or entangled cords increase the risk of electric shock.
- 5. When operating a power tool outdoors, use an extension cord suitable for outdoor use.** Use of a cord suitable for outdoor use reduces the risk of electric shock.

- 6. If operating a power tool in a damp location is unavoidable, use a ground fault circuit interrupter (GFCI) protected supply.** Use of a GFCI reduces the risk of electric shock.

PERSONAL SAFETY

- 1. Stay alert, watch what you are doing and use common sense when operating a power tool. Do not use a power tool while you are tired or under the influence of drugs, alcohol or medication.** A moment of inattention while operating power tools may result in serious personal injury.
- 2. Use personal protective equipment. Always wear eye protection.** Protective equipment such as a respiratory mask, non-skid safety shoes and hearing protection used for appropriate conditions will reduce the risk of personal injury.
- 3. Prevent unintentional starting. Ensure the switch is in the off-position before connecting to power source and/or battery pack, picking up or carrying the tool.** Carrying power tools with your finger on the switch or energizing power tools that have the switch on invites accidents.
- 4. Remove any adjusting key or wrench before turning the power tool on.** A wrench or a key left attached to a rotating part of the power tool may result in personal injury.
- 5. Do not overreach. Keep proper footing and balance at all times.** This enables better control of the power tool in unexpected situations.
- 6. Dress properly. Do not wear loose clothing or jewelry. Keep your hair and clothing away from moving parts.** Loose clothes, jewelry or long hair can be caught in moving parts.

GENERAL SAFETY RULES

 **WARNING!** Read all safety warnings and all instructions. Failure to follow the warnings and instructions may result in electric shock, fire and/or serious injury.

Safety is a combination of common sense, staying alert and knowing how your item works. The term “power tool” in the warnings refers to your mains-operated (corded) power tool or battery-operated (cordless) power tool.

SAVE THESE SAFETY INSTRUCTIONS.

7. If devices are provided for the connection of dust extraction and collection facilities, ensure these are connected and properly used. Use of dust collection can reduce dust-related hazards.

POWER TOOL USE AND CARE

1. Do not force the power tool. Use the correct power tool for your application. The correct power tool will do the job better and safer at the rate for which it was designed.

2. Do not use the power tool if the switch does not turn it on and off. Any power tool that cannot be controlled with the switch is dangerous and must be repaired.

3. Disconnect the plug from the power source and/or the battery pack from the power tool before making any adjustments, changing accessories, or storing power tools. Such preventive safety measures reduce the risk of starting the power tool accidentally.

4. Store idle power tools out of the reach of children and do not allow persons unfamiliar with the power tool or these instructions to operate the power tool. Power tools are dangerous in the hands of untrained users.

5. Maintain power tools. Check for misalignment or binding of moving parts, breakage of parts and any other condition that may affect the power tool's operation. If damaged, have the power tool repaired before use. Many accidents are caused by poorly maintained power tools.

6. Keep cutting tools sharp and clean. Properly maintained cutting tools with sharp cutting edges are less likely to bind and are easier to control.

7. Use the power tool, accessories and tool bits, etc. in accordance with these instructions, taking into account the working conditions and the work to be performed. Use of the power tool for operations different from those intended could result in a hazardous situation.

8. Use clamps to secure your workpiece to a stable surface. Holding a workpiece by hand or using your body to support it may lead to loss of control.

9. KEEP GUARDS IN PLACE and in working order.

SERVICE

1. Have your power tool serviced by a qualified repair person using only identical replacement parts. This will ensure that the safety of the power tool is maintained.

CALIFORNIA PROPOSITION 65 WARNING

Some dust created by power sanding, sawing, grinding, drilling, and other construction activities may contain chemicals, including lead, known to the State of California to cause cancer, birth defects, or other reproductive harm. Wash hands after handling. Some examples of these chemicals are:

- Lead from lead-based paints.
- Crystalline silica from bricks, cement, and other masonry products.
- Arsenic and chromium from chemically treated lumber.

Your risk from these exposures varies depending on how often you do this type of work. To reduce your exposure to these chemicals, work in a well-ventilated area with approved safety equipment such as dust masks specially designed to filter out microscopic particles.

DRILL PRESS SAFETY WARNINGS

⚠ WARNING! Do not let comfort or familiarity with the product replace strict adherence to product safety rules. Failure to follow the safety instructions may result in serious personal injury.

DRILL PRESS SAFETY

1. TOOL PURPOSE. This drill press is designed to drill through metal and wood. Drilling through other materials could result in fire, injury, or damage to the workpiece. Using the machine for any other purpose for which it is not designed may result in serious injuries, machine damage and voiding of the warranty.

2. MACHINE MOUNTING. For operation safety, the drill press must be securely mounted onto a flat and stable surface or stand.

3. PERSONAL SAFETY.

- Always wear ANSI Z87.1-approved glasses with side shields, hearing protection and a dust mask.
- Do not wear loose clothing or jewelry, as they might get drawn in by the tool. Tie back long hair.
- DO NOT wear gloves while operating this machine.

4. ELECTRIC CORDS. Keep cords away from heat, oil, sharp edges, and moving parts of the tool. Have an electrician replace or repair damaged or worn cords immediately.

5. TOOL & ACCESSORIES INSPECTION. Before operation, check the tool and accessories for any damage or missing parts. Do not use the tool if any part is missing or damaged. Make sure all adjustments are correct and all connections are tight. Keep all guards in place.

6. DRILLING ACCESSORIES.

- Make sure the drill bit is not damaged before use; only use undamaged drill bits
- Make sure the drill bit is securely locked in the chuck before turning ON.
- Make sure the chuck key is removed from the chuck before turning ON.
- Use clamps or a vise (not included) to secure a workpiece to the table. This will prevent the workpiece from rotating with the drill bit.

7. Make sure the table lock is tightened before starting the drill press.

8. WORKPIECE REQUIREMENTS.

- Only stand workpieces sturdy enough to withstand the force of the drill bit.
- Inspect the workpiece for imperfections, nails, staples, etc. before drilling. Never drill stock that has questionable imperfections or embedded foreign objects.
- Do not drill materials without a flat surface unless a suitable support is used (clamp or vise).

9. PREVENTING ACCIDENTAL STARTING. Make sure the power switch is in the OFF position prior to plugging in the machine. Always make sure the power switch is in the OFF position and the machine is unplugged when doing any cleaning, assembly, setup operations, or when not in use.

10. Do not operate this tool until it is completely assembled and installed according to the instructions.

11. Remove scrap pieces and other objects from the table before turning ON the drill press.

DRILL PRESS SAFETY WARNINGS

⚠ WARNING! Do not let comfort or familiarity with the product replace strict adherence to product safety rules. Failure to follow the safety instructions may result in serious personal injury.

12. DRILLING THE WORKPIECE.

- Allow spindle to reach full speed before drilling the workpiece.
- Never start the machine with the drill bit pressed against the workpiece.
- Adjust the table or depth stop to avoid drilling into the table.
- Set the drill press to the speed that is appropriate for the material being drilled.

13. DO NOT TOUCH MOVING PIECES. Keep hands away from the drill bit during operation. If cleaning is necessary, turn off the machine and use a brush to remove sawdust and chips instead of your hands.

14. Never perform layout, assembly or set-up work on the table while the machine is ON.

15. After turning off the drill press, wait until the spindle comes to a complete stop before touching the workpiece. Always turn the drill OFF before removing scrap from the table.

16. Before leaving the machine, always turn OFF and unplug the machine, remove the drill bit, and clean the table. Turn Off and unplug the machine before cleaning, making adjustments or changing drill bits. Accidental start-ups may occur if the tool is plugged in during an accessory change or adjustment.

17. CLEANING. Never use solvents to clean plastic parts. Solvents could dissolve or otherwise damage the material. Use only a soft damp cloth to clean plastic parts.

18. REPLACEMENTS. Should any component of your drill press be missing/damaged or fail in any way, shut OFF the switch and remove the plug from power supply outlet. Replace the missing, damaged, or failed parts using only identical replacement parts before resuming operation.

CALIFORNIA PROPOSITION 65 WARNING

Some dust created by power sanding, sawing, grinding, drilling, and other construction activities may contain chemicals, including lead, known to the State of California to cause cancer, birth defects, or other reproductive harm. Wash hands after handling. Some examples of these chemicals are:

- Lead from lead-based paints.
- Crystalline silica from bricks, cement, and other masonry products.
- Arsenic and chromium from chemically treated lumber.

Your risk from these exposures varies depending on how often you do this type of work. To reduce your exposure to these chemicals, work in a well-ventilated area with approved safety equipment such as dust masks specially designed to filter out microscopic particles.

These safety instructions can't possibly warn of every scenario that may arise with this tool, so always make sure to stay alert and use common sense during operation.

ELECTRICAL INFORMATION

GROUNDING INSTRUCTIONS

In the event of a malfunction or breakdown, grounding provides the path of least resistance for an electric current and reduces the risk of electric shock. This tool is equipped with an electric cord that has an equipment grounding conductor and a grounding plug. The plug **MUST** be plugged into a matching outlet that is properly installed and grounded in accordance with ALL local codes and ordinances.

1. Do not modify the plug provided. If it will not fit the outlet, have the proper outlet installed by a licensed electrician.

2. Improper connection of the equipment grounding conductor can result in electric shock. The conductor with the green insulation (with or without yellow stripes) is the equipment grounding conductor. If repair or replacement of the electric cord or plug is necessary, **DO NOT** connect the equipment grounding conductor to a live terminal.

3. Check with a licensed electrician or service personnel if you do not completely understand the grounding instructions or whether the tool is properly grounded.

4. Use only three-wire extension cords that have three-pronged plugs and outlets that accept the tool's plug. Repair or replace a damaged or worn cord immediately.

CAUTION! In all cases, make certain the outlet in question is properly grounded. If you are not sure, have a licensed electrician check the outlet.

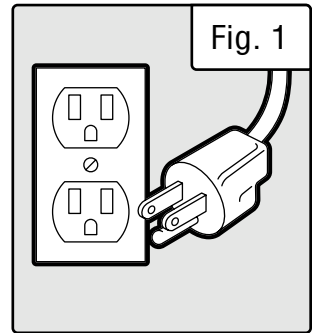

GUIDELINES AND RECOMMENDATIONS FOR EXTENSION CORDS

When using an extension cord, be sure to use one heavy enough to carry the current your product will draw. An undersized cord will cause a drop in line voltage resulting in loss of power and overheating. The table below shows the correct size to be used according to cord length and ampere rating. When in doubt, use a heavier cord. The smaller the gauge number, the heavier the cord.

AMPERAGE	REQUIRED GAUGE FOR EXTENSION CORDS			
	25 ft.	50 ft.	100 ft.	150 ft.
3.2A	18 gauge	16 gauge	16 gauge	14 gauge

1. Examine extension cord before use. Make sure your extension cord is properly wired and in good condition. Always replace a damaged extension cord or have it repaired by a qualified person before using it.

2. Do not abuse extension cord. Do not pull on cord to disconnect from receptacle; always disconnect by pulling on plug. Disconnect the extension cord from the receptacle before disconnecting the product from the extension cord. Protect your extension cords from sharp objects, excessive heat and damp/wet areas.

3. Use a separate electrical circuit for your tool. This circuit must not be less than a 12-gauge wire and should be protected with a 15A time-delayed fuse. Before connecting the motor to the power line, make sure the switch is in the OFF position and the electric current is rated the same as the current stamped on the motor nameplate. Running at a lower voltage will damage the motor.

KNOW YOUR DRILL PRESS

TOOL PURPOSE

Drill presses are mainly used to drill clean, precise cylindrical holes into workpieces or enlarge existing holes. You may also find other uses for your drill press such as reaming, countersinking, counterboring, tapping, etc. Refer to the following diagrams to become familiarized with all the parts and controls of your drill press. The components will be referred to later in the manual for assembly and operation instructions.

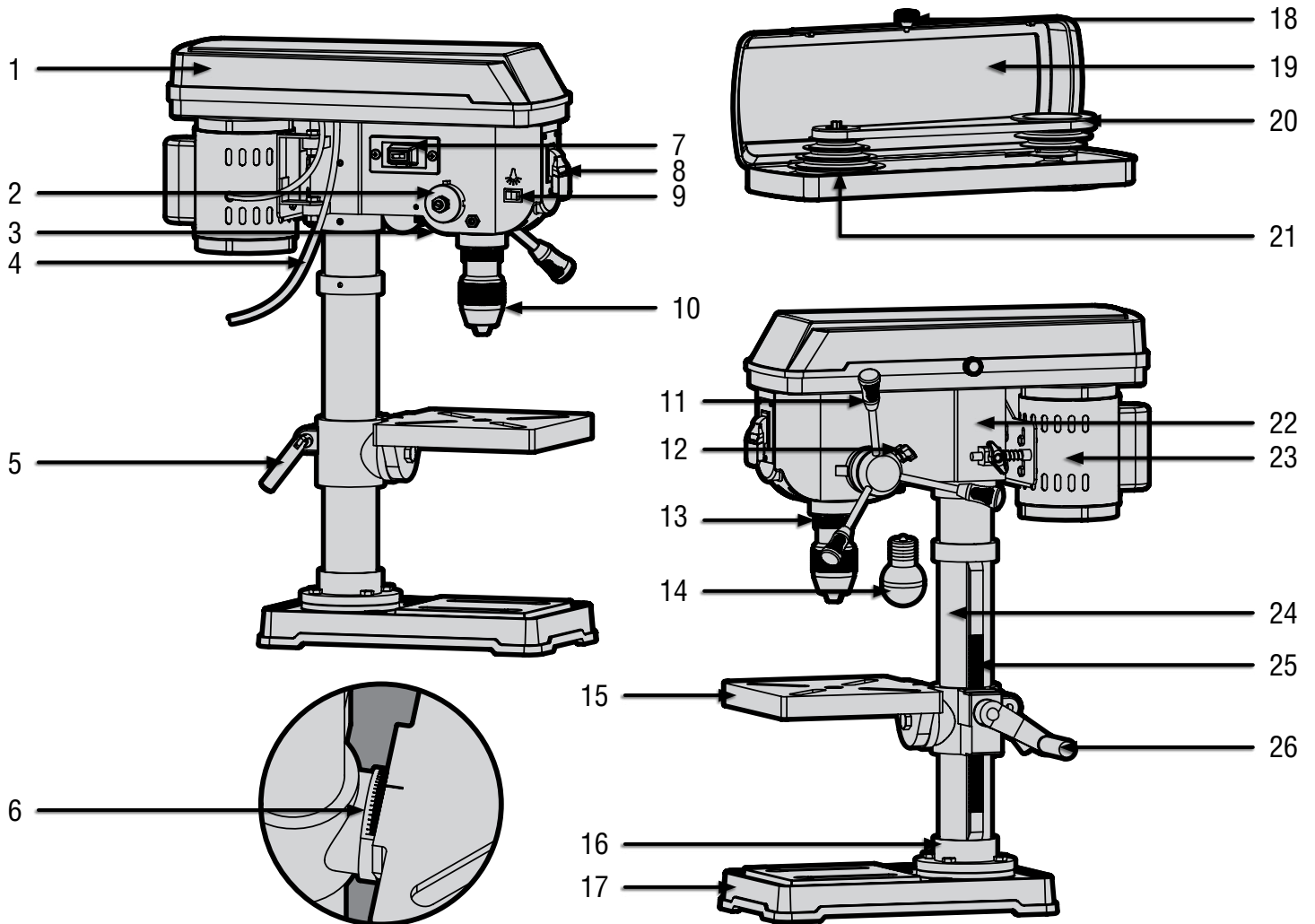

- | | |
|---------------------------|-----------------------------|
| 1. Housing Cover | 14. Worklight |
| 2. Spindle Return Spring | 15. Table |
| 3. Laser Light | 16. Column Mount |
| 4. Power Cord | 17. Base |
| 5. Table Lock | 18. Housing Knob |
| 6. Table Bevel Guide | 19. Speed Chart |
| 7. Laser Power Switch | 20. Drive (Motor) Pulley |
| 8. Power Switch | 21. Front (Spindle) Pulley |
| 9. Worklight Power Switch | 22. Drill Press Head |
| 10. Chuck | 23. Motor |
| 11. Feed Handle | 24. Column |
| 12. Depth Adjustment Lock | 25. Rack |
| 13. Spindle | 26. Table Adjustment Handle |

UNPACKING & PACKING LIST

UNPACKING

With the help of a friend or trustworthy foe, carefully remove the drill press from the packaging. Make sure to take out all contents and accessories. Do not discard the packaging until the drill press is completely assembled.

Before using the drill press, you must assemble the unit using the instructions in this section. Check your packing list against the diagram below. If any part is damaged or missing, please contact our customer service at **1-(800) 232-1195**, M-F 8-5 CST or email us at techsupport@wenproducts.com.

CLEANING THE WORK TABLE SURFACE

Your drill press comes protected with a layer of anti-rust coating on its exposed (non-painted) metal surfaces. Clean the rust-protected surfaces using a soft cloth, moistened with kerosene. Do not use gasoline, or cellulose-based solvents such as paint thinner or lacquer thinner, as these will damage the painted surfaces. After cleaning, apply a light coat of good-quality paste wax to the table and column to prevent rust. Wipe all parts thoroughly with a clean, dry cloth.

PACKING LIST

Check your packing list against the diagram below. If any part is damaged or missing, please contact our customer service at **1-(800) 232-1195**, M-F 8-5 CST or email us at techsupport@wenproducts.com and **DO NOT** plug the drill press in or turn ON.

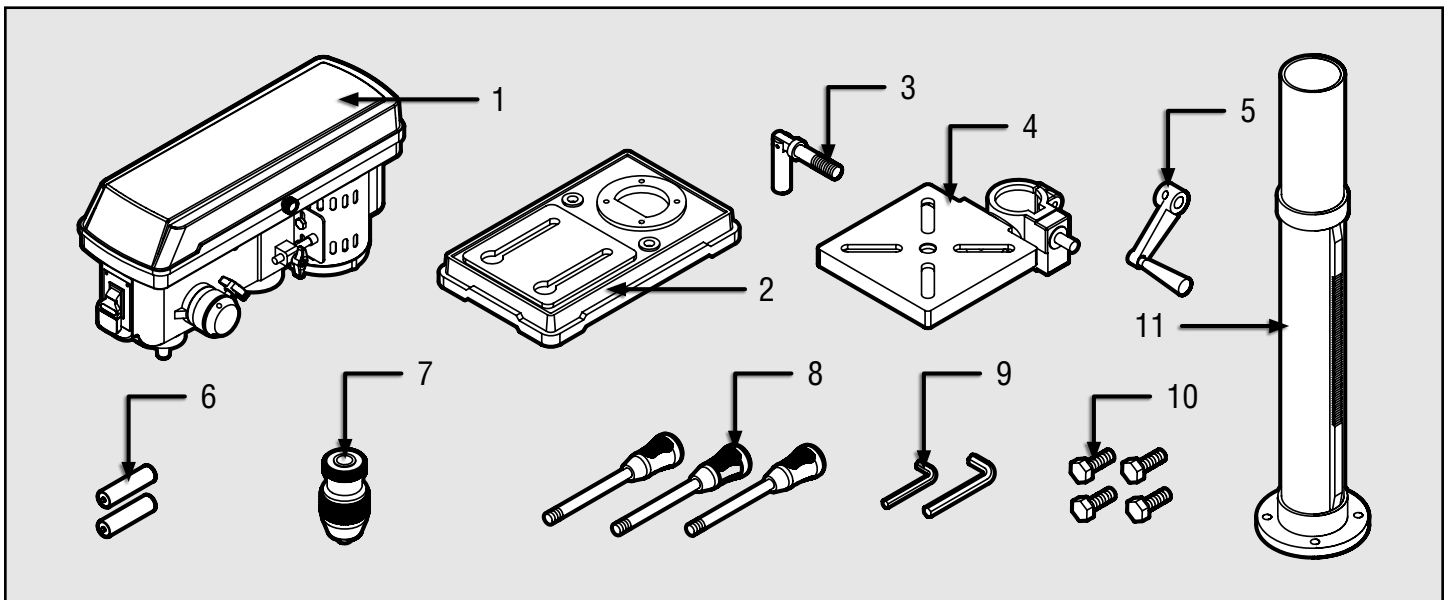

- 1. Head / Motor Assembly
- 2. Base
- 3. Table Locking Handle
- 4. Table Assembly

- 5. Table Adjustment Handle
- 6. AAA Batteries (2) (Inside Head)
- 7. Chuck
- 8. Feed Handles (3)

- 9. Hex Wrenches (2)
- 10. Hex Head Bolts (4)
- 11. Column Assembly

ASSEMBLY & ADJUSTMENTS

⚠ WARNING! Do not plug in or turn on the tool until it is fully assembled according on the instructions. Failure to follow the safety instructions may result in serious personal injury.

ATTACHING COLUMN ASSEMBLY TO BASE

1. Place the column tube on the base, aligning the column support holes to the base holes (Fig. 2).
2. Install a hex head bolt in each column support hole and tighten bolts using the adjustable wrench (not included).

ATTACHING TABLE TO COLUMN

1. Loosen set screw (Fig. 3 - 1) in rack collar and remove the collar from the column.
2. Remove the rack (Fig. 3 - 3) from the column.
3. Placing the rack into the table bracket, slide the table assembly with rack down directly onto the column (Fig. 3). The longer edge of the rack without gear teeth should be towards the top of the drill press.
4. Place the column collar down onto the rack and tighten the set screw with the smaller hex wrench to hold the rack in position.
5. Insert the table adjustment handle (Fig. 4 - 1) onto the adjustment shaft (Fig. 4 - 2). Align the socket-head set screw (Fig. 4 - 3) on the handle with the flat of the adjustment shaft. Using the larger hex wrench, tighten the set screw.
6. Position the table directly over the base, and tighten the table locking handle (Fig. 5 - 1) to secure table assembly.

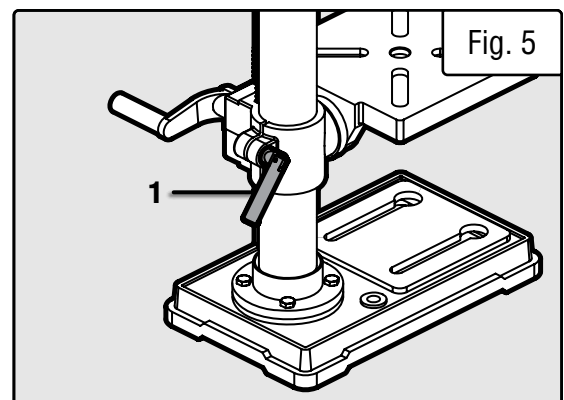
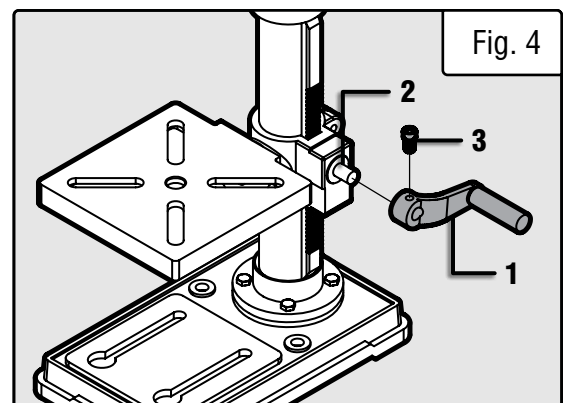
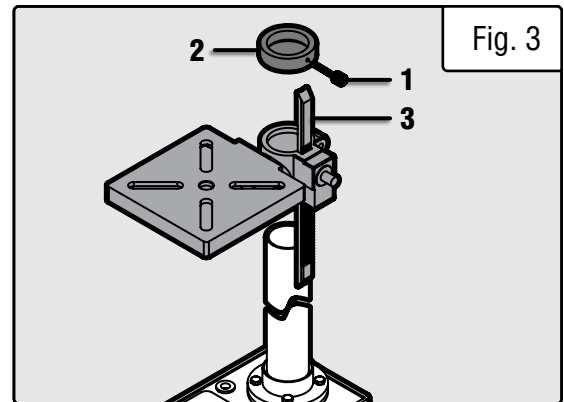
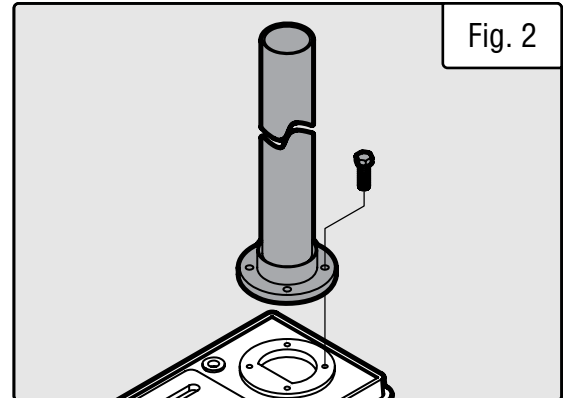

ASSEMBLY & ADJUSTMENTS

DRILL PRESS HEAD TO COLUMN

⚠ CAUTION! The drill press head is heavy. To avoid injury, two people should lift it into position.

1. Carefully lift the drill press head assembly and position it over the column (Fig. 6).
2. Place the mounting opening on the drill press head over the top of the column. Make sure the drill press head is seated properly on the column.
3. Align the direction of the drill press head with the direction of the base and the table.
4. Tighten the set screw using a hex wrench (Fig. 7).

MOUNTING THE DRILL PRESS

The drill press must be securely fastened through the mounting holes to a stand or workbench with heavy-duty fasteners (fasteners and mounting hardware not included) (Fig. 8). This will prevent the drill press from tipping over, sliding, or walking during operation.

IMPORTANT: If the stand or workbench has a tendency to move during operation, fasten the workbench securely to the floor.

INSTALLING THE CHUCK

⚠ CAUTION! Before any assembly of the chuck to the drill press spindle, clean all mating surfaces with a non-petroleum based product; such as acetone or lacquer thinner. Any oil or grease used in the packing of these parts must be removed; otherwise the chuck may come loose during operation.

1. Unplug your drill press before you begin installing the chuck. Lower the drill press table and place a cloth on it to protect the chuck if it is dropped.
2. Wipe the chuck and spindle with a clean rag. Do not use solvents yet, these will be used when you are ready to set it into place.

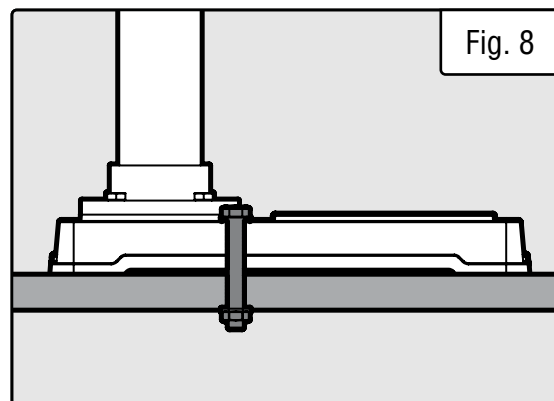
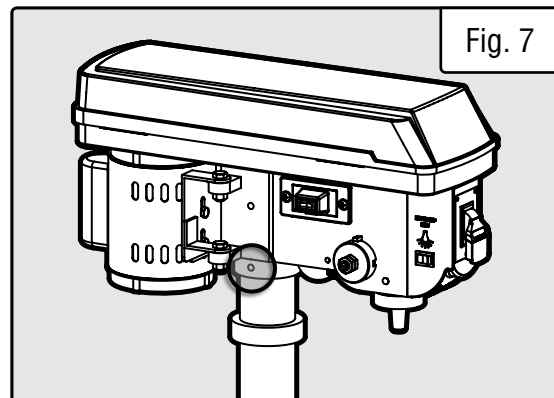
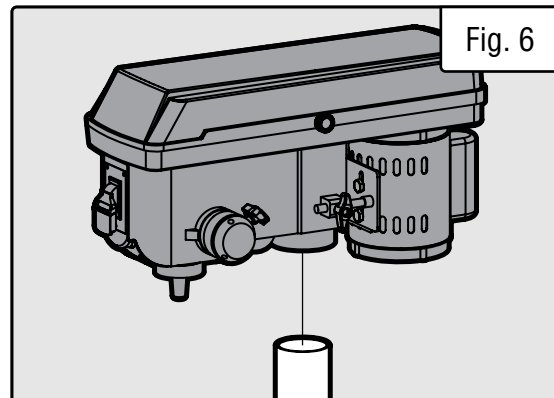

Instructions continue on the next page.

ASSEMBLY & ADJUSTMENTS

3. Completely remove any burrs found on the inner mating surface of the chuck with a diamond coated tool or a fine file. Use a grade 000 steel wool pad to lightly go over the chuck and spindle. This removes oxidation and dirt that you cannot see.

NOTE: Do steps 1-3 even if your chuck is new. New chucks can still have burrs, oxidation, and dirt.

4. Use lacquer thinner or acetone on a lint free rag to clean the chuck. Do not touch these surfaces with your hands after cleaning. Rubbing alcohol does not work well, as it contains oil. Let the chuck dry before continuing.

5. Retract the jaws of the chuck all the way into the body. Slide the chuck's socket onto the spindle. See Fig. 9.

6. Using hand force, firmly push the chuck up onto the spindle. Using a rubber mallet or dead blow hammer, tap the chuck upwards once to lock the tapers together. You can also use a piece of wood between the chuck and a standard hammer. Test the fit by gently pulling downward on the chuck. If the chuck pulls off, go back to step one and try again, making sure to thoroughly clean the mating surfaces. Your chuck is now set into your drill press and should stay in place until you need to remove it.

REMOVING THE CHUCK

NOTE: To avoid possible damage to the drill or chuck, be prepared to catch the chuck as it falls. Placing a towel on the drill press table can soften the impact if you do drop the chuck.

1. Turn the feed handles to lower the chuck to the lowest position, making it close to the table.
2. Place a ball joint separator above the chuck and tap it lightly with a hammer to cause the chuck to drop from the spindle. You should hold the chuck and be ready to catch it when it is released.

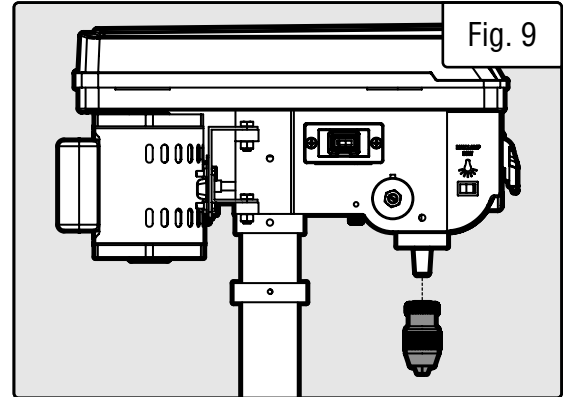

CAUTION! To avoid damaging the chuck, make sure the jaws are completely recessed into the chuck. Do not use a metal hammer to drive the chuck into the spindle.

ASSEMBLY & ADJUSTMENTS

INSTALLING LASER BATTERIES (PRE-INSTALLED)

1. Turn off the drill laser.
2. Pull the tab located below the laser switch and lift up the laser switch cover (Fig. 10).
3. Install two AAA batteries into the battery slots and close the switch cover (Fig. 11).

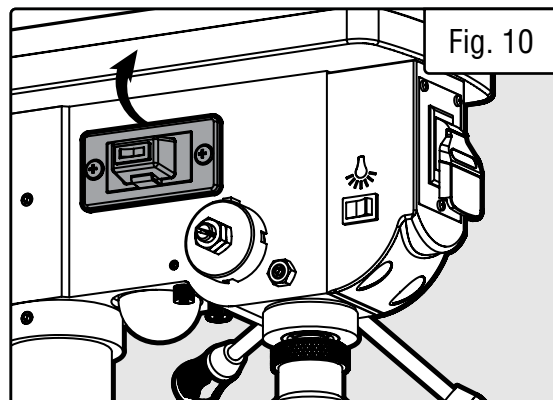

RAISING OR LOWERING THE TABLE

1. Loosen the table locking handle and turn the crank handle until the table is at the desired height (Fig. 12).
2. Tighten the table locking handle before drilling.

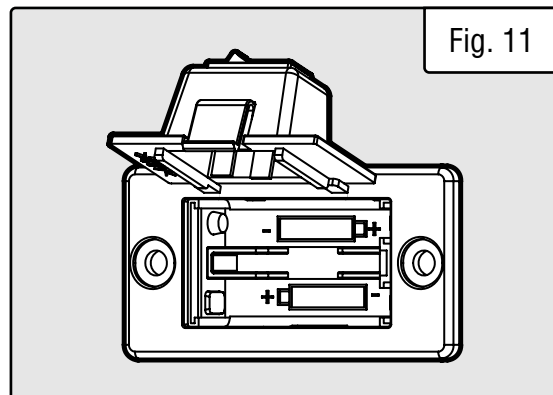

ROTATING THE TABLE

1. Loosen the table locking handle (Fig. 12 - 1) and turn the table around the column to the desired position.

NOTE: The rack should rotate around the column with the table support bracket. If the rack binds and does not rotate, slightly loosen the set screw in the rack collar.

2. Tighten the table locking handle before drilling.

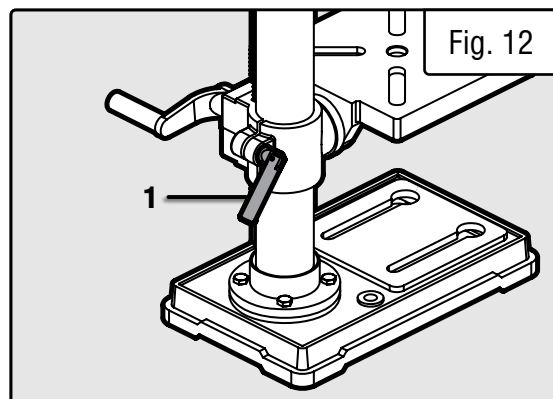

FEED HANDLES

1. Insert the three feed handles into the threaded openings on the feed hub (Fig. 13 - 1).
2. Manually tighten the handles into the openings. If desired, use an adjustable wrench (not included) to grip the flats of the feed handles and fully tighten them into the feed hub.

NOTE: When using the drill press, one or two of the feed handles may be removed if an unusually-shaped workpiece interferes with handle rotation.

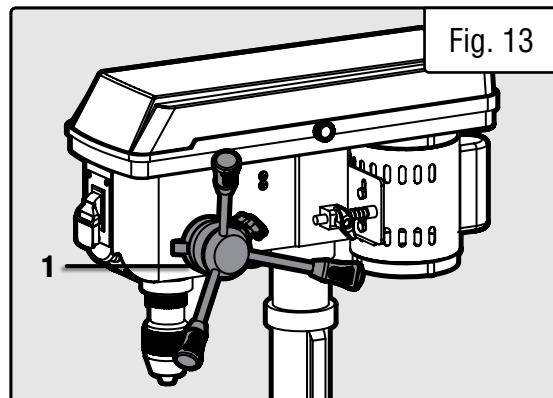

ASSEMBLY & ADJUSTMENTS

TILTING THE TABLE

1. Loosen the bevel lock bolt (Fig. 14 - 1) with a 19 mm socket or wrench (not included).
2. Tilt the table to the desired angle, using the bevel scale (Fig. 15) as a basic guide.
3. Re-tighten the bevel lock bolt.
4. To return the table to its original horizontal position, loosen the bevel lock bolt.
5. Realign the table to the 0° setting on the bevel scale.
6. Tighten the bevel lock bolt with the wrench.

INSTALLING A DRILL BIT

1. Turn the chuck (Fig. 16 - 1) counterclockwise to open the jaws (Fig. 16 - 2).
2. Insert a drill bit (Fig. 16 - 3) into the chuck so the chuck jaws grip as much of the bit's shank as possible.
3. Center the drill bit in the chuck jaws before the final tightening of the chuck.
4. Tighten the chuck jaws.

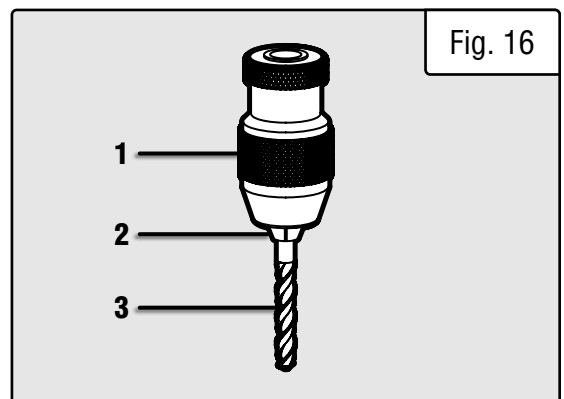
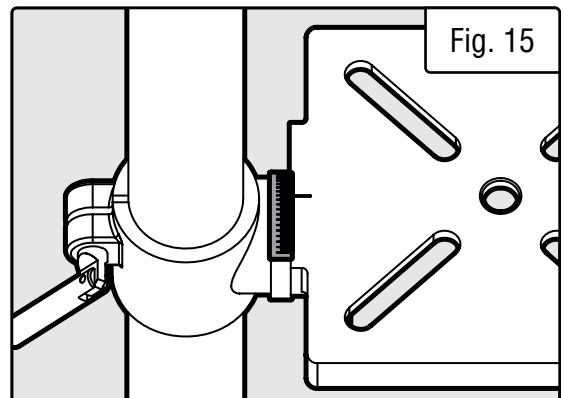
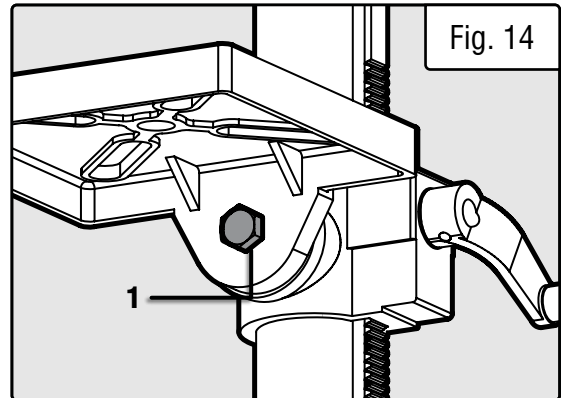

ASSEMBLY & ADJUSTMENTS

FEED DEPTH ADJUSTMENT

1. Loosen the depth locking knob (Fig. 17 - 1).
2. Turn the depth scale ring (Fig. 17 - 2) to the desired depth.
3. Lock the scale ring in place by tightening the depth locking knob.

SPEED ADJUSTMENT

1. Unplug the drill press.
2. To change to another one of the five available speeds, open the belt housing cover and loosen the belt tension locking knob (Fig. 18 - 1).
3. Pull the motor towards the front of the press and tighten the belt tension locking knob. Adjust the position of the belt on the belt pulleys.

NOTE: Ensure that the belt runs on the same setting of each pulley (e.g. if the belt is on the third setting of the motor pulley, it should be on the third setting of the spindle pulley as well).

4. Loosen the belt tension locking knob and push the motor towards the rear of the drill press, ensuring that the belt is under tension. Tighten the belt tension locking knob. Close the belt housing cover.

CHANGE THE LIGHTBULB

To change the lightbulb, turn off and unplug the machine. Turn the old bulb counter-clockwise to remove it, and screw in the new bulb. You may then plug in and restart the machine.

NOTE: Do not install a bulb rated higher than 60W. Replacement bulbs can be ordered from wenproducts.com by searching part number **4210B-086**.

ADJUST THE LASER

⚠ WARNING! Do not stare directly at the laser beam. Please observe all safety rules.

- Never aim the beam at a person or an object other than the workpiece.
- Do not project the laser beam into the eyes of others.
- Always make sure the laser beam is aimed at a non-reflective workpiece, as the laser beam could project into your eyes or the eyes of others.

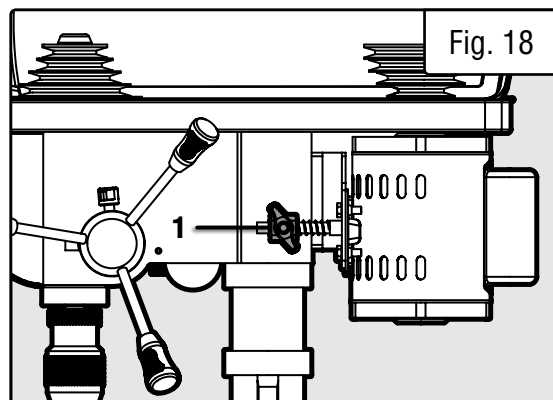
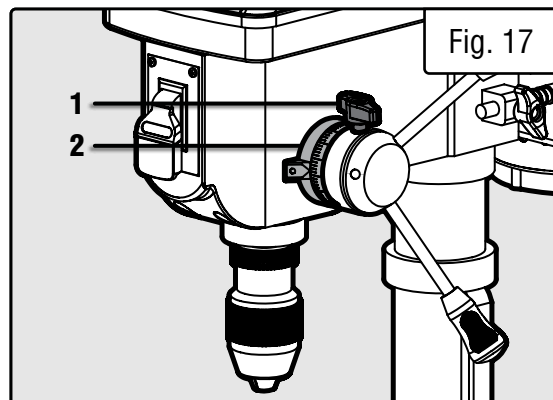

Instructions continue on the next page.

ASSEMBLY & ADJUSTMENTS

1. Unplug the drill press.
2. Place a workpiece on the table.
3. Turn the laser switch to the ON position.
4. Lower the drill bit to meet the workpiece. The two laser lines should cross where the drill meets the workpiece.

5. If the laser needs to be adjusted:

- a. Using a 3 mm hex key, turn the laser adjustment set screws (Fig. 19 - 1) counterclockwise.
 - b. Rotate the laser light housing (Fig. 19 - 2) until the two laser lines intersect where the drill meets the work piece. **DO NOT** stare directly at the laser lines.
6. Re-tighten the adjustment set screws (1). Be sure to not over tighten the set screws.

SPINDLE RETURN SPRING

The spindle is equipped with an auto-return mechanism. The main components are a spring and a notched housing. The spring was properly adjusted at the factory and should not be readjusted unless absolutely necessary.

1. Unplug the drill press.
2. Place a screwdriver into the loop (Fig. 20 - 1) to hold the spring in place.
3. Loosen the two housing nuts (Fig. 20 - 3) approximately 1/4" (6 mm). Do not remove the nuts from the threaded shaft. Do not allow the spring or spring housing to slip out of control.
4. While firmly holding the spring housing (Fig. 20 - 4), carefully pull the spring housing out until it clears the raised notch (Fig. 20 - 2).
5. Turn the housing so that the next notch is engaged with the raised notch (Fig. 20 - 2).
 - To increase the spindle return tension, turn the spring housing counter-clockwise.
 - To decrease the tension, turn the spring housing clockwise.
6. Tighten the two housing nuts. Do not overtighten the two nuts. If the nuts are tightened too much, the movement of the spindle and feed handles will become sluggish.

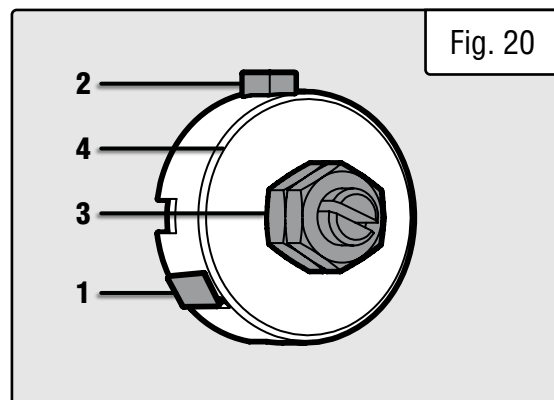
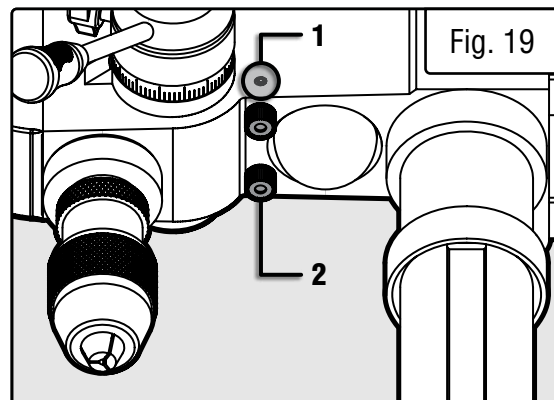

ASSEMBLY & ADJUSTMENTS

REPLACE THE BELT

⚠ WARNING! Disconnect the drill press from the power source before replacing the belt.

1. Open the housing cover. Loosen the belt tension locking knob (Fig. 21 - 1).
2. Remove the belt from the housing cover if it is broken. If it is not broken, but is too stretched to operate correctly, work the belt off the drive (motor) pulley. Then remove the belt from the front spindle.
3. Replace with a new belt. Install the belt over the pulleys at the desired speed. Pull the motor back to make the belt taut. Once the desired tension has been achieved, tighten the belt tension locking knob.

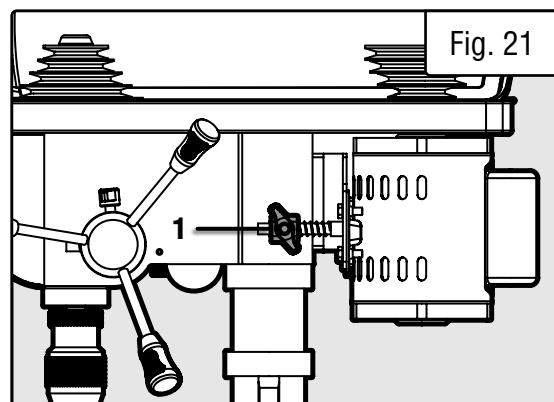

OPERATION

ON / OFF SWITCH WITH SAFETY KEY

1. To turn the drill press ON, insert the yellow safety key (Fig. 22 - 1) into the switch housing (Fig. 22 - 2). As a safety feature, the switch cannot be turned ON without the safety key.
2. Flip the switch upward to the ON position.
3. To turn the drill press OFF, flip the switch downward.
4. To lock the switch in the OFF position, remove the safety key (Fig. 22 - 1) from the switch. Store the safety key in a safe place.

⚠ WARNING! Remove the safety key whenever the drill is not in use. Place the key in a safe place and out of the reach of children.

LASER ON/OFF SWITCH

The laser switch is located on the lefthand side of the drill press (Fig. 10, p. 14). Replace batteries as needed by popping open the housing.

POSITION THE TABLE AND WORKPIECE

Always place a piece of scrap material (wood, plywood, etc.) on the table underneath the workpiece. This will prevent splintering on the underside of the workpiece as the drill bit breaks through. To keep the material from spinning out of control, it must contact the left side of the column as illustrated (Fig. 23), or be clamped (not included) to the table.

NOTE: For small workpieces that cannot be clamped to the table, use a drill press vise (not included). The vise must be clamped or bolted to the table to avoid injury. Drill press clamps and drill press vises can be purchased at wenproducts.com.

DRILLING SPEEDS

There are a few important factors to keep in mind when determining the best drilling speed:

- Material type
- Hole size
- Drill bit or cutter type
- Quality desired

Smaller drill bits require greater speed than larger drill bits. Softer materials require greater speed than harder materials.

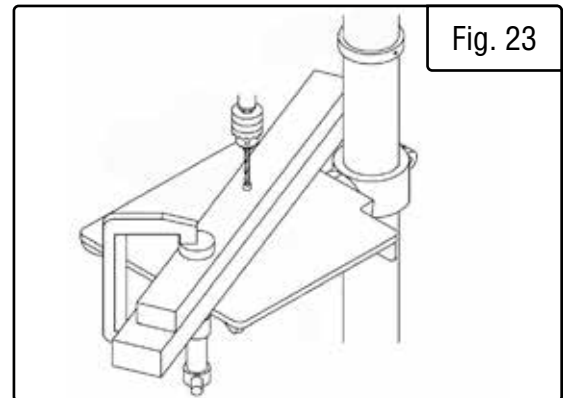
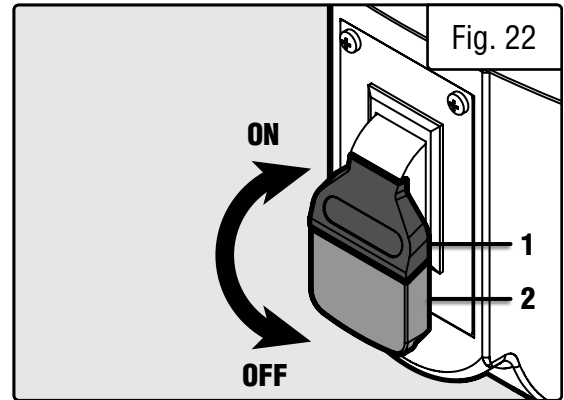

OPERATION

GENERAL DRILLING GUIDELINES - DRILLING A HOLE

⚠ WARNING! To prevent the workpiece and the backup material from slipping from your hand while drilling, position the workpiece and backup material to the left side of the column. If the workpiece and the backup material are not long enough to reach the column, clamp the workpiece and backup material to the table. Failure to do this could result in personal injury.

1. Mark where you want to drill in workpiece by using a center punch or a sharp nail, or turn ON the laser to mark your drilling point.
2. Before turning the drill press ON, turn the feed handles to bring the drill bit down. Line the drill bit tip up with the mark. Clamp the workpiece in place.
3. Turn ON the drill press and pull down on the feed handles with the appropriate force needed to allow the drill bit to drill through the material.

NOTE: Feeding too slowly might cause the drill bit to turn in the chuck. Feeding too rapidly might stop the motor, cause the belt to slip, force the workpiece loose, or break the drill bit. Practice with scrap material to get the feel of the machine before attempting to do any drilling operation.

DRILLING WOOD

- Brad point bits are preferred. Metal-piercing twist bits may be used on wood.
- Do not use auger bits. Auger bits turn so rapidly that they can lift the workpiece off of the table and whirl it around.
- Always protect the drill bit by positioning the table so that the drill bit will enter the center hole when drilling through the workpiece.
- To prevent splintering, feed the drill bit slowly right as the bit is about to cut through to the backside of the workpiece.
- To reduce splintering and protect the point of the bit, use scrap wood as a backing or a base block under the workpiece.

FEEDING THE DRILL BIT

- Pull down on the feed handles with only enough force to allow the drill bit to cut.
- Feeding too rapidly might stall the motor, cause the belt to slip, damage the workpiece, or break the drill bit.
- Feeding too slowly will cause the drill bit to heat up and burn the workpiece.

MAINTENANCE

⚠ WARNING! To avoid accidents, turn OFF and unplug the tool from the electrical outlet before cleaning, adjusting, or performing any maintenance or lubrication work.

⚠ WARNING! Any attempt to repair or replace electrical parts on this tool may be hazardous. Servicing of the tool must be performed by a qualified technician. When servicing, use only identical WEN replacement parts. Use of other parts may be hazardous or induce product failure.

ROUTINE INSPECTION

Before each use, inspect the general condition of the tool. If any of these following conditions exist, do not use until parts are replaced.

Check for:

- Loose hardware or improper mounting,
- Misalignment
- Damaged cord/electrical wiring,
- Cracked or broken parts, and
- Any other condition that may affect its safe operation

⚠ CAUTION! Most plastics are susceptible to damage from various types of commercial solvents. Do not use any solvents or cleaning products that could damage the plastic parts. Some of these include but are not limited to: gasoline, carbon tetrachloride, chlorinated cleaning solvents, and household detergents that contain ammonia.

CLEANING & STORAGE

1. After every operation, use a vacuum to remove sawdust or metal shavings from the tool surfaces, motor housing and work area. Keep the ventilation openings free from dust and debris to prevent the motor from overheating.
2. Wipe the tool surfaces clean with a soft cloth or brush. Make sure water does not get into the tool.
3. Apply a light coat of paste wax to the column and table to help keep these surfaces clean and rust free.
4. Store the tool in a clean and dry place away from the reach of children.

LUBRICATION

The ball bearings in the spindle and the V-belt pulley assembly are greased and permanently sealed, and require no lubrication. Pull the spindle down and oil the quill moderately every three months.

Lubricate the table bracket and locking knobs if they become difficult to use.

PRODUCT DISPOSAL

Used power tools should not be disposed of together with household waste. This product contains electronic components that should be recycled. Please take this product to your local recycling facility for responsible disposal and to minimize its environmental impact.

TROUBLESHOOTING GUIDE

⚠ WARNING! Stop using the tool immediately if any of the following problems occur or risk serious personal injury. If you have any questions, please contact customer service at **1-800-232-1195** (M-F 8-5 CST), or email techsupport@wenproducts.com.

PROBLEM	CAUSE	SOLUTION
Noisy Operation	<ol style="list-style-type: none"> 1) Incorrect belt tension 2) Dry spindle 3) Loose spindle pulley 4) Loose motor pulley 	<ol style="list-style-type: none"> 1) Adjust the belt tension (See REPLACE THE BELT section) 2) Lubricate the spindle 3) Tighten the set screws on the side of the spindle pulley 4) Tighten the set screws on the side of the motor pulley
The drill bit burns or smokes	<ol style="list-style-type: none"> 1) Drilling at the incorrect speed 2) The wood chips are not coming out of the hole 3) Dull drill bit 4) Feeding the workpiece too slowly 5) Not lubricated 	<ol style="list-style-type: none"> 1) Change the speed 2) Retract the drill bit frequently to clear the chips 3) Resharpen or replace the drill bit 4) Feed fast enough to cut the workpiece 5) Lubricate the drill bit with cutting oil or motor oil
Excessive drill run out or wobble; drilled hole is not round	<ol style="list-style-type: none"> 1) Bent drill bit 2) Bit improperly installed in the chuck 3) Worn spindle bearings 4) Lengths of cutting flutes or angles not appropriate for the hardness of the wood grain 5) Chuck not properly installed 	<ol style="list-style-type: none"> 1) Replace the drill bit 2) Reinstall the bit 3) Bearings may need replacement. Contact customer service (1-800-232-1195) 4) Resharpen the drill bit correctly or replace with the appropriate type 5) Reinstall the chuck

TROUBLESHOOTING GUIDE

⚠ WARNING! Stop using the tool immediately if any of the following problems occur or risk serious personal injury. If you have any questions, please contact customer service at **1-800-232-1195** (M-F 8-5 CST), or email **techsupport@wenproducts.com**.

PROBLEM	CAUSE	SOLUTION
Drill bit binds in the workpiece	<ol style="list-style-type: none"> 1) The workpiece is pinching the bit 2) Excessive feed pressure 	<ol style="list-style-type: none"> 1) Support or clamp the workpiece 2) Feed more slowly
Spindle returns too slowly or too quickly	Coil spring has improper tension	Adjust the coil spring tension (see p .17)
Chuck falls off spindle	Dirt, grease, or oil on the tapered surface on the spindle or in the chuck	Clean the tapered surface of both the chuck and spindle with a household detergent
Motor will not run	<ol style="list-style-type: none"> 1) Defective or broken switch 2) Defective or damaged power cord 3) Open circuit, loose connections, or burned out motor 4) Low voltage 	<ol style="list-style-type: none"> 1) Take to a qualified service technician 2) Take to a qualified service technician 3) Take to a qualified service technician 4) Check the power line for the proper voltage. Use another circuit or have a qualified electrician upgrade the service.
Motor stalls	<ol style="list-style-type: none"> 1) Short circuit in motor 2) Incorrect fuses or circuit breakers 3) Overloaded circuit 4) Low voltage 	<ol style="list-style-type: none"> 1) Take to a qualified service technician 2) Replace with correct fuse or circuit breaker for the circuit 3) Turn off other machines and retry 4) Check the power line for the proper voltage. Use another circuit or have a qualified electrician upgrade the service.

EXPLODED VIEW & PARTS LIST

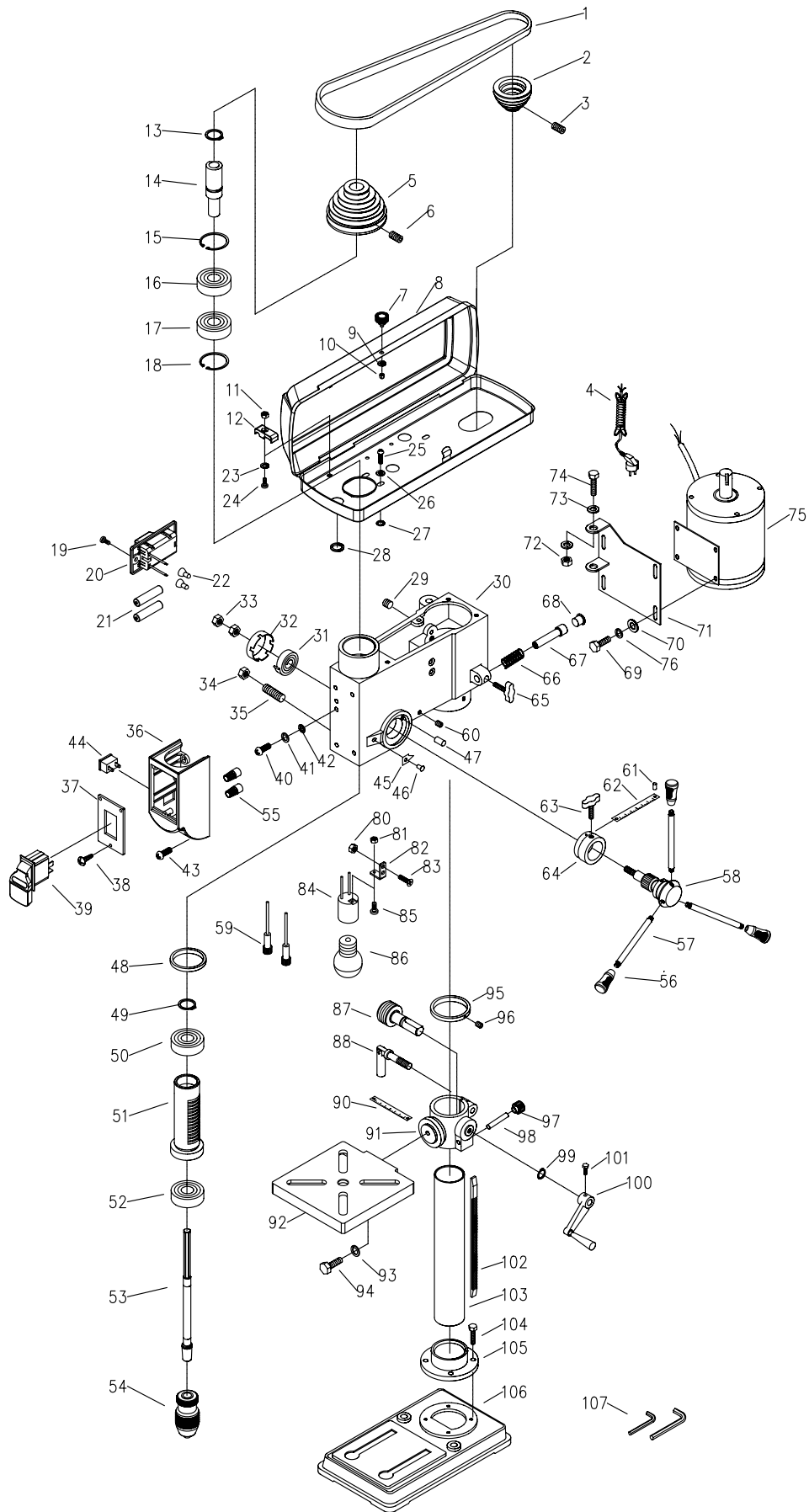

EXPLODED VIEW & PARTS LIST

No.	Part No.	Description	Qty.
1	4210B-001	V-belt	1
2	4210B-002	Motor Pulley	1
3	4210B-003	Set Screw	2
4	4210B-004	Power Cord	1
5	4210B-005	Spindle Pulley	1
6	4210B-006	Set Screw	2
7	4210B-007	Belt House Knob	1
8	4210B-008	Belt House	1
9	4210B-009	Flat Washer	1
10	4210B-010	Nut	1
11	4210B-011	Hex Nut	3
12	4210B-012	Cord Clamper	3
13	4210B-013	Retaining Ring	1
14	4210B-014	Sleeve	1
15	4210B-015	Retaining Ring	1
16	4210B-016	Ball Bearing	1
17	4210B-017	Ball Bearing	1
18	4210B-018	Retaining Ring	1
19	4210B-019	Pan Head Screw	2
20	4210B-020	Laser Battery Housing	1
21	4210B-021	AAA battery	2
22	4210B-022	Connecting terminal	2
23	4210B-023	Flat Washer	3
24	4210B-024	Pan Head Screw	3
25	4210B-025	Pan Head Screw	4
26	4210B-026	Flat Washer	4
27	4210B-027	Rubber Washer	4
28	4210B-028	Bushing	3
29	4210B-029	Set Screw	2
30	4210B-030	Head	1
31	4210B-031	Spring	1
32	4210B-032	Spring Cap	1
33	4210B-033	Hex Nut	2
34	4210B-034	Hex Nut	1
35	4210B-035	Set Screw	1
36	4210B-036	Switch Box	1
37	4210B-037	Switch Plate	1
38	4210B-038	Thread Forming Screw	3
39	4210B-039	Switch	1

No.	Part No.	Description	Qty.
40	4210B-040	Pan Head Screw	2
41	4210B-041	Lock Washer	2
42	4210B-042	Serrated Washer	2
43	4210B-043	Pan Head Screw	4
44	4210B-044	Light Switch	1
45	4210B-045	Depth Pointer	1
46	4210B-046	Rivet	1
47	4210B-047	Pin	1
48	4210B-048	Rubber Washer	1
49	4210B-049	Retaining Ring	1
50	4210B-050	Ball Bearing	1
51	4210B-051	Quill	1
52	4210B-052	Ball Bearing	1
53	4210B-053	Spindle	1
54	DPA130L	Keyless Chuck	1
55	4210B-055	Connecting Terminal	2
56	4210B-056	Knob	3
57	4210B-057	Feeding Handle	3
58	4210B-058	Gear Shaft	1
59	4210B-059	Laser	2
60	4210B-060	Set Screw	2
61	4210B-061	Rivet	2
62	4210B-062	Depth Scale	1
63	4210B-063	Wing Screw	1
64	4210B-064	Depth Stop Ring	1
65	4210B-065	Wing Screw	1
66	4210B-066	Spring	1
67	4210B-067	Pushing Shaft	1
68	4210B-068	Cap	1
69	4210B-069	Hex Head Bolt	4
70	4210B-070	Flat Washer	4
71	4210B-071	Motor Support	1
72	4210B-072	Hex Nut	2
73	4210B-073	Flat Washer	4
74	4210B-074	Hex Head Bolt	2
75	4210B-075	Motor	1
76	4210B-076	Lock Washer	4
80	4210B-080	Hex Nut	2
81	4210B-081	Hex Nut	1

EXPLODED VIEW & PARTS LIST

No.	Part No.	Description	Qty.
82	4210B-082	Support Plate	1
83	4210B-083	Flat Head Screw	2
84	4210B-084	Light Bulb Holder	1
85	4210B-085	Pan Head Screw	1
86	4210B-086	Light Bulb	1
87	4210B-087	Worm Shaft	1
88	4210B-088	Table Locking Handle	1
90	4210B-090	Angle Scale	1
91	4210B-091	Table Support	1
92	4210B-092	Table	1
93	4210B-093	Washer	1
94	4210B-094	Hex Head Bolt	1
95	4210B-095	Column Collar	1

No.	Part No.	Description	Qty.
96	4210B-096	Set Screw	1
97	4210B-097	Worm Gear	1
98	4210B-098	Pin	1
99	4210B-099	Retaining Ring	1
100	4210B-100	Table Adjusting Handle	1
101	4210B-101	Socket Head Bolt	1
102	4210B-102	Rack	1
103	4210B-103	Column	1
104	4210B-104	Hex Head Bolt	4
105	4210B-105	Column Support	1
106	4210B-106	Base	1
107	4210B-107	Wrench	2

WARRANTY STATEMENT

WEN Products is committed to building tools that are dependable for years. Our warranties are consistent with this commitment and our dedication to quality.

LIMITED WARRANTY OF WEN PRODUCTS FOR HOME USE

GREAT LAKES TECHNOLOGIES, LLC (“Seller”) warrants to the original purchaser only, that all WEN consumer power tools will be free from defects in material or workmanship during personal use for a period of two (2) years from date of purchase or 500 hours of use; whichever comes first. Ninety days for all WEN products if the tool is used for professional or commercial use. Purchaser has 30 days from the date of purchase to report missing or damaged parts.

SELLER’S SOLE OBLIGATION AND YOUR EXCLUSIVE REMEDY under this Limited Warranty and, to the extent permitted by law, any warranty or condition implied by law, shall be the replacement of parts, without charge, which are defective in material or workmanship and which have not been subjected to misuse, alteration, careless handling, misrepair, abuse, neglect, normal wear and tear, improper maintenance, improper storage, incorrect lubricants/fuels, or other conditions adversely affecting the Product or the component of the Product, whether by accident or intentionally, by persons other than Seller. To make a claim under this Limited Warranty, you must make sure to keep a copy of your proof of purchase that clearly defines the Date of Purchase (month and year) and the Place of Purchase. Place of Purchase must be a direct vendor of Great Lakes Technologies, LLC. Purchasing through third party vendors, including but not limited to garage sales, pawn shops, resale shops, or any other secondhand merchant, voids the warranty included with this product. Contact techsupport@wenproducts.com or 1-800-232-1195 with the following information to make arrangements: your shipping address, phone number, serial number, required part numbers, and proof of purchase. Damaged or defective parts and products may need to be sent to WEN before the replacements can be shipped out.

Upon the confirmation of a WEN representative, your product may qualify for repairs and service work. When returning a product for warranty service, the shipping charges must be prepaid by the purchaser. The product must be shipped in its original container (or an equivalent), properly packed to withstand the hazards of shipment. The product must be fully insured with a copy of the proof of purchase enclosed. There must also be a description of the problem in order to help our repairs department diagnose and fix the issue. Repairs will be made and the product will be returned and shipped back to the purchaser at no charge for addresses within the contiguous United States.

THIS LIMITED WARRANTY DOES NOT APPLY TO ITEMS THAT WEAR OUT FROM REGULAR USAGE OVER TIME, INCLUDING FILTERS, SPARK PLUGS, VOLTAGE REGULATORS, BRUSHES, GASKETS, O-RINGS, WHEEL KITS, BATTERIES, RECOIL STARTERS, HIGH PRESSURE HOSES, SPRAY GUNS, ETC. ANY IMPLIED WARRANTIES SHALL BE LIMITED IN DURATION TO TWO (2) YEARS FROM DATE OF PURCHASE. SOME STATES IN THE U.S. AND SOME CANADIAN PROVINCES DO NOT ALLOW LIMITATIONS ON HOW LONG AN IMPLIED WARRANTY LASTS, SO THE ABOVE LIMITATION MAY NOT APPLY TO YOU.

IN NO EVENT SHALL SELLER BE LIABLE FOR ANY INCIDENTAL OR CONSEQUENTIAL DAMAGES (INCLUDING BUT NOT LIMITED TO LIABILITY FOR LOSS OF PROFITS) ARISING FROM THE SALE OR USE OF THIS PRODUCT. SOME STATES IN THE U.S. AND SOME CANADIAN PROVINCES DO NOT ALLOW THE EXCLUSION OR LIMITATION OF INCIDENTAL OR CONSEQUENTIAL DAMAGES, SO THE ABOVE LIMITATION OR EXCLUSION MAY NOT APPLY TO YOU.

THIS LIMITED WARRANTY GIVES YOU SPECIFIC LEGAL RIGHTS, AND YOU MAY ALSO HAVE OTHER RIGHTS WHICH VARY FROM STATE TO STATE IN THE U.S., PROVINCE TO PROVINCE IN CANADA AND FROM COUNTRY TO COUNTRY.

THIS LIMITED WARRANTY APPLIES ONLY TO ITEMS SOLD WITHIN THE UNITED STATES OF AMERICA, CANADA AND THE COMMONWEALTH OF PUERTO RICO. FOR WARRANTY COVERAGE WITHIN OTHER COUNTRIES, CONTACT THE WEN CUSTOMER SUPPORT LINE. FOR WARRANTY PARTS OR PRODUCTS REPAIRED UNDER WARRANTY SHIPPING TO ADDRESSES OUTSIDE OF THE CONTIGUOUS UNITED STATES, ADDITIONAL SHIPPING CHARGES MAY APPLY.

**THANKS FOR
REMEMBERING**

