

INSTRUCTION MANUAL

PARTS

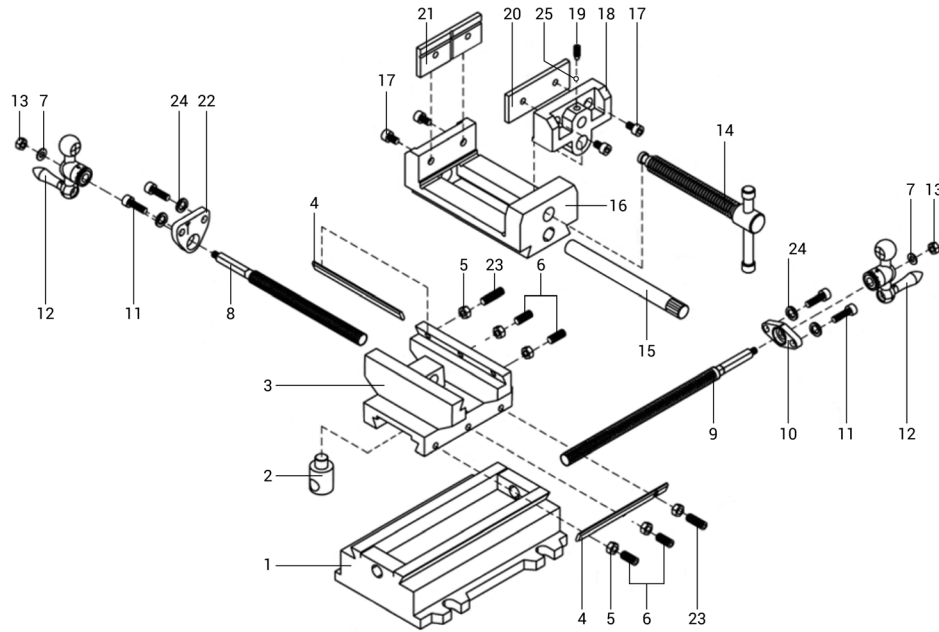

No.	Part No.	Description	Qty.
1	416CV-001	Base	1
2	416CV-002	Nut	1
3	416CV-003	Saddle	1
4	418CV-004	Gib	2
5	416CV-005	Hex Nut, M6	6
6	416CV-006	Set Screw, M6x20	4
7	413CV-007	Flat Washer, M6	2
8	418CV-008	Longitudinal Feed Screw	1
9	416CV-009	Cross Feed Screw	1
10	416CV-010	Retaining Plate	1
11	416CV-011	Socket Head Bolt, M8x20	4
12	416CV-012	Crank Handle Assembly	2

No.	Part No.	Description	Qty.
13	413CV-013	Locking Nut, M6	2
14	418CV-014	Leadscrew With Handle	1
15	418CV-015	Guide Rod	1
16	418CV-016	Body	1
17	416CV-017	Socket Head Bolt, M8x20	4
18	418CV-018	Movable Jaw	1
19	416CV-019	Dog Point Set Screw, M8x10	1
20	418CV-020	Jaw Plate	1
21	418CV-021	Grooved Jaw Plate	1
22	416CV-022	Retaining Plate	1
23	416CV-023	Set Screw, M6x25	2
24	416CV-024	Lock Washer, M6	4
25	414CV-025	Ball Bearing	1



MODEL 418CV

8-3/8-INCH CROSS VISE

ÉTAU POUR PERCEUSE

ASSEMBLY

- Remove all components and parts from the box. Your cross vise includes the following hardware:
 - (3) Hex Wrenches
 - (2) Flat Washers
 - (2) Locking Nuts
 - (2) Crank Handles
- If necessary, adjust the longitudinal (top) feed screw until the handle-mounting portion of the feed screw protrudes beyond the vise body, as shown in Fig. 1 below. Turning the feed screw clockwise retracts it; turning it counterclockwise advances it. Turn the feed screw fully clockwise until it can no longer retract.
- Mount one of the crank handles on the leadscrew, as shown in Fig. 2 below.
- Secure the crank handle to the feed screw using the included flat washer and locking nut (Fig. 2). Tighten the nut (turning clockwise) against the handle using a 10 mm socket (not included), then back it off a quarter turn (turning counterclockwise). Turn the handle a couple of times. If it is difficult to turn, loosen the nut. Adjust the nut as necessary to ensure that the handle turns smoothly and advances the slide properly.
- Repeat the same procedure to mount the remaining crank handle on the cross feed screw.

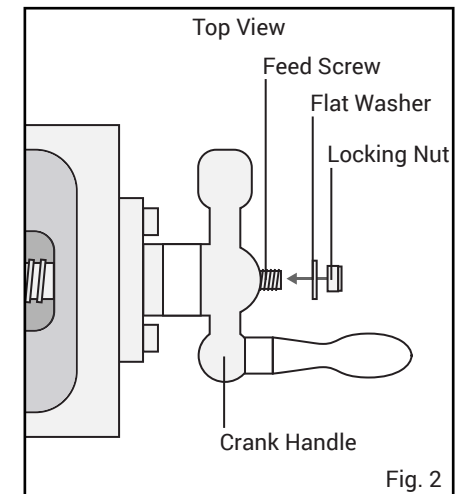
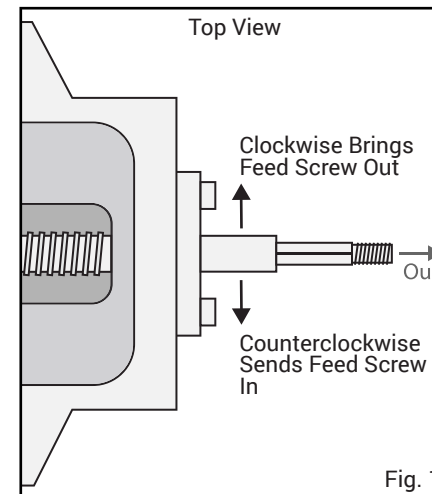

INSTRUCTION MANUAL

MAINTENANCE

⚠ Acetone may irritate the skin. Wear gloves and eye protection when using acetone.

- Your vise comes with a layer of anti-rust protective coating on the machined surfaces. Remove this coating with a clean cloth moistened with acetone, then protect the machined surfaces by applying a light coat of good-quality paste wax.
- After using your vise, wipe it off with a cloth to ensure that no chips, shavings, or other debris get into the way of your vise. Keep your vise clean. Periodically check the ways of the vise to ensure that they are not blocked or damaged by chips, shavings, or other debris.

MOUNTING INSTRUCTIONS

Follow the instructions below to safely and securely mount your cross vise to a stable workbench. Mounting your vise eliminates the risk of your vise moving or falling, allowing for more accuracy and user safety.

1. Select a secure worktop to which your vise will be mounted, such as a workbench. The workbench should be sturdy and fixed to the floor.
2. Find the best location on your worktop to mount your vise. It is good to select a spot that allows access to both crank handles, as well as the vise clamping handle (Part 14).
3. Once you have selected where you want to mount your vise, use a pencil to mark the holes where the vise will be bolted (four mounting flanges are located on the base). You must use at least two bolts that are diagonal from each other. Use four bolts for optimum stability.
4. Move the vise to the side and use a drill to drill out the marked spots for the bolts.
5. Line up the vise with the drilled holes. Insert bolts and fasten. If the bolts extend through the bench, place a washer and nut onto the end. Tighten nuts onto the bolts using a wrench. (These bolts, washers and nuts are not included).

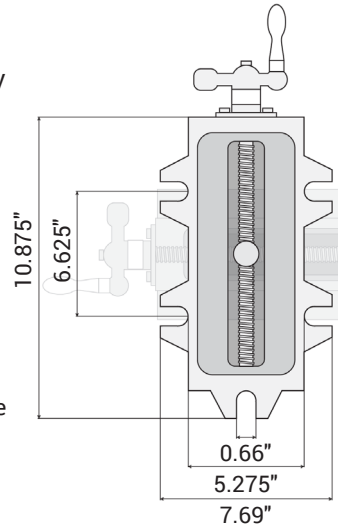

NOTE: To prevent the bolt from loosening over time, use split locking washers between flat washers, or use nylon locking nuts.

OPERATION

Before operation, mount your vise and follow the assembly instructions on page 1 to attach the handles.

1. Mark your workpiece for your specific job.
2. Rotate the leadscrew with handle counterclockwise to open the jaws. Place workpiece inside of jaws in desired position. Rotate the handle clockwise to tighten the jaws and firmly secure your workpiece.
3. To move the secured workpiece back and forth or side to side, rotate the lower and upper handles.

ADJUSTMENT GUIDE

Your vise comes pre-adjusted from the factory, and should not require adjustment. However, if the cross or longitudinal slides (Parts 1 & 16) are too tight or too loose, follow the steps below to adjust them.

1. Locate the three gib screws on the side of the slide in question (Fig. 3).
2. Loosen the three hex nuts (Part 5), using a 10 mm wrench or socket (not included). (Fig. 4 - Step 2)

3. IF THE SLIDE IS TOO TIGHT

- Loosen the set screws (Parts 6 & 23) using the included hex wrench (Fig. 4 - 3A).

IF THE SLIDE IS TOO LOOSE

- Tighten the set screws (Parts 6 & 23) using the included hex wrench (Fig. 4 - 3B).

4. Using the 10 mm wrench or socket, tighten the hex nuts (Part 5) back down. Make further adjustments as needed.

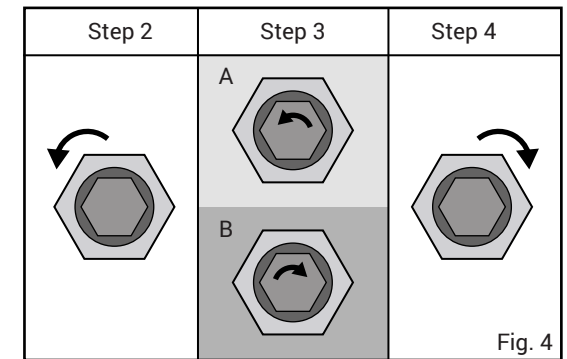
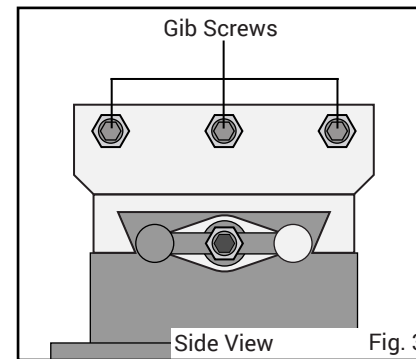

SPECIFICATIONS

Jaw Capacity	8-3/8 in.
Cross Slide Travel	9.5 in.
Longitudinal Slide Travel	8.5 in.
Clamping Strength	3000 LBF
Dimensions	20-1/4 in. x 16-3/4 in. x 7-1/4 in.
Weight	74.9 lbs

NEED HELP? CONTACT US!

Have product questions? Need technical support?
Please feel free to contact us at:

800-232-1195 (M-F 8-5 CST)

techsupport@wenproducts.com

WENPRODUCTS.COM