

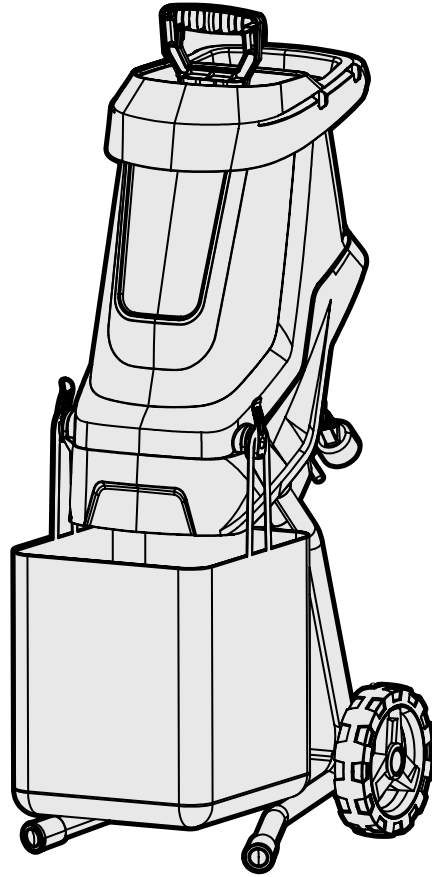

**MODEL 41119**

***PORTABLE ELECTRIC  
WOOD CHIPPER & SHREDDER***  
Instruction Manual



***NEED HELP? CONTACT US!***

Have product questions? Need technical support? Please feel free to contact us:



**1-847-429-9263 (M-F 8AM-5PM CST)**



**TECHSUPPORT@WENPRODUCTS.COM**

**IMPORTANT:** Your new tool has been engineered and manufactured to WEN's highest standards for dependability, ease of operation, and operator safety. When properly cared for, this product will supply you years of rugged, trouble-free performance. Pay close attention to the rules for safe operation, warnings, and cautions. If you use your tool properly and for its intended purpose, you will enjoy years of safe, reliable service.

For replacement parts and the most up-to-date instruction manuals, visit ***WENPRODUCTS.COM***

# CONTENTS

<b>WELCOME</b>	<b>3</b>
Introduction .....	3
Specifications.....	3
<b>SAFETY</b>	<b>4</b>
General Safety Rules.....	4
Wood Chipper & Shredder Safety Warnings .....	6
Electrical Information.....	8
<b>BEFORE OPERATING</b>	<b>9</b>
Know Your Wood Chipper & Shredder.....	9
Unpacking & Packing List.....	10
Assembly & Adjustment.....	11
<b>OPERATION &amp; MAINTENANCE</b>	<b>13</b>
Operation .....	13
Maintenance.....	14
Troubleshooting Guide.....	16
Exploded View & Parts List.....	17
Warranty Statement.....	20

To purchase accessories and replacement parts for your tool, visit ***WENPRODUCTS.COM***

## INTRODUCTION

Thanks for purchasing the WEN Wood Chipper & Shredder. We know you are excited to put your tool to work, but first, please take a moment to read through the manual. Safe operation of this tool requires that you read and understand this operator's manual and all the labels affixed to the tool. This manual provides information regarding potential safety concerns, as well as helpful assembly and operating instructions for your tool.

 Indicates danger, warning, or caution. The safety symbols and the explanations with them deserve your careful attention and understanding. Always follow the safety precautions to reduce the risk of fire, electric shock or personal injury. However, please note that these instructions and warnings are not substitutes for proper accident prevention measures.

**NOTE:** The following safety information is not meant to cover all possible conditions and situations that may occur. WEN reserves the right to change this product and specifications at any time without prior notice.

At WEN, we are continuously improving our products. If you find that your tool does not exactly match this manual, please visit [wenproducts.com](http://wenproducts.com) for the most up-to-date manual or contact our customer service at **1-847-429-9263**.

**Keep this manual available to all users during the entire life of the tool and review it frequently to maximize safety for both yourself and others.**

## SPECIFICATIONS

Model Number	41119
Motor	120V AC, 60 Hz, 15A
No Load Speed	4000 RPM
Maximum Cutting Diameter	1-3/4 in. (45mm)
Bag Capacity	12 gal (45 L)
Product Weight	19.2 lbs
Product Dimensions	17.3 in. x 14.2 in. x 37.0 in.

# GENERAL SAFETY RULES

 **WARNING!** Read all safety warnings and all instructions. Failure to follow the warnings and instructions may result in electric shock, fire and/or serious injury.

Safety is a combination of common sense, staying alert and knowing how your item works. The term “power tool” in the warnings refers to your mains-operated (corded) power tool or battery-operated (cordless) power tool.

## SAVE THESE SAFETY INSTRUCTIONS.

### WORK AREA SAFETY

- 1. Keep work area clean and well lit.** Cluttered or dark areas invite accidents.
- 2. Do not operate power tools in explosive atmospheres, such as in the presence of flammable liquids, gases or dust.** Power tools create sparks which may ignite the dust or fumes.
- 3. Keep children and bystanders away while operating a power tool.** Distractions can cause you to lose control.

### ELECTRICAL SAFETY

- 1. Power tool plugs must match the outlet. Never modify the plug in any way.** Do not use any adapter plugs with earthed (grounded) power tools. Unmodified plugs and matching outlets will reduce risk of electric shock.
- 2. Avoid body contact with earthed or grounded surfaces such as pipes, radiators, ranges and refrigerators.** There is an increased risk of electric shock if your body is earthed or grounded.
- 3. Do not expose power tools to rain or wet conditions.** Water entering a power tool will increase the risk of electric shock.
- 4. Do not abuse the cord. Never use the cord for carrying, pulling or unplugging the power tool.** Keep cord away from heat, oil, sharp edges or moving parts. Damaged or entangled cords increase the risk of electric shock.
- 5. When operating a power tool outdoors, use an extension cord suitable for outdoor use.** Use of a cord suitable for outdoor use reduces the risk of electric shock.
- 6. If operating a power tool in a damp location is unavoidable, use a ground fault circuit interrupter (GFCI) protected supply.** Use of a GFCI reduces the risk of electric shock.

### PERSONAL SAFETY

- 1. Stay alert, watch what you are doing and use common sense when operating a power tool.** Do not use a power tool while you are tired or under the influence of drugs, alcohol or medication. A moment of inattention while operating power tools may result in serious personal injury.
- 2. Use personal protective equipment. Always wear eye protection.** Protective equipment such as a respiratory mask, non-skid safety shoes and hearing protection used for appropriate conditions will reduce the risk of personal injury.
- 3. Prevent unintentional starting.** Ensure the switch is in the off-position before connecting to power source and/or battery pack, picking up or carrying the tool. Carrying power tools with your finger on the switch or energizing power tools that have the switch on invites accidents.
- 4. Remove any adjusting key or wrench before turning the power tool on.** A wrench or a key left attached to a rotating part of the power tool may result in personal injury.
- 5. Do not overreach. Keep proper footing and balance at all times.** This enables better control of the power tool in unexpected situations.
- 6. Dress properly. Do not wear loose clothing or jewelry.** Keep your hair and clothing away from moving parts. Loose clothes, jewelry or long hair can be caught in moving parts.
- 7. If devices are provided for the connection of dust extraction and collection facilities, ensure these are connected and properly used.** Use of dust collection can reduce dust-related hazards.

## GENERAL SAFETY RULES

 **WARNING!** Read all safety warnings and all instructions. Failure to follow the warnings and instructions may result in electric shock, fire and/or serious injury.

Safety is a combination of common sense, staying alert and knowing how your item works. The term “power tool” in the warnings refers to your mains-operated (corded) power tool or battery-operated (cordless) power tool.

### SAVE THESE SAFETY INSTRUCTIONS.

**8. Do not let familiarity gained from frequent use of tools allow you to become complacent and ignore tool safety principles.** A careless action can cause severe injury within a fraction of a second.

#### POWER TOOL USE AND CARE

**1. Do not force the power tool.** Use the correct power tool for your application. The correct power tool will do the job better and safer at the rate for which it was designed.

**2. Do not use the power tool if the switch does not turn it on and off.** Any power tool that cannot be controlled with the switch is dangerous and must be repaired.

**3. Disconnect the plug from the power source and/or the battery pack from the power tool before making any adjustments, changing accessories, or storing power tools.** Such preventive safety measures reduce the risk of starting the power tool accidentally.

**4. Store idle power tools out of the reach of children and do not allow persons unfamiliar with the power tool or these instructions to operate the power tool.** Power tools are dangerous in the hands of untrained users.

**5. Maintain power tools.** Check for misalignment or binding of moving parts, breakage of parts and any other condition that may affect the power tool's operation. If damaged, have the power tool repaired before use. Many accidents are caused by poorly maintained power tools.

**6. Keep cutting tools sharp and clean.** Properly maintained cutting tools with sharp cutting edges are less likely to bind and are easier to control.

**7. Use the power tool, accessories and tool bits, etc. in accordance with these instructions, taking into account the working conditions and the work to be performed.** Use of the power tool for operations different from those intended could result in a hazardous situation.

**8. Keep handles and grips dry, clean, and free from oil and grease.** Slippery handles and grasping surfaces do not allow for safe handling and control of the tool in unexpected situations.

**9. KEEP GUARDS IN PLACE** and in working order.

#### SERVICE

**1. Have your power tool serviced by a qualified repair person using only identical replacement parts.** This will ensure that the safety of the power tool is maintained.

#### CALIFORNIA PROPOSITION 65 WARNING

Some dust created by power sanding, sawing, grinding, drilling, and other construction activities may contain chemicals, including lead, known to the State of California to cause cancer, birth defects, or other reproductive harm. Wash hands after handling. Some examples of these chemicals are:

- Lead from lead-based paints.
- Crystalline silica from bricks, cement, and other masonry products.
- Arsenic and chromium from chemically treated lumber.

Your risk from these exposures varies depending on how often you do this type of work. To reduce your exposure to these chemicals, work in a well-ventilated area with approved safety equipment such as dust masks specially designed to filter out microscopic particles.

# WOOD CHIPPER & SHREDDER SAFETY WARNINGS

 **WARNING!** Do not let comfort or familiarity with the product replace strict adherence to product safety rules. Failure to follow the safety instructions may result in serious personal injury.

## WOOD CHIPPER & SHREDDER SAFETY

**1. Tool Purpose.** This shredder is designed for cutting up small branches. Shredding other materials may result in serious injuries, machine damage, and voiding of the warranty.

**2. Keep all parts of the body away from the hopper, blades, and discharge chute when operating the shredder.** Before starting the shredder, make sure that nothing is in contact with the blades.

**3. Preventing accidental startups.** Make sure the power switch is in the OFF position prior to plugging in the machine. Always make sure the power switch is in the OFF position and the machine is unplugged when doing any cleaning, adjustments, assembly, setup operations, or when the machine is not in use.

## PERSONAL SAFETY

**1. Do not use the shredder in rainy or wet locations.** Do not operate in gaseous or explosive atmospheres or near flammable or combustible liquids. The motor may spark and ignite fumes.

**2. The shredder must be used in the upright position only.** Do not operate the shredder with it lying on its side. Do not tilt the shredder while it is running.

**3. Wear ANSI Z87.1-approved safety goggles to protect your eyes.** Use hearing protection to protect yourself from hearing loss.

**4. DO NOT wear loose clothing or jewelry as they might get drawn in by the tool.** Tie back long hair. Wear rubber gloves and non-slip footwear.

**5. People with pacemakers should consult their physician(s) before use.** Electromagnetic fields in close proximity to pacemakers could cause pacemaker interference or pacemaker failure.

**6. Chips are harmful to your health.** Use NIOSH-approved dust masks or other respiratory protection during operation and cleaning.

## PREPARING THE SHREDDER

**1. Use the wheels and handle to transport the shredder.** Never carry the device by its guards or its accessories.

**2. Examine the shredder for any damaged or missing parts.** Replace or repair damaged parts before operation. Periodically check that all nuts, bolts and other fasteners are properly tightened.

**3. Do not operate this tool until it is completely assembled and installed according to the instructions.** Make sure all adjustments are correct and all connections are tight. Keep all guards in place. Make sure that the hopper inlet is empty before starting the shredder.

## DURING OPERATION

**1. Examine materials before feeding them into the shredder.** Make sure to remove pieces of metal, rocks, bottles, cans or other foreign objects. Before you shred roots, remove any remaining soil and stones from them. Do not shred soft, damp material such as kitchen waste.

**2. Feed materials slowly.** Always use the paddle supplied with your shredder to push items into the hopper. Do not force materials into the hopper. Do not feed materials larger than the recommended diameter of 1-3/4 inches, otherwise you may clog the shredder and damage the machine.

**3. Keep clear of moving parts and openings.** Keep arms, hands, and other vital appendages away from the hopper, blades, and discharge chute. Never put your hands into the hopper while the shredder is running. Always stand clear of the discharge zone when operating the shredder. Never reach under the hopper until the shredder has come to a complete stop and has been disconnected from the power supply. Never attempt to cut anything with the grinding wheel.

**4. Do not use the shredder unless all guards are in place.** Do not operate with any guard disabled, damaged, or removed. Moving guards must move freely and close instantly.

# WOOD CHIPPER & SHREDDER SAFETY WARNINGS

**⚠ WARNING!** Do not let comfort or familiarity with the product replace strict adherence to product safety rules. Failure to follow the safety instructions may result in serious personal injury.

## PREPARING THE SHREDDER (CONT.)

**5. Regularly turn off the machine and clear processed material from the discharge zone.** Buildup near the discharge zone may prevent proper discharge and can result in kickback of material through the hopper.

**6. Turn off the shredder and disconnect it from the power supply before you leave the work area.** The blades will continue to rotate for a few seconds after the unit is turned off.

**7. If the cutting mechanism strikes a foreign object or if the shredder starts making any unusual noise or vibration, turn the unit off and allow it to come to a complete stop.** Disconnect from the power supply and inspect the unit for damage. Check for any loose parts and tighten them as necessary.

**8. Should any component of your shredder be missing/damaged or fail in any way, shut off the switch and remove the plug from power supply outlet.** Have a certified technician replace the missing, damaged, or failed parts using only identical replacement parts before resuming operation.

**9. If the shredder becomes clogged, turn off the shredder and disconnect it from power supply.** Wait for the blades to come to a complete stop before clearing debris.

**10. Maintain the shredder with care.** Keep the cutting edges sharp and clean to ensure optimal performance and reduce the risk of injury.



Read and fully understand the user manual before beginning operation.



Use personal protective equipment. Always wear eye protection. Further protective equipment for hearing, head, hands, legs, and feet is recommended. Adequate protective equipment will reduce personal injury from flying debris or accidental contact with the blades.

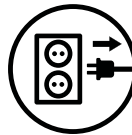

Always make sure the power switch is in the OFF position and the machine is unplugged when doing any cleaning, adjustments, assembly, setup operations, or when the machine is not in use.



DO NOT use the shredder in wet or damp conditions.



Keep all parts of the body away from the hopper, blades, and discharge chute when operating the shredder.



Always stand clear of the discharge zone when operating the shredder. Be cautious of bystanders.

**These safety instructions can't possibly warn of every scenario that may arise with this tool, always make sure to stay alert and use common sense during operation.**



## ELECTRICAL INFORMATION

### DOUBLE-INSULATED TOOLS

The tool's electrical system is double-insulated where two systems of insulation are provided. This eliminates the need for the usual three-wire grounded power cord. Double-insulated tools do not need to be grounded, nor should a means for grounding be added to the product. All exposed metal parts are isolated from the internal metal motor components with protecting insulation.



**IMPORTANT:** Servicing a double-insulated product requires extreme care and knowledge of the system, and should be done only by qualified service personnel using identical replacement parts. Always use original factory replacement parts when servicing.

**1. Polarized Plugs.** To reduce the risk of electric shock, this equipment has a polarized plug (one blade is wider than the other). This plug will fit in a polarized outlet only one way. If the plug does not fit fully in the outlet, reverse the plug. If it still does not fit, contact a qualified electrician to install a proper outlet. Do not modify the machine plug or the extension cord in any way.

**2. Ground fault circuit interrupter protection (GFCI)** should be provided on the circuit or outlet used for this power tool to reduce the risk of electric shock.

**3. Service and repair.** To avoid danger, electrical appliances must only be repaired by a qualified service technician using original replacement parts.

### GUIDELINES AND RECOMMENDATIONS FOR EXTENSION CORDS

When using an extension cord, be sure to use one heavy enough to carry the current your product will draw. An undersized cord will cause a drop in line voltage, resulting in loss of power and overheating. The table below shows the correct size to be used according to cord length and ampere rating. When in doubt, use a heavier cord. The smaller the gauge number, the heavier the cord.

AMPERAGE	REQUIRED GAUGE FOR EXTENSION CORDS			
	25 ft.	50 ft.	100 ft.	150 ft.
15A	14 Gauge	12 Gauge	Not Recommended	

**1. Examine extension cord before use.** Make sure your extension cord is properly wired and in good condition. Always replace a damaged extension cord or have it repaired by a qualified person before using it.

**2. Do not abuse extension cord.** Do not pull on cord to disconnect from receptacle; always disconnect by pulling on plug. Disconnect the extension cord from the receptacle before disconnecting the product from the extension cord. Protect your extension cords from sharp objects, excessive heat and damp/wet areas.

**3. Use a separate electrical circuit for your tool.** This circuit must not be less than a 12-gauge wire and should be protected with a 15A time-delayed fuse. Before connecting the motor to the power line, make sure the switch is in the OFF position and the electric current is rated the same as the current stamped on the motor nameplate. Running at a lower voltage will damage the motor.



# KNOW YOUR WOOD CHIPPER & SHREDDER

## TOOL PURPOSE

Your shredder is designed to cut up small branches and yard waste. Refer to the following diagrams to become familiarized with all the parts and controls of your shredder. The components will be referred to later in the manual for assembly and operation instructions.

Paddle

Handle

Hopper

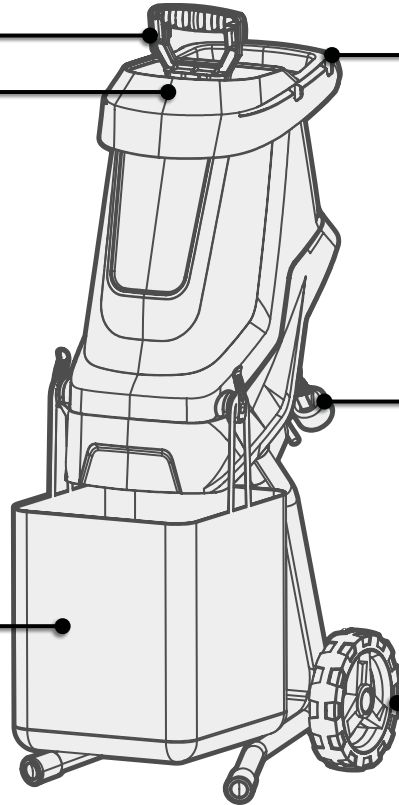

Power Cord

Collection Bag

Wheels

Feeding Chute

Wrench Storage

Hopper Lock Knob

Collection Bag Hooks

Power Switch

Cable Clip

Leg Brackets

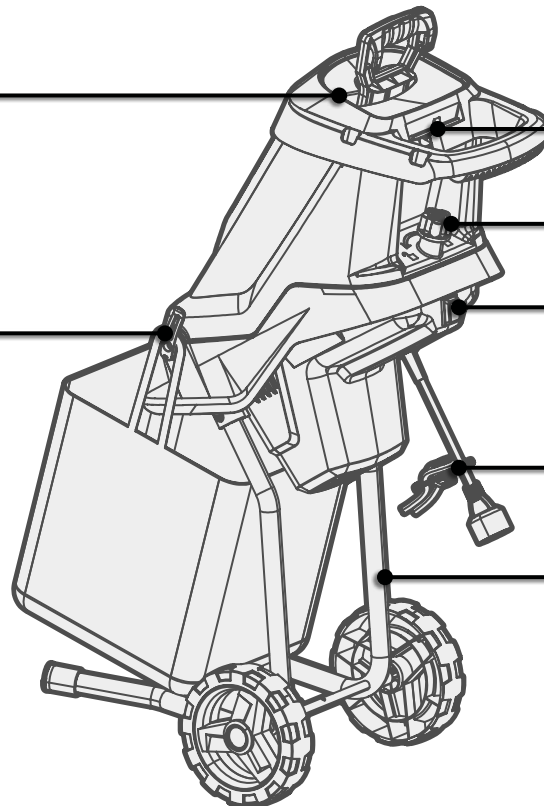

# UNPACKING & PACKING LIST

**⚠ WARNING!** Do not plug in or turn on the tool until it is fully assembled according to the instructions. Failure to follow the safety instructions may result in serious personal injury.

## UNPACKING

With the help of a friend or trustworthy foe, carefully remove the shredder from the packaging. Make sure to take out all contents and accessories. Do not discard the packaging until everything is removed. Check the packing list below to make sure you have all of the parts and accessories. If any part is missing or broken, please contact our customer service at **1-847-429-9263** (M-F 8-5 CST), or email **techsupport@wenproducts.com**.

## PACKING LIST

### Components

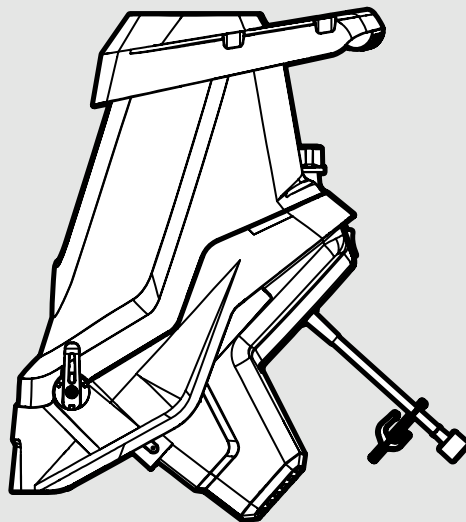

Shredder (1)

### Tools & Accessories

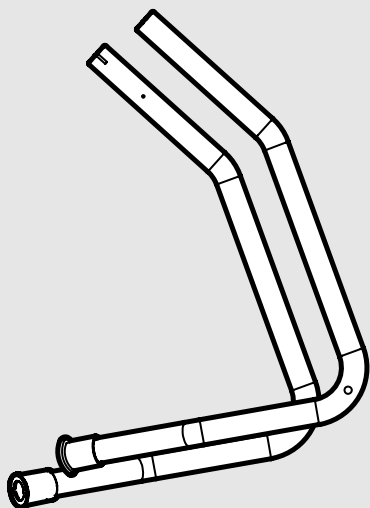

Left & Right Leg Brackets (2)

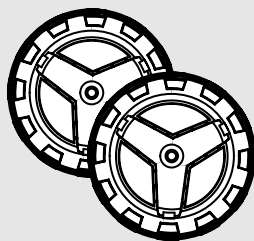

Wheels (2)

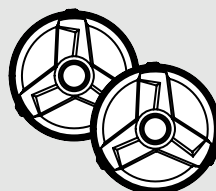

Wheel Covers (2)

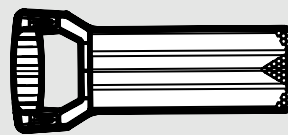

Paddle (1)



Hex Wrench (1)

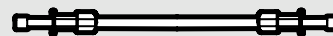

Wheel Axle & Mounting Hardware (1)

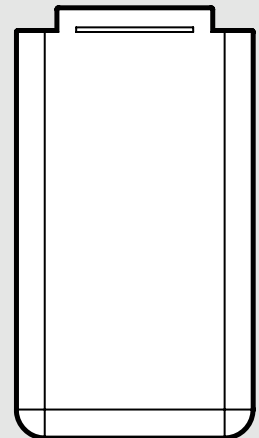

Collection Bag (1)

## ASSEMBLY & ADJUSTMENTS

**⚠ WARNING!** Do not plug in or turn on the tool until it is fully assembled according to the instructions. Failure to follow the safety instructions may result in serious personal injury.

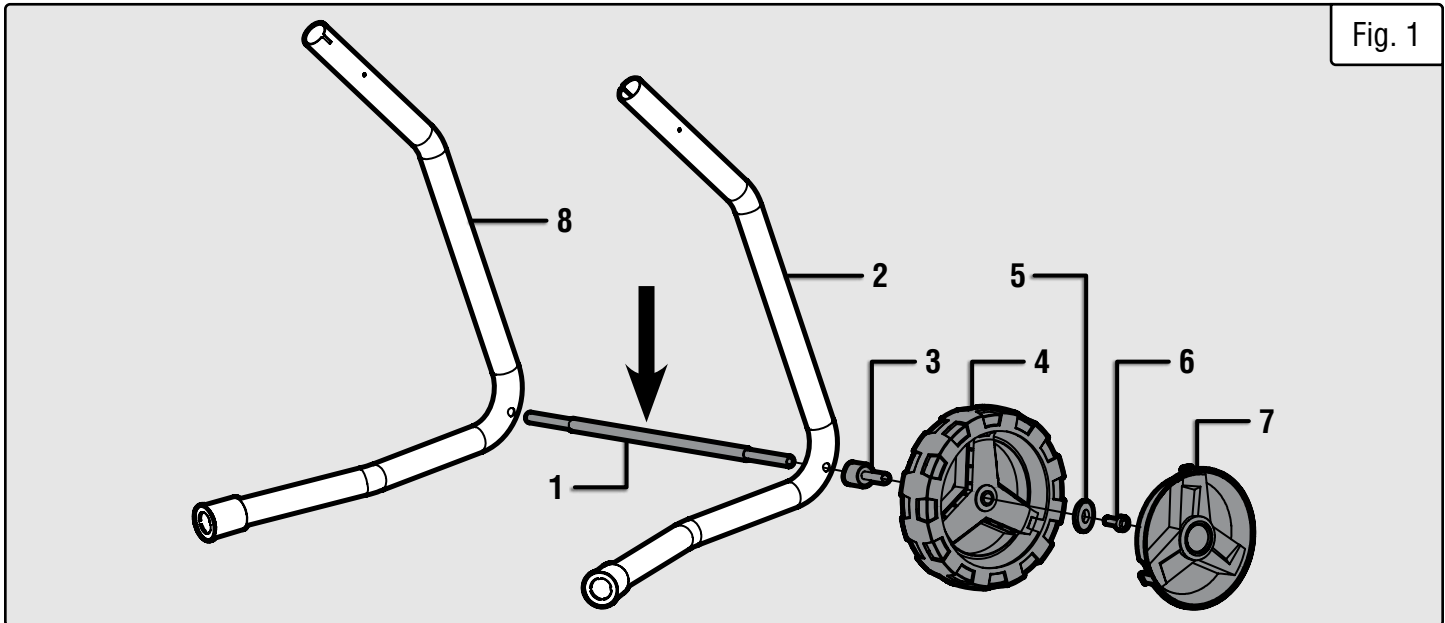

### INSTALLING THE WHEELS

1. Remove the wheel mounting hardware from the wheel axle using the included hex wrench. The wheel mounting hardware includes two hex nuts, two flat washers, and two bushings.
2. Slide the wheel axle (Fig. 1 - 1) into the hole on the side of the left leg bracket (Fig. 1 - 2) as shown in Fig. 1.
3. Place the bushing (Fig. 1 - 3) onto the axle with the curvature facing the wheel bracket as shown in Fig. 1.
4. Place the wheel (Fig. 1 - 4) onto the axle and bushing.
5. Secure the wheel onto the axle using one washer (Fig. 1 - 5) and one hex nut (Fig. 1 - 6). The included hex wrench can be used to tighten the hardware. To stop the axle from turning while tightening the hardware, fit a screwdriver (not included) into the hole in the middle of the axle (Fig. 1 - Arrow).
6. Snap the wheel cover (Fig. 1 - 7) into place on the wheel to cover the end of the wheel axle. It is okay if there is some clearance between the wheel and the wheel cover.
7. Repeat steps 2 - 6 for the right leg bracket (Fig. 1 - 8) and wheel.

## ASSEMBLY & ADJUSTMENTS

**⚠ WARNING!** Do not plug in or turn on the tool until it is fully assembled according to the instructions. Failure to follow the safety instructions may result in serious personal injury.

### INSTALLING THE LEG BRACKETS

1. Once you have the wheels properly installed on the leg brackets, flip the shredder over to install the leg bracket assembly onto the housing.
2. Remove the two screws (Fig. 2 - 1) from the bracket mounting holes on the shredder housing using a screwdriver (not included).
3. Fit the left and right leg brackets into the mounting holes. Secure them to the housing using the two screws. The wheels should be on the same side as the handle.

### INSTALLING THE ACCESSORIES

1. Hook the loops on the collection bag to the collection bag hooks (Fig. 3 - 1) on the shredder as shown in Fig. 3.
2. Use the hook and loop straps on the sides of the collection bag to secure it to the leg brackets.
3. Hang the paddle (Fig. 4 - 1) on either side of the hopper (Fig. 4 - Arrows). Use the wrench storage (Fig. 4 - 2) to store the included hex wrench for any future adjustments.

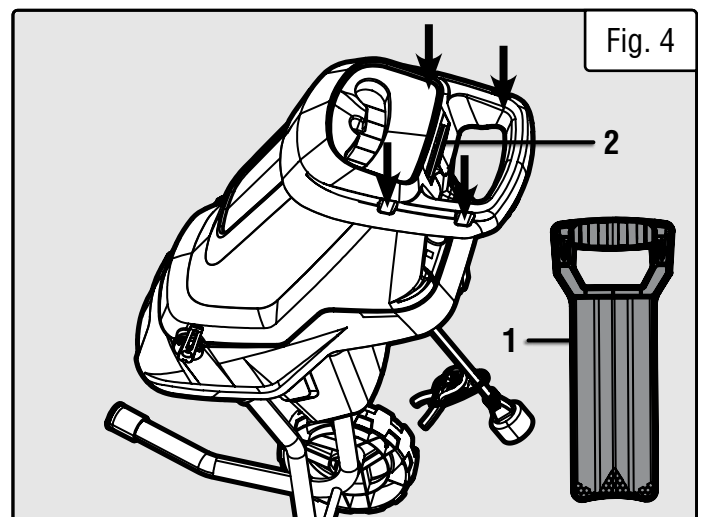
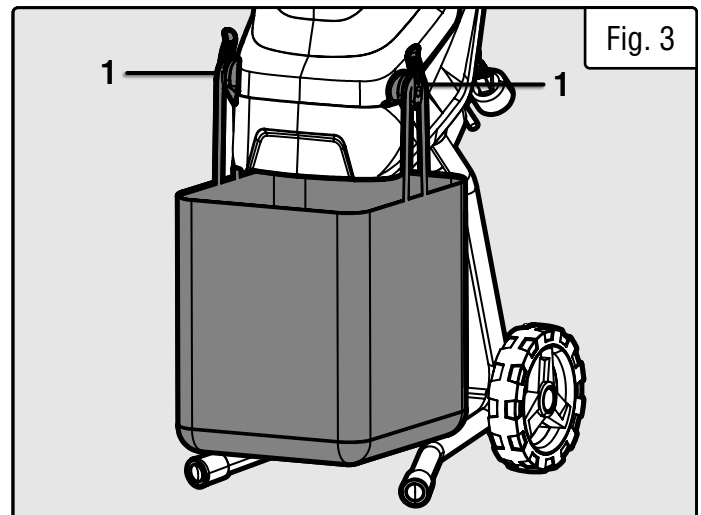
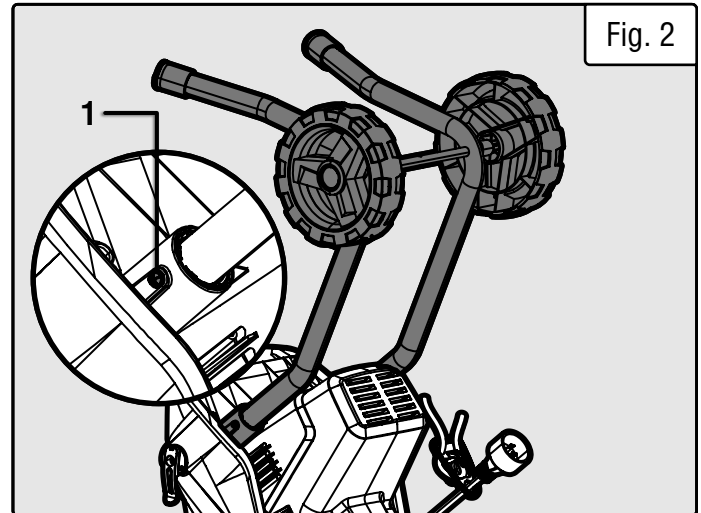

## OPERATION

### STARTING & STOPPING THE SHREDDER

1. Press the power switch (Fig. 5 - 1) to the ON position to start the motor. Let the motor run for a couple of seconds before starting to shred.
2. Turn the power switch to the OFF position to stop the motor. The shredder will stop within 5 seconds of switching it off. Unplug the shredder from the power source when it is not being operated.

### OVERLOAD PROTECTION

**⚠ WARNING!** The overload protection will activate in the following circumstances:

- A build up of debris around the cutting plate.
- The material being shredded is greater than the motor capacity.
- There is too much resistance against the cutting blade.

**⚠ WARNING!** Wear protective gloves when handling blades.

1. If the overload protection has been activated, switch the shredder OFF and unplug it from the power supply.
2. Unscrew the hopper lock knob (Fig. 5 - 2) to open the housing of the shredder.
3. Carefully remove any debris from the cutting area.
4. Close the shredder housing and lock the hopper lock knob.

### FEEDING MATERIAL

- Only insert as much material as needed to prevent blockage of the feeding chute.
- Feed wilted and damp materials alternately with dry branches to prevent cutting blades from blocking up.
- Branches with leaves must be completely processed before new material is fed. Make sure that the chopped material can fall freely from the discharge chute.
- Maintain the working speed of the shredder and do not overload it.
- Keep a few dry branches to be shredded at the end, as they will help clean your shredder.

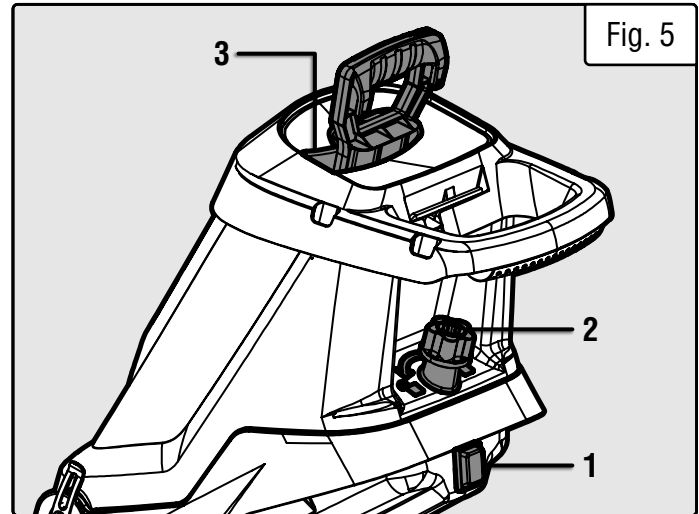

### USING THE PADDLE

Use the included paddle to help feed less bulky material such as small twigs, leaves, and other garden waste into the feeding chute.

1. Load the material into the feeding chute (Fig. 5 - 3).
2. Insert the paddle into the feeding chute and push the material into the blade plate.
3. Wait for all the material to be shredded before adding more material.

Inappropriate materials may damage the machine and cutting blades. Examine all materials before feeding them into the shredder:

- Remove pieces of metal, rocks or other foreign objects that may damage the blades.
- Do not feed wooden sticks with a diameter larger than 1-3/4 inch (45mm).
- Before shredding roots, remove any remaining soil and stones.
- Do not shred damp material such as kitchen waste.
- Do not feed the chipper after midnight. No, its not a gremlin, but it might cause your neighbors some concern.

**⚠ WARNING!** Never stick your hands into the feeding chute.

## MAINTENANCE

**⚠ WARNING!** To avoid accidents, turn OFF and unplug the tool from the electrical outlet before cleaning, adjusting, or performing any maintenance work.

### REPLACING THE BLADES

1. Make sure that the shredder is switched OFF and unplugged from the power supply before performing any maintenance.
2. Unscrew the hopper lock knob to open the housing of the shredder.

**⚠ WARNING!** Wear protective gloves when handling blades.

3. To stop the blade plate (Fig. 6 - 1) from spinning while changing the blades, fit a screwdriver (not included) into the access hole (Fig. 6 - 2). Carefully rotate the blade plate until one of the two holes in the blade plate aligns with the access hole. Fit the screwdriver into the hole to lock the blade plate in place.
4. Use the included hex wrench to remove the two blade screws (Fig. 6 - 3) from the blade.
5. The blades have two cutting edges. When one edge of the blade becomes worn, it can be flipped to use the second cutting edge.
6. Repeat steps 4 - 5 for the other blade. Once both of the cutting edges of the blades have become worn, the blades must be replaced as a pair.
7. Reinstall the blade screws, carefully remove the screwdriver, close the shredder housing, and lock the hopper lock knob.

### ROUTINE INSPECTION

Before each use, inspect the general condition of the tool. If any of these following conditions exist, do not use until parts are replaced or the tool is properly repaired.

#### Check for:

- Loose hardware
- Misalignment or binding of moving parts
- Damaged cord/electrical wiring
- Cracked or broken parts
- Any other condition that may affect its safe operation



Please recycle the packaging and electronic components where facilities exist.

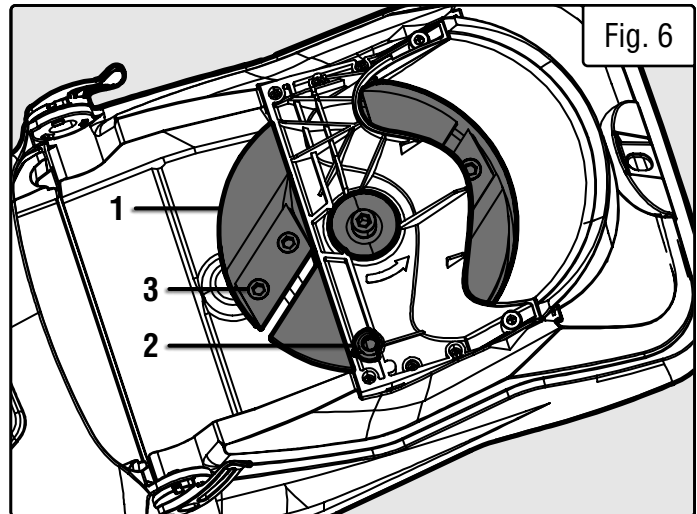

### CLEANING & STORAGE

1. Keep the ventilation openings free from dust and debris to prevent the motor from overheating.
2. Use a vacuum or low-pressure compressed air to remove dust and debris from the tool surfaces, motor housing and work area.
3. Wipe the tool surfaces clean with a soft cloth or brush. Make sure water does not get into the tool.

To clean the inside of the unit, unlock the hopper lock knob and open the shredder housing. Clean the cutting blades and the discharge area. Remove debris that may clog the blades. Check the blades for damage and replace if they show signs of wear. Close the housing and lock the hopper lock knob.

Store the tool in a clean and dry place away from the reach of children. Store in temperatures between 41° to 86°F.

Cover the tool in order to protect it from dust and moisture. It is preferable to store it in its original packaging with the instruction manual and all accessories.

### PRODUCT DISPOSAL

Used power tools should not be disposed of together with household waste. This product contains electronic components that should be recycled. Please take this product to your local recycling facility for responsible disposal and to minimize its environmental impact.



## MAINTENANCE

**⚠ WARNING!** To avoid accidents, turn OFF and unplug the tool from the electrical outlet before cleaning, adjusting, or performing any maintenance work.

### CARBON BRUSH REPLACEMENT

The wear on the carbon brushes depends on how frequently and how heavily the tool is used. To maintain maximum efficiency of the motor, we recommend inspecting the two carbon brushes every 60 hours of operation or when the tool stops working.

1. Turn OFF and unplug the machine. Wait for the blades to come to a complete stop.
2. The two carbon brushes can be accessed through the bottom of the shredder body.
3. Unscrew the six small screws on the bottom of the shredder housing (Fig. 7).
4. Remove the legs from the mounting holes on the shredder housing.
5. Separate the two housing pieces, this may require some force.
6. Once open, find the motor and carbon brush holder (Fig. 8).
7. To remove the Brush holder, press down on the front clip with either a finger nail or flat screwdriver while simultaneously pulling out the holder. Once removed, the carbon brush will pop out on its own. Install the new set of carbon brushes if either carbon brush length is worn down to  $\frac{3}{16}$ " or less.
8. Reinstall the old carbon brushes (in their original orientation) if your brushes are not worn down to  $\frac{3}{16}$ " or less. Both carbon brushes should be replaced at the same time.
9. Replace the carbon brush holder, and then repeat the steps to replace the carbon brush located on the other side of the motor.

**NOTE:** New carbon brushes tend to spark for a few minutes during the first use as they wear down.

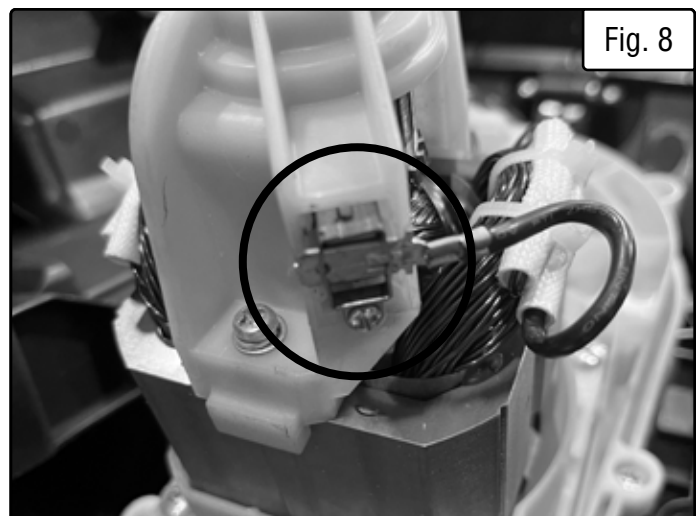
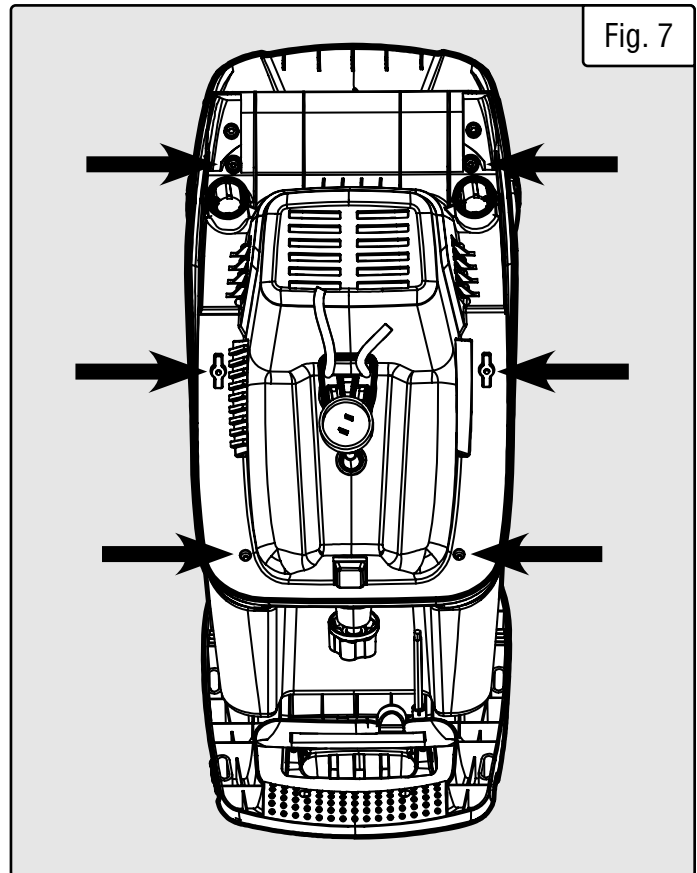



## **TROUBLESHOOTING GUIDE**

**⚠ WARNING!** Stop using the tool immediately if any of the following problems occur. Repairs and replacements should only be performed by an authorized technician. For any questions, please contact our customer service at **1-847-429-9263**, M-F 8-5 CST or email us at **techsupport@wenproducts.com**.

<b>PROBLEM</b>	<b>POSSIBLE CAUSE</b>	<b>SOLUTION</b>
<b>The motor does not start.</b>	1. The power cord or extension cord is damaged or not properly plugged in.	1. Check the power cord, extension cord, power plug, and the power outlet. Make sure the tool is properly plugged in. Do not use the tool if any cord is damaged.
	2. The motor has overloaded.	The material may be too much or too hard for the shredder to handle. Wait for motor to cool down, reduce the material load, and restart the shredder.
	3. The housing is open.	3. Check that the housing is closed and the hopper lock knob is tightened.
	4. There's a ghost in your shredder	4. Persuade the ghost to leave.
<b>Material cannot be fed into the shredder.</b>	1. The material is jammed in the feed inlet.	1. Turn OFF and unplug the machine. Open the housing and carefully remove blocked or jammed materials.
	2. The cutting blades are blocked.	2. Turn OFF and unplug the machine. Open the housing and carefully remove blocked or jammed materials.
	3. The discharge chute is blocked.	3. Turn OFF and unplug the machine. Open the housing and the plate of the discharge chute to clear the blocked material. Replace the plate and housing.
<b>Inefficient cutting.</b>	1. The cutting blade edges are worn.	1. Flip the blades or replace them with new blades.

# EXPLODED VIEW & PARTS LIST

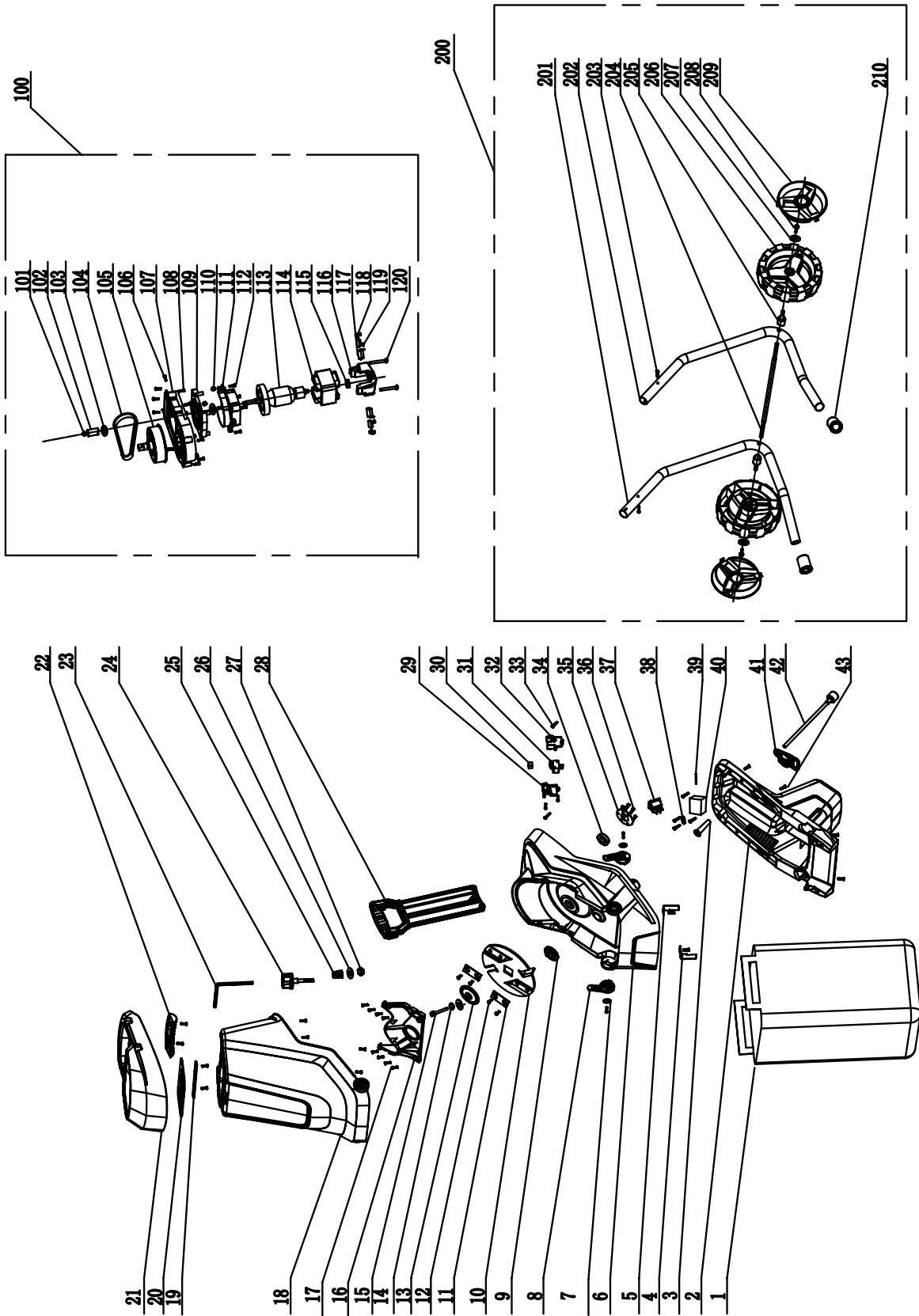

**NOTE:** Not all parts may be available for purchase. Parts and accessories that wear down over the course of normal use are not covered under the warranty.

## **EXPLODED VIEW & PARTS LIST**

No.	Part No.	Description	Qty.
1	41119-001	Collection Bag	1
2	41119-002	Lower Housing Cover	1
3	41119-003	Cord Sheath	1
4	41119-004	Wind Deflector A	1
5	41119-005	Wind Deflector B	1
6	41119-006	Lower Housing	1
7	41119-007	Washer $\phi$ 4	2
8	41119-008	Collection Bag Fixing Point	2
9	41119-009	Blade Plate Base	1
10	41119-010	Blade Plate	1
11	41119-011	Blade	2
12	41119-012	Hexagonal Countersunk Head Screw M10x12	4
13	41119-013	Blade Plate Pressure Plate	1
14	41119-014	Spring Pad $\phi$ 8	1
15	41119-015	Hex Socket Screw M8x30 (with Spacer)	1
16	41119-016	Aluminum Blade Defend Block	1
17	41119-017	Cross Recessed Pan Head Tapping Screw ST5x30	8
18	41119-018	Upper housing	1
19	41119-019	Dust-Proof Strip Clamp Plate	1
20	41119-020	Dust-Proof Strip	1
21	41119-021	Up Housing Cover	1
22	41119-022	Handle Cover	1
23	41119-023	S6xS5 Allen Key	1
24	41119-024	Knob	1
25	41119-025	Spring	1
26	41119-026	Washer $\phi$ 8	2
27	41119-027	Lock Nut M8	1
28	41119-028	Paddle	1
29	41119-029	Right Switch Box	1
30	41119-030	Fixup Nut M8x9.5	1

No.	Part No.	Description	Qty.
31	41119-031	Switch	1
32	41119-032	Left Switch Box	1
33	41119-033	Cross Slot Flange Screw ST4x16	7
34	41119-034	Single Row Radial Ball Bearings 6003 2RS	1
35	41119-035	Bearing Clamp	1
36	41119-036	Cross Recessed Pan Head Tapping Screw ST4.8x14	5
37	41119-037	Power Switch	1
38	41119-038	Cord Clamp Plate	1
39	41119-039	Internal Wiring	1
40	41119-040	PCB Board	1
41	41119-041	Cable Strain Relief	1
42	41119-042	Power Cord	1
43	41119-043	Cross Recessed Pan Head Tapping Screw ST4x20	19
100	41119-100	Motor Assembly	1
101	41119-101	Lock Nut M8	1
102	41119-102	Small Pulley	1
103	41119-103	Red Steel Paper Gasket	2
104	41119-104	Belt	1
105	41119-105	Large Pulley	1
106	41119-106	Cylindrical Head Hex Head Screw M6x16	2
107	41119-107	Center Bearing Bracket	1
108	41119-108	Cross Slot Flange ST5x16	8
109	41119-109	Motor Windscreen	1
110	41119-110	Outer Hexagon Nut M6	2
111	41119-111	Motor Front Cover	1
112	41119-112	Cross Recessed Pan Head Tapping Screw ST5x30	9
113	41119-113	Rotor Assembly	1

## **EXPLODED VIEW & PARTS LIST**

No.	Part No.	Description	Qty.
114	41119-114	Stator Assembly	1
115	41119-115	Single Row Radial Ball Bearings 608RS	1
116	41119-116	Motor Rear End Cover	1
117	41119-117	Carbon Brush Holder	2
118	41119-118	Carbon Brush	2
119	41119-119	Cross Recessed Pan Head Tapping Screw ST3x12	2
120	41119-120	Cross Recessed Pan Head Tapping Screw ST4x82	2
200	41119-200	Wheel Assembly	

No.	Part No.	Description	Qty.
201	41119-201	Left Bracket	1
202	41119-202	Right Bracket	1
203	41119-203	Cross Recessed Pointed Head Tapping Screw ST4x16	2
204	41119-204	Axle	1
205	41119-205	Bushing	2
206	41119-206	Wheel $\phi$ 180	2
207	41119-207	Washer $\phi$ 6.5	2
208	41119-208	Cylindrical Head Hex Head Screw M6x16	2
209	41119-209	Wheel Cover $\phi$ 180	2
210	41119-210	Foot Cover	2

**NOTE:** Not all parts may be available for purchase. Parts and accessories that wear down over the course of normal use are not covered under the warranty.

# **WARRANTY STATEMENT**

WEN Products is committed to building tools that are dependable for years. Our warranties are consistent with this commitment and our dedication to quality.

## **LIMITED WARRANTY OF WEN PRODUCTS FOR HOME USE**

GREAT LAKES TECHNOLOGIES, LLC (“Seller”) warrants to the original purchaser only, that all WEN consumer power tools will be free from defects in material or workmanship during personal use for a period of two (2) years from date of purchase or 500 hours of use; whichever comes first. Ninety days for all WEN products if the tool is used for professional or commercial use. Purchaser has 30 days from the date of purchase to report missing or damaged parts.

SELLER’S SOLE OBLIGATION AND YOUR EXCLUSIVE REMEDY under this Limited Warranty and, to the extent permitted by law, any warranty or condition implied by law, shall be the replacement of parts, without charge, which are defective in material or workmanship and which have not been subjected to misuse, alteration, careless handling, misrepair, abuse, neglect, normal wear and tear, improper maintenance, or other conditions adversely affecting the Product or the component of the Product, whether by accident or intentionally, by persons other than Seller. To make a claim under this Limited Warranty, you must make sure to keep a copy of your proof of purchase that clearly defines the Date of Purchase (month and year) and the Place of Purchase. Place of Purchase must be a direct vendor of Great Lakes Technologies, LLC. Purchasing through third party vendors, including but not limited to garage sales, pawn shops, resale shops, or any other secondhand merchant, voids the warranty included with this product. Contact [tech-support@wenproducts.com](mailto:tech-support@wenproducts.com) or 1-847-429-9263 with the following information to make arrangements: your shipping address, phone number, serial number, required part numbers, and proof of purchase. Damaged or defective parts and products may need to be sent to WEN before the replacements can be shipped out.

Upon the confirmation of a WEN representative, your product may qualify for repairs and service work. When returning a product for warranty service, the shipping charges must be prepaid by the purchaser. The product must be shipped in its original container (or an equivalent), properly packed to withstand the hazards of shipment. The product must be fully insured with a copy of the proof of purchase enclosed. There must also be a description of the problem in order to help our repairs department diagnose and fix the issue. Repairs will be made and the product will be returned and shipped back to the purchaser at no charge for addresses within the contiguous United States.

THIS LIMITED WARRANTY DOES NOT APPLY TO ITEMS THAT WEAR OUT FROM REGULAR USAGE OVER TIME, INCLUDING BELTS, BRUSHES, BLADES, BATTERIES, ETC. ANY IMPLIED WARRANTIES SHALL BE LIMITED IN DURATION TO TWO (2) YEARS FROM DATE OF PURCHASE. SOME STATES IN THE U.S. AND SOME CANADIAN PROVINCES DO NOT ALLOW LIMITATIONS ON HOW LONG AN IMPLIED WARRANTY LASTS, SO THE ABOVE LIMITATION MAY NOT APPLY TO YOU.

IN NO EVENT SHALL SELLER BE LIABLE FOR ANY INCIDENTAL OR CONSEQUENTIAL DAMAGES (INCLUDING BUT NOT LIMITED TO LIABILITY FOR LOSS OF PROFITS) ARISING FROM THE SALE OR USE OF THIS PRODUCT. SOME STATES IN THE U.S. AND SOME CANADIAN PROVINCES DO NOT ALLOW THE EXCLUSION OR LIMITATION OF INCIDENTAL OR CONSEQUENTIAL DAMAGES, SO THE ABOVE LIMITATION OR EXCLUSION MAY NOT APPLY TO YOU.

THIS LIMITED WARRANTY GIVES YOU SPECIFIC LEGAL RIGHTS, AND YOU MAY ALSO HAVE OTHER RIGHTS WHICH VARY FROM STATE TO STATE IN THE U.S., PROVINCE TO PROVINCE IN CANADA AND FROM COUNTRY TO COUNTRY.

THIS LIMITED WARRANTY APPLIES ONLY TO ITEMS SOLD WITHIN THE UNITED STATES OF AMERICA, CANADA AND THE COMMONWEALTH OF PUERTO RICO. FOR WARRANTY COVERAGE WITHIN OTHER COUNTRIES, CONTACT THE WEN CUSTOMER SUPPORT LINE. FOR WARRANTY PARTS OR PRODUCTS REPAIRED UNDER WARRANTY SHIPPING TO ADDRESSES OUTSIDE OF THE CONTIGUOUS UNITED STATES, ADDITIONAL SHIPPING CHARGES MAY APPLY.