

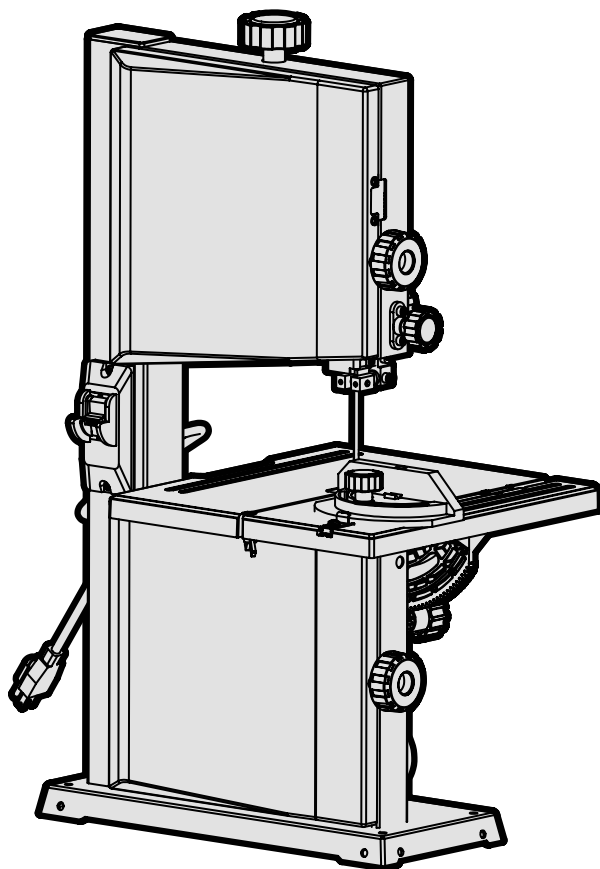

MODEL 3959, 3959T

9-INCH BAND SAW WITH FENCE & MITER GAUGE

Instruction Manual



NEED HELP? CONTACT US!

Have product questions? Need technical support? Please feel free to contact us:



1-800-232-1195 (M-F 8AM-5PM CST)



TECHSUPPORT@WENPRODUCTS.COM

IMPORTANT: Your new tool has been engineered and manufactured to WEN's highest standards for dependability, ease of operation, and operator safety. When properly cared for, this product will supply you years of rugged, trouble-free performance. Pay close attention to the rules for safe operation, warnings, and cautions. If you use your tool properly and for its intended purpose, you will enjoy years of safe, reliable service.

For replacement parts and the most up-to-date instruction manuals, visit ***WENPRODUCTS.COM***

CONTENTS

WELCOME	3
Introduction	3
Specifications.....	3
SAFETY	4
General Safety Rules	4
Circular Saw Safety Warnings.....	6
Electrical Information.....	8
Battery & Charger Safety Warnings	9
BEFORE OPERATING	11
Unpacking & Packing List.....	11
Know Your Circular Saw.....	12
Assembly & Adjustments.....	13
OPERATION & MAINTENANCE	15
Operation	15
Maintenance.....	18
Exploded View & Parts List.....	20
Warranty Statement	22

To purchase accessories and replacement parts for your tool, visit **WENPRODUCTS.COM**

INTRODUCTION

Thanks for purchasing the WEN Band Saw. We know you are excited to put your tool to work, but first, please take a moment to read through the manual. Safe operation of this tool requires that you read and understand this operator's manual and all the labels affixed to the tool. This manual provides information regarding potential safety concerns, as well as helpful assembly and operating instructions for your tool.

 Indicates danger, warning, or caution. The safety symbols and the explanations with them deserve your careful attention and understanding. Always follow the safety precautions to reduce the risk of fire, electric shock or personal injury. However, please note that these instructions and warnings are not substitutes for proper accident prevention measures.

NOTE: The following safety information is not meant to cover all possible conditions and situations that may occur. WEN reserves the right to change this product and specifications at any time without prior notice.

At WEN, we are continuously improving our products. If you find that your tool does not exactly match this manual, please visit wenproducts.com for the most up-to-date manual or contact our customer service at **1-800-232-1195**.

Keep this manual available to all users during the entire life of the tool and review it frequently to maximize safety for both yourself and others.

SPECIFICATIONS

Model Number	3959, 3959T
Motor	120V, 60 Hz, 2.5A
Blade Speed	2500 FPM
Throat	9 Inches (228 mm)
Cutting Depth	3-1/2 Inches (89 mm)
Work Table Size	12-5/16 x 11-7/8 Inches
Table Bevel Angle	0° to 45° Right
Blade Length	59-1/2 Inches (1511 mm)
Blade Width	1/8 to 3/8 Inches
Dust Port Size (Outer Diameter)	2-1/2 Inches (64 mm)
Net Weight	40 Pounds
Product Dimensions	19 in. x 14 in. x 29 in,

GENERAL SAFETY RULES

 **WARNING!** Read all safety warnings and all instructions. Failure to follow the warnings and instructions may result in electric shock, fire and/or serious injury.

Safety is a combination of common sense, staying alert and knowing how your item works. The term “power tool” in the warnings refers to your mains-operated (corded) power tool or battery-operated (cordless) power tool.

SAVE THESE SAFETY INSTRUCTIONS.

WORK AREA SAFETY

- 1. Keep work area clean and well lit.** Cluttered or dark areas invite accidents.
- 2. Do not operate power tools in explosive atmospheres, such as in the presence of flammable liquids, gases or dust.** Power tools create sparks which may ignite the dust or fumes.
- 3. Keep children and bystanders away while operating a power tool.** Distractions can cause you to lose control.

ELECTRICAL SAFETY

- 1. Power tool plugs must match the outlet. Never modify the plug in any way. Do not use any adapter plugs with earthed (grounded) power tools.** Unmodified plugs and matching outlets will reduce risk of electric shock.
- 2. Avoid body contact with earthed or grounded surfaces such as pipes, radiators, ranges and refrigerators.** There is an increased risk of electric shock if your body is earthed or grounded.
- 3. Do not expose power tools to rain or wet conditions.** Water entering a power tool will increase the risk of electric shock.
- 4. Do not abuse the cord. Never use the cord for carrying, pulling or unplugging the power tool. Keep cord away from heat, oil, sharp edges or moving parts.** Damaged or entangled cords increase the risk of electric shock.
- 5. When operating a power tool outdoors, use an extension cord suitable for outdoor use.** Use of a cord suitable for outdoor use reduces the risk of electric shock.

6. If operating a power tool in a damp location is unavoidable, use a ground fault circuit interrupter (GFCI) protected supply. Use of a GFCI reduces the risk of electric shock.

PERSONAL SAFETY

- 1. Stay alert, watch what you are doing and use common sense when operating a power tool. Do not use a power tool while you are tired or under the influence of drugs, alcohol or medication.** A moment of inattention while operating power tools may result in serious personal injury.
- 2. Use personal protective equipment. Always wear eye protection.** Protective equipment such as a respiratory mask, non-skid safety shoes and hearing protection used for appropriate conditions will reduce the risk of personal injury.
- 3. Prevent unintentional starting. Ensure the switch is in the off-position before connecting to power source and/or battery pack, picking up or carrying the tool.** Carrying power tools with your finger on the switch or energizing power tools that have the switch on invites accidents.
- 4. Remove any adjusting key or wrench before turning the power tool on.** A wrench or a key left attached to a rotating part of the power tool may result in personal injury.
- 5. Do not overreach. Keep proper footing and balance at all times.** This enables better control of the power tool in unexpected situations.
- 6. Dress properly. Do not wear loose clothing or jewelry. Keep your hair and clothing away from moving parts.** Loose clothes, jewelry or long hair can be caught in moving parts.

GENERAL SAFETY RULES

⚠ WARNING! Read all safety warnings and all instructions. Failure to follow the warnings and instructions may result in electric shock, fire and/or serious injury.

Safety is a combination of common sense, staying alert and knowing how your item works. The term “power tool” in the warnings refers to your mains-operated (corded) power tool or battery-operated (cordless) power tool.

SAVE THESE SAFETY INSTRUCTIONS.

7. If devices are provided for the connection of dust extraction and collection facilities, ensure these are connected and properly used. Use of dust collection can reduce dust-related hazards.

POWER TOOL USE AND CARE

1. Do not force the power tool. Use the correct power tool for your application. The correct power tool will do the job better and safer at the rate for which it was designed.

2. Do not use the power tool if the switch does not turn it on and off. Any power tool that cannot be controlled with the switch is dangerous and must be repaired.

3. Disconnect the plug from the power source and/or the battery pack from the power tool before making any adjustments, changing accessories, or storing power tools. Such preventive safety measures reduce the risk of starting the power tool accidentally.

4. Store idle power tools out of the reach of children and do not allow persons unfamiliar with the power tool or these instructions to operate the power tool. Power tools are dangerous in the hands of untrained users.

5. Maintain power tools. Check for misalignment or binding of moving parts, breakage of parts and any other condition that may affect the power tool's operation. If damaged, have the power tool repaired before use. Many accidents are caused by poorly maintained power tools.

6. Keep cutting tools sharp and clean. Properly maintained cutting tools with sharp cutting edges are less likely to bind and are easier to control.

7. Use the power tool, accessories and tool bits, etc. in accordance with these instructions, taking into account the working conditions and the work to be performed. Use of the power tool for operations different from those intended could result in a hazardous situation.

8. Use clamps to secure your workpiece to a stable surface. Holding a workpiece by hand or using your body to support it may lead to loss of control.

9. KEEP GUARDS IN PLACE and in working order.

SERVICE

1. Have your power tool serviced by a qualified repair person using only identical replacement parts. This will ensure that the safety of the power tool is maintained.

CALIFORNIA PROPOSITION 65 WARNING

Some dust created by power sanding, sawing, grinding, drilling, and other construction activities may contain chemicals, including lead, known to the State of California to cause cancer, birth defects, or other reproductive harm. Wash hands after handling. Some examples of these chemicals are:

- Lead from lead-based paints.
- Crystalline silica from bricks, cement, and other masonry products.
- Arsenic and chromium from chemically treated lumber.

Your risk from these exposures varies depending on how often you do this type of work. To reduce your exposure to these chemicals, work in a well-ventilated area with approved safety equipment such as dust masks specially designed to filter out microscopic particles.

SPECIFIC RULES FOR YOUR BANDSAW

 **WARNING!** Do not operate the power tool until you have read and understood the following instructions and the warning labels.

SAW BLADE SAFETY

1. Always wear protective gloves when handling saw blades.
2. Only use blades with correct size and type for both your band saw and your workpiece.
3. Never use damaged or deformed saw blades. Only use sharp blades.
4. Install the saw blade in the correct orientation indicated in the instructions.
5. Keep hands out of path of saw blade. Never use your hands to remove sawdust or scrap wood. Use a brush at all times.
6. Never reach around saw blade or reach in back of the saw blade.
7. The use of accessories or attachments not recommended by the manufacturer may result in a risk of personal injury.

PERSONAL SAFETY

1. Operate in a well ventilated area. Keep the floor area around the band saw level and free of slippery substances or other tripping hazards.
2. Wear ANSI-approved safety goggles to protect your eyes from saw dust. Use hearing protection to protect yourself from hearing loss.
3. People with pacemakers should consult their physician(s) before use. Electromagnetic fields in close proximity to pacemakers could cause pacemaker interference or pacemaker failure.
4. Wear work gloves when handling saw blades. **DO NOT** wear gloves, neckties, jewelry, or loose clothing while operating the saw.
5. Saw dust is harmful to your health. Use NIOSH-approved dust masks or other respiratory protection during operation and cleaning.
6. Always turn off and unplug the band saw before making any adjustments or repair tasks. Never adjust the band saw or the workpiece while the saw is running.
7. Only use the band saw to cut wood.

PREPARING THE BAND SAW

1. When transporting the band saw, use the transportation handle and roll the assembled saw with the wheels. Never carry the device by its guards or its accessories.
2. Examine the band saw for any damaged or missing parts. Replace or repair damaged parts before operation. Periodically check that all nuts, bolts and other fasteners are properly tightened.

SECURE YOUR WORKPIECE

1. To avoid blade binding or loss of control, always secure the workpiece to a stable platform, ensuring that body exposure is minimized. Use clamps to secure the workpiece. Never perform any operation freehand.
2. Ensure that work is correctly supported. Supports must be placed under the workpiece on both sides, close to the line of cut and near the edge of the workpiece.
3. For accuracy of cut, and to avoid blade binding, always use a rip fence or straight edge guide.
4. Never hand-hold a workpiece that is too small to be clamped, as it can be launched away and cause injury. Use proper support and guides to secure the small workpiece.
5. Use extra caution with very large, very small, or awkwardly-shaped workpieces. Small pieces should be secured with clamps. Do not hold small pieces with your hand because your fingers might go under the blade guard.
6. Support round work properly (use a V block or press it against the miter gauge) to prevent it from rolling and the blade from biting.
7. Plan intricate or small work carefully to avoid pinching the blade. Avoid awkward operations and hand positions to prevent accidental contact with the blade.

SPECIFIC RULES FOR YOUR BANDSAW

 **WARNING!** Do not operate the power tool until you have read and understood the following instructions and the warning labels.

DURING CUTTING OPERATIONS

1. Always stand to one side when operating the saw. Never have any part of the body in line with the path of the saw. Never hold a workpiece in your hand or across your legs while cutting.
2. Ensure hands are away from the cutting area and blade. Keep one hand on the rear handle, and the other on the front grip. If both hands are holding the tool they cannot be cut by the blade.
3. Feed work into the blade against the direction of rotation of the blade only.
4. If you are interrupted when operating the saw, complete the process and switch the saw off before looking up.
5. Power tools must always be held by the insulated gripping surfaces when performing an operation, ensuring protection if the cutting tool makes contact with its own cord or hidden wiring. Contact with a 'live' wire will make exposed metal parts of the power tool 'live' and shock the operator if the insulated gripping surfaces are not used.
6. Do not use the band saw unless all guards are in place. Do not operate with any guard disabled, damaged, or removed. Moving guards must move freely and close instantly.
7. Blade guide, supports, bearings, and blade tension must be properly adjusted to avoid accidental blade contact and to minimize blade breakage. To maximize blade support, always adjust the upper blade guide and blade guard so that it barely clears the workpiece.
8. Turn on the band saw and let it reach full speed, then slowly slide the saw into the workpiece. This will help produce safer and cleaner cuts.
9. Never cut more than one piece at a time. Do not stack workpieces together. Do not attempt to cut material thicker than specified in this manual. Adjust the cutting depth to the thickness of the workpiece.
10. If a cut does not extend to the edge of the workpiece, or if the blade binds in the cut, allow the blade to come to a complete stop and lift the saw out of the workpiece.
11. Turn off tool and wait for saw blade to stop before moving workpiece or changing settings. Do not slow or stop a blade with a piece of wood or by hand. Let the blade come to rest naturally. Do not attempt to free a jammed blade while the machine is still running and connected to power.
12. Always raise the blade to be covered by the blade guard after use.

ELECTRICAL INFORMATION

GROUNDING INSTRUCTIONS

In the event of a malfunction or breakdown, grounding provides the path of least resistance for an electric current and reduces the risk of electric shock. This tool is equipped with an electric cord that has an equipment grounding conductor and a grounding plug. The plug **MUST** be plugged into a matching outlet that is properly installed and grounded in accordance with ALL local codes and ordinances.

1. Do not modify the plug provided. If it will not fit the outlet, have the proper outlet installed by a licensed electrician.

2. Improper connection of the equipment grounding conductor can result in electric shock. The conductor with the green insulation (with or without yellow stripes) is the equipment grounding conductor. If repair or replacement of the electric cord or plug is necessary, **DO NOT** connect the equipment grounding conductor to a live terminal.

3. Check with a licensed electrician or service personnel if you do not completely understand the grounding instructions or whether the tool is properly grounded.

4. Use only three-wire extension cords that have three-pronged plugs and outlets that accept the tool's plug (INSERT CR). Repair or replace a damaged or worn cord immediately.

CAUTION! In all cases, make certain the outlet in question is properly grounded. If you are not sure, have a licensed electrician check the outlet.

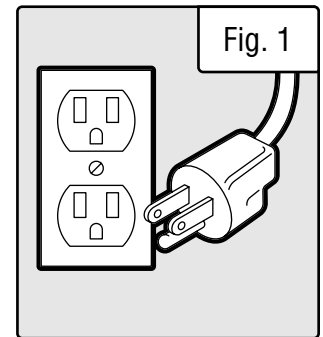

GUIDELINES AND RECOMMENDATIONS FOR EXTENSION CORDS

When using an extension cord, be sure to use one heavy enough to carry the current your product will draw. An undersized cord will cause a drop in line voltage resulting in loss of power and overheating. The table below shows the correct size to be used according to cord length and ampere rating. When in doubt, use a heavier cord. The smaller the gauge number, the heavier the cord.

AMPERAGE	REQUIRED GAUGE FOR EXTENSION CORDS			
	25 ft.	50 ft.	100 ft.	150 ft.
2.8A	18 gauge	16 gauge	16 gauge	14 gauge

1. Examine extension cord before use. Make sure your extension cord is properly wired and in good condition. Always replace a damaged extension cord or have it repaired by a qualified person before using it.

2. Do not abuse extension cord. Do not pull on cord to disconnect from receptacle; always disconnect by pulling on plug. Disconnect the extension cord from the receptacle before disconnecting the product from the extension cord. Protect your extension cords from sharp objects, excessive heat and damp/wet areas.

3. Use a separate electrical circuit for your tool. This circuit must not be less than a 12-gauge wire and should be protected with a 15A time-delayed fuse. Before connecting the motor to the power line, make sure the switch is in the OFF position and the electric current is rated the same as the current stamped on the motor nameplate. Running at a lower voltage will damage the motor.

UNPACKING & PACKING LIST

UNPACKING

With the help of a friend or trustworthy foe, such as one of your in-laws, carefully remove the band saw from the packaging and place it on a sturdy, flat surface. Make sure to take out all contents and accessories. Do not discard the packaging until everything is removed. Check the packing list below to make sure you have all of the parts and accessories. If any part is missing or broken, please contact customer service at **1-800-232-1195** (M-F 8-5 CST), or email techsupport@wenproducts.com.

Components

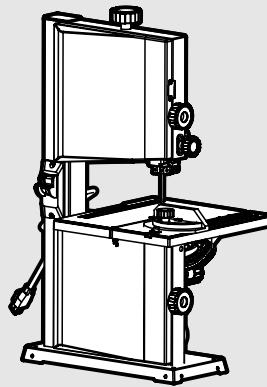

Band Saw

Accessories

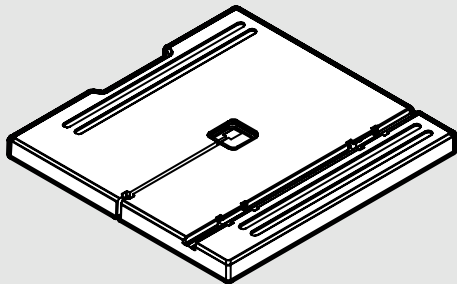

**Work Table Assembly (1)
(with Hex Bolt, Lock Washer,
Flat Washer, and Wing Nut)**

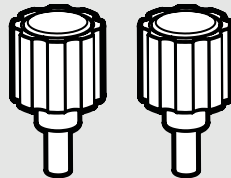
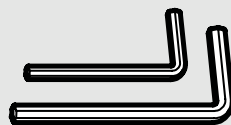

Table Lock Knobs (2)



6mm Flat Washers (2)



2mm and 4mm Hex Wrenches

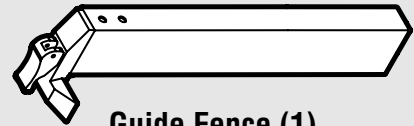

Guide Fence (1)

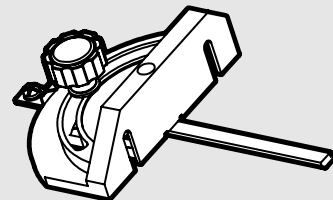

Miter Gauge (1)



10mm Wrench (1)

KNOW YOUR BAND SAW

TOOL PURPOSE

Make continuous and precise cuts with your WEN Band Saw. Refer to the following diagrams to become familiarized with all the parts and controls of your band saw. The components will be referred to later in the manual for assembly and operation instructions.

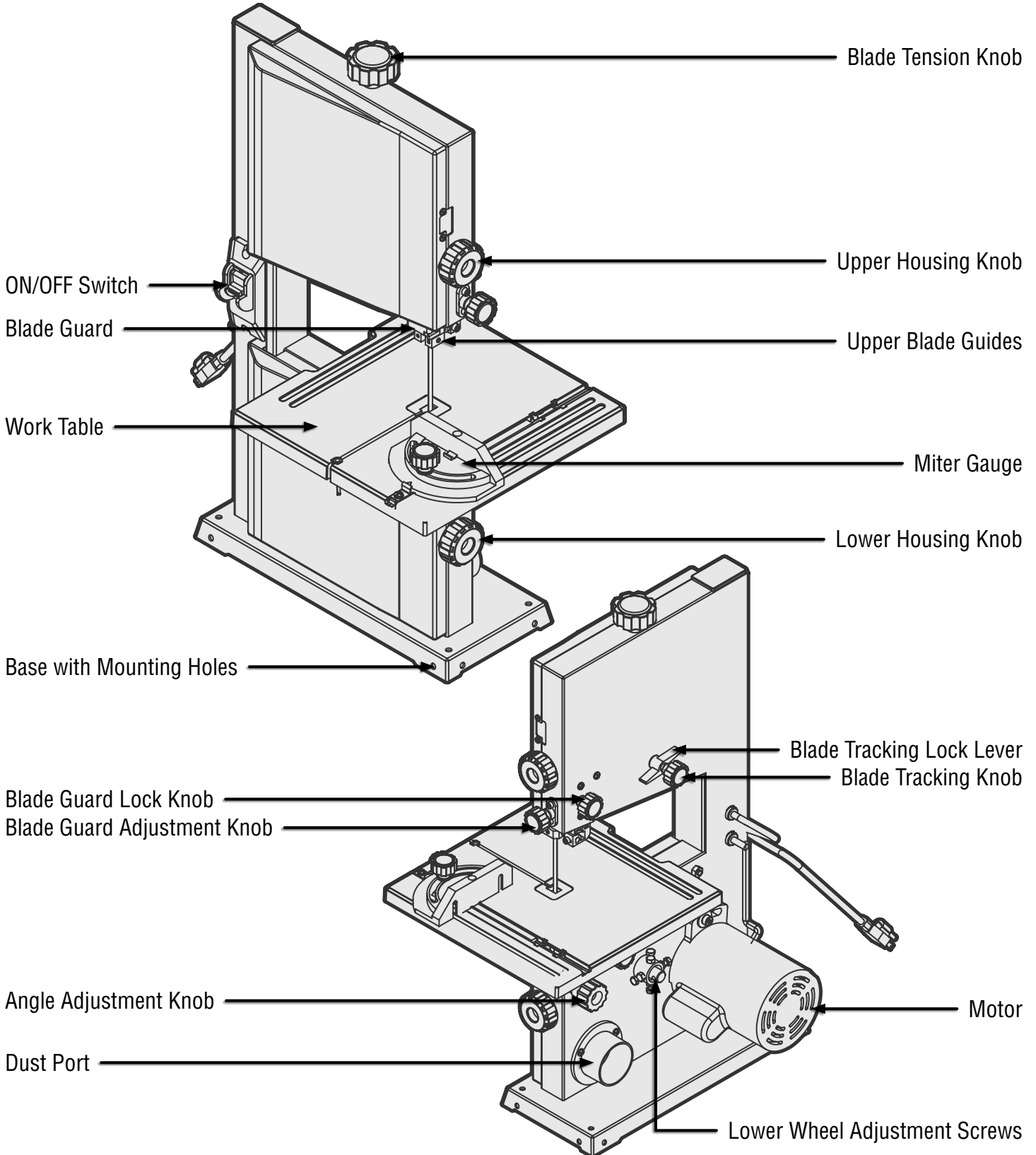

ASSEMBLY & ADJUSTMENTS

⚠ WARNING! Unplug the machine from the power source before assembly and making adjustments. Failure to comply may cause serious injury. Assembly requires at least two people to safely move around the band saw.

ASSEMBLING THE TABLE

1. Remove the M6x24 hex bolt, spring washer, flat washer and wing nut from the work table assembly (Fig. 2).
2. Slide the saw table onto the band saw, making sure that the blade stays within the slot in the table (Fig. 3).
3. Pull the angle adjustment knob (Fig. 4 - 1) on the back of the band saw and align the teeth on the table bracket into the teeth on the angle adjustment knob. Release the knob.
3. Assemble the flat washers and table lock knobs (Fig. 4 - 2) into the table bracket. Turn the table lock knobs to tighten the table assembly to the saw's frame.
4. Reattach the hex bolt, spring washer, flat washer and wing nut onto the front of the table (Fig. 2).

TILTING THE TABLE

1. Loosen the two table lock knobs located on the back of the band saw (Fig. 4 - 1).
2. Adjust the table to the desired angle using the angle adjustment knob (Fig. 4 - 2) and the angle indicator. The table can be tilted 45 degrees to the right.
3. Use the angle indicator to confirm the desired angle and tighten the table lock knobs.

NOTE: A table perpendicular to the blade corresponds to a scale indication of 0°.

MOUNTING THE BAND SAW

The band saw should be firmly attached to a reliable work surface. This will prevent the band saw from vibrating, walking or tipping during operation. Mount your band saw using bolts, flat washers, lock washers and hex nuts (not included) through the mounting holes on the base of the saw (Fig. 5 - 1).

CONNECTING TO THE DUST COLLECTION

Connect your band saw to the dust collection system of your choice (not included) using the dust port on the back of the unit (Fig. 5 - 2). The outer diameter of the port is 2-1/2 inches. Hose adaptors (not included) may be needed depending on the size of your dust hose.

NOTE: Always operate in a well-ventilated area and use dust collection systems whenever possible.

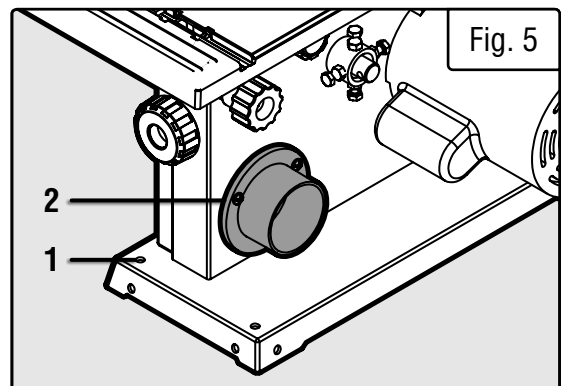
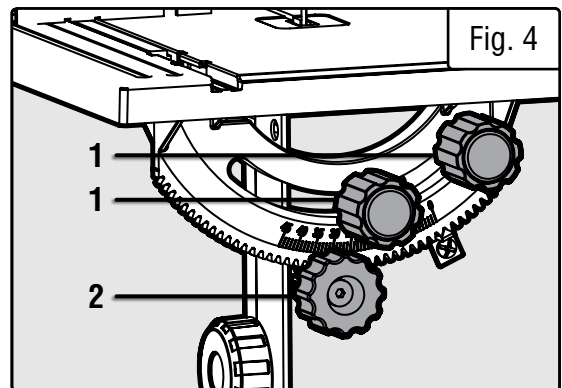
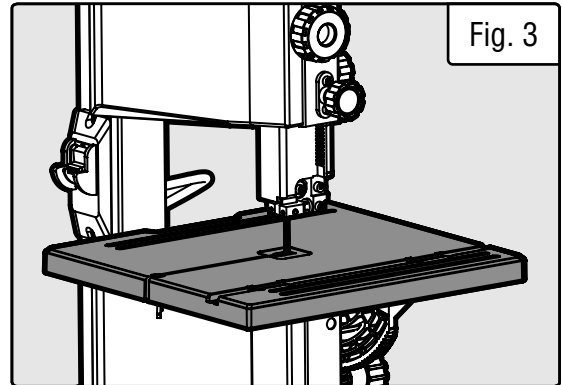
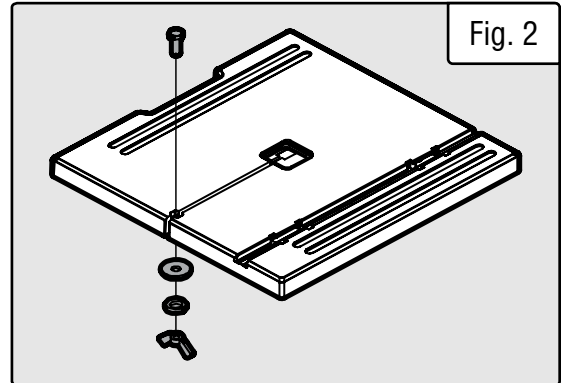

ASSEMBLY & ADJUSTMENTS

⚠ WARNING! Always be sure that the tool is switched off and unplugged before making any adjustments. Wear work gloves when handling saw blades. Failure to comply may cause serious injury.

SAW BLADE TRACKING

Before initial cutting and after every blade change, check and adjust blade tracking so that the blade runs on the center of the wheels.

1. Turn off the band saw and unplug it from the power supply. Make sure that the blade is not moving, then open both the upper and lower wheel covers (Fig. 6).

2. Stand to the side of the saw in the position shown in Fig. 7. Carefully rotate the upper wheel (Fig. 7 - 1) manually for at least three rotations (making sure not to touch the blade) and watch the blade travel. If the blade is veering off to either side of the wheel, follow the next step to adjust blade tracking.

3. Loosen the blade tracking lock (Fig. 7 - 2). Continue to rotate the wheel and slowly turn the blade tracking knob (Fig. 7 - 3) in the desired direction until the blade is centered over the wheels. Turning the blade tracking knob towards you shifts the blade to the left, and turning it away from you shifts the blade to the right.

4. Spin the wheel a few more turns to ensure that the blade is now running consistently in the center of the wheel. Close and lock the covers.

NOTE: Blade tracking will be more difficult with thinner blades, but don't be frustrated. Keep at it and you'll get there!

ADJUSTING THE BLADE TENSION

Proper tensioning of the blade is important before operating the band saw. If the tension in the blade is too high, it runs the risk of breaking. If the tension is too low, there is a risk of the blade slipping and stopping during a cut.

1. Loosen the blade guard lock knob located on the back of the saw (Fig. 8 - 1). Raise the blade guard to the top by turning the blade guard adjustment knob (Fig. 8 - 2). Lock the blade guard.

2. Check the tension by tapping with a finger against the side of the blade halfway between the table and the upper guide. The blade should not flex more than 2 mm.

WARNING: Wear protective gloves when handling saw blades.

3. Turn the tension knob (Fig. 8 - 3) clockwise to increase the blade tension or counterclockwise to decrease tension. Check and adjust the tension as necessary to make sure the blade is properly tensioned.

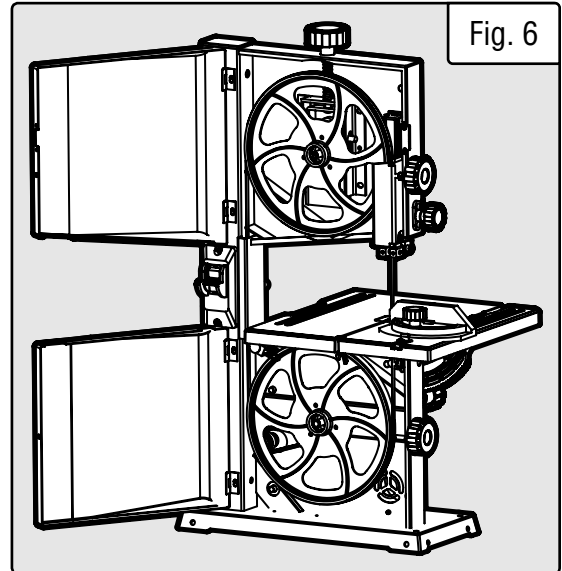

Fig. 6

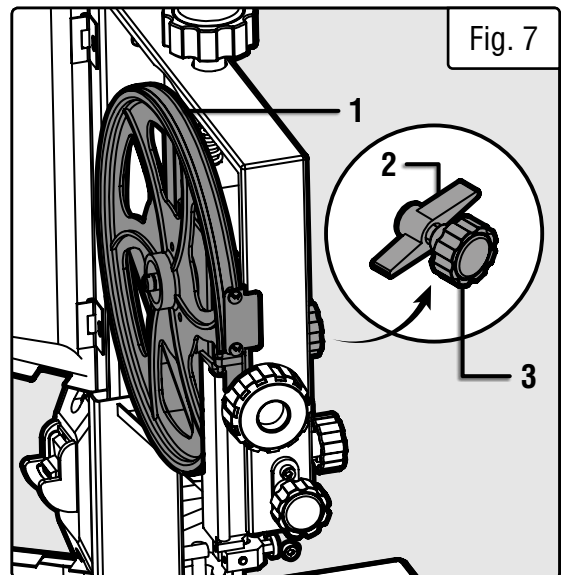

Fig. 7

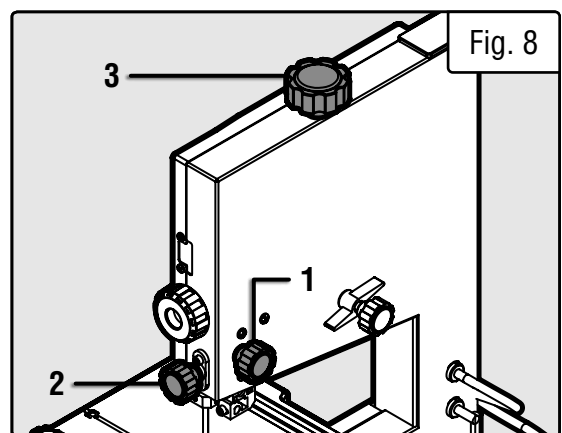

Fig. 8

ASSEMBLY & ADJUSTMENTS

UPPER BLADE GUIDES ADJUSTMENT

The upper blade guides need to be readjusted after every blade change or blade tracking adjustment.

1. Upper Thrust Bearing (Fig. 9 - 1):

Loosen the upper right screw (Fig. 9 - 2) using the S4 hex wrench to adjust the position of the thrust bearing running along the back of the blade (Fig. 9 - 1). The bearing should be positioned 0.5 mm from the back of the blade (Fig. 10). Retighten the screw (Fig. 9 - 2).

2. Upper Side Guides (Fig. 9 - 5):

Loosen the two set screws (Fig. 9 - 4) using the S2 hex wrench to adjust the two side guides at either side of the blade. The side guides should be positioned 0.25 mm away from the blade (Fig. 10). Retighten the set screws (Fig. 9 - 4).

Loosen the lower right screw (Fig. 9 - 3) using the S4 hex wrench. Move the screw to position the side guides 1 to 2 mm from the teeth of the blade (Fig. 10). Retighten the screw (Fig. 9 - 3).

LOWER BLADE GUIDES ADJUSTMENT

The lower blade guide needs to be readjusted after every blade change or blade tracking adjustment.

1. Open the lower wheel cover. The table might need to be removed for easier access to the adjustment screws.

2. The procedure is the same as adjusting the upper guides. Loosen the lower screw (Fig. 11 - 2) to adjust the thrust bearing 0.5 mm from the back of the blade. Loosen the upper screw (Fig. 11 - 1) to adjust the side guides 1 - 2 mm from the teeth of the blade. Loosen the two set screws (Fig. 11 - 3) to adjust the side guides 0.25 mm away from the either side of the blade.

3. Close the lower wheel cover.

BLADE GUARD ADJUSTMENT

The height of the upper blade guard (Fig. 12 - 1) should be adjusted prior to every operation to accommodate the height of the workpiece.

NOTE: The blade guard should be no more than 1/8 of an inch from the upper edge of the workpiece.

1. Loosen the blade guard locking knob located on the back of the saw (Fig. 12 - 2).

2. Turn the blade guard adjustment knob (Fig. 12 - 3) to adjust the height of the blade guard. Lock the upper blade guide locking knob to secure the guard in place once the desired height has been reached.

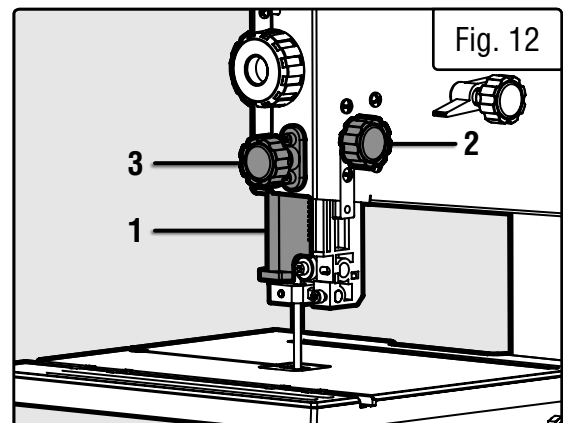
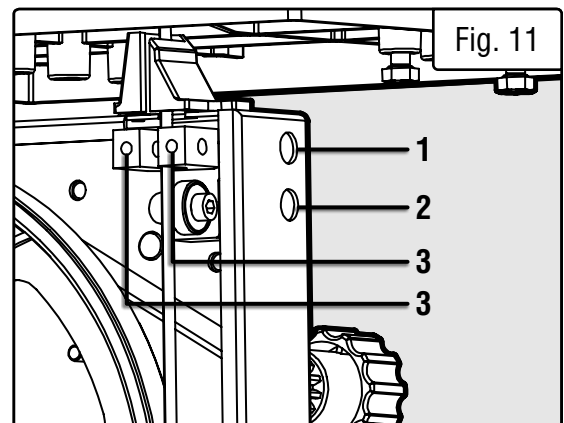
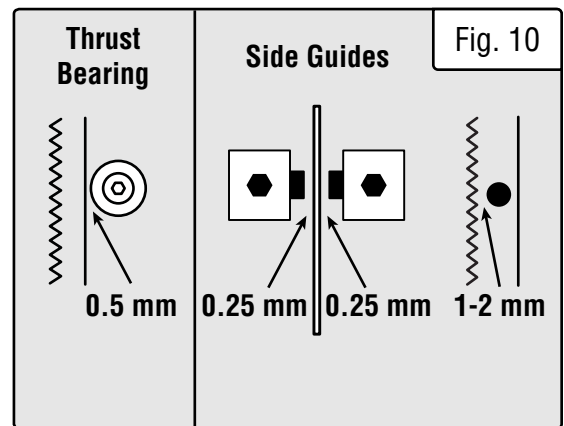
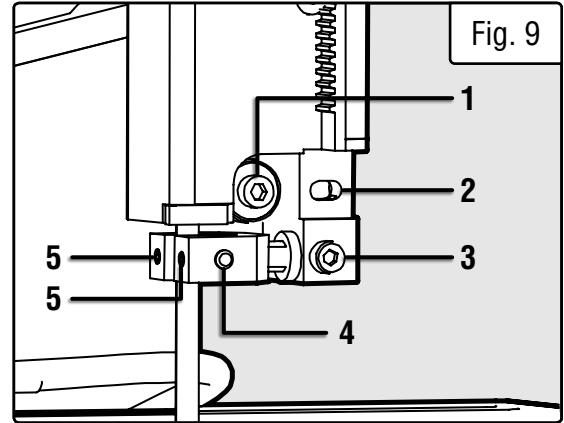

ASSEMBLY & ADJUSTMENTS

CHANGING THE BAND SAW BLADE

⚠ WARNING! Saw blades can be dangerous. Wear work gloves while handling the blade or when moving new blades from the packaging.

1. Remove the M6x24 hex bolt, spring washer, flat washer and wing nut from the work table assembly.
2. Open the upper and lower blade covers (Fig. 13).
3. Set the upper blade guard to its lowest position, minimizing the space between the bottom of the blade guard and the table assembly.
4. Open the blade guard cover (Fig. 14 - 1) by pinching the ridged surface on the bottom left of the cover and pulling it outwards.
5. Loosen the tension knob (Fig. 14 - 2) until you can remove the blade from the machine.

NOTE: Now is a good time to clean out your band saw to ensure the best performance. Clear out any sawdust, wood chips, etc. with a shop vacuum. Ensure that the wheels and tires are free of sawdust and chips. This promotes good wheel balance and good blade tracking.

6. Fit the new blade through the guiding slots on both the left and right sides of the machine onto the upper and lower rubber tires. Position the blade in the center of the rubber tires. Ensure that the blade teeth are pointing down towards the table.
7. Turn the blade tensioning knob clockwise to put the new blade under tension.
8. Close the upper blade guide assembly cover by pushing in until it clicks in place.
9. Replace the M6x24 hex bolt, spring washer, flat washer and wing nut onto the work table assembly.
10. After every blade change, make sure to follow the instructions on page 10 and 11 to adjust the tracking of the blade, the blade tension, and the upper and lower blade guides. Proper tuning of your band saw is necessary to ensure optimum performance of the machine.
11. After all adjustments and tuning are complete, close the upper and lower wheel covers.

We also made a video that takes you through the steps of installing and adjusting a bandsaw blade. Check it out at: <http://bit.ly/WENbandsaw>

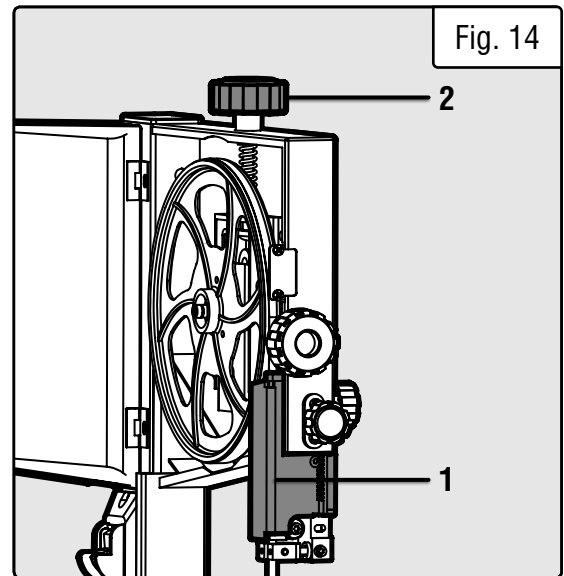
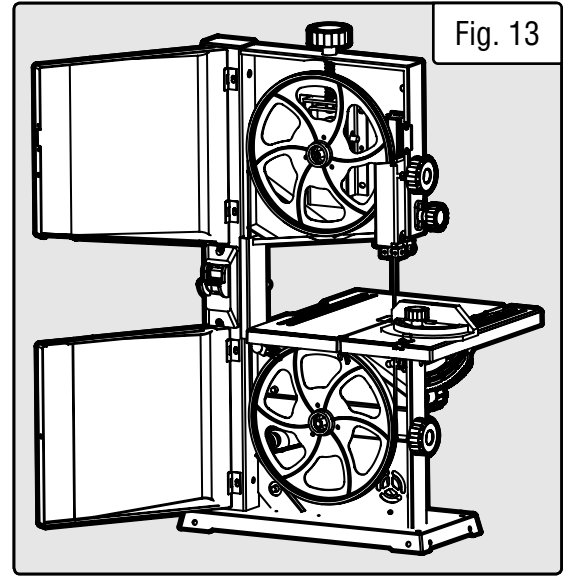

OPERATION

SUGGESTIONS AND WARNINGS:

- Do not touch the saw blade when cutting.
- During saw operation, wear safety glasses but do not wear gloves.
- Cut only one workpiece at a time.
- Always hold the workpiece down on the table.
- Do not jam any workpieces.
- Do not try to slow the blade down by pushing the work piece against the saw blade from the side.
- When straight cutting against the fence, use a push stick.
- Use a work support when cutting long stock to avoid pieces from falling down after cut has been completed.
- Use a dust collector to minimize sawdust.
- When cutting round stock, make sure the piece is as secure as possible.
- Before starting, check that the saw blade and the upper and lower blade guides are in proper working order.
- Replace damaged parts immediately.
- Assume the correct working position (the blade's teeth should be pointing towards the operator).
- Take all necessary precautions to avoid kickback during operation.

ON / OFF SWITCH

1. To turn the saw ON, move the switch (Fig. 15 - 1) to the up position. To turn the saw OFF, move the switch to the down (OFF) position.

2. To lock the switch in the OFF position:

- A) Wait until the band saw has come to a complete stop.
- B) Remove the safety key from the switch housing. Store the safety key in a safe place.

3. To unlock the switch and turn the saw ON, insert the safety key into the switch, and move the switch to the ON position.

USING THE MITER GAUGE

1. Place the miter gauge into the slot on the table (Fig. 16).
2. Loosen the knob on the gauge to set a new miter angle (between 0 and 60 degrees).
3. Tighten the knob firmly before cutting begins.

NOTE: A 0° cut is a straight cut that is perpendicular to the blade.

USING THE FENCE

The fence acts as a guide for making straight cuts. Position the fence onto the work table with the side face is parallel to the blade. Adjust the distance of the fence to the blade depending on the length you would like to cut. Lock it in place by pushing down on the fence lock handle(Fig. 17 - 1). Make sure the fence is locked down before operation.

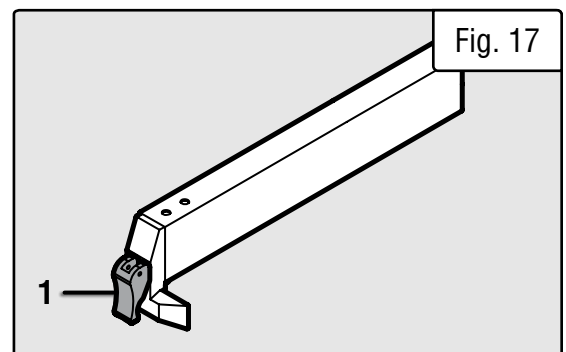
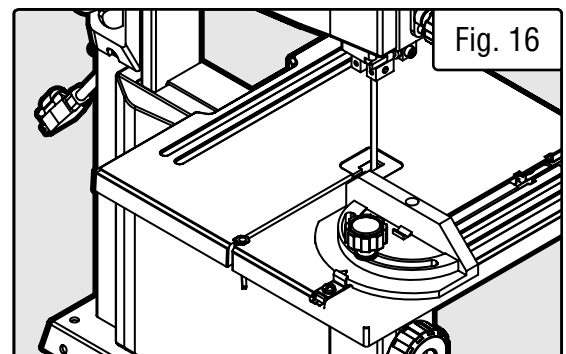
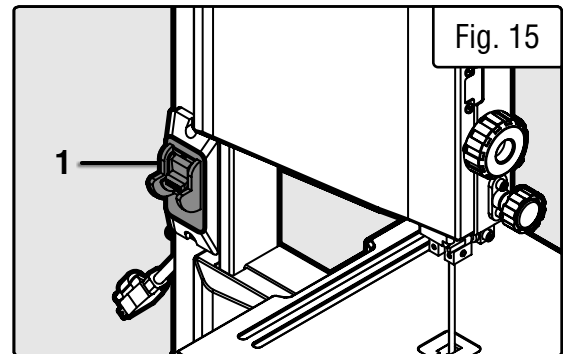

OPERATION

GENERAL CUTTING

⚠ WARNING! Operating a band saw involves a certain amount of risk. Make sure to read all the instructions and plan your work before cutting a workpiece. Wear safety goggles to protect your eyes from possible injury.

NOTE: Before cutting the actual workpiece, it's best to use a scrap piece of lumber to check the settings and to get the feel of operating the band saw.

1. Your band saw should now have been properly set up and tuned according to the instructions on page 9 - 11. Position the workpiece on the table and adjust the upper blade guard so that it barely clears the workpiece. The blade guard should be no more than 1/8 of an inch from the upper surface of the workpiece. Do not turn the power on until all adjustments have been made.

2. Use the band saw for straight line operations such as cross-cutting, ripping, miter cutting, beveling, compound cutting, and resawing. To avoid twisting the blade, do not turn sharp corners; instead, saw around corners. A band saw is not capable of doing intricate inside cutting as can be done with a scroll saw. Refer to the "Circle Cutting Guide for the minimum radius you can cut based on the width of the blade installed on your band saw.

⚠ WARNING! Do not use this band saw to cut ferrous metals.

CIRCLE CUTTING GUIDE

BLADE WIDTH	1/8 in.	3/16 in.	1/4 in.	3/8 in.	1/2 in.	3/4 in.	1 in.
MINIMUM RADIUS	3/16 in.	5/16 in.	5/8 in.	1-1/2 in.	2-1/2 in.	5-1/2 in.	7 in.

3. Slowly feed the workpiece into the saw blade. Light contact permits easier cutting and prevents unwanted friction and heating of the blade. Steadily move the workpiece through the blade without forcing it against the blade. Never position your hand in line with the cut. Always keep your hand at a safe distance from the saw blade. Use a push stick to assist cutting small workpieces.

4. When the cutting operation is complete, turn off the machine and wait for the blade to come to a complete stop before leaving the work area.

MAINTENANCE

⚠ WARNING! For your own safety, turn the switch OFF and remove the plug from the electrical outlet before performing maintenance or lubricating the band saw.

1. Clean off the pitch and dust which accumulates on the table, blade guides, and bearings.

2. Remove pitch and dust from the upper and lower wheels using a stiff brush. Do not use solvents.

3. Routinely remove the sawdust from the inside of the housing. Blow out the sawdust from the motor.

4. Apply a thin coat of automotive polish to the table top for a slick surface.

5. Regularly inspect the machine for any damaged or missing parts. Replace blades and the wheel tires when worn. Replace the power cord immediately if it is worn, cut, or damaged in any way. Release tension on the blade if the saw will not be used for longer than a week.

EXPLODED VIEW & PARTS LIST

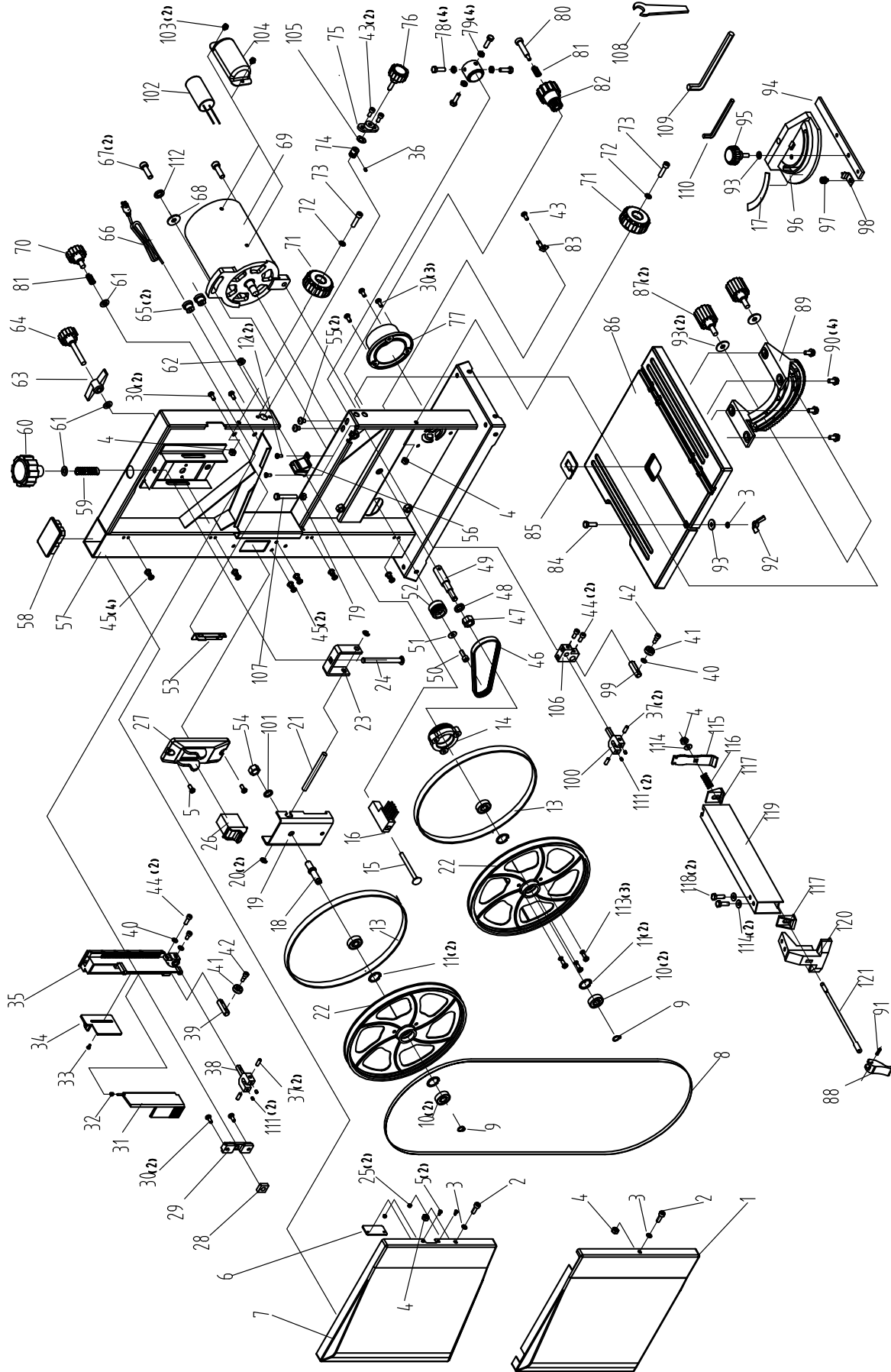

EXPLODED VIEW & PARTS LIST

No.	Part No.	Description	Qty.
1	3959-001	Lower Door	1
2	3959-002	Hex Screw M6X10	2
3	3959-003	Spring Washer 6	3
4	3959-004	Nut M6	5
5	3959-005	Screw M4X10	4
6	3959-006	Window	1
7	3959-007	Upper Door	1
8	3959-008	Saw Blade	1
9	3959-009	Shaft Circlip	2
10	3959-010	Bearing	4
11	3959-011	Hole Circlip 26	4
12	3959-012	Screw M4X8	2
13	3959-013	Rubber Gasket	2
14	3959-014	Driven Pulley	1
15	3959-015	M8X70 Bolt	1
16	3959-016	Brush	1
17	3959-017	Scale Label	1
18	3959-018	Upper Wheel Shaft	1
19	3959-019	Upper Wheel Shaft Base	1
20	3959-020	Split Washer M6	2
21	3959-021	Connection Shaft	1
22	3959-022	Blade Wheel	2
23	3959-023	U Type Support	1
24	3959-024	Bolt	1
25	3959-025	Hex Nut M4	2
26	3959-026	Switch	1
27	3959-027	Switch Plate	1
28	3959-028	Locking Washer	1
29	3959-029	Guide Base	1
30	3959-030	Screw	7
31	3959-031	Guide Cover	1
32	3959-032	Cover Spring	1
33	3959-033	Screw	1
34	3959-034	Slide Board	1

No.	Part No.	Description	Qty.
35	3959-035	Upper Guide Slide Bar	1
36	3959-036	Hex Screw M4X4	1
37	3959-037	Pin 5X14	4
38	3959-038	Upper Blade Guide Support	1
39	3959-039	Upper Support Shaft	1
40	3959-040	Flat Washer M5	3
41	3959-041	Ball Bearing	2
42	3959-042	Bearing Fastening Screw	2
43	3959-043	Hex Screw M5X10	3
44	3959-044	Hex Screw M5X12	4
45	3959-045	Philips Screw+Flat Washer+Spring Washer Assembly M4X8	6
46	3959-046	Belt	1
47	3959-047	Hex Nut M12X1.5	1
48	3959-048	Spring Washer M12	1
49	3959-049	Lower Wheel Shaft	1
50	3959-050	Hex Screw M5X10	1
51	3959-051	Big Flat Washer	1
52	3959-052	Driven Pulley	1
53	3959-053	Guide Plate	1
54	3959-054	Hex Nut M10	1
55	3959-055	Hex Screw M6X8	2
56	3959-056	Blade Lower Guard	1
57	3959-057	Saw Body	1
58	3959-058	Block	1
59	3959-059	Tension Spring	1
60	3959-060	Tension Handle	1
61	3959-061	Flat Washer D8	2
62	3959-062	Hex Nut M8	1
63	3959-063	Wing Locking Nut	1
64	3959-064	Blade Wheel Adjusting Knob	1
65	3959-065	6P4 Clip	2

NOTE: Not all parts may be available for purchase. Parts and accessories that wear down over the course of normal use are not covered under the warranty.

EXPLODED VIEW & PARTS LIST

No.	Part No.	Description	Qty.
66	3959-066	Power Cord	1
67	3959-067	Hex Screw M8X25	2
68	3959-068	Flat Washer M8	1
69	3959-069	Motor	1
70	3959-070	Locking Knob	1
71	3959-071	Eccentric Locking Knob	2
72	3959-072	Flat Washer D6	2
73	3959-073	Hex Screw M6X25	2
74	3959-074	Adjusting Gear	1
75	3959-075	Adjusting Handle Base	1
76	3959-076	Adjusting Handle	1
77	3959-077	Dust Port	1
78	3959-078	Hex Bolt M6X20	4
79	3959-079	Hex Nut M6	5
80	3959-080	Shaft	1
81	3959-081	Locking Spring	2
82	3959-082	Gear Handle	1
83	3959-083	Table Pointer	1
84	3959-084	Hex Bolt M6X25	1
85	3959-085	Table Insert	1
86	3959-086	Work Table	1
87	3959-087	Table Locking Knob	2
88	3959-088	Fence Locking Knob	1
89	3959-089	Angle Support	1
90	3959-090	Hex Bolt M6X12	4
91	3959-091	Pin 3X16	1
92	3959-092	Butterfly Nut M6	1
93	3959-093	Flat Washer D6	4
94	3959-094	Slide Bar	1
95	3959-095	Miter Gauge Knob	1
96	3959-096	Miter Gauge	1
97	3959-097	Philips Screw+Flat Washer+Spring Washer Assembly M5X8	1

No.	Part No.	Description	Qty.
98	3959-098	Miter Gauge Pointer	1
99	3959-099	Lower Support Shaft	1
100	3959-100	Lower Blade Guide Support	1
101	3959-101	Spring Washer D10	1
102	3959-102	Capacitor	1
103	3959-103	Philips Screw+Flat Washer M4X6	2
104	3959-104	Capacitor Box	1
105	3959-105	Wavy Washer ϕ 6	1
106	3959-106	Lower Blade Guide Support Base	1
107	3959-107	Hex Bolt M6X40	1
108	3959-108	Wrench S=10	1
109	3959-109	Hex Wrench S=4	1
110	3959-110	Hex Wrench S=2	1
111	3959-111	Screw M4X8	4
112	3959-112	Spring Washer D8	1
113	3959-113	Screw M5X16	3
114	3959-114	Flat Washer D6	3
115	3959-115	Fence Locking Plate	1
116	3959-116	Fence Locking Spring	1
117	3959-117	Fence Washer	2
118	3959-118	Hex Bolt M6X16	2
119	3959-119	Fence Plate	1
120	3959-120	Fence Work Rest	1
121	3959-121	Bolt	1

NOTE: Not all parts may be available for purchase. Parts and accessories that wear down over the course of normal use are not covered under the warranty.

WARRANTY STATEMENT

WEN Products is committed to building tools that are dependable for years. Our warranties are consistent with this commitment and our dedication to quality.

LIMITED WARRANTY OF WEN PRODUCTS FOR HOME USE

GREAT LAKES TECHNOLOGIES, LLC (“Seller”) warrants to the original purchaser only, that all WEN consumer power tools will be free from defects in material or workmanship during personal use for a period of two (2) years from date of purchase or 500 hours of use; whichever comes first. Ninety days for all WEN products if the tool is used for professional or commercial use. Purchaser has 30 days from the date of purchase to report missing or damaged parts.

SELLER’S SOLE OBLIGATION AND YOUR EXCLUSIVE REMEDY under this Limited Warranty and, to the extent permitted by law, any warranty or condition implied by law, shall be the replacement of parts, without charge, which are defective in material or workmanship and which have not been subjected to misuse, alteration, careless handling, misrepair, abuse, neglect, normal wear and tear, improper maintenance, or other conditions adversely affecting the Product or the component of the Product, whether by accident or intentionally, by persons other than Seller. To make a claim under this Limited Warranty, you must make sure to keep a copy of your proof of purchase that clearly defines the Date of Purchase (month and year) and the Place of Purchase. Place of Purchase must be a direct vendor of Great Lakes Technologies, LLC. Purchasing through third party vendors, including but not limited to garage sales, pawn shops, resale shops, or any other secondhand merchant, voids the warranty included with this product. Contact techsupport@wenproducts.com or 1-800-232-1195 with the following information to make arrangements: your shipping address, phone number, serial number, required part numbers, and proof of purchase. Damaged or defective parts and products may need to be sent to WEN before the replacements can be shipped out.

Upon the confirmation of a WEN representative, your product may qualify for repairs and service work. When returning a product for warranty service, the shipping charges must be prepaid by the purchaser. The product must be shipped in its original container (or an equivalent), properly packed to withstand the hazards of shipment. The product must be fully insured with a copy of the proof of purchase enclosed. There must also be a description of the problem in order to help our repairs department diagnose and fix the issue. Repairs will be made and the product will be returned and shipped back to the purchaser at no charge for addresses within the contiguous United States.

THIS LIMITED WARRANTY DOES NOT APPLY TO ITEMS THAT WEAR OUT FROM REGULAR USAGE OVER TIME, INCLUDING BELTS, BRUSHES, BLADES, BATTERIES, ETC. ANY IMPLIED WARRANTIES SHALL BE LIMITED IN DURATION TO TWO (2) YEARS FROM DATE OF PURCHASE. SOME STATES IN THE U.S. AND SOME CANADIAN PROVINCES DO NOT ALLOW LIMITATIONS ON HOW LONG AN IMPLIED WARRANTY LASTS, SO THE ABOVE LIMITATION MAY NOT APPLY TO YOU.

IN NO EVENT SHALL SELLER BE LIABLE FOR ANY INCIDENTAL OR CONSEQUENTIAL DAMAGES (INCLUDING BUT NOT LIMITED TO LIABILITY FOR LOSS OF PROFITS) ARISING FROM THE SALE OR USE OF THIS PRODUCT. SOME STATES IN THE U.S. AND SOME CANADIAN PROVINCES DO NOT ALLOW THE EXCLUSION OR LIMITATION OF INCIDENTAL OR CONSEQUENTIAL DAMAGES, SO THE ABOVE LIMITATION OR EXCLUSION MAY NOT APPLY TO YOU.

THIS LIMITED WARRANTY GIVES YOU SPECIFIC LEGAL RIGHTS, AND YOU MAY ALSO HAVE OTHER RIGHTS WHICH VARY FROM STATE TO STATE IN THE U.S., PROVINCE TO PROVINCE IN CANADA AND FROM COUNTRY TO COUNTRY.

THIS LIMITED WARRANTY APPLIES ONLY TO ITEMS SOLD WITHIN THE UNITED STATES OF AMERICA, CANADA AND THE COMMONWEALTH OF PUERTO RICO. FOR WARRANTY COVERAGE WITHIN OTHER COUNTRIES, CONTACT THE WEN CUSTOMER SUPPORT LINE. FOR WARRANTY PARTS OR PRODUCTS REPAIRED UNDER WARRANTY SHIPPING TO ADDRESSES OUTSIDE OF THE CONTIGUOUS UNITED STATES, ADDITIONAL SHIPPING CHARGES MAY APPLY.