

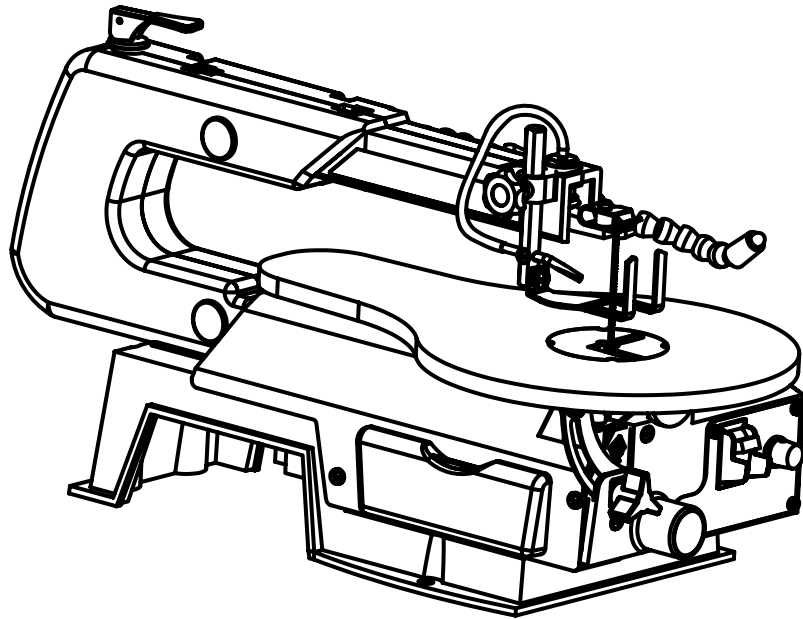

16" VARIABLE SPEED SCROLL SAW



Model # 3921
bit.ly/wenvideo

IMPORTANT:

Your new tool has been engineered and manufactured to WEN's highest standards for dependability, ease of operation, and operator safety. When properly cared for, this product will supply you years of rugged, trouble-free performance. Pay close attention to the rules for safe operation, warnings, and cautions. If you use your tool properly and for intended purpose, you will enjoy years of safe, reliable service.

NEED HELP? CONTACT US!

Have product questions? Need technical support?
Please feel free to contact us at:



800-232-1195 (M-F 8AM-5PM CST)



techsupport@wenproducts.com



WENPRODUCTS.COM



TABLE OF CONTENTS

Technical Data	2
General Safety Rules	3
Specific Safety Rules For Scroll Saw	5
Electrical Information	6
Know Your Scroll Saw	8
Assembly and Adjustments.....	9
Operation	15
Maintenance	19
Exploded View and Parts List	20
Warranty	22

TECHNICAL DATA

Model Number:	3921
Motor:	120 V, 60 Hz, 1.2 A
Speed:	550 to 1600 SPM
Throat Depth:	16"
Blade:	5" pinned & pinless
Blade Stroke:	9/16"
Cutting Capacity:	2" at 90°
Table tilt:	0° to 45° left
Overall dimensions:	26 - 3/8" by 13" by 14 - 3/4"
Weight:	27.5 lb
Includes:	15 TPI Pinned Blade 18 TPI Pinned Blade 18 TPI Pinless Blade

GENERAL SAFETY RULES

Safety is a combination of common sense, staying alert and knowing how your item works.

SAVE THESE SAFETY INSTRUCTIONS.



WARNING: To avoid mistakes and serious injury, do not plug in your tool until the following steps have been read and understood.

1. **READ** and become familiar with this entire instruction manual. **LEARN** the tool's applications, limitations, and possible hazards.
2. **AVOID DANGEROUS CONDITIONS.** Do not use power tools in wet or damp areas or expose them to rain. Keep work areas well lit.
3. **DO NOT** use power tools in the presence of flammable liquids or gases.
4. **ALWAYS** keep your work area clean, uncluttered, and well lit. **DO NOT** work on floor surfaces that are slippery with sawdust or wax.
5. **KEEP BYSTANDERS AT A SAFE DISTANCE** from the work area, especially when the tool is operating. **NEVER** allow children or pets near the tool.
6. **DO NOT FORCE THE TOOL** to do a job for which it was not designed.
7. **DRESS FOR SAFETY.** Do not wear loose clothing, gloves, neckties, or jewelry (rings, watches, etc.) when operating the tool. Inappropriate clothing and items can get caught in moving parts and draw you in. **ALWAYS** wear non-slip footwear and tie back long hair.
8. **WEAR A FACE MASK OR DUST MASK** to fight the dust produced by sawing operations.



WARNING: Dust generated from certain materials can be hazardous to your health. Always operate the tool in a well-ventilated area and provide for proper dust removal. Use dust collection systems whenever possible.

9. **ALWAYS** remove the power cord plug from the electrical outlet when making adjustments, changing parts, cleaning, or working on the tool.
10. **KEEP GUARDS IN PLACE AND IN WORKING ORDER.**
11. **AVOID ACCIDENTAL START-UPS.** Make sure the power switch is in the **OFF** position before plugging in the power cord.
12. **REMOVE ADJUSTMENT TOOLS.** Always make sure all adjustment tools are removed from the saw before turning it on.
13. **NEVER LEAVE A RUNNING TOOL UNATTENDED.** Turn the power switch to **OFF**. Do not leave the tool until it has come to a complete stop.
14. **NEVER STAND ON A TOOL.** Serious injury could result if the tool tips or is accidentally hit. **DO NOT** store anything above or near the tool.

GENERAL SAFETY RULES

15. **DO NOT OVERREACH.** Keep proper footing and balance at all times. Wear oil-resistant rubber-soled footwear. Keep the floor clear of oil, scrap, and other debris.
16. **MAINTAIN TOOLS PROPERLY.** ALWAYS keep tools clean and in good working order. Follow instructions for lubricating and changing accessories.
17. **CHECK FOR DAMAGED PARTS.** Check for alignment of moving parts, jamming, breakage, improper mounting, or any other conditions that may affect the tool's operation. Any part that is damaged should be properly repaired or replaced before use.
18. **MAKE THE WORKSHOP CHILDPROOF.** Use padlocks and master switches and ALWAYS remove starter keys.
19. **DO NOT** operate the tool if you are under the influence of drugs, alcohol, or medication that may affect your ability to properly use the tool.
20. **USE SAFETY GOGGLES AT ALL TIMES** that comply with ANSI Z87.1. Normal safety glasses only have impact resistant lenses and are not designed for safety. Wear a face or dust mask when working in a dusty environment. Use ear protection such as plugs or muffs during extended periods of operation.

SPECIFIC RULES FOR THE SCROLL SAW



WARNING: Do not operate the scroll saw until it is assembled and adjusted. Do not operate the scroll saw until you have read and understood both the following instructions and the warning labels on the scroll saw.

BEFORE OPERATING:

1. Check for both proper assembly and proper alignment of moving parts.
2. Understand the function and proper use of the ON/OFF switch.
3. Know the condition of the scroll saw. If any part is missing, bent, or does not operate properly, replace the component before attempting to operate the scroll saw.
4. Determine the type of work you are going to be doing. Properly protect your body including your eyes, hands, face, and ears.
5. To avoid injury caused by pieces thrown from accessories, use only recommended accessories designed for this saw. Follow the instructions supplied with the accessory. The use of improper accessories may cause risk of injury.
6. To avoid contact with rotating equipment:
 - Do not put your fingers in a position where they risk contacting the blade if the work piece unexpectedly shifts or your hand unexpectedly slips.
 - Do not cut a work piece too small to be held safely.
 - Do not reach under the scroll saw table when the motor is running.
 - Do not wear loose clothing or jewelry. Roll long sleeves above the elbow. Tie back long hair.

SPECIFIC RULES FOR THE SCROLL SAW

7. To avoid injury from accidental startups of the scroll saw:
 - Make sure to turn **OFF** the switch and unplug the power cord from the electric outlet before changing the blade, performing maintenance or making adjustments.
 - Make sure the switch is **OFF** before plugging in the power cord to an electric outlet.
8. To avoid injury from a fire hazard, do not operate the scroll saw near flammable liquids, vapors or gases.
9. To avoid back injury:
 - Obtain help when raising the scroll saw more than 10 inches (25.4 cm). **Bend your knees** when lifting the scroll saw.
 - Carry the scroll saw by its base. **Do not** move the scroll saw by pulling on the power cord. Pulling on the power cord could cause damage to the insulation or the wire connections resulting in electric shock or fire.

WHEN OPERATING THE SCROLL SAW

1. To avoid injury from unexpected scroll saw movement:
 - Use the scroll saw on a firm level surface with adequate space for handling and supporting the work piece.
 - Be sure the scroll saw cannot move when operated. Secure the scroll saw to a workbench or table with wood screws or bolts, washers and nuts.
2. Before moving the scroll saw, unplug the power cord from the electrical outlet.
3. To avoid injury from kickback:
 - Hold the work piece firmly against the tabletop.
 - Do not feed the work piece too fast while cutting. Only feed the work piece at the rate the saw will cut.
 - Install the blade with the teeth pointing downward.
 - Do not start the saw with the work piece pressing against the blade. Slowly feed the work piece into the moving blade.
 - Use caution when cutting round or irregularly shaped work pieces. Round items will roll and irregularly shaped work pieces can pinch the blade.
4. To avoid injury when operating the scroll saw:
 - Obtain advice from a qualified person if you're not thoroughly familiar with the operation of scroll saws.
 - Before starting the saw, make sure the blade tension is correct. Recheck and adjust tension as needed.
 - Make sure the table is locked into position before starting the saw.
 - Do not use dull or bent blades.
 - When cutting a large work piece, make sure the material is supported at the table height.
 - Turn the saw **OFF** and unplug the power cord if the blade jams in the work piece. This condition is usually caused by sawdust clogging the line you are cutting. Wedge open the work piece and back out the blade after turning off and unplugging the machine.

ELECTRICAL INFORMATION

GROUNDING INSTRUCTIONS

IN THE EVENT OF A MALFUNCTION OR BREAKDOWN, grounding provides the path of least resistance for an electric current and reduces the risk of electric shock. This tool is equipped with an electric cord that has an equipment grounding conductor and a grounding plug. The plug **MUST** be plugged into a matching outlet that is properly installed and grounded in accordance with **ALL** local codes and ordinances.

DO NOT MODIFY THE PLUG PROVIDED. If it will not fit the outlet, have the proper outlet installed by a licensed electrician.

IMPROPER CONNECTION of the equipment grounding conductor can result in electric shock. The conductor with the green insulation (with or without yellow stripes) is the equipment grounding conductor. If repair or replacement of the electric cord or plug is necessary, **DO NOT** connect the equipment grounding conductor to a live terminal.

CHECK with a licensed electrician or service personnel if you do not completely understand the grounding instructions or whether the tool is properly grounded.

USE ONLY THREE-WIRE EXTENSION CORDS that have three-pronged plugs and outlets that accept the tool's plug as shown in Fig. A. Repair or replace a damaged or worn cord immediately.



CAUTION: In all cases, make certain the outlet in question is properly grounded. If you are not sure, have a licensed electrician check the outlet.

WARNING: This tool is for indoor use only. Do not expose to rain or use in damp locations.

AMPERAGE	REQUIRED GAUGE FOR EXTENSION CORDS			
	25 ft.	50 ft.	100 ft.	150 ft.
1.2 A	18 gauge	16 gauge	16 gauge	14 gauge

Make sure your extension cord is in good condition. When using an extension cord, be sure to use one heavy enough to carry the current your product will draw. An undersized cord will cause a drop in line voltage resulting in loss of power and overheating. The table below shows the correct size to be used according to cord length and nameplate ampere rating. When in doubt, use a heavier cord. The smaller the gauge number, the heavier the cord.

Make sure your extension cord is properly wired and in good condition. Always replace a damaged extension cord or have it repaired by a qualified person before using it.

Protect your extension cords from sharp objects, excessive heat and damp/wet areas.

Use a separate electrical circuit for your tools. This circuit must not be less than a #12 wire and should be protected with a 15 A time-delayed fuse. Before connecting the motor to the power line, make sure the switch is in the **OFF** position and the electric current is rated the same as the current stamped on the motor nameplate. Running at a lower voltage will damage the motor.

WARNING: This tool must be grounded while in use to protect the operator from electric shock.

KNOW YOUR SCROLL SAW

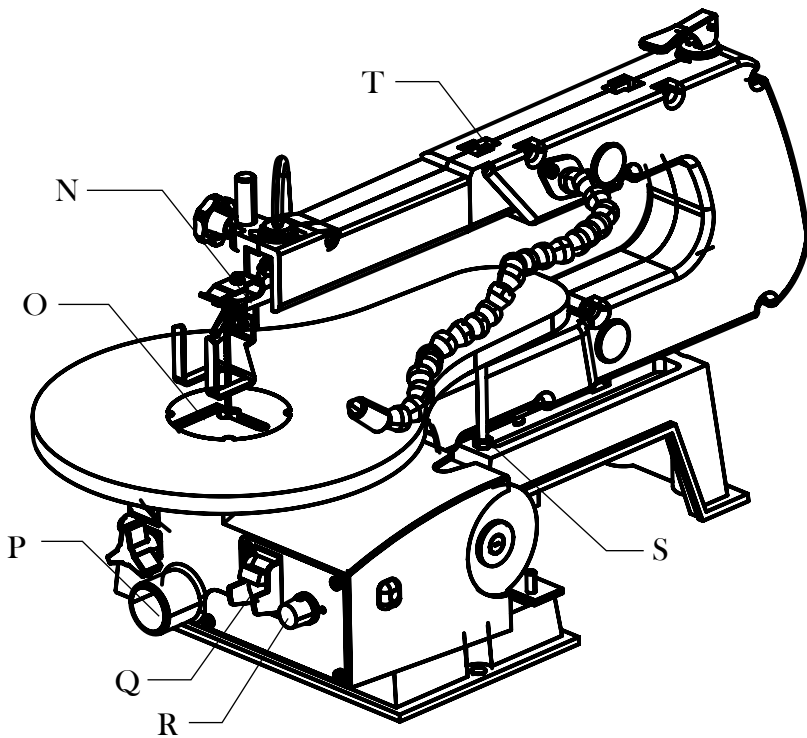
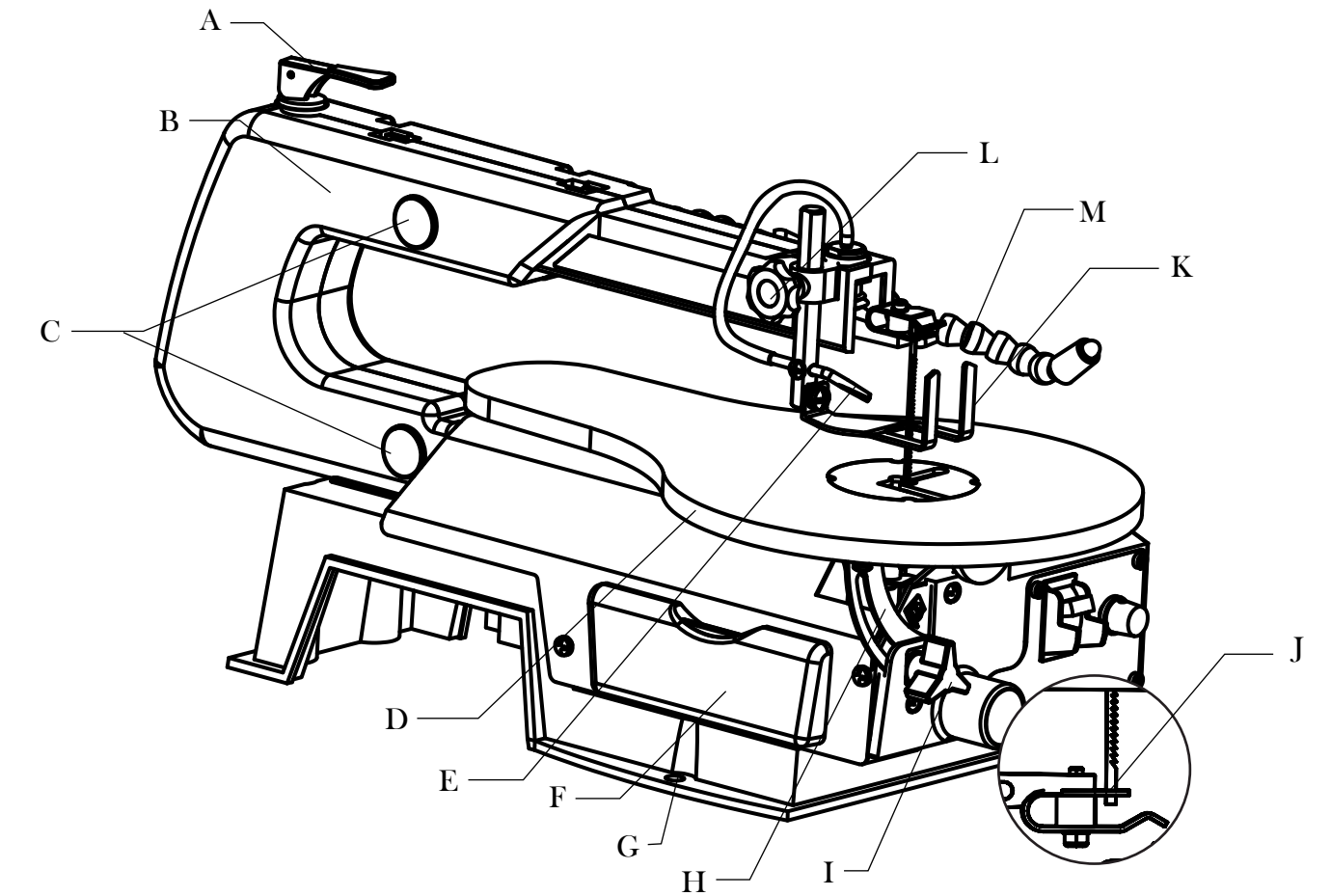

- A - Blade Tension Knob
- B - Arm Housing
- C - Rubber Bearing Covers
- D - Table
- E - Sawdust Blower
- F - Storage Area
- G - Base
- H - Bevel Scale and Pointer
- I - Table/Bevel Lock Knob
- J - Lower Blade Holder
- K - Blade Guard Foot
- L - Blade Guard Root Lock Knob
- M - LED Light
- N - Upper Blade Holder
- O - Table Insert
- P - Sawdust Collection Port
- Q - ON/OFF Switch
- R - Speed Control Knob
- S - Table Adjusting Screw
- T - Pinless Blade Holder

ASSEMBLY AND ADJUSTMENTS

UNPACKING

Carefully unpack the scroll saw and all of its parts. Compare them against the list below. Do not discard the carton or any packaging until the scroll saw is completely assembled.



CAUTION: do not lift the saw by the arm that holds the blade. The saw will be damaged.

WARNING: To avoid injury from accidental startups, turn switch OFF and remove the plug from the power source outlet before making any adjustments.

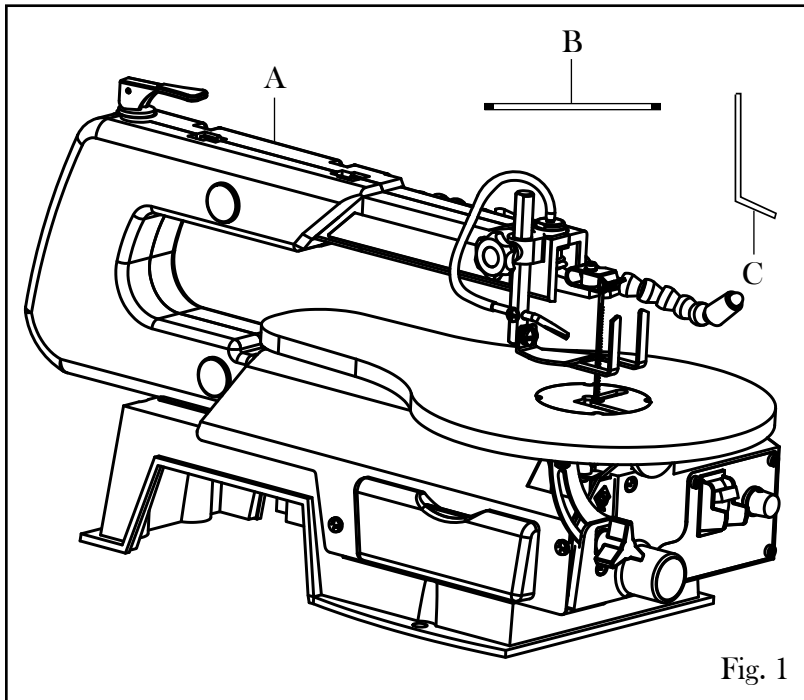

INCLUDES (Fig. 1)

- A - Scroll saw with attached light
- B - Extra pin blade

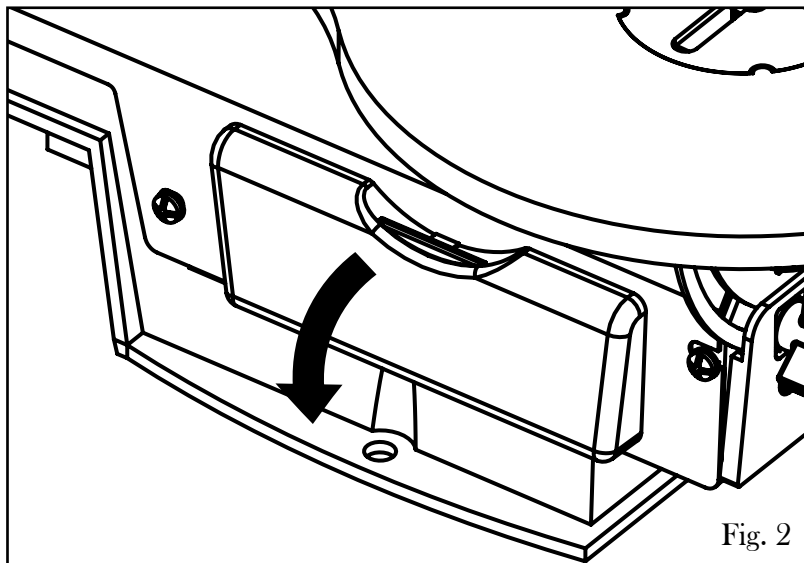

STORAGE AREA (Fig. 2)

A convenient storage location for the extra blade can be found beneath the saw's table.

ASSEMBLY AND ADJUSTMENTS

Prior to making adjustments, mount the scroll saw on a stable surface. See “Bench mounting the saw.”

ALIGN THE BEVEL INDICATOR (Fig. 3-6)

The bevel indicator has been factory adjusted. It should be rechecked prior to use for best operation.

1. Remove the blade guard foot (1) using a Phillips head screwdriver (not included) to loosen the screw (2).

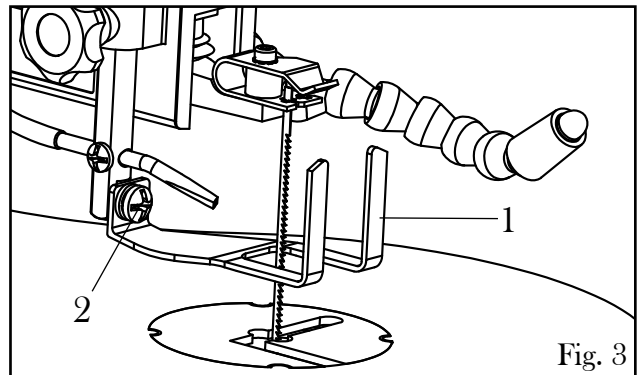

2. Loosen the table bevel lock knob (3) and move the table until it is approximately at a right angle to the blade.

3. Loosen the locking nut (5) on the table adjusting screw (6) under the table by turning it counter-clockwise. Lower the table adjusting screw by turning it clockwise.

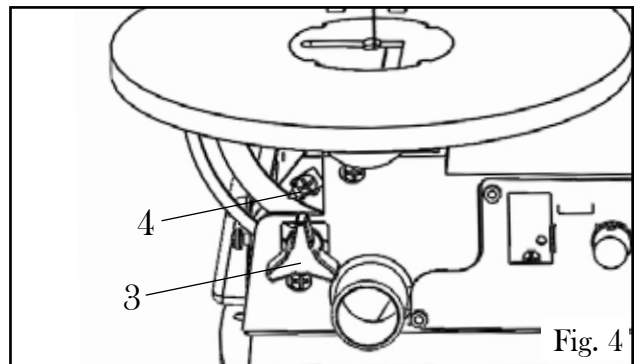

4. Use a combination square (7) to set the table exactly 90° to the blade (8). If there is space between the square and blade, adjust the table angle until the space is closed.

5. Lock the table bevel lock knob under the table (3) to prevent movement.

6. Tighten the adjusting screw under the table until the tip of the screw touches the table. Tighten the lock nut.

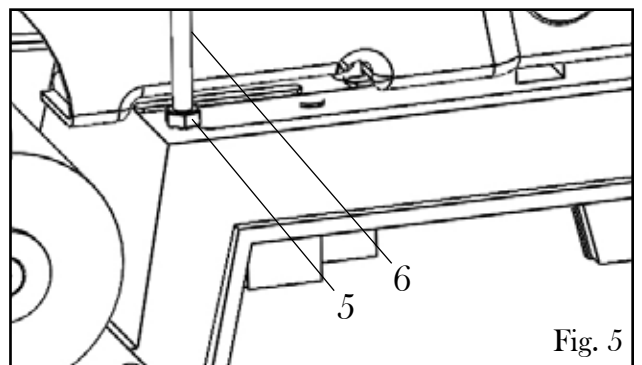

7. Loosen the screw (4) holding the bevel scale pointer and position pointer to 0°. Tighten the screw.

8. Attach the blade guard foot (1) so the foot rests flat against the table. Tighten the screw (2) using a Phillips head screwdriver (not included).

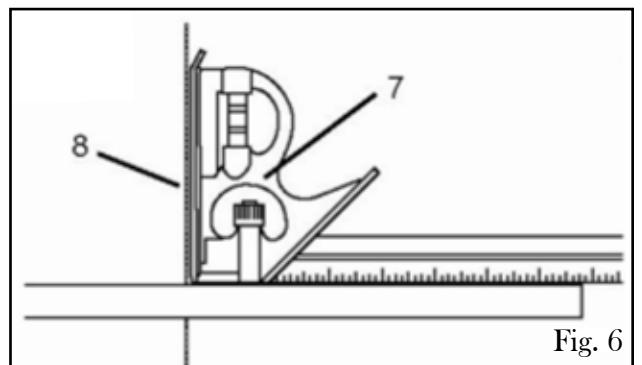

Note: Avoid setting the edge of the table against the top of the motor. This can cause excess noise when the saw is running.

ASSEMBLY AND ADJUSTMENTS

BENCH MOUNTING THE SAW (Fig. 7-8)

Before operating the saw, it must be firmly mounted to a workbench or another rigid frame. Use the base of the saw to mark and pre-drill the mounting holes. If the saw is to be used in one location, permanently secure it to the work surface using wood screws if mounting to wood. Use bolts, washers, and nuts if mounting into metal. To reduce noise and vibration, install a soft foam pad (not supplied) between the scroll saw and the workbench.

Note: mounting hardware not included.



WARNING - to reduce the risk of injury:

- When carrying the saw, hold it close to your body to avoid injury to your back. Bend your knees when lifting the saw.

- Carry the saw by the base. Do not carry the saw by the power cord.

- Secure the saw in a position where people cannot stand, sit, or walk behind it. Debris thrown from the saw could injure people standing, sitting, or walking behind it.

- Secure the saw on a firm, level surface where the saw cannot rock. Make sure there is adequate room for handling and properly supporting the work piece.

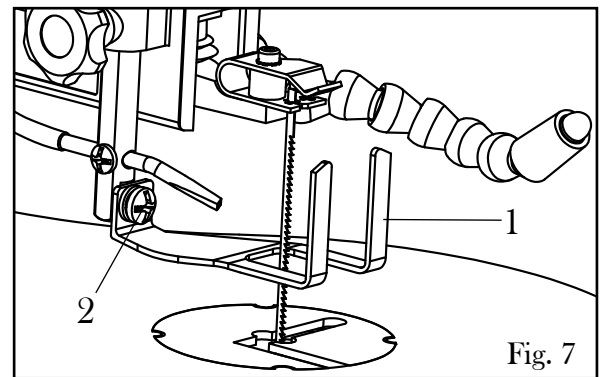

Fig. 7

Blade guard foot adjustment (Fig. 7 and 8)

When cutting at angles, the blade guard foot should be adjusted so it is parallel to the table and rests flat above the work piece.

1. To adjust, loosen the screw (2), tilt the foot (1) so it is parallel to the table, and tighten the screw.

2. Loosen the height adjustment knob (3) to raise or lower the foot until it just rests on top of the work piece. Tighten the knob.

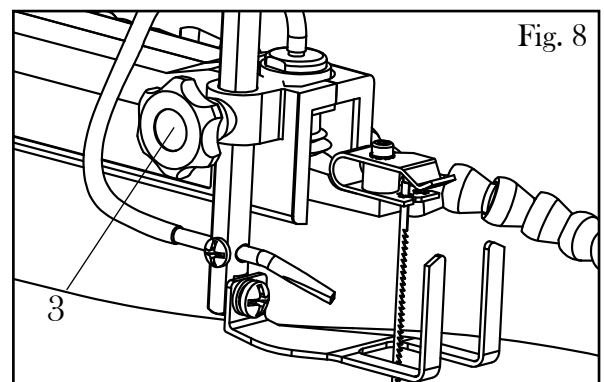
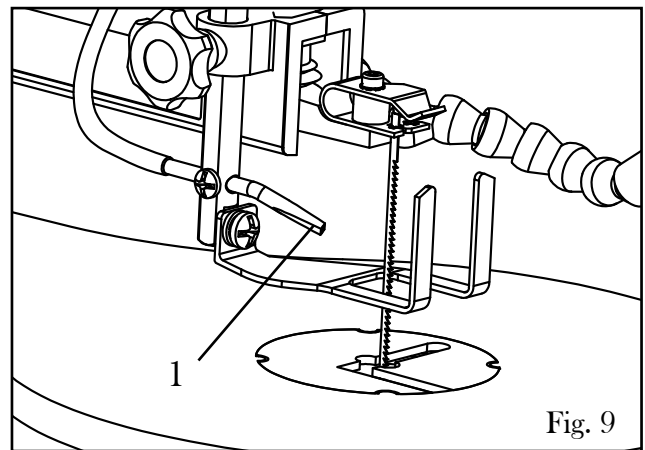

Fig. 8

ASSEMBLY AND ADJUSTMENTS

ADJUSTING THE DUST BLOWER (Fig. 9)

For best results, the dust blower tube (1) should be adjusted to direct air at both the blade and the work piece.



SAWDUST COLLECTION PORT (Fig. 10 and 11)

This scroll saw allows a hose or vacuum accessory (not provided) to be connected to the dust chute (2). If excessive sawdust buildup occurs inside the base, use a wet/dry vacuum cleaner or manually remove sawdust by removing the screws (3) and metal plate on the left side of the saw. Reattach the metal plate and screws before starting the saw. This will keep your saw cutting efficiently.

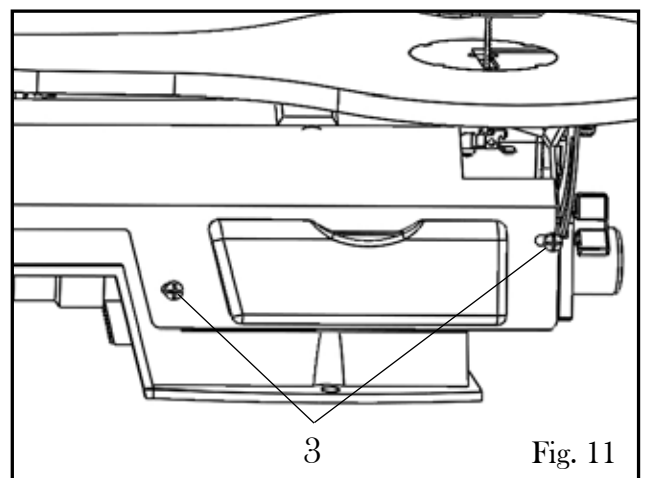
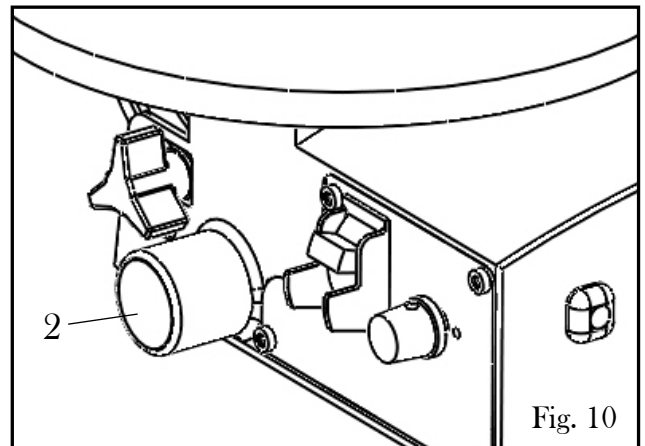

ASSEMBLY AND ADJUSTMENTS

BLADE SELECTION (Fig. 12)

This scroll saw accepts 5" length pin end and pinless blades, with a wide variety of blade thicknesses and widths. The type of material and intricacies of cutting operations will determine the number of teeth per inch. Always select the narrowest blades for intricate curve cutting and the widest blades for straight and large curve cutting operations. The following table represents suggestions for various materials. Use this table as an example, but with practice, personal preference will be the best selection method.

When choosing a blade, use very fine, narrow blades to scroll cut in thin wood 1/4" thick or less.

Use wider blades for thicker materials but this will reduce the ability to cut tight curves. A smaller blade width can cut circles with smaller diameters.

Note: Thinner blades will have more possibilities for blade deflection when cutting angles are not perpendicular to the table.

TEETH PER INCH	BLADE WIDTH	BLADE THICKNESS	BLADE SPM	MATERIAL CUT
10 to 15	.11"	.018"	500 to 1200 SPM	Medium turns on 1/4" to 1-3/4" wood, soft metal, hardwood
15 to 28	.055" to .11"	.01 to .018"	800 to 1700 SPM	Small turns on 1/8" to 1-1/2" wood, soft metal, hardwood

BLADE CARE

To maximize the life of your scroll saw blades:

1. Do not bend blades when installing.
2. Always set proper blade tension.
3. Use the right blade (see instruction on replacement blade packaging for proper use).
4. Feed the work correctly into the blade.
5. Use thin blades for intricate cutting.

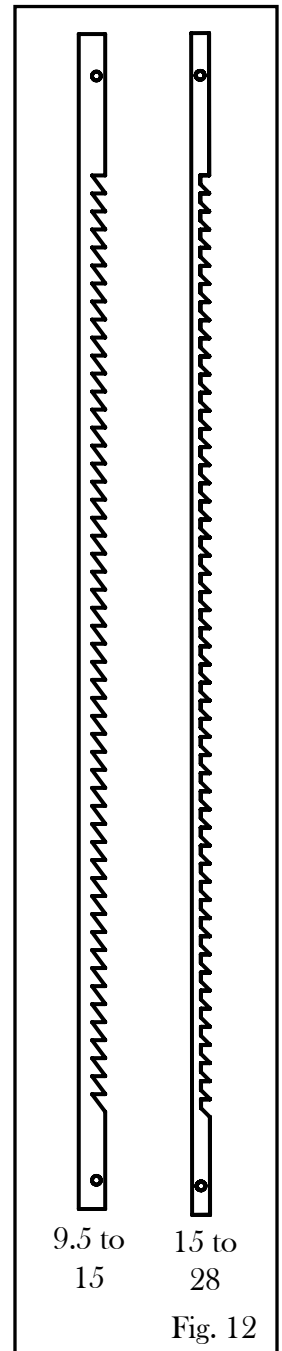

Fig. 12



CAUTION: Any and all servicing should be performed by a qualified service center.

ASSEMBLY AND ADJUSTMENTS

BLADE REMOVAL AND INSTALLATION (Fig. 13 to 15)



WARNING: To prevent personal injury, always turn saw OFF and disconnect the plug from the power source before changing blades or making adjustments.

This saw uses pinned and pinless blades. Pinned blades are thicker for stability and for faster assembly. They provide faster cutting on a variety of materials.

Note: When installing pinned blades, the slot on the blade holder must be slightly wider than the thickness of the blade. After the blade is installed, the blade tension mechanism will keep it in place.

1. To remove the blade, loosen the tension on it by lifting up the blade tension lever. Turn the lever counterclockwise to loosen the blade holder if necessary.

2. Remove the table insert. Carefully pry up on the table insert to remove.

3. Push down on the upper blade holder to remove the blade from the holder (2). Remove the blade from the lower blade holder (3).

CAUTION: Install the blade with the teeth pointing downward.

4. To install the blade, hook the blade in the recess of the lower blade holder (3).

5. While pushing down on the upper blade holder, insert the blade into the slot of the holder.

7. Move the blade tension lever down and make sure the blade pin is properly positioned in the blade holders.

8. Adjust the blade to the desired tension. Turning the blade tension knob clockwise tightens the blade and turning the knob counterclockwise loosens the blade.

8. Place the table insert back into place.

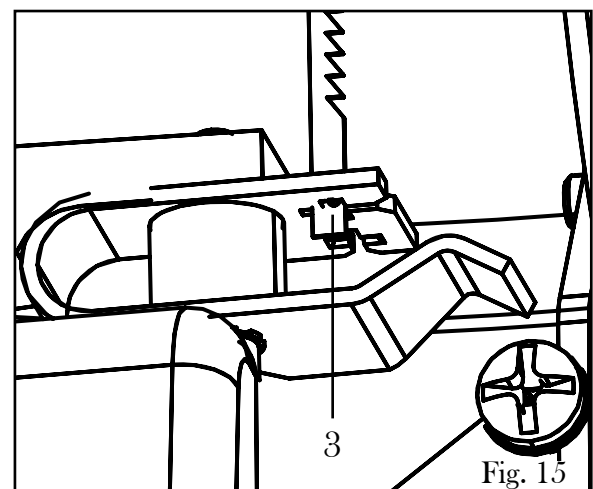
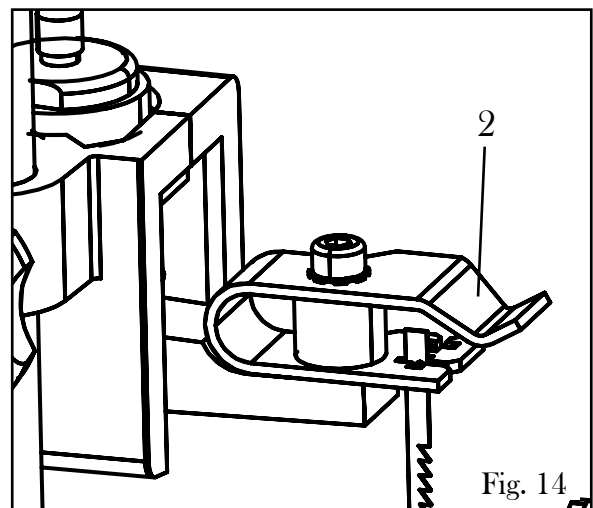
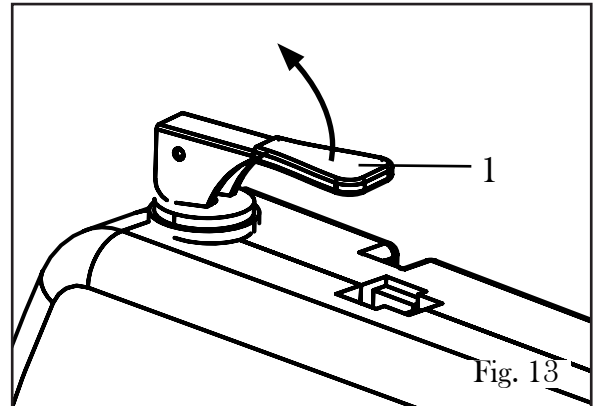

ASSEMBLY AND ADJUSTMENTS

ADJUSTING THE BLADE DIRECTION (Fig. 16 & 17)

The WEN Scroll Saw accepts pinned blades in two different positions to accommodate a wider variety of workpieces. Notice the two various slots for pinned blades that appear on the head of the saw (Fig. 16).

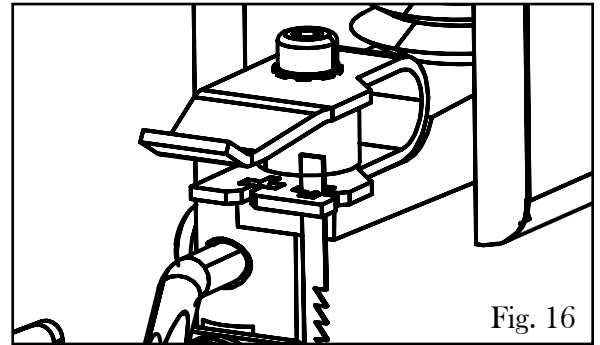

Fig. 16

Pinned blades can be placed in either of the two slots, changing the direction of the blade by 90 degrees. A coinciding slot exists for each holder underneath the plate.

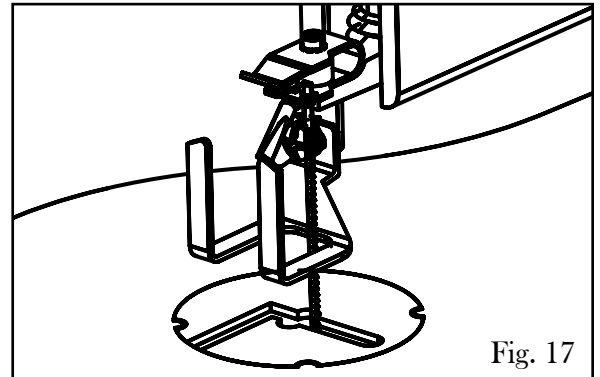

Fig. 17

INSTALLING PINLESS BLADE (Fig. 18 & 19)

1. Remove the existing blade and table insert (see Blade Removal and Installation).

2. To install the pinless blade, loosen the thumb screw on the lower blade attachment.

3. Install the blade into the lower blade attachment and tighten the thumb screw. Hook the lower blade attachment onto the curve of the bottom blade holder found underneath the table (1).

4. Place the insert back into the table after carefully inserting the blade through the table insert slot and the pilot hole of the workpiece.

4. Insert the blade into the upper blade attachment. Tighten the upper thumb screw to secure the blade.

5. Hook the upper blade attachment onto the top curve of the upper blade holder (2).

6. Move the blade tension lever down and make sure the blade attachments are properly secured and tensioned onto the machine.

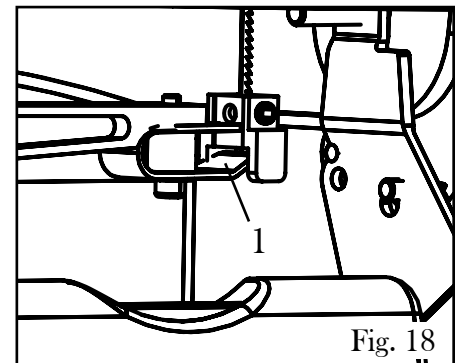
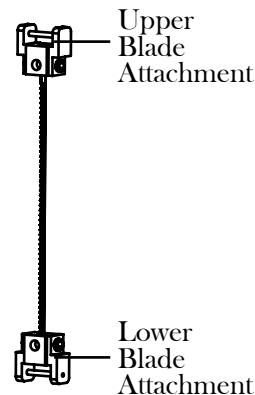

Fig. 18

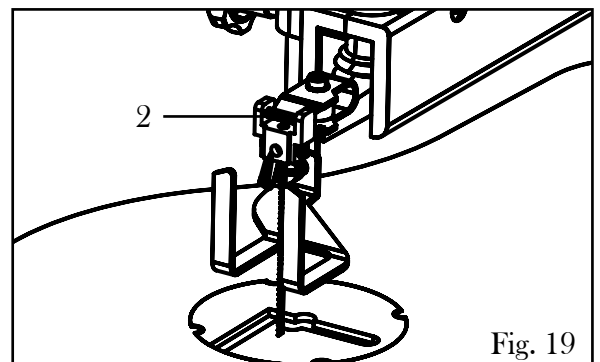

Fig. 19

OPERATION

RECOMMENDATIONS FOR CUTTING

A scroll saw is basically a curve-cutting machine. It can also be used for straight cutting and beveling or angle cutting operations. Please read and understand the following items before attempting to use the saw.

1. When feeding the work piece into the blade do not force it against the blade. This could cause blade deflection. Allow the saw to cut the material by guiding the work piece into the blade as it cuts.
2. The blade teeth cut material **ONLY** on the down stroke.
3. Guide the wood into the blade slowly because the teeth of the blade are very small and remove wood only on the down stroke.
4. There is a learning curve for each person using this saw. During that period of time it is expected that some blades will break until you learn how to use the saw.
5. Best results are achieved when cutting wood one inch thick or less.
6. When cutting wood thicker than one inch, guide the wood slowly into the blade and take extra care not to bend or twist the blade while cutting in order to maximize blade life.
7. Teeth on scroll saw blades wear out and the blades must be replaced frequently for best cutting results. Scroll saw blades generally stay sharp for 1/2 hour to 2 hours of cutting.
8. To get accurate cuts, be prepared to compensate for the blade's tendency to follow the wood grain.
9. This scroll saw is primarily designed to cut wood or wood products. For cutting precious and non-ferrous metals, the variable control switch must be set at very slow speeds.
10. When choosing a blade, use very fine, narrow blades to scroll cut in thin wood 1/4" thick or less. Use wider blades for thicker materials. This, however, will reduce the ability to cut tight curves.
11. Blades wear down faster when cutting plywood or very abrasive particle board. Angle cutting in hardwoods also wears blades down faster.

OPERATION

ON/OFF & SPEED CONTROL SWITCH (Fig. 20)

Always wait for the saw to come to a complete stop before restarting.

1. To turn the saw on, flip the ON/OFF switch to ON (2). When first starting the saw, it is best to move the speed control knob (1) to the middle speed position.
2. Adjust the blade speed to the desired setting between 400 to 1600 strokes per minute (SPM). Turning the control knob clockwise increases speed; turning it counterclockwise reduces speed.
3. To turn the saw off, flip the ON/OFF switch back to OFF (2) in. Note: You can lock the scroll saw by removing the tip of the switch. Just pry off the switch lock with your fingernails to prevent accidental operation.

WARNING: To avoid injury from accidental start-ups, always turn the switch OFF and unplug the scroll saw before moving the tool, replacing the blade, or making adjustments.



FREEHAND CUTTING (Fig. 21)

1. Lay out desired design, or secure design to the work piece.
2. Raise the blade guard foot (1) by loosening the height adjustment knob (2).
3. Position the work piece against the blade and place the blade guard foot against the top surface of the work piece.
4. Secure the blade guard foot (1) by tightening the height adjustment knob (2).
5. Remove the work piece from the blade prior to turning the scroll saw ON.

CAUTION: In order to avoid uncontrollable lifting of the work piece and to reduce blade breakage, do not turn the switch on while the work piece is against the blade.

6. Slowly feed the work piece into the blade by guiding and pressing the work piece down against the table.

CAUTION: Do not force the leading edge of the work piece into the blade. The blade will deflect, reducing accuracy of cut, and may break.

7. When the cut is complete, move the trailing edge of the work piece beyond the blade guard foot. Turn the switch OFF.

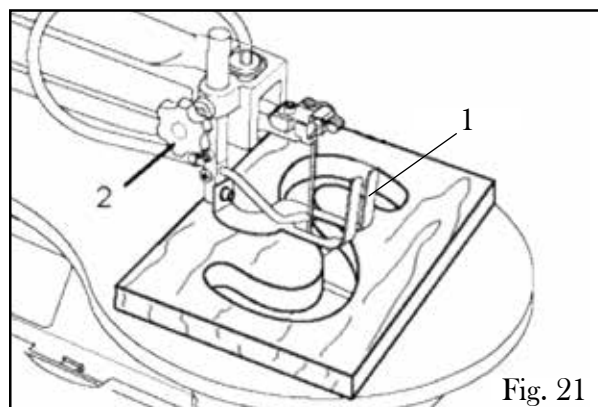
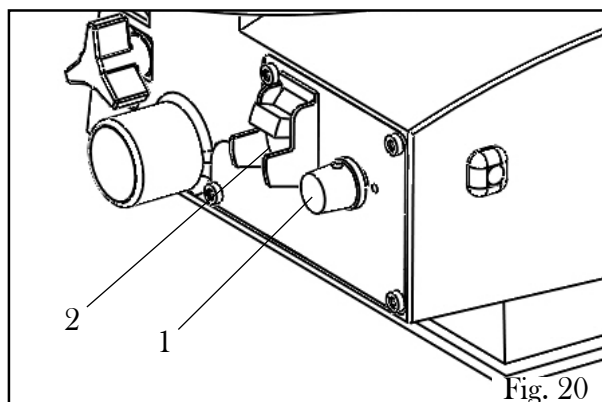

OPERATION

ANGLE CUTTING (BEVELING) (Fig. 22)

1. Layout or secure design to work piece.
2. Move the blade guard foot to the highest position by loosening the height adjustment knob (1). Retighten.
3. Tilt the table to the desired angle by loosening the table bevel lock handle (2). Move the table to the proper angle using the degree scale and the pointer (3).
4. Tighten the table bevel lock handle (2).
5. Loosen the blade guard screw, and tilt the blade guard to the same angle as the table. Retighten the blade guard screw.
6. Position the work piece on the right side of the blade. Lower the blade guard foot against the surface by loosening the height adjustment knob. Retighten.
7. Follow steps 5 to 7 under Freehand cutting.

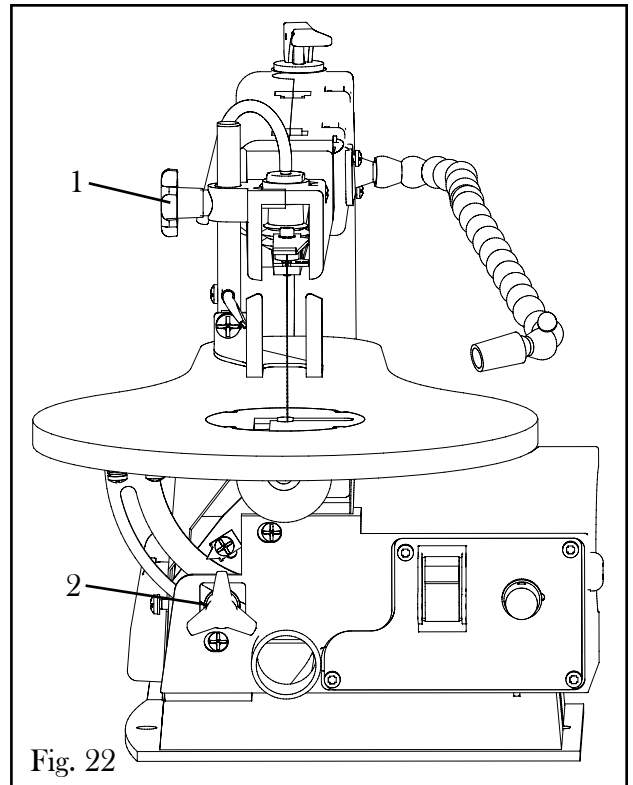

INTERIOR CUTTING (Fig. 23)

1. Lay out the design on the work piece. Drill a 1/4" hole in the work piece.
2. Remove the blade. See Blade removal and installation.
3. Place the work piece on the saw table with the hole in the work piece over the access hole in the table.
4. Install a blade through the hole in the work piece.
5. Follow steps 3-7, under Freehand cutting.
6. When finished making the interior scroll cuts simply turn the scroll saw OFF. Unplug the saw before removing the blade from the blade holder. Remove the work piece from the table.

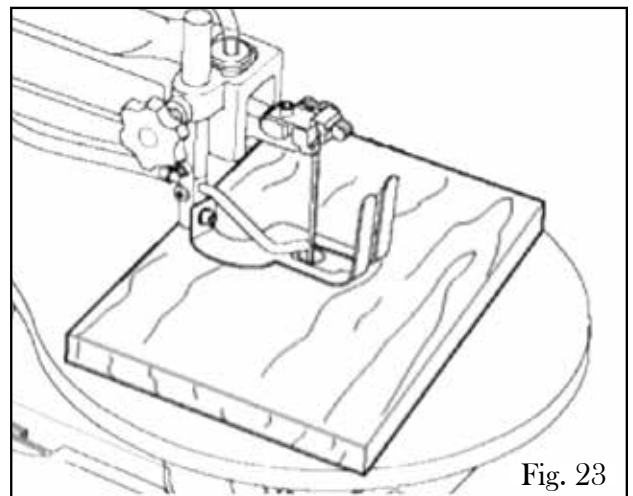

OPERATION

RIP OR STRAIGHT LINE CUTTING (Fig. 24)

1. Raise the blade guard foot (1) by loosening the height adjustment knob (2).
2. Measure from the tip of the blade to the desired distance. Position the straight edge parallel to the blade at that distance.
3. Clamp the straight edge to the table.
4. Recheck your measurements using the work piece to be cut and make sure the straight edge is secure.
5. Position the work piece against the blade and place the blade guard foot against the top surface of the work piece.
6. Secure the blade guard foot in place by tightening the height adjustment knob.
7. Remove the work piece from the blade prior to turning the scroll saw ON.

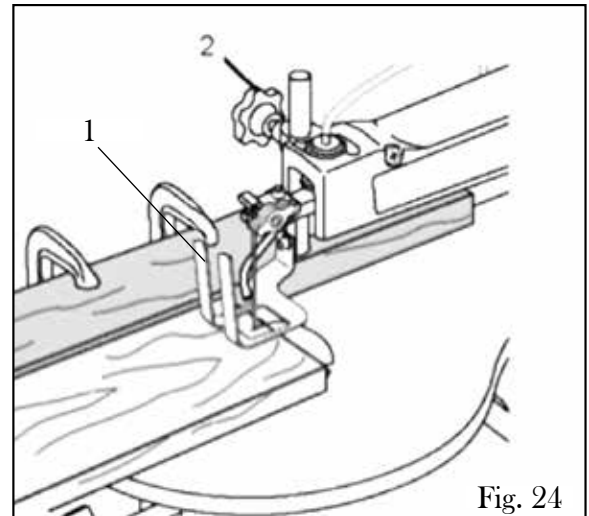

Fig. 24

- CAUTION:** In order to avoid uncontrollable lifting of the work piece and reduce blade breakage, do not turn the switch on while the work piece is against the blade.
8. Position the work piece against the straight edge prior to touching the leading edge of the work piece against the blade.
 9. Slowly feed the work piece into the blade, guiding the work piece against the straight edge and pressing the work piece down against the table.
- CAUTION:** Do not force the leading edge of the work piece into the blade. The blade will deflect, reducing the accuracy of the cut, and may even break.
10. When the cut is complete, move the trailing edge of the work piece beyond the blade guard foot. Turn the switch OFF.

MAINTENANCE

WARNING: Always turn the switch OFF and unplug the power cord from the outlet before maintaining or lubricating the scroll saw.

To ensure that the wood glides smoothly across the work surface, periodically apply a coat of paste wax (sold separately) to the surface of the worktable. If the power cord is worn out or damaged in any way, replace it immediately. Do not attempt to oil the motor bearings or service the motor's internal parts.

LUBRICATION (Fig. 25)

Lubricate the arm bearings after every 50 hours of use.

1. Turn the saw on its side and remove the cover.
2. Squirt a generous amount of SAE 20 oil (lightweight motor oil, sold separately) around the shaft and bearing.
3. Let the oil soak in overnight.
4. Repeat the above procedure for the opposite side of the saw.

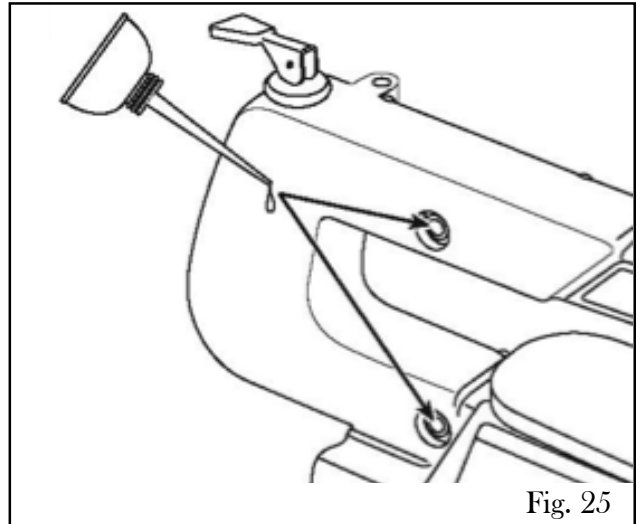

Fig. 25

BLADES

To maximize the life of your scroll saw blades:

1. Do not bend blades when installing.
2. Always set proper blade tension.
3. Use the right blade (see instructions on replacement blade packaging for proper use).
4. Feed the work correctly into the blade.
5. Use thin blades for intricate cutting.

CAUTION: Any and all servicing should be performed by a qualified service center.

EXPLODED VIEW & PARTS LIST

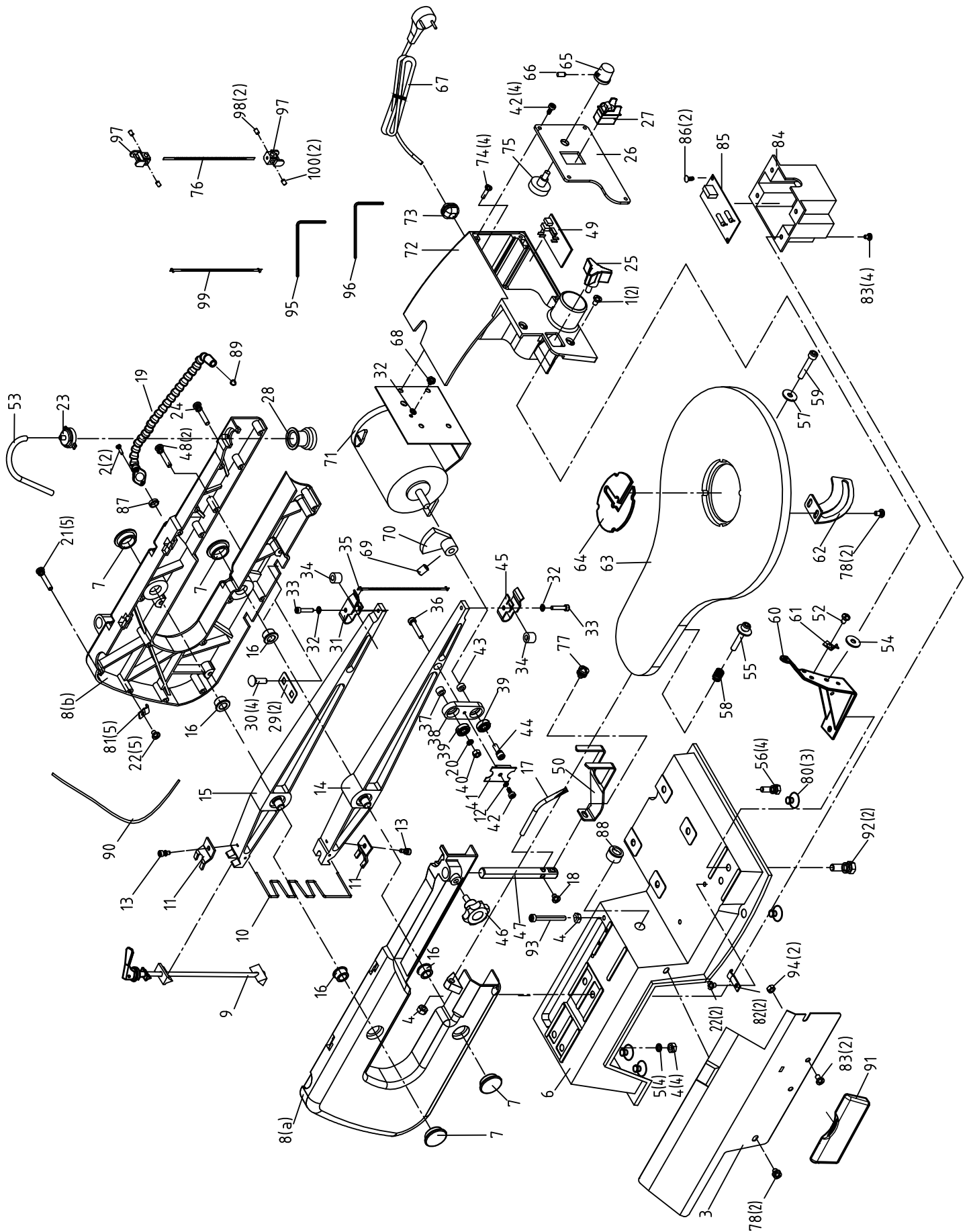

EXPLODED VIEW & PARTS LIST (3920C)

Item	Stock #	Description
1	3920B-001	Screw M5x8
2	3920B-002	Screw ST4.2x10
3	3920B-003	Side Cover
4	3920B-004	Nut M6
5	3920B-005	Spring Washer M6
6	3920B-006	Base
7	3920B-007	Oil Cap
8A	3920C-008A	Left Arm Housing
8B	3920C-008B	Right Arm Housing
9	3920B-009	Tension Bolt Assembly
10	3920B-010	Extension Spring
11	3920B-011	Pressure Plate
12	3920B-012	Spring Washer M4
13	3920B-013	Screw M4X10
14	3920C-013	Lower Arm
15	3920C-014	Upper Arm
16	3920C-015	Arm Bearing
17	3920C-016	Blast Pipe
18	3920B-018	Screw M5x6
19	3920B-019	Light Assembly
20	3920B-020	Spring Washer M5
21	3920B-021	Screw M5x35
22	3920B-022	Screw M4x6
23	3920B-023	Bellows Cap
24	3920B-024	Screw M5x28
25	3920B-025	Table Lock Knob
26	3920B-026	Switch Fixing Board
27	3920B-027	Switch
28	3920B-028	Bellows
29	3920B-029	Fixing Plate
30	3920B-030	Bolt M6x20
31	3920C-030	Upper Blade Support
32	3920B-032	Washer M4
33	3920B-033	Screw M4x20
34	3920C-034	Support Cushion
35	3920B-076	Blade 15TPI
36	3920B-036	Screw M5x25
37	3920B-037	Big Cushion
38	3920B-038	Eccentricity Connector
39	3920B-039	Bearing 625Z (80025)
40	3920B-040	Nut M5
41	3920B-041	Clamping Board
42	3920B-042	Screw ST4.2x9.5
43	3920B-043	Washer
44	3920B-044	Screw M5x16
45	3920C-044	Lower Blade Support
46	3920B-046	Drop Foot Lock Knob
47	3920B-047	Drop Foot Fixing Pole
48	3920B-048	Screw M5x30

49	3920B-049	PCB
50	3920B-050	Drop Foot
52	3920B-052	Screw M6x10
53	3920B-053	PVC Pipe
54	3920B-054	Big Washer M6
55	3920B-055	Screw M6x40
56	3920B-056	Bolt M6x16
57	3920B-057	Washer M6
58	3920B-058	Spring
59	3920B-059	Screw M6x25
60	3920B-060	Work Table Bracket
61	3920B-061	Pointer
62	3920B-062	Bevel Scale
63	3920B-063	Work Table
64	3920B-064	Work Table Insert
65	3920B-065	Speed Adjusting Knob
66	3920B-066	Screw M5x6
67	3920B-067	Power Cord
68	3920B-068	Screw M4x8
69	3920B-069	Screw M8x12
70	3920B-070	Eccentric Wheel
71	3920B-071	Motor
72	3920B-072	Switch Box
73	3920B-073	Cord Clamp
74	3920B-074	Screw
75	3920B-075	Potentiometer
76	3920B-076-2	Blade 18TPI Pinless
77	3920B-077	Screw M4x10
78	3920B-078	Screw M6x10
80	3920B-080	Foot
81	3920B-081	Wire Clip 1
82	3920B-082	Wire Clip 2
83	3920B-083	Screw M4x8
84	3920B-084	Transformer Box
85	3920B-085	Circuit board
86	3920B-086	Screw ST2.9x6.5
87	3920B-087	Cord Bushing 1
88	3920B-088	Cord Bushing 2
89	3920B-019	LED Assembly
91	3920B-091	Tool Box
92	3920B-092	Bolt M8x20
93	3920B-093	Bolt M6x80
94	3920B-094	Nut M4
95	3920C-095	Wrench S3
96	3920C-096	Wrench S2.5
97	3920C-097	Blade Adaptor
98	3920C-098	Set Screw M5x8
99	3920B-076-1	Blade 18TPI Pinned
100	3920C-100	Adaptor Location Screw

LIMITED TWO YEAR WARRANTY

WEN Products is committed to building tools that are dependable for years. Our warranties are consistent with this commitment and our dedication to quality.

LIMITED WARRANTY OF WEN CONSUMER POWER TOOLS PRODUCTS FOR HOME USE

GREAT LAKES TECHNOLOGIES, LLC (“Seller”) warrants to the original purchaser only, that all WEN consumer power tools will be free from defects in material or workmanship for a period of two (2) years from date of purchase. Ninety days for all WEN products, if the tool is used for professional use.

SELLER’S SOLE OBLIGATION AND YOUR EXCLUSIVE REMEDY under this Limited Warranty and, to the extent permitted by law, any warranty or condition implied by law, shall be the repair or replacement of parts, without charge, which are defective in material or workmanship and which have not been misused, carelessly handled, or misrepaired by persons other than Seller or Authorized Service Center. To make a claim under this Limited Warranty, you must make sure to keep a copy of your proof of purchase that clearly defines the Date of Purchase (month and year) and the Place of Purchase. Place of purchase must be a direct vendor of Great Lakes Technologies, LLC. Third party vendors such as garage sales, pawn shops, resale shops, or any other secondhand merchant void the warranty included with this product. Contact techsupport@wenproducts.com or 1-800-232-1195 to make arrangements for repairs and transportation.

When returning a product for warranty service, the shipping charges must be prepaid by the purchaser. The product must be shipped in its original container (or an equivalent), properly packed to withstand the hazards of shipment. The product must be fully insured with a copy of the warranty card and/or the proof of purchase enclosed. There must also be a description of the problem in order to help our repairs department diagnose and fix the issue. Repairs will be made and the product will be returned and shipped back to the purchaser at no charge.

THIS LIMITED WARRANTY DOES NOT APPLY TO ACCESSORY ITEMS THAT WEAR OUT FROM REGULAR USAGE OVER TIME INCLUDING BELTS, BRUSHES, BLADES, ETC.

ANY IMPLIED WARRANTIES SHALL BE LIMITED IN DURATION TO TWO (2) YEARS FROM DATE OF PURCHASE. SOME STATES IN THE U.S., SOME CANADIAN PROVINCES DO NOT ALLOW LIMITATIONS ON HOW LONG AN IMPLIED WARRANTY LASTS, SO THE ABOVE LIMITATION MAY NOT APPLY TO YOU.

IN NO EVENT SHALL SELLER BE LIABLE FOR ANY INCIDENTAL OR CONSEQUENTIAL DAMAGES (INCLUDING BUT NOT LIMITED TO LIABILITY FOR LOSS OF PROFITS) ARISING FROM THE SALE OR USE OF THIS PRODUCT. SOME STATES IN THE U.S. AND SOME CANADIAN PROVINCES DO NOT ALLOW THE EXCLUSION OR LIMITATION OF INCIDENTAL OR CONSEQUENTIAL DAMAGES, SO THE ABOVE LIMITATION OR EXCLUSION MAY NOT APPLY TO YOU.

THIS LIMITED WARRANTY GIVES YOU SPECIFIC LEGAL RIGHTS, AND YOU MAY ALSO HAVE OTHER RIGHTS WHICH VARY FROM STATE TO STATE IN THE U.S., PROVINCE TO PROVINCE IN CANADA AND FROM COUNTRY TO COUNTRY.

THIS LIMITED WARRANTY APPLIES ONLY TO PORTABLE ELECTRIC TOOLS, BENCH POWER TOOLS, OUTDOOR POWER EQUIPMENT AND PNEUMATIC TOOLS SOLD WITHIN THE UNITED STATES OF AMERICA, CANADA AND THE COMMONWEALTH OF PUERTO RICO. FOR WARRANTY COVERAGE WITHIN OTHER COUNTRIES, CONTACT THE WEN CUSTOMER SUPPORT LINE.