

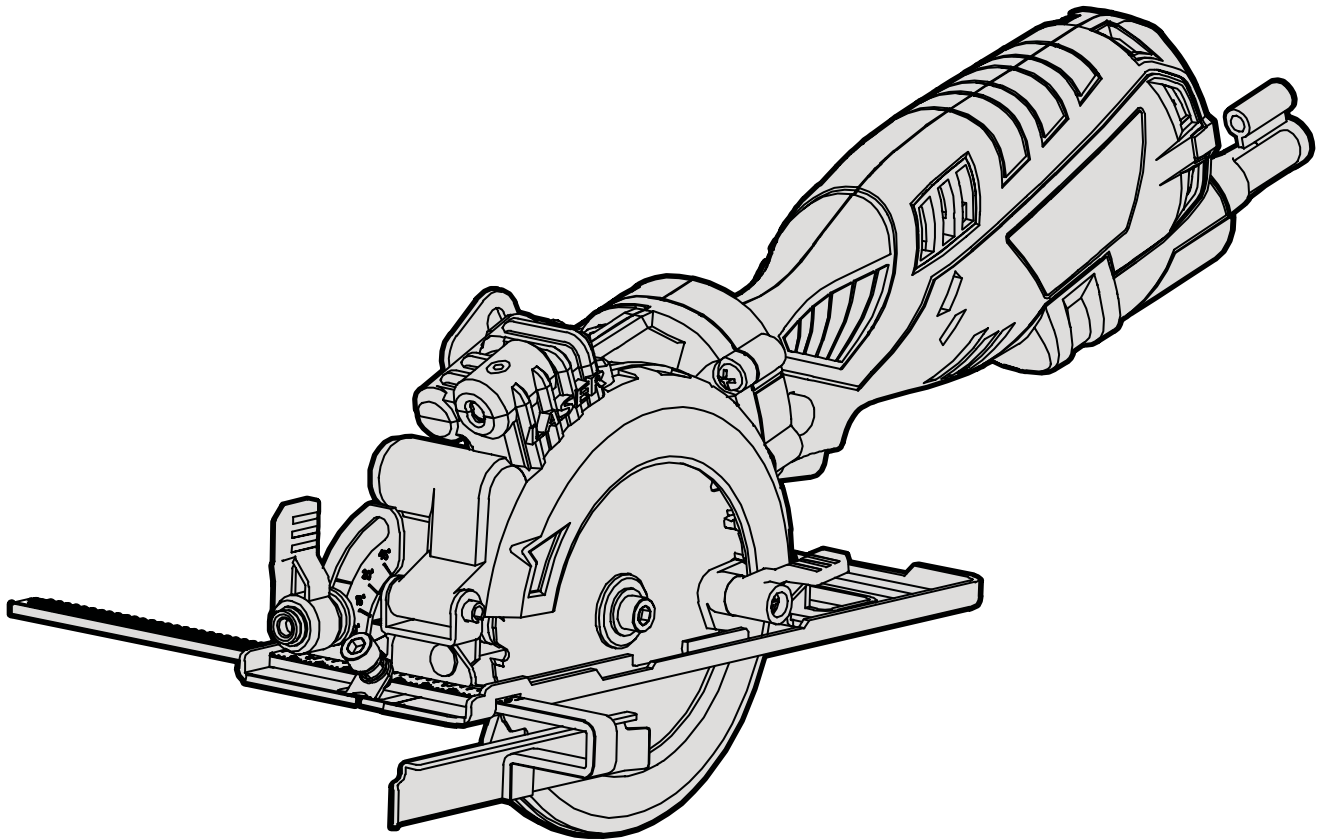

MODEL 3625

4.5-INCH COMPACT CIRCULAR SAW

Instruction Manual



NEED HELP? CONTACT US!

Have product questions? Need technical support? Please feel free to contact us:



1-847-429-9263 (M-F 8AM-5PM CST)



TECHSUPPORT@WENPRODUCTS.COM

IMPORTANT: Your new tool has been engineered and manufactured to WEN's highest standards for dependability, ease of operation, and operator safety. When properly cared for, this product will supply you years of rugged, trouble-free performance. Pay close attention to the rules for safe operation, warnings, and cautions. If you use your tool properly and for its intended purpose, you will enjoy years of safe, reliable service.

For replacement parts and the most up-to-date instruction manuals, visit ***WENPRODUCTS.COM***

CONTENTS

WELCOME	3
Introduction	3
Specifications.....	3
SAFETY	4
General Safety Rules	4
Circular Saw Safety Warnings.....	6
Electrical Information	9
BEFORE OPERATING	10
Unpacking & Packing List	10
Know Your Circular Saw.....	11
Assembly & Adjustments.....	11
OPERATION & MAINTENANCE	15
Operation	15
Maintenance.....	17
Exploded View & Parts List.....	19
Warranty Statement	22

To purchase accessories and replacement parts for your tool, visit ***WENPRODUCTS.COM***

Replacement Wood-Cutting Blades (Model BL11510W)

INTRODUCTION

Thanks for purchasing the WEN Circular Saw. We know you are excited to put your tool to work, but first, please take a moment to read through the manual. Safe operation of this tool requires that you read and understand this operator's manual and all the labels affixed to the tool. This manual provides information regarding potential safety concerns, as well as helpful assembly and operating instructions for your tool.

 Indicates danger, warning, or caution. The safety symbols and the explanations with them deserve your careful attention and understanding. Always follow the safety precautions to reduce the risk of fire, electric shock or personal injury. However, please note that these instructions and warnings are not substitutes for proper accident prevention measures.

NOTE: The following safety information is not meant to cover all possible conditions and situations that may occur. WEN reserves the right to change this product and specifications at any time without prior notice.

At WEN, we are continuously improving our products. If you find that your tool does not exactly match this manual, please visit wenproducts.com for the most up-to-date manual or contact our customer service at **1-847-429-9263**.

Keep this manual available to all users during the entire life of the tool and review it frequently to maximize safety for both yourself and others.

SPECIFICATIONS

Model Number	3625	
Motor	120V AC, 60 Hz, 5A	
Motor Speed (No-Load)	3500 RPM	
Blade Diameter	4-1/2 in. (115mm)	
Arbor Size	3/8 in. (10mm)	
Maximum Cutting Depth	90°	1-11/16 in. (43mm)
	45°	1-1/8 in. (28mm)
Blade Body Thickness	1.2mm	
Blade Teeth Thickness	1.8mm	
Laser Battery Type	LR44	
Laser Power	0.278 mW	
Laser	Class II, 650 nm	
Dust Tube Outer Diameter	1.35 in. to 1.5 in.	
Base Plate Dimensions	9.5 in. x 3.4 in. x 0.079 in.	
Product Dimensions	16.2 in. x 4.3 in. x 4.3 in.	
Product Weight	5.8 lbs	

GENERAL SAFETY RULES

 **WARNING!** Read all safety warnings and all instructions. Failure to follow the warnings and instructions may result in electric shock, fire and/or serious injury.

Safety is a combination of common sense, staying alert and knowing how your item works. The term “power tool” in the warnings refers to your mains-operated (corded) power tool or battery-operated (cordless) power tool.

SAVE THESE SAFETY INSTRUCTIONS.

WORK AREA SAFETY

- 1. Keep work area clean and well lit.** Cluttered or dark areas invite accidents.
- 2. Do not operate power tools in explosive atmospheres, such as in the presence of flammable liquids, gases or dust.** Power tools create sparks which may ignite the dust or fumes.
- 3. Keep children and bystanders away while operating a power tool.** Distractions can cause you to lose control.

ELECTRICAL SAFETY

- 1. Power tool plugs must match the outlet. Never modify the plug in any way. Do not use any adapter plugs with earthed (grounded) power tools.** Unmodified plugs and matching outlets will reduce risk of electric shock.
- 2. Avoid body contact with earthed or grounded surfaces such as pipes, radiators, ranges and refrigerators.** There is an increased risk of electric shock if your body is earthed or grounded.
- 3. Do not expose power tools to rain or wet conditions.** Water entering a power tool will increase the risk of electric shock.
- 4. Do not abuse the cord. Never use the cord for carrying, pulling or unplugging the power tool. Keep cord away from heat, oil, sharp edges or moving parts.** Damaged or entangled cords increase the risk of electric shock.
- 5. When operating a power tool outdoors, use an extension cord suitable for outdoor use.** Use of a cord suitable for outdoor use reduces the risk of electric shock.

- 6. If operating a power tool in a damp location is unavoidable, use a ground fault circuit interrupter (GFCI) protected supply.** Use of a GFCI reduces the risk of electric shock.

PERSONAL SAFETY

- 1. Stay alert, watch what you are doing and use common sense when operating a power tool. Do not use a power tool while you are tired or under the influence of drugs, alcohol or medication.** A moment of inattention while operating power tools may result in serious personal injury.
- 2. Use personal protective equipment. Always wear eye protection.** Protective equipment such as a respiratory mask, non-skid safety shoes and hearing protection used for appropriate conditions will reduce the risk of personal injury.
- 3. Prevent unintentional starting. Ensure the switch is in the off-position before connecting to power source and/or battery pack, picking up or carrying the tool.** Carrying power tools with your finger on the switch or energizing power tools that have the switch on invites accidents.
- 4. Remove any adjusting key or wrench before turning the power tool on.** A wrench or a key left attached to a rotating part of the power tool may result in personal injury.
- 5. Do not overreach. Keep proper footing and balance at all times.** This enables better control of the power tool in unexpected situations.
- 6. Dress properly. Do not wear loose clothing or jewelry. Keep your hair and clothing away from moving parts.** Loose clothes, jewelry or long hair can be caught in moving parts.

GENERAL SAFETY RULES

 **WARNING!** Read all safety warnings and all instructions. Failure to follow the warnings and instructions may result in electric shock, fire and/or serious injury.

Safety is a combination of common sense, staying alert and knowing how your item works. The term “power tool” in the warnings refers to your mains-operated (corded) power tool or battery-operated (cordless) power tool.

SAVE THESE SAFETY INSTRUCTIONS.

7. If devices are provided for the connection of dust extraction and collection facilities, ensure these are connected and properly used. Use of dust collection can reduce dust-related hazards.

POWER TOOL USE AND CARE

1. Do not force the power tool. Use the correct power tool for your application. The correct power tool will do the job better and safer at the rate for which it was designed.

2. Do not use the power tool if the switch does not turn it on and off. Any power tool that cannot be controlled with the switch is dangerous and must be repaired.

3. Disconnect the plug from the power source and/or the battery pack from the power tool before making any adjustments, changing accessories, or storing power tools. Such preventive safety measures reduce the risk of starting the power tool accidentally.

4. Store idle power tools out of the reach of children and do not allow persons unfamiliar with the power tool or these instructions to operate the power tool. Power tools are dangerous in the hands of untrained users.

5. Maintain power tools. Check for misalignment or binding of moving parts, breakage of parts and any other condition that may affect the power tool's operation. If damaged, have the power tool repaired before use. Many accidents are caused by poorly maintained power tools.

6. Keep cutting tools sharp and clean. Properly maintained cutting tools with sharp cutting edges are less likely to bind and are easier to control.

7. Use the power tool, accessories and tool bits, etc. in accordance with these instructions, taking into account the working conditions and the work to be performed. Use of the power tool for operations different from those intended could result in a hazardous situation.

8. Use clamps to secure your workpiece to a stable surface. Holding a workpiece by hand or using your body to support it may lead to loss of control.

9. KEEP GUARDS IN PLACE and in working order.

SERVICE

1. Have your power tool serviced by a qualified repair person using only identical replacement parts. This will ensure that the safety of the power tool is maintained.

CALIFORNIA PROPOSITION 65 WARNING

Some dust created by power sanding, sawing, grinding, drilling, and other construction activities may contain chemicals, including lead, known to the State of California to cause cancer, birth defects, or other reproductive harm. Wash hands after handling. Some examples of these chemicals are:

- Lead from lead-based paints.
- Crystalline silica from bricks, cement, and other masonry products.
- Arsenic and chromium from chemically treated lumber.

Your risk from these exposures varies depending on how often you do this type of work. To reduce your exposure to these chemicals, work in a well-ventilated area with approved safety equipment such as dust masks specially designed to filter out microscopic particles.

CIRCULAR SAW SAFETY WARNINGS

 **WARNING!** Do not operate the power tool until you have read and understood the following instructions and the warning labels.

CIRCULAR SAW SAFETY

1. **TOOL PURPOSE.** This circular saw is designed to cut through softwood, tile, and aluminum only. Cutting other materials could result in fire, injury, or damage to the workpiece. Using the machine for any other purpose for which it is not designed may result in serious injuries, machine damage and voiding of the warranty.

2. Check the base plate for proper movement before each use. Press the blade release button to make sure the base plate can move freely and does not touch the blade or any other parts. Do not operate the saw if the base plate does not move or does not open and close smoothly. Dropping the saw may cause the base plate to not work properly.

3. PERSONAL SAFETY.

- Always wear ANSI Z87.1-approved glasses with side shields, hearing protection and a dust mask.
- Do not wear loose clothing or jewelry, as they might get drawn in by the tool. Tie back long hair.
- DO NOT wear gloves while operating this machine.

4. **ELECTRIC CORDS.** Keep cords away from heat, oil, sharp edges, and moving parts of the tool. Have an electrician replace or repair damaged or worn cords immediately.

5. **TOOL INSPECTION.** Before operation, check the tool for any damaged or missing parts. Do not use the tool if any part is missing or damaged. Do not use the tool if the power switch is faulty, the plug or cable is damaged, or the tool produces sparks, smoke, or unpleasant odors (you may smell brushes wearing down for a few minutes as the tool breaks in during the first use, that is normal). Make sure all adjustments are correct and all connections are tight.

6. **SECURING THE WORKPIECE.** Use clamps to secure the workpiece whenever possible to prevent wobble, damage to the workpiece, and personal injury. Never hold a piece being cut in your hands or across your legs. It is important to support the work properly to minimize body exposure, blade binding, or loss of control.

7. **STANDING POSITION.** Keep your body positioned to either side of the saw blade, but not in line with cutting path. Kickback could cause the saw to jump backwards.

8. **STARTING THE TOOL.** Always start the saw before the blade is in contact with the workpiece. Let the blade reach full speed before using the tool. The reaction to the torque as the motor accelerates to full speed may cause the tool to kick back.

9. **KEEP HANDS AWAY.** Keep hands away from the cutting area and the blade. Do not reach underneath the workpiece. The blade guard cannot protect you from the blade protruding from the underside of the workpiece. Do not attempt to remove cut material when the blade is moving.

10. **DURING OPERATION.** Do not apply excessive pressure to the tool. Overstressing the tool may cause kickback and damage the tool and accessories. Use special care when working corners, sharp edges etc.

CIRCULAR SAW SAFETY WARNINGS

 **WARNING!** Do not operate the power tool until you have read and understood the following instructions and the warning labels.

CIRCULAR SAW SAFETY

11. **TURNING OFF THE TOOL.** The blade coasts after the saw is turned off. Wait until the blade comes to a full stop before reaching for loose materials or setting the tool down.

12. **REPLACING THE SAW BLADE.** Check the blade for chipped or broken teeth. Do not use dull or damaged blades. Unshaped or improperly set blades produce narrow kerf, causing excessive friction, blade binding, and kickback. Always use blades with correct size and arbor holes. Blades that do not match the mounting hardware of the saw will run eccentrically, causing a loss of control.

13. **MAKING ADJUSTMENTS.** Always turn off and unplug the saw before making adjustments or changing attachments. Accidental start-ups may occur if the saw is plugged in during an accessory change. Develop a periodic maintenance schedule for your tool. Always make sure the power switch is in the OFF position and the machine is unplugged when doing any cleaning, assembly, setup operations, or when not in use.

14. **REPLACEMENTS.** Should any component of your saw be missing/damaged or fail in any way, shut off the switch and remove the plug from power supply outlet. Replace the missing, damaged, or failed parts using only identical replacement parts before resuming operation.

REDUCING KICKBACK

Kickback is a sudden reaction to a pinched, bound or misaligned saw blade, causing an uncontrolled saw to lift up and out of the work piece toward the operator. When the blade is pinched or bound tightly by the kerf closing down, the blade stalls and the motor reaction drives the unit rapidly back toward the operator. If the blade becomes twisted or misaligned in the cut, the teeth at the back edge of the blade can dig into the top surface of the wood causing the blade to climb out of the kerf and jump back towards the operator. Take the proper precautions below to reduce the risk of kickback.

- Maintain a firm grip on the saw and position your body and arm in a way that allows you to resist kickback forces. Kickback forces can be controlled by the operator, if proper precautions are taken.

- When a blade is binding (or when interrupting a cut for any reason), release the trigger and hold the saw motionless in the material until the blade comes to a complete stop. Never attempt to remove the saw from the work or pull the saw backward while the blade is in motion or kickback may occur.

- When restarting a saw in the workpiece, center the blade in the kerf and check that the teeth are not engaged into the material. If the saw blade is binding, it may walk up or kickback from the work piece as the saw is restarted. Investigate and take corrective actions to eliminate the causes of blade binding.

- Support large workpieces to minimize the risk of blade pinching and kickback. Large panels and boards tend to sag under their own weight. Supports must be placed under the panel or board on both sides, near the edge of the panel or board.

- Do not use dull or damaged blades. Unshaped or improperly set blades produce narrow kerf, causing excessive friction, blade binding, and kickback.

- Blade depth and bevel adjusting locking levers must be tight and secure before making a cut. If the blade adjustment shifts while cutting, it will cause binding and kickback.

These safety instructions can't possibly warn of every scenario that may arise with this tool, so always make sure to stay alert and use common sense during operation.

CIRCULAR SAW SAFETY WARNINGS

 **WARNING!** Do not operate the power tool until you have read and understood the following instructions and the warning labels.

LASER SAFETY

ATTENTION! LASER RADIATION. CLASS 2 LASER. DO NOT STARE INTO THE BEAM.

1. Do not look directly into the laser beam with unprotected eyes. Never look into the path of the beam.
2. Never point the laser beam towards reflective surfaces. Never point the laser towards people or animals. Even a laser beam with a low output can cause damage to the eyes.
3. Never open the laser module as unexpected exposure to the beam can occur. The laser cannot be replaced with a different type of laser.
4. Repairs of the laser may only be carried out by the laser manufacturer or an authorized representative.

BATTERY SAFETY

1. Do not short-circuit batteries. Keep the batteries away from metal objects when not in use.
2. Do not charge non-rechargeable batteries.
3. Do not mix old and new batteries or batteries of different types. Replace an entire set of batteries at the same time.
4. Do not keep batteries near fire, ovens or other sources of heat. Do not use batteries in direct sunlight.
5. Remove batteries from the equipment when it will not be used for an extended period of time.
6. Never handle batteries that have leaked without appropriate protection. If the leaked fluid comes into contact with your skin, the skin in this area should be rinsed off under running water immediately. Always prevent the fluid from coming into contact with the eyes and mouth. In the event of contact, please seek immediate medical attention.
7. Do not dismantle batteries. Dispose of used batteries properly at your local collection/recycling facility.

ELECTRICAL INFORMATION

DOUBLE-INSULATED TOOL

The tool's electrical system is double-insulated where two systems of insulation are provided. This eliminates the need for the usual three-wire grounded power cord. Double-insulated tools do not need to be grounded, nor should a means for grounding be added to the product. All exposed metal parts are isolated from the internal metal components with protecting insulation.

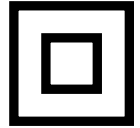

IMPORTANT: Servicing a double-insulated product requires extreme care and knowledge of the system, and should be done only by qualified service personnel using identical replacement parts. Always use original factory replacement parts when servicing.

1. Polarized Plugs. To reduce the risk of electric shock, this equipment has a polarized plug (one blade is wider than the other). This plug will fit in a polarized outlet only one way. If the plug does not fit fully in the outlet, reverse the plug. If it still does not fit, contact a qualified electrician to install a proper outlet. Do not modify the machine plug or the extension cord in any way.

2. Ground fault circuit interrupter protection (GFCI) should be provided on the circuit or outlet used for this power tool to reduce the risk of electric shock.

3. Service and repair. To avoid danger, electrical appliances must only be repaired by a qualified service technician using original replacement parts.

GUIDELINES AND RECOMMENDATIONS FOR EXTENSION CORDS

When using an extension cord, be sure to use one heavy enough to carry the current your product will draw. An undersized cord will cause a drop in line voltage, resulting in loss of power and overheating. The table below shows the correct size to be used according to cord length and ampere rating. When in doubt, use a heavier cord. The smaller the gauge number, the heavier the cord.

AMPERAGE	REQUIRED GAUGE FOR EXTENSION CORDS			
	25 ft.	50 ft.	100 ft.	150 ft.
5A	18 gauge	16 gauge	16 gauge	14 gauge

1. Examine extension cord before use. Make sure your extension cord is properly wired and in good condition. Always replace a damaged extension cord or have it repaired by a qualified person before using it.

2. Do not abuse extension cord. Do not pull on cord to disconnect from receptacle; always disconnect by pulling on plug. Disconnect the extension cord from the receptacle before disconnecting the product from the extension cord. Protect your extension cords from sharp objects, excessive heat and damp/wet areas.

3. Use a separate electrical circuit for your tool. This circuit must not be less than a 12-gauge wire and should be protected with a 15A time-delayed fuse. Before connecting the motor to the power line, make sure the switch is in the OFF position and the electric current is rated the same as the current stamped on the motor nameplate. Running at a lower voltage will damage the motor.

UNPACKING & PACKING LIST

UNPACKING

Carefully remove the circular saw from the packaging and place it on a sturdy, flat surface. Make sure to take out all contents and accessories. Do not discard the packaging until everything is removed. Check the packing list below to make sure you have all of the parts and accessories. If any part is missing or broken, please contact customer service at **1-847-429-9263** (M-F 8-5 CST), or email techsupport@wenproducts.com.

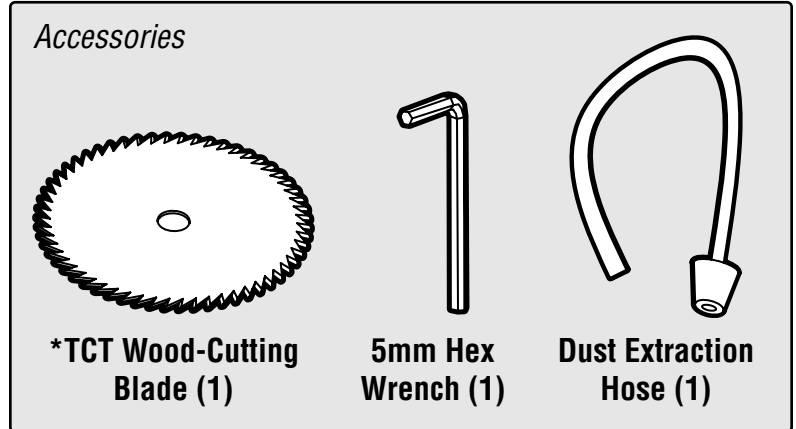
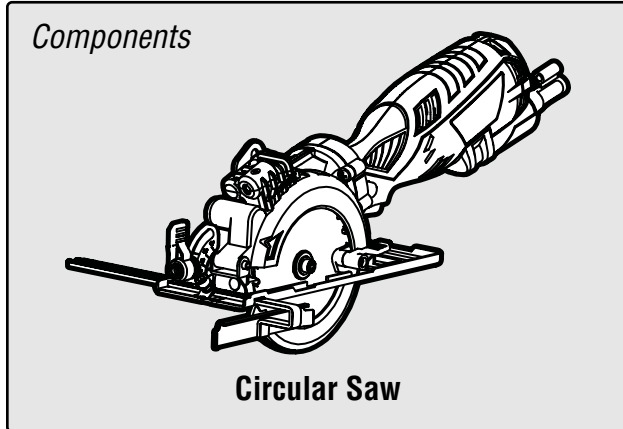

* Pre-Installed

KNOW YOUR CIRCULAR SAW

TOOL PURPOSE

Easily make miter cuts and rough cuts on large sheets of material with your WEN Circular Saw. Refer to the following diagrams to become familiarized with all the parts and controls of your circular saw. The components will be referred to later in the manual for assembly and operation instructions.

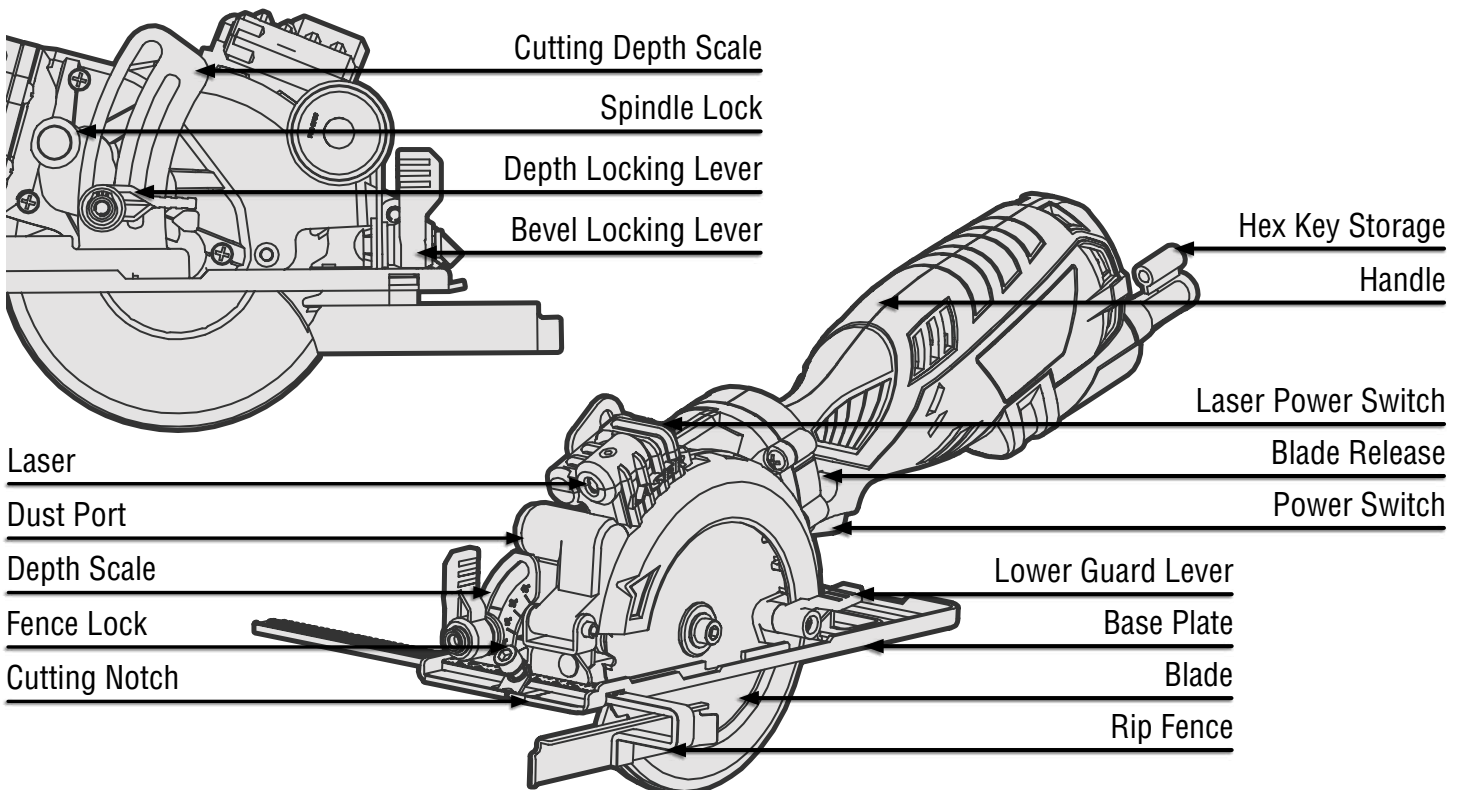

ASSEMBLY & ADJUSTMENTS

⚠ WARNING! To avoid injury from accidental startups, be sure that the tool is switched off and disconnected from the power supply before inspecting the unit, making adjustments, or changing accessories.

INSTALLING/REPLACING THE SAW BLADE

Use saw blades with 4-1/2 inch (115 mm) diameter and 3/8 inch (10 mm) arbor. Do not use a blade that does not match the diameter or arbor size. The pre-installed blade has a body that is 1.2 mm thick and teeth that are 1.8 mm thick. Do not use a blade that is thicker than the included blades, as this will prevent the arbor screw from properly securing the blade. Replacement saw blades (**model BL11510W**) can be purchased from wenproducts.com.

Blade Model	Blade Type	Suitable Materials	Body Thickness	Teeth Thickness	Max Speed
BL11510W	TCT Wood-Cutting Blade (24 Teeth)	Softwood, hardwood and plastics	1.2 mm	1.8 mm	7,000 RPM

⚠ WARNING! Wear gloves when handling saw blades to prevent injuries in case the blade teeth are accidentally contacted.

1. Unplug your mini circular saw from the power source.
2. Press down the spindle lock (Fig. 1 - 1) to prevent the blade from spinning. With the spindle lock pressed down, use the included M5 hex wrench to loosen the arbor screw (Fig. 2 - 1) by turning it clockwise.
3. Remove the arbor screw, washer and outer flange.
4. Push the blade release button (Fig. 3 - 1) and swing the base plate upwards. Carefully remove the existing blade.
5. With the base plate in the upward position, slide the new saw blade onto the spindle. Make sure the blade teeth beneath the base plate are pointing forward and the arrows printed on the blade point in the clockwise direction.
6. Replace the outer flange. Press the spindle lock and replace the arbor screw and washer. Fully tighten the arbor screw by turning it counterclockwise with the hex wrench.

NOTE: The quality of the cut depends on the condition of the saw blade. Never use a dull, rusty, or damaged blade. Before operation, check the condition of the blade and replace if the blade is worn-out or damaged.

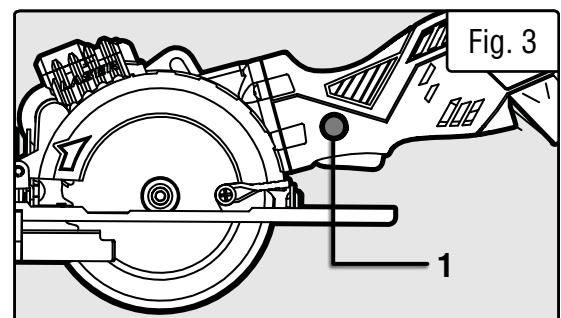
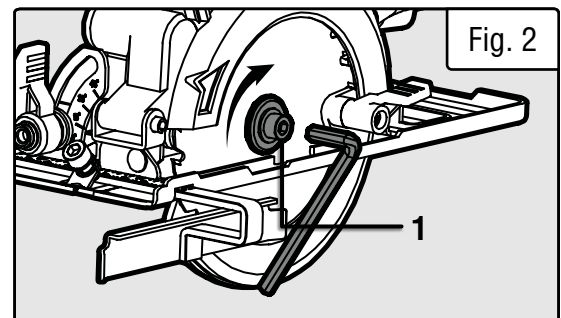
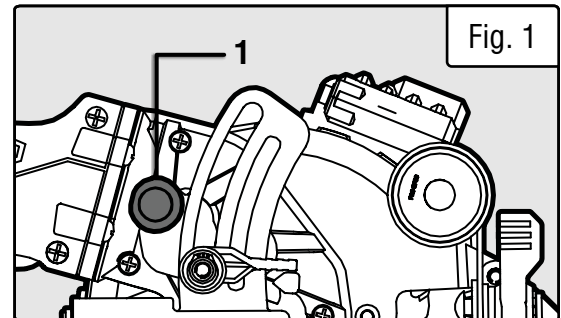

ASSEMBLY & ADJUSTMENTS

SETTING THE DEPTH OF CUT

Before making a cut, it is important to set the correct cutting depth. The saw's maximum cutting depth at 90° is 1-11/16 inch (43 mm) and at 45° it is 1-1/8" (28 mm). We recommend adjusting the cutting depth about 1/16 inch (2 mm) deeper than the thickness of the material. To adjust the cutting depth, you can either refer to the depth scale, or the edge of the workpiece.

Using the Depth Scale:

1. Unplug your mini circular saw from the power source.
2. Flip up the depth lock lever (Fig. 4 - 1) to loosen it .
3. Slide the depth lock lever so that the arrow points to your desired cutting depth indicated on the depth scale (Fig. 4 - 2).
4. Press down on the depth lock lever to securely lock the depth setting.

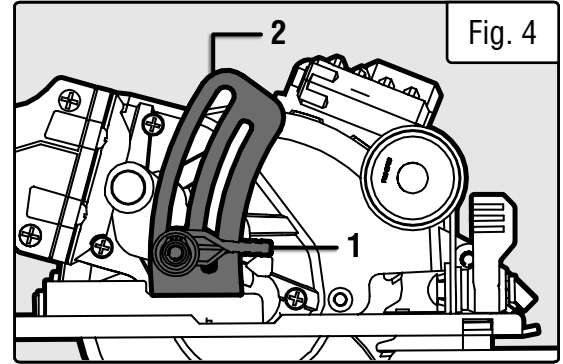

Using the Depth Scale:

1. Unplug your mini circular saw from the power source.
2. Flip up the depth lock lever to loosen it .
3. Slide the depth lock lever so that the arrow points to your desired cutting depth indicated on the depth scale.
4. Press down on the depth lock lever to securely lock the depth setting.

Using the Edge of the Workpiece:

1. Unplug your mini circular saw from the power source.
2. Flip up the depth lock lever to loosen it and slide the lever to all the way to the top of the slot.
3. Place the base plate onto the workpiece with the saw blade positioned against the left edge of the workpiece.
4. Grip the tool and press the blade release button. Lower the blade to your desired cutting depth by observing how deep the blade will cut relative to the top face of the workpiece.
5. Holding the saw in position at a constant depth, slide the depth lock lever to the left until it is flush against the edge of the inner blade guard.
6. Press down on the depth lock lever to securely lock the depth setting.

CUTTING GUIDE INDICATOR

The cutting guide indicator (Fig. 5 - 1) can be found at the front of the saw base. This guide helps to indicate where the cut will be occurring. Before cutting, draw a guideline on the workpiece and follow the guideline with the cutting guide to create more accurate cuts.

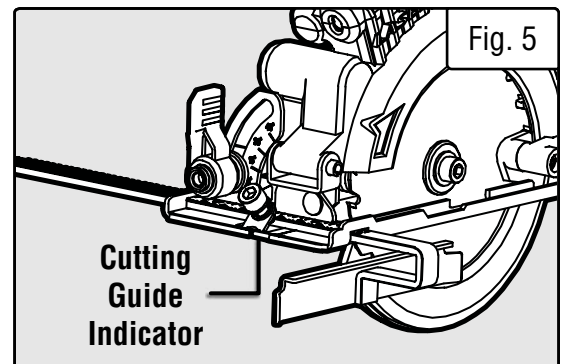

ASSEMBLY & ADJUSTMENTS

USING THE LASER

The laser (Fig. 6 - 1) located on the top of your saw can also be used to indicate the line of cut. Unscrew the laser cover and install the two AG13 batteries. Securely replace the laser cover. Switch the laser ON (Fig. 6 - 2) and align the laser line with your cutting guideline.

⚠ WARNING! Do not look directly into the laser beam with unprotected eyes. See page 8 for important rules regarding laser safety.

INSTALLING THE RIP FENCE

When making a rip cut along a straight edge, it is recommended to clamp a straight edge to the workpiece or use the included rip fence. To install the rip fence onto your saw:

1. Loosen the fence lock knob (Fig. 7 - 1) on the front of the base plate.
2. Insert the rip fence (Fig. 7 - 2) from the left side of the tool through the slots (Fig. 7 - Circles) on the base plate.
3. Adjust the rip fence to the desired width of cut indicated by the cutting guide indicator and the markings on the rip fence.
4. Tighten the fence lock knob to secure the rip fence in place.

CONNECTING THE DUST EXTRACTION HOSE

Dust and chips will be produced during operation that can harm your health and create a mess in your work area. It is recommended to extract the sawdust by connecting your tool to a dust extraction system (not included) using the included dust extraction hose.

1. Unplug your mini circular saw from the power source.
2. Attach the dust extraction hose to the dust port (Fig. 8 - 1) on the right side of your tool by pushing the hose straight onto the port.
3. Connect the rubber port end of the hose to a suitable dust extraction system. The outer diameter of the hose rubber port is a taper from 1.35 to 1.5 inches (Fig. 9).
4. Turn on the dust collector before cutting to keep saw dust away from your lungs and the work area.

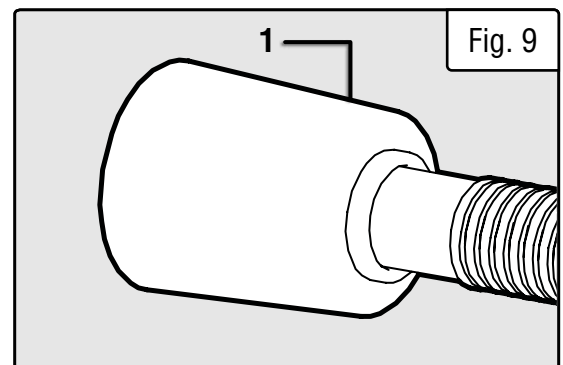
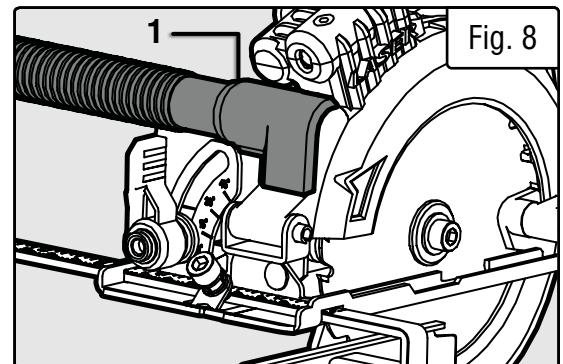
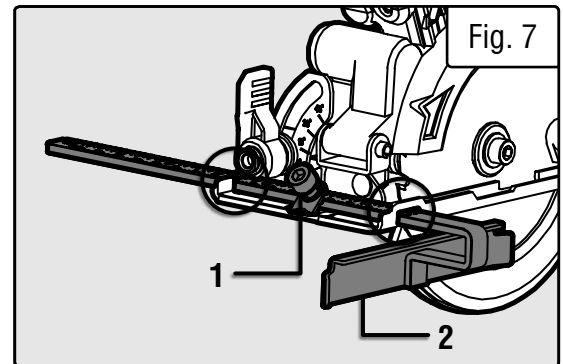
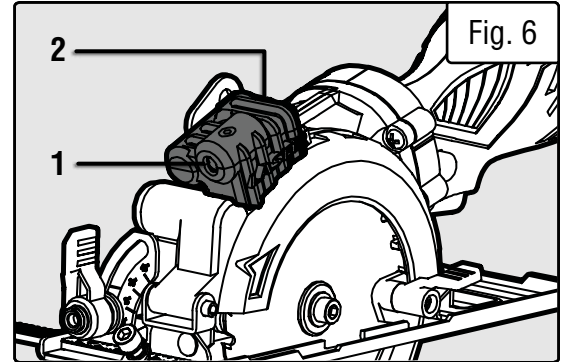

ASSEMBLY & ADJUSTMENTS

ADJUSTING THE BLADE BEVEL

Bevel your mini circular saw blade from 45° to 90° to cut your workpiece on an angle. The saw's maximum cutting depth at 90° is 1-11/16 inch (43 mm) and at 45° it is 1-1/8" (28 mm). Be sure to set your saw to the proper depth for the angle you are using (see Page. 12).

1. Unplug your mini circular saw from the power source.
2. Flip up the bevel locking knob (Fig. 10 - 1) to loosen it.
3. Adjust the bevel scale (Fig. 10 - 2) to your desired angle between 45° to 90°. Your mini circular saw is pre-set to 90°, which is a perpendicular, straight cut through your workpiece.
4. Press down on the bevel locking knob to securely tighten the bevel setting.

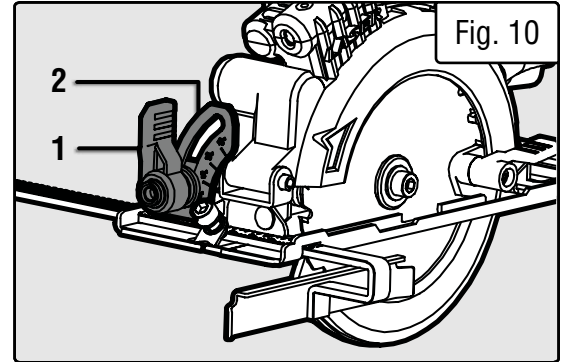

OPERATION

PREPARING FOR OPERATION

1. Prepare the work space and position power cords away from the cutting area. Connect your saw to a dust extraction system (see page 13).
2. Ensure that the saw blade is sharp. Set the correct depth of cut for your workpiece (see page 12).
3. Draw a guideline along the desired path of the cut on the workpiece surface.
4. Place the workpiece with the “good” side down (the saw blade cuts upward through the material, and may “blow out” the top side) on a flat supporting surface. Secure the workpiece in place with clamps or vises (not included). To prevent cutting into the support surface, place sufficient scrap material under the workpiece.
5. Wear safety glasses, a dust mask and hearing protection. Do not wear loose clothing or jewelry, and tie back long hair to avoid getting anything caught in the tool.

 **WARNING!** To prevent serious injury, make sure all the instructions have been read and understood before operating this tool. Check that the power switch mechanism works properly before plugging the tool into the power supply.

OPERATING THE SAW

1. Hold the tool firmly in your right hand with your thumb on the blade release button and your fingers on the power switch. Stand to the left side of the saw. (Do opposite if left-handed).
2. Set the front portion of the base plate onto the workpiece. Position the base plate with its right side resting on the larger section of board that DOES NOT fall off when being cut. Align the cutting guide indicator (see page 12) with the cutting guideline marked on the workpiece. Ensure that the blade is NOT in contact with the workpiece.
3. Pull the power switch back with your fingers to turn on the saw. Wait until the blade has reached full speed (approximately 3 seconds).
4. Make sure that the base plate is stable on the workpiece; this is very important especially during the start or finish of a cut. Push the blade release button with your thumb to lower the saw blade. Slowly push the blade into the workpiece.
5. Gently push the saw forward along the cutting guideline while keeping the base plate flat against the workpiece surface. Do not force the saw forward too quickly in order to try and hurry up the process. Let the tool work at its own pace. Never pull the saw backwards while cutting.

 **WARNING!** DO NOT start the saw while the blade is in contact with the workpiece, this may lead to kickback.

6. Let the saw blade run through the entire cut. Release the power switch and blade release button and allow the blade to come to a full stop before lifting the saw off the work surface. Disconnect the saw from the power source.

 **WARNING!** DO NOT raise the saw while it is running, this can expose you to the blade and lead to an injury. Allow the blade to completely stop before lifting it from the work surface.

MAINTENANCE

⚠ WARNING! To avoid accidents, turn OFF and unplug the tool from the electrical outlet before cleaning, adjusting, or performing any maintenance or lubrication work.

⚠ WARNING! Any attempt to repair or replace electrical parts on this tool may be hazardous. Servicing of the tool must be performed by a qualified technician. When servicing, use only identical WEN replacement parts. Use of other parts may be hazardous or induce product failure.

PREPARING FOR OPERATION

Routine inspection

Before each use, inspect the general condition of the tool. If any of these following conditions exist, do not use until parts are replaced or the sharpener is properly repaired.

Check for:

- Loose hardware or improper mounting,
- Misalignment or binding of moving parts,
- Damaged cord/electrical wiring,
- Cracked or broken parts, and
- Any other condition that may affect its safe operation

CLEANING & STORAGE

1. After every operation, use a vacuum to remove dust and chips from the tool surfaces, motor housing and work area. Keep the ventilation openings free from dust and debris to prevent the motor from overheating.
2. Wipe the tool surfaces clean with a soft cloth or brush. Make sure water does not get into the tool.
3. Periodically, remove the saw blade and vacuum out any dust that has accumulated in the blade housing.

CAUTION! Most plastics are susceptible to damage from various types of commercial solvents. Do not use any solvents or cleaning products that could damage the plastic parts. Some of these include but are not limited to: gasoline, carbon tetrachloride, chlorinated cleaning solvents, and household detergents that contain ammonia.

4. Store the tool in a clean and dry place away from the reach of children.

LUBRICATION

All ball bearings are sealed and permanently lubricated. No further lubrication is required.

PRODUCT DISPOSAL

Used power tools should not be disposed of together with household waste. This product contains electronic components that should be recycled. Please take this product to your local recycling facility for responsible disposal and to minimize its environmental impact.

TROUBLESHOOTING GUIDE

⚠ WARNING! Stop using the tool immediately if any of the following problems occur. Repairs and replacements should only be performed by an authorized technician. For any questions, please contact our customer service at **1-847-429-9263**, M-F 8-5 CST or email us at **techsupport@wenproducts.com**

PROBLEM	CAUSE	SOLUTION
Motor does not start.	1. Power cord damaged or not properly plugged in.	1. Check the power cord, extension cord, power plug and the power outlet. Make sure the outlet is functional. Do not use the tool if any cord is damaged.
	2. Defective power switch.	2. Stop using the tool and contact customer service at 1-847-429-9263 , M-F 8-5 CST for assistance.
	3. Motor carbon brushes (Part No. 36703-011) are worn.	3. Stop using the tool and contact customer service at 1-847-429-9263 , M-F 8-5 CST for assistance.
	4. Defective Motor.	4. Stop using the tool and contact customer service at 1-847-429-9263 , M-F 8-5 CST for assistance.
Ineffective cutting.	1. Cutting blade edges are dull / worn.	1. Replace the cutting blade (see page 12).
	2. Blade not suitable for the material being cut.	2. Select the correct cutting blade (see page 11) for your material.
	3. The blade is not installed properly.	3. See instructions for properly installing the blade on page 11.

EXPLODED VIEW & PARTS LIST

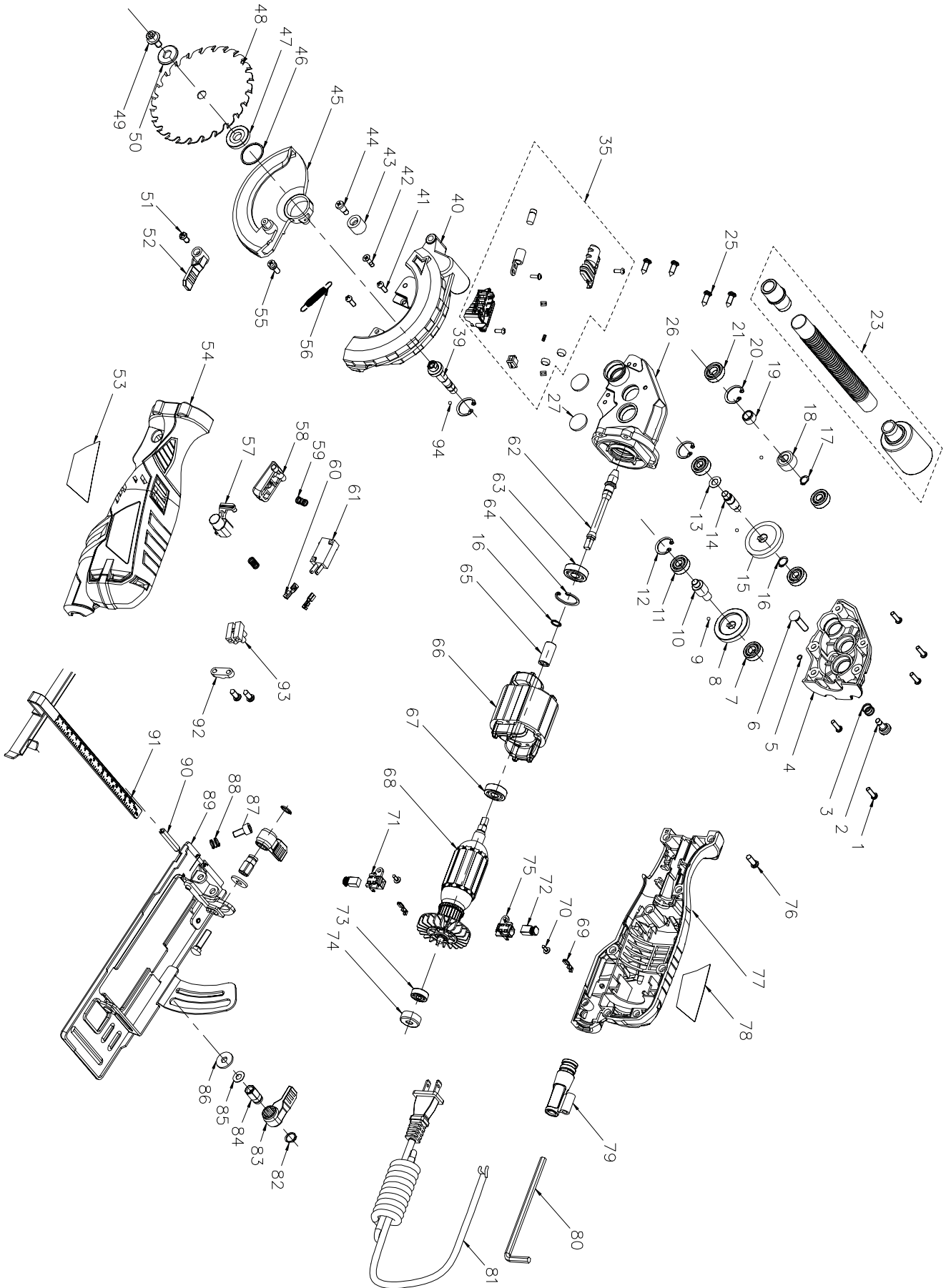

EXPLODED VIEW & PARTS LIST

No.	Part No.	Description	Qty.
1	3625-001	Screw With Washer M4x14	5
2	3625-002	Spindle Lock Button	1
3	3625-003	Spindle Lock Spring	1
4	3625-004	Gear Housing	1
5	3625-005	Baffle D4	1
6	3625-006	Square Neck Bolt M6x26	2
7	3625-007	Bearing 698	1
8	3625-008	Spiral Bevel Gear	1
9	3625-009	Ball Bearing	3
10	3625-010	Gear Shaft	1
11	3625-011	Bearing 607-2z	4
12	3625-012	C-Clip	2
13	3625-013	Spacer	1
14	3625-014	Intermediate Shaft	1
15	3625-015	Large Gear	1
16	3625-016	O-Ring	2
17	3625-017	C-Clip	1
18	3625-018	Pinion	1
19	3625-019	Spacer Sleeve	1
20	3625-020	C-Clip	2
21	3625-021	Bearing 699	1
23	3625-023	Dust Hose Assembly	1
25	3625-025	Self-Tapping Screw ST4.2x14	6
26	3625-026	Gear Housing, Left	1
27	3625-027	Cover	2
35	3625-035	Laser Assembly	1

No.	Part No.	Description	Qty.
39	3625-039	Blade Arbor	1
40	3625-040	Fixed Blade Guard	1
41	3625-041	Screw With Washer M4x12	2
42	3625-042	Cross-Shaped Screw M4x12	1
43	3625-043	Rubber Block For Lower Guard	1
44	3625-044	Screw For Rubber Block	1
33	3625-033	Blade Arbor Screw	1
34	3625-034	Left Label	1
35	3625-035	Left Housing	1
36	3625-036	Screw St4.2x12	1
37	3625-037	Lever For Blade Cover	1
38	3625-038	Reset Spring	1
39	3625-039	Screw For Reset Spring	1
40	3625-040	Screw With Washer M4x12	2
41	3625-041	Power Switch Button	1
42	3625-042	Spindle Lock Cap	1
43	3625-043	Spindle Lock Spring	2
44	3625-044	Screw For Rubber Block	1
45	3625-045	Blade Cover	1
46	3625-046	Baffle	1
47	3625-047	Inner Flange	1
48	BL11510W	Blade, TCT, 115 mm	1

NOTE: Not all parts may be available for purchase. Parts and accessories that wear down over the course of normal use are not covered under the warranty.

EXPLODED VIEW & PARTS LIST

No.	Part No.	Description	Qty.
49	3625-049	Blade Arbor Screw	1
50	3625-050	Outer Flange	1
51	3625-051	Screw St4.2x12	1
52	3625-052	Lever For Blade Cover	1
53	3625-053	Left Label	1
54	3620-057	Left Housing	1
55	3625-055	Screw For Reset Spring	1
56	3625-056	Reset Spring	1
57	3620-067	Switch Locking Button	1
58	3620-076	Switch Trigger	1
59	3625-059	Spindle Lock Spring	2
60	3625-060	Switch Terminal Insert, 4.8x0.8	2
61	3620-075	Power Switch	1
62	3620-037	Connecting Rod	1
63	3620-038	Bearing 609-2z	1
64	3620-039	C-Clip	1
65	3620-041	Connecting Sleeve	1
66	3620-042	Stator Assembly	1
67	3620-038	Bearing 608-2z	1
68	3620-043	Rotor Assembly	1
69	3620-044	Brush Terminal Insert, 2.8x0.8	2
70	3625-070	Self-Tapping Screw With Washer ST2.9x10	2

No.	Part No.	Description	Qty.
71	3620-046	Lower Brush Holder	1
72	3620-045	Carbon Brush	2
73	3620-048	Bearing 606-2z	1
74	3620-049	Bearing Sleeve	1
75	3620-050	Upper Brush Holder	1
76	3625-076	Self-Tapping Screw With Washer ST4.2x16	9
77	3620-092	Right Housing	1
78	3625-078	Right Label	1
79	3625-079	Power Cord Sheath	1
80	3625-080	Hex Wrench	1
81	3625-081	Power Cord	1
82	3625-082	C-Clip for Shaft D10	2
83	3625-083	Depth Locking Lever	2
84	3625-084	M6 Locking Pin	2
86	3625-086	Flat Washer M6	2
87	3625-087	Screw M6x12	1
88	3625-088	Rip Fence Locking Spring	1
89	3625-089	Base Plate	1
90	3625-090	Cylindrical Spring Pin D6x35	1
91	3625-091	Rip Fence	1
92	3625-092	Cord Clamp	1
93	3625-093	Relay	1
94	3625-094	Ball Bearing	1

NOTE: Not all parts may be available for purchase. Parts and accessories that wear down over the course of normal use are not covered under the warranty.

WARRANTY STATEMENT

WEN Products is committed to building tools that are dependable for years. Our warranties are consistent with this commitment and our dedication to quality.

LIMITED WARRANTY OF WEN PRODUCTS FOR HOME USE

GREAT LAKES TECHNOLOGIES, LLC (“Seller”) warrants to the original purchaser only, that all WEN consumer power tools will be free from defects in material or workmanship during personal use for a period of two (2) years from date of purchase or 500 hours of use; whichever comes first. Ninety days for all WEN products if the tool is used for professional or commercial use. Purchaser has 30 days from the date of purchase to report missing or damaged parts.

SELLER’S SOLE OBLIGATION AND YOUR EXCLUSIVE REMEDY under this Limited Warranty and, to the extent permitted by law, any warranty or condition implied by law, shall be the replacement of parts, without charge, which are defective in material or workmanship and which have not been subjected to misuse, alteration, careless handling, misrepair, abuse, neglect, normal wear and tear, improper maintenance, or other conditions adversely affecting the Product or the component of the Product, whether by accident or intentionally, by persons other than Seller. To make a claim under this Limited Warranty, you must make sure to keep a copy of your proof of purchase that clearly defines the Date of Purchase (month and year) and the Place of Purchase. Place of Purchase must be a direct vendor of Great Lakes Technologies, LLC. Purchasing through third party vendors, including but not limited to garage sales, pawn shops, resale shops, or any other secondhand merchant, voids the warranty included with this product. Contact techsupport@wenproducts.com or 1-847-429-9263 with the following information to make arrangements: your shipping address, phone number, serial number, required part numbers, and proof of purchase. Damaged or defective parts and products may need to be sent to WEN before the replacements can be shipped out.

Upon the confirmation of a WEN representative, your product may qualify for repairs and service work. When returning a product for warranty service, the shipping charges must be prepaid by the purchaser. The product must be shipped in its original container (or an equivalent), properly packed to withstand the hazards of shipment. The product must be fully insured with a copy of the proof of purchase enclosed. There must also be a description of the problem in order to help our repairs department diagnose and fix the issue. Repairs will be made and the product will be returned and shipped back to the purchaser at no charge for addresses within the contiguous United States.

THIS LIMITED WARRANTY DOES NOT APPLY TO ITEMS THAT WEAR OUT FROM REGULAR USAGE OVER TIME, INCLUDING BELTS, BRUSHES, BLADES, BATTERIES, ETC. ANY IMPLIED WARRANTIES SHALL BE LIMITED IN DURATION TO TWO (2) YEARS FROM DATE OF PURCHASE. SOME STATES IN THE U.S. AND SOME CANADIAN PROVINCES DO NOT ALLOW LIMITATIONS ON HOW LONG AN IMPLIED WARRANTY LASTS, SO THE ABOVE LIMITATION MAY NOT APPLY TO YOU.

IN NO EVENT SHALL SELLER BE LIABLE FOR ANY INCIDENTAL OR CONSEQUENTIAL DAMAGES (INCLUDING BUT NOT LIMITED TO LIABILITY FOR LOSS OF PROFITS) ARISING FROM THE SALE OR USE OF THIS PRODUCT. SOME STATES IN THE U.S. AND SOME CANADIAN PROVINCES DO NOT ALLOW THE EXCLUSION OR LIMITATION OF INCIDENTAL OR CONSEQUENTIAL DAMAGES, SO THE ABOVE LIMITATION OR EXCLUSION MAY NOT APPLY TO YOU.

THIS LIMITED WARRANTY GIVES YOU SPECIFIC LEGAL RIGHTS, AND YOU MAY ALSO HAVE OTHER RIGHTS WHICH VARY FROM STATE TO STATE IN THE U.S., PROVINCE TO PROVINCE IN CANADA AND FROM COUNTRY TO COUNTRY.

THIS LIMITED WARRANTY APPLIES ONLY TO ITEMS SOLD WITHIN THE UNITED STATES OF AMERICA, CANADA AND THE COMMONWEALTH OF PUERTO RICO. FOR WARRANTY COVERAGE WITHIN OTHER COUNTRIES, CONTACT THE WEN CUSTOMER SUPPORT LINE. FOR WARRANTY PARTS OR PRODUCTS REPAIRED UNDER WARRANTY SHIPPING TO ADDRESSES OUTSIDE OF THE CONTIGUOUS UNITED STATES, ADDITIONAL SHIPPING CHARGES MAY APPLY.

**THANKS FOR
REMEMBERING**  [®]