

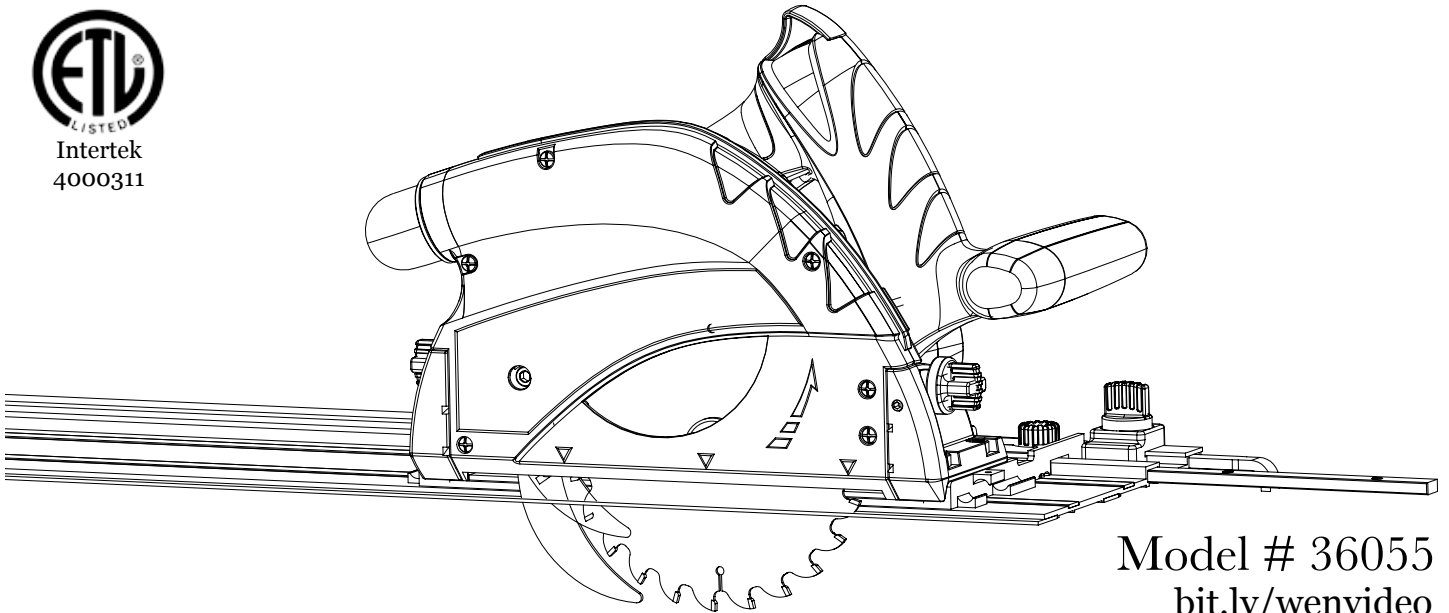

6-1/4 IN. TRACK SAW



Model # 36055
bit.ly/wenvideo

IMPORTANT:

Your new tool has been engineered and manufactured to WEN's highest standards for dependability, ease of operation, and operator safety. When properly cared for, this product will supply you years of rugged, trouble-free performance. Pay close attention to the rules for safe operation, warnings, and cautions. If you use your tool properly and for intended purpose, you will enjoy years of safe, reliable service.



NEED HELP? CONTACT US!

Have product questions? Need technical support?
Please feel free to contact us at:



800-232-1195 (M-F 8AM-5PM CST)



techsupport@wenproducts.com



WENPRODUCTS.COM

TABLE OF CONTENTS

Technical Data	2
General Safety Rules	3
Specific Safety Rules For Track Saw	4
Electrical Information	7
Know Your Track Saw	8
Assembly and Adjustments	9
Operation	12
Maintenance	14
Exploded View and Parts List	15
Warranty	18

TECHNICAL DATA

Model Number:	36055
Motor:	120 V, 60 Hz, 9A
Speed (no load):	5500 RPM
Arbor Size:	20 mm
Blade Size:	160 mm
Blade Tilt:	0° to 45°
Cutting Capacity at 90° w/o Track:	2-5/32 in.
Cutting Capacity at 45° w/o Track:	1-5/8 in.
Cutting Capacity at 90° w/ Track:	1-31/32 in.
Cutting Capacity at 45° w/ Track:	1-7/16 in.
Product Dimensions:	13 x 10.6 x 9.3 in.
Product Weight:	11 lbs
Contents:	Two Pieces of 27.5 in. Track (model 36027) One Track Connector One Track Saw Stabilizer One Track Stop

GENERAL SAFETY RULES

Safety is a combination of common sense, staying alert and knowing how your item works. **SAVE THESE SAFETY INSTRUCTIONS.**



WARNING: To avoid mistakes and serious injury, do not plug in your tool until the following steps have been read and understood.

1. **READ** and become familiar with this entire instruction manual. **LEARN** the tool's applications, limitations, and possible hazards.
2. **AVOID DANGEROUS CONDITIONS.** Do not use power tools in wet or damp areas or expose them to rain. Keep work areas well lit.
3. **DO NOT** use power tools in the presence of flammable liquids or gases.
4. **ALWAYS** keep your work area clean, uncluttered, and well lit. **DO NOT** work on floor surfaces that are slippery with sawdust or wax.
5. **KEEP BYSTANDERS AT A SAFE DISTANCE** from the work area, especially when the tool is operating. **NEVER** allow children or pets near the tool.
6. **DO NOT FORCE THE TOOL** to do a job for which it was not designed.
7. **DRESS FOR SAFETY.** Do not wear loose clothing, gloves, neckties, or jewelry (rings, watches, etc.) when operating the tool. Inappropriate clothing and items can get caught in moving parts and draw you in. **ALWAYS** wear non-slip footwear and tie back long hair.
8. **WEAR A FACE MASK OR DUST MASK** to fight the dust produced by sawing operations.



WARNING: Dust generated from certain materials can be hazardous to your health. Always operate the tool in a well-ventilated area and provide for proper dust removal. Use dust collection systems whenever possible.

9. **ALWAYS** remove the power cord plug from the electrical outlet when making adjustments, changing parts, cleaning, or working on the tool.
10. **KEEP GUARDS IN PLACE AND IN WORKING ORDER.**
11. **AVOID ACCIDENTAL START-UPS.** Make sure the power switch is in the **OFF** position before plugging in the power cord.
12. **REMOVE ADJUSTMENT TOOLS.** Always make sure all adjustment tools are removed from the saw before turning it on.
13. **NEVER LEAVE A RUNNING TOOL UNATTENDED.** Turn the power switch to **OFF**. Do not leave the tool until it has come to a complete stop.
14. **NEVER STAND ON A TOOL.** Serious injury could result if the tool tips or is accidentally hit. **DO NOT** store anything above or near the tool.

GENERAL SAFETY RULES

15. **DO NOT OVERREACH.** Keep proper footing and balance at all times. Wear oil-resistant rubber-soled footwear. Keep the floor clear of oil, scrap, and other debris.
16. **MAINTAIN TOOLS PROPERLY.** ALWAYS keep tools clean and in good working order. Follow instructions for lubricating and changing accessories.
17. **CHECK FOR DAMAGED PARTS.** Check for alignment of moving parts, jamming, breakage, improper mounting, or any other conditions that may affect the tool's operation. Any part that is damaged should be properly repaired or replaced before use.
18. **MAKE THE WORKSHOP CHILDPROOF.** Use padlocks and master switches and ALWAYS remove starter keys.
19. **DO NOT** operate the tool if you are under the influence of drugs, alcohol, or medication that may affect your ability to properly use the tool.
20. **USE SAFETY GOGGLES AT ALL TIMES** that comply with ANSI Z87.1. Normal safety glasses only have impact resistant lenses and are not designed for safety. Wear a face or dust mask when working in a dusty environment. Use ear protection such as plugs or muffs during extended periods of operation.

SPECIFIC RULES FOR TRACK SAWS



WARNING: Do not let comfort or familiarity with product (gained from repeated use) replace strict adherence to product safety rules. If you use this tool unsafe or incorrectly, you can suffer serious personal injury!

1. Hold the tool by insulated gripping surfaces when performing an operation where the tool may contact hidden wiring. Contact with a “live” wire will make exposed metal parts of the tool “live” and shock the operator.
2. **DANGER!** Keep hands away from the cutting area and the blade. Keep your second hand on the auxiliary handle or motor housing. If both hands are holding the saw handles, they cannot be cut by the blade. Keep your body positioned to either side of the saw blade, but not in line with the saw blade. **KICKBACK** could cause the saw to jump backwards. Do not reach underneath the workpiece. The guard cannot protect you from the blade protruding from the underside of the workpiece. Do not attempt to remove cut material when the blade is moving.

CAUTION: Blades coast after turning the saw off. Wait until the blade stops before reaching for loose material.

3. Always make sure the saw blades are sharp, undamaged and tightly attached before each use. Only use blades that meet all the specifications of this particular model of saw. Do not use blades with incorrect diameters or mismatched arbor holes. They will not rotate correctly and may damage the saw or injure the user.
4. Make sure the riving knife is thicker than the saw blade and thinner than the blade teeth. The riving knife must be present in the kerf and properly adjusted with the blade in order to maximize effectiveness.
5. Make sure that all guards are in proper place and working condition before each cut. Do not operate if broken.
6. Always observe that the blade has properly retracted before placing the saw down on a bench or floor. An unprotected, coasting blade will cause the saw to walk backwards, cutting whatever is in its path.

SPECIFIC RULES FOR TRACK SAWS

7. Never hold a workpiece in your hands or across your legs during sawing operations. It is important to support the work properly to minimize body exposure, blade binding, or loss of control.

8. When ripping, always use a rip fence or straight edge guide. This improves the accuracy of the cut and reduces the chance for blade binding.

9. Always use blades with correct size and shape (diamond vs. round) arbor holes. Blades that do not match the mounting hardware of the saw will run eccentrically, causing a loss of control.

10. Kickback is a sudden reaction to a pinched, bound or misaligned saw blade, causing an uncontrolled saw to lift up and out of the work piece toward the operator. When the blade is pinched or bound tightly by the kerf closing down, the blade stalls and the motor reaction drives the unit rapidly back toward the operator. If the blade becomes twisted or misaligned in the cut, the teeth at the back edge of the blade can dig into the top surface of the wood causing the blade to climb out of the kerf and jump back towards the operator. Kickback is the result of tool misuse or incorrect operating procedures of conditions and can be avoided by taking proper precautions as given below:

- Maintain a firm grip on the saw and position your body and arm in a way that allows you to resist kickback forces. Kickback forces can be controlled by the operator, if proper precautions are taken.
- When a blade is binding (or when interrupting a cut for any reason), release the trigger and hold the saw motionless in the material until the blade comes to a complete stop. Never attempt to remove the saw from the work or pull the saw backward while the blade is in motion or kickback may occur. Investigate and take corrective actions to eliminate the causes of blade binding.
- When restarting a saw in the workpiece, center the blade in the kerf and check that the teeth are not engaged into the material. If the saw blade is binding, it may walk up or kickback from the work piece as the saw is restarted.
- Support large panels to minimize the risk of blade pinching and kickback. Large panels tend to sag under their own weight. Supports must be placed under the panel on both sides, near the line of the cut and near the edge of the panel.
- Do not use dull or damaged blades. Unsharpened or improperly set blades produce narrow kerf, causing excessive friction, blade binding, and kickback.
- Blade depth and bevel adjusting locking levers must be tight and secure before making a cut. If the blade adjustment shifts while cutting, it will cause binding and **KICKBACK**.
- Use extra caution when making a “Pocket Cut” into existing walls or other blind areas. The protruding blade may cut the objects that can cause kickback.

11. Always set the cutting depth so the blade doesn't protrude more than 1/8 of an inch past the bottom of the workpiece.

12. Only make straight cuts. Never make freehand cuts. Allow the blade to reach full speed before starting a cut.

13. If a cut is interrupted, let the blade come to a complete stop before taking it out of the workpiece. Before continuing the cut, place the blade in the kerf to make sure its teeth do not touch the workpiece.

SPECIFIC RULES FOR TRACK SAWS

14. Make sure the blade you are using is the correct type for the material being cut. Do not cut logs or shrubbery with this saw. Only cut flat workpieces.
15. Always make sure that the cutting path, including underneath the workpiece, is free of obstructions before cutting, particularly during plunge cuts.
16. Always adequately support the workpiece.
17. Never use damaged or incorrect blade washers or bolts. The blade washers and bolts were specially designed for your saw with optimum performance and safety of operation in mind.
18. Do not leave the tool running. Operate the tool only while holding it in your hands.
19. When operating the tool from an elevated position, be aware of people or things beneath you.
20. Always hold the tool firmly in your hands before switching the tool "ON." The reaction to the torque of the motor as it accelerates to full speed may cause the tool to twist.
21. Wear eye and hearing protection. Always use safety glasses with side shields. Everyday glasses provide only limited impact resistance unless otherwise specified. They are not safety glasses. Only use certified safety equipment. Eye protection equipment should comply with ANSI z87.1 standards. Protective hearing equipment should comply with ANSI s3.19 standards.
22. Protect your lungs. Wear a face or dust mask if the operation is dusty. Following this rule will reduce the risk of personal injury.
23. These instructions can't possibly warn of every scenario that may arise with this tool, so always make sure to use common sense during operation.



WARNING: Read and understand all warnings, cautions and operating instructions before using this equipment. Failure to follow all instructions listed below may result in electric shock, fire and/or serious personal injury.

SAVE THESE INSTRUCTIONS

ELECTRICAL INFORMATION

GROUNDING INSTRUCTIONS

IN THE EVENT OF A MALFUNCTION OR BREAKDOWN, grounding provides the path of least resistance for an electric current and reduces the risk of electric shock. This tool is equipped with an electric cord that has an equipment grounding conductor and a grounding plug. The plug **MUST** be plugged into a matching outlet that is properly installed and grounded in accordance with **ALL** local codes and ordinances.

DO NOT MODIFY THE PLUG PROVIDED. If it will not fit the outlet, have the proper outlet installed by a licensed electrician.

IMPROPER CONNECTION of the equipment grounding conductor can result in electric shock. The conductor with the green insulation (with or without yellow stripes) is the equipment grounding conductor. If repair or replacement of the electric cord or plug is necessary, **DO NOT** connect the equipment grounding conductor to a live terminal.

CHECK with a licensed electrician or service personnel if you do not completely understand the grounding instructions or whether the tool is properly grounded.

CAUTION: In all cases, make certain the outlet in question is properly grounded. If you are not sure, have a licensed electrician check the outlet.



WARNING: This tool is for indoor use only. Do not expose to rain or use in damp locations.
Guidelines for using extension cords

Make sure your extension cord is in good condition. When using an extension cord, be sure to use one heavy enough to carry the current your product will draw. An undersized cord will cause a drop in line voltage resulting in loss of power and overheating. The table below shows the correct size to be used according to cord length and nameplate ampere rating. When in doubt, use a heavier cord. The smaller the gauge number, the heavier the cord.

AMPERAGE	REQUIRED GAUGE FOR EXTENSION CORDS			
	25 ft.	50 ft.	100 ft.	150 ft.
9A	18 gauge	16 gauge	14 gauge	12 gauge

Make sure your extension cord is properly wired and in good condition. Always replace a damaged extension cord or have it repaired by a qualified person before using it.

Protect your extension cords from sharp objects, excessive heat and damp/wet areas.

Use a separate electrical circuit for your tools. This circuit must not be less than a #12 wire and should be protected with a 15 A time-delayed fuse. Before connecting the motor to the power line, make sure the switch is in the OFF position and the electric current is rated the same as the current stamped on the motor nameplate. Running at a lower voltage will damage the motor.

KNOW YOUR TRACK SAW

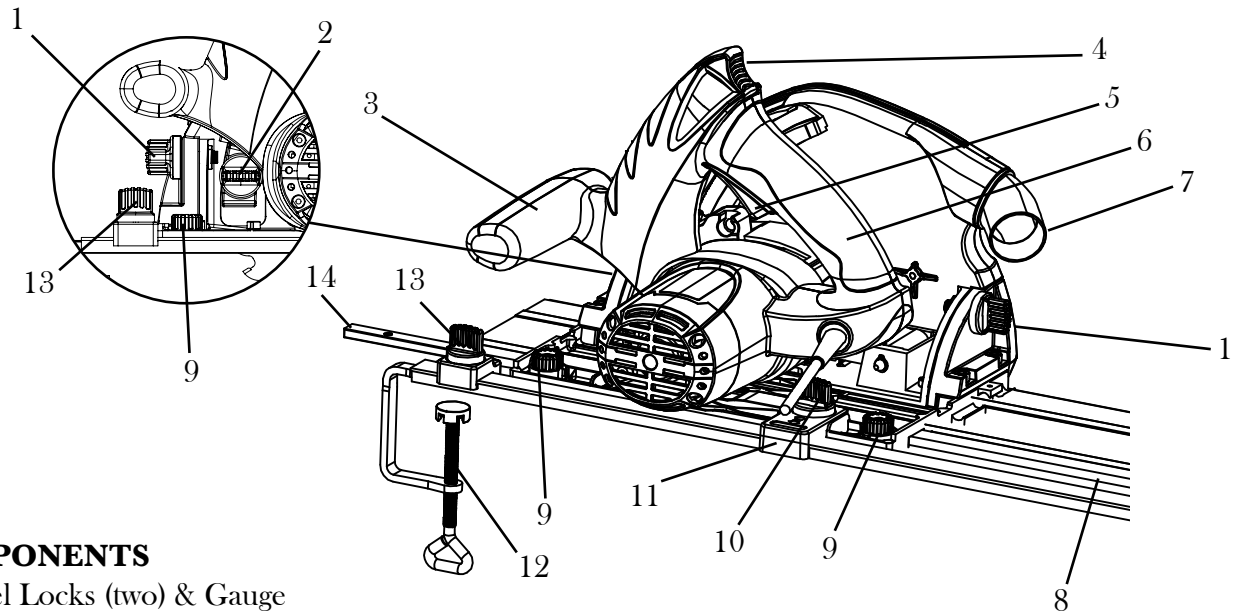

COMPONENTS

1. Bevel Locks (two) & Gauge
2. Depth Adjustment Lock & Gauge
3. Front Handle
4. Safety (Plunge Release)
5. Trigger Switch
6. Main Handle
7. Dust Port
8. Track
9. Position Lock Knobs
10. Track Stabilizer Lock
11. Track Stabilizer
12. Track Clamp (sold separately)
13. Track Stop
14. Track Adapter

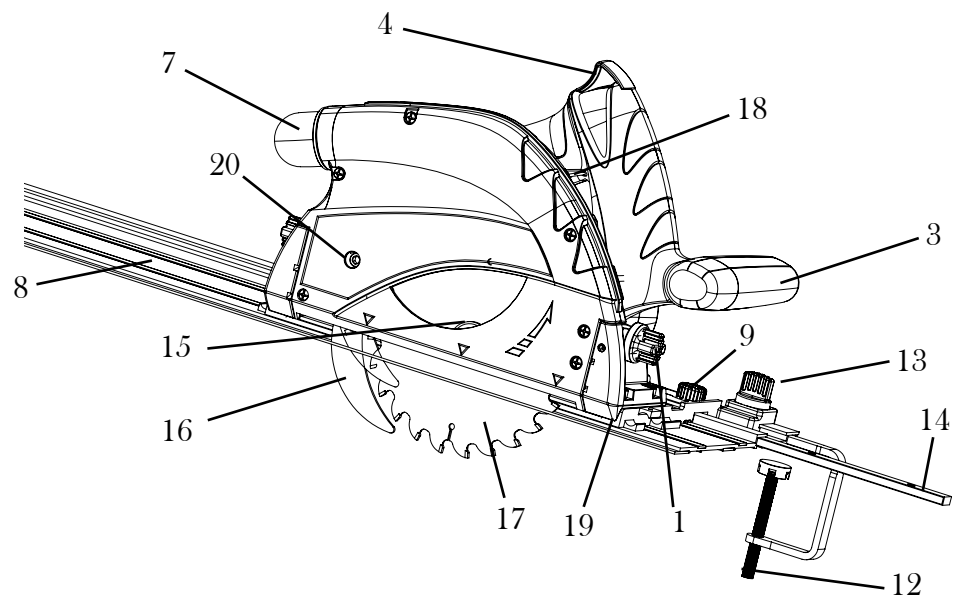

15. Arbor Bolt
16. Riving Knife
17. Saw Blade
18. Spindle Blade Lock
19. Line-of-Cut Indicator
20. Riving Knife Adjustment Access Point

ASSEMBLY AND ADJUSTMENTS



WARNING: Always be sure that the tool is switched off and unplugged before adjusting, adding accessories, or checking a function on the tool.



WARNING: 6-1/4 in. is the maximum blade capacity of your saw. Never use a blade that is too thick to allow the outer flange washer to fit properly on the spindle. An overly thick blade will prevent the blade bolt from securing the blade on the spindle. Larger diameter blades will contact the blade guards. Either situation could result in a serious accident.

ADJUSTING THE DEPTH OF CUT

1. Unplug your track saw.
2. Loosen the depth adjustment lock and slide it up or down so the top of the gauge is flush with the depth that you would like to cut at.
3. Lock the depth gauge in place. Test the depth to make sure it seems correct before plugging the saw back in.

NOTE: Always maintain the correct blade-depth setting. All cuts should not exceed 1/8 in. below the material being cut, as excessive blade depth increases the chance of saw kickback and contact with hidden surfaces beneath the workpiece.

ADJUSTING THE ANGLE OF THE CUT

1. Unplug the saw.
2. Loosen the bevel locks found on the front and back of the saw. Bevel the saw so that the angle indication arrow is pointed at the desired angle.
3. Tighten the bevel lock knob securely.
4. Make a test cut in scrap lumber and measure the angle of the cut to confirm that the bevel angle is properly set. If necessary, adjust the bevel angle appropriately before cutting the actual work piece.

NOTE: Adjust the angle indication arrow as needed if angles are consistently incorrect by loosening the inside screw found on the interior lip of the bevel gauge.

LINE-OF-CUT INDICATORS

A line-of-cut indicator notch can be found at the front and back of the saw base. This notch helps provide indication of where the cut will be occurring.

NOTE: Since blade thicknesses vary, it is necessary to make test cuts along a guideline in scrap material to determine the proper alignment of the guideline within the notch. This will help to obtain an accurate cut with blades of various thicknesses.

ASSEMBLY AND ADJUSTMENTS

SETTING UP THE TRACK

1. Using the track adapters, link together enough track to account for the entire workpiece. To do so, insert the track adapters into the inner grooves of each rail. Once the tracks have been connected together, flip the track over and check that the adapter is split evenly between the two tracks. Tighten the adapter's set screws in place using a hex wrench.
2. Align the rail track along the workpiece, the right-hand (flat) side of the track being where the actual cut will occur. Clamp down the track to the work surface until the track is secure.
3. Place the saw onto the rail, making sure the blade will correctly contact the workpiece as intended.
4. Adjust the rail adjustment knobs to correctly line up the rail's edge and the saw's cutting path with one another.

NOTE: Always maintain the correct blade-depth setting. All cuts should not exceed 1/8 in. below the material being cut, as excessive blade depth increases the chance of saw kickback and contact with hidden surfaces beneath the workpiece.

PREPARING THE TRACK

The rubber strip running along the edge of the track has been shipped in its uncut original state. This rubber strip has two main applications. First, it acts as a straightedge, allowing users to visualize the exact location of the cut. Secondly, it helps prevent dust from flying up during sawing operations. Because of the precision required for these two applications, users must cut this rubber strip themselves before using the track saw on any work pieces. This ensures every track perfectly complements a particular track saw.

The following instructions will help you to properly prepare your track for maximum efficiency as both a dust control device and as a guiding straightedge. Refer to page 12 for information about starting and stopping the saw.

1. Set the depth stop to 1/2 inch, limiting the blade's maximum cutting depth.
2. Clamp the track into place so that you can cut the full length of the track in one go.
3. Position the saw onto the end of the track with the back two-thirds of the saw hanging off. The goal should be to maximize the amount of the saw's base that is on the track while still being able to plunge the full 1/2 inch downwards without yet contacting the rubber strip with the blade.
4. Start the saw and then plunge downwards, making sure to not yet contact the rubber strip. Once the saw has reached full speed and is plunged the full 1/2 inch, progress forward along the track so that the blade makes contact with the rubber strip.
5. Cut the rubber strip along the full length of the track. Once you have made it all the way down the track, the strip should be precision cut to meet the specifications of your particular track saw.

Replacement rubber strips can be ordered at wenproducts.com under part number 36027-001.

ASSEMBLY AND ADJUSTMENTS

RIVING KNIFE ADJUSTMENT

The riving knife helps prevent kickback by keeping the two sides of your cut from closing on the blade. Before operation, make sure the riving knife is properly aligned with the blade. This requires checking the distance between the blade and the riving knife, making sure it is no greater than 1/8 of an inch.

1. Engage the plunge release and lower the blade down until the riving knife lock can be seen through the riving knife adjustment access point in the side of the saw.
2. Using a hex wrench (5mm), loosen the bolt through the riving knife adjustment access point.
3. Manually position the riving knife approximately 1/8 of an inch away from the teeth of the saw blade, checking to make sure that the tip of the riving knife is slightly above (1/8 of an inch) the lowest point of the blade.
4. Tighten the riving knife locking bolt. Once the bolt is tight, make sure that the knife itself is straight and properly aligned with the blade. Check this with a straight edge or a T-square, pressing it against the side of the riving knife and the blade to see if it lies flush against both objects.



WARNING: Never use a warped blade or riving knife. If the riving knife seems bent or misaligned, do not operate the track saw.

USING THE TRACK STABILIZER

The stabilizer is an added measure to prevent the track saw from separating from the track during operation. Loosen the thumb screw on the stabilizer and set the track saw onto the track. Once the saw is sitting properly on the track, adjust the stabilizer around the outside lip of the track (opposite of the blade). Tighten the stabilizer to prevent the track from tipping during operation.

ADJUSTING THE STOP

The package includes a track stop to prevent your saw from going past the intended end point. Position the stop on the outer rail on the opposite side of the saw's blade for a stable stopping point during cuts. This is particularly useful during internal plunge cuts.

OPERATION



WARNING: Before plugging in the tool, always check to see that the tool is turned off. Accidentally starting the saw could result in injury.

TO START THE SAW

After checking the correct alignment of the riving knife and blade, plug in the tool. In order to start the saw, pull the trigger switch. Once the saw reaches maximum speed, press and hold the safety switch to allow for the saw to plunge downwards.



WARNING: Always let the blade reach full speed before guiding the saw into the work piece. The blade coming into contact with the work piece before reaching full speed, could cause your saw to **KICKBACK** towards you resulting in serious personal injury.

TO STOP THE SAW

Release the trigger switch. Allow the blade to come to a complete stop.

NOTE: Do not remove your saw from the work piece while the blade is still moving.

OPERATING THE SAW

1. Hold the tool firmly with both hands, using both the front grip and the rear handle.
2. Avoid placing your hand on the workpiece while making a cut.
3. Place the workpiece with the “good” side down.
4. Set-up and support the workpiece so the cut is always on your right. The larger (left) side of the saw’s base should be on the part that **DOES NOT** fall off when a cut is made.
5. Securely clamp the workpiece so it will not move during the cut.
6. Place a clamp near the cut to further support the workpiece. Make sure the clamp is as close to the cut as possible without getting in the way of the saw’s line of motion.
7. Draw a guideline along the desired path of the cut before starting your saw or the cut. Set up the track to meet the needs of your particular guideline (see “Setting Up the Track” on page 10).
8. Keep the cord away from the cutting area. Position the cord to prevent it from hanging up on the workpiece and stop you from standing or tripping on the cord during operation.



DANGER: If, while operating the saw, the cord hangs up on the work piece or some other object during a cut, release the switch trigger immediately. Unplug the saw and reposition the cord to prevent it from hanging up again.

CAUTION: To make sawing easier and safer, be sure to move the tool forward gently in a straight line. Never force or twist the saw during operation. Forcing or twisting the tool will result in overheating the motor and will increase the chances of dangerous kickback, possibly causing severe personal injury.

OPERATION

CROSS-CUTTING AND RIP CUTTING

Cutting directly across the grain of a piece of wood is called crosscutting and is likely the most common type of cut done with a track saw. Cutting wood lengthwise, or with the grain, is referred to as rip cutting (or also, simply just “ripping”). Both types of cuts are performed in the same manner with the exception of the methods used to support and secure the work piece for cutting. After you have secured the work piece in position, positioned the cord so it won’t be cut or hung up, performed the saw set-up adjustments, made the necessary measurements, drawn a straight guideline, and put on your eye protection, you can begin the cutting operation.

1. Hold the tool firmly using both the front grip and rear handle. Use both gripping areas to best hold and control the saw. If both hands are holding the saw, they cannot be cut by the blade.
2. Set the front portion of the saw’s base on the workpiece to be cut without the blade making any contact. Align the line-of-cut indicator notch on the right side of the base with your guideline.
3. Turn the saw on by pressing the safety switch and the trigger. Wait until the blade reaches full speed.
4. Ease the tool forward over the workpiece surface, keeping it flat and advancing smoothly while following your guideline until sawing is completed.
5. Once the cut is complete, release the switch trigger. Wait for the blade to completely stop. Check that the lower guard has returned to position surrounding the blade. Now you can safely remove the saw from the workpiece and set it out of the way.
6. To achieve clean cuts, keep your sawing line straight while smoothly advancing forward. Do not force the saw forward too quickly in order to try and hurry up the process. Let the tool work at its own pace.
7. If the cut fails to properly follow your intended cut line, do not attempt to turn or force the tool back to the cut line. Doing so may bind the blade and lead to dangerous kickback and possible serious injury. Instead, release the switch trigger, wait for the blade to stop, and then remove the tool. Realign saw on a new cut guideline and start the cut again.
8. Position yourself in a way that allows you to avoid the wooden chips and dust being ejected from the saw.

BEVEL CUTTING

For instructions on how to bevel the saw blade, see “Adjusting the Angle of the Cut” on page 9.

Bevel cuts are made using the same technique as crosscuts and ripping described in the previous section. The difference is that the blade is set at a tilted angle between 0° and 45°. A bevel cut made at an angle to the edge of a board is called a compound miter.

There are tools better suited for bevel and compound cuts than the hand-held plunge saw. Although the inner line-of-cut indicator notch aids the operator in following the cut’s guideline, the tilted motor housing sometimes obstructs the operator’s ability to see the blade, making accurate cuts difficult. Before taking on a project with numerous compound or bevel cuts it’s suggested that the inexperienced saw user spends time making practice cuts in scrap lumber to become familiar with and overcome difficulties associated with compound/bevel cutting.

NOTE: Keep in mind that bevel cutting may misalign or alter the rubber strip along the edge of your track.

OPERATION

PLUNGE CUTS

A plunge cut is a cut that must be made inside the area of the workpiece rather than starting from an outside edge and working inward. Adjust the cutting depth and the riving knife accordingly.

1. Adjust the bevel setting to zero.
2. Set the blade to the correct blade depth setting and position it where you would like your cut to occur. You will find three arrows along the side of the saw. The rear arrow (Fig. A - 1) and the front arrow (Fig. A - 3) show the maximum points that the saw's blade will reach while the center arrow (Fig. A - 2) marks the location of the blade's center.
3. Press the safety release switch to allow the saw to plunge downwards, not allowing the blade to actually contact the work piece.
4. Power the saw on by pulling the trigger switch, allowing it to reach full speed.
5. Once the blade has reached its maximum RPM, lower the blade down into the workpiece until the set cutting depth has been reached. Once the saw cannot be lowered anymore, move the saw along the desired cut in an even and steady motion.

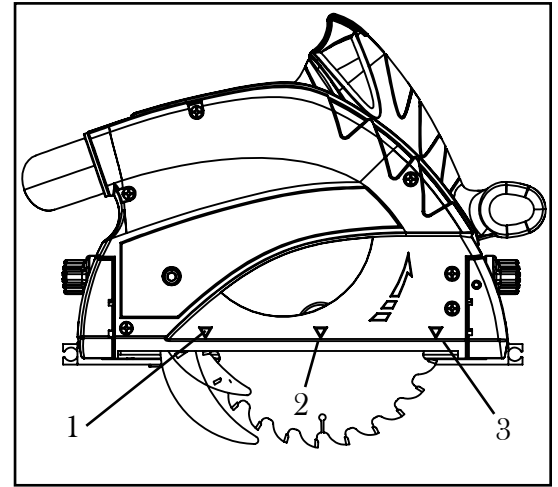

 **WARNING:** Always cut in a forward direction when pocket cutting. Cutting in the reverse direction could cause the saw to climb up on the work piece and back toward you.

MAINTENANCE

CHANGING THE BLADE

NOTE: Always make sure your replacement blade has a correctly matching arbor that can handle speeds of at least 6000 RPM.

1. Unplug your track saw.
2. Press the plunge release and lower the blade down low enough to where the arbor and arbor bolt can be seen through the window on the right-hand side of the machine.
3. Press and hold the spindle lock found on the right-hand side of the front handle. This will prevent the blade from rotating.
4. Using the provided hex wrench, unscrew the arbor bolt. Carefully remove the loosened bolt and washer from the arbor flange and set them to the side.
5. Swap the old blade out with the new one. Once the new blade has been properly mounted on the arbor flange, replace the arbor washer and the arbor bolt. Engage the spindle lock and tighten the bolt into place with the hex wrench.

MAINTENANCE

CLEANING

Avoid using solvents when cleaning plastic parts. Most plastics are susceptible to damage from various types of commercial solvents and may be damaged by their use. Use clean cloths to remove dirt, dust, oil, grease, etc.



WARNING: Do not at any time let brake fluids, gasoline, petroleum-based products, penetrating oils, etc., come in contact with plastic parts. Chemicals can damage, weaken or destroy plastic which may result in serious personal injury.

Electric tools used on fiberglass material, wallboard, spackling compounds, or plaster are subject to accelerated wear and possible premature failure because the fiberglass chips and grindings are highly abrasive to bearings, brushes, commutators, etc. Consequently, we do not recommend using this tool for extended work on these types of materials. However, if you do work with any of these materials, it is extremely important to clean the tool using compressed air after operation.

LUBRICATION

This tool is lubricated at the factory and requires no additional lubrication.

EXPLODED VIEW AND PARTS LIST

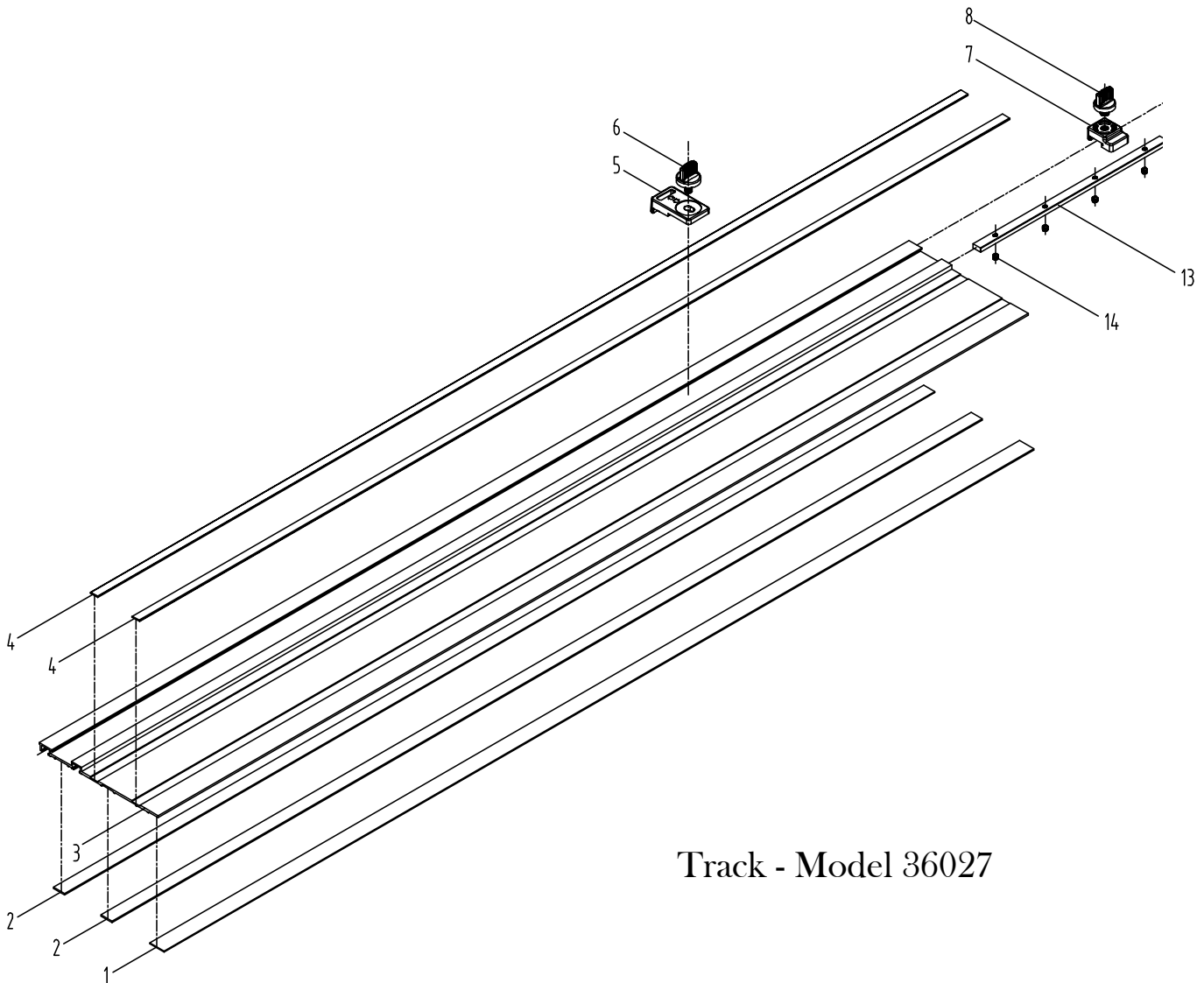

Track - Model 36027

EXPLODED VIEW AND PARTS LIST

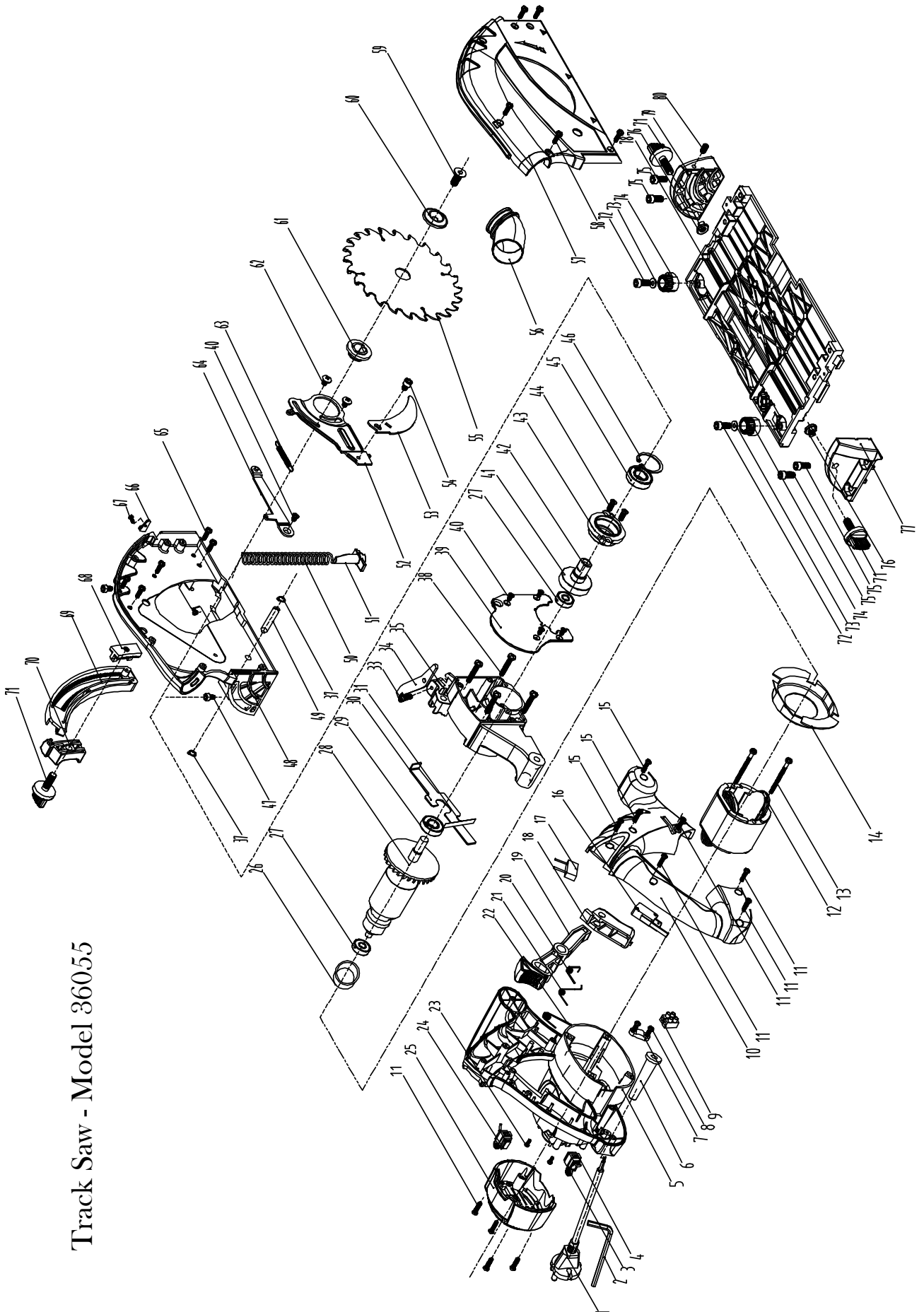

Track Saw - Model 36055

EXPLODED VIEW AND PARTS LIST

No.	Part No.	Description
1	36055-001	Power Cord
2	36055-002	Hexagon Stud Wrench
3	36055-003	Carbon Brush Spring
4	36055-004	Carbon Brush Holder
5	36055-005	Motor Housing
6	36055-006	Rubber Protection Tube
7	36055-007	Cord Pressing Plate
8	36055-008	Screw 4.2x13
9	36055-009	Attachment
10	36055-010	Handle
11	36055-011	Screw 7x24
12	36055-012	Stator
13	36055-013	Screw
14	36055-014	Front Cover
15	36055-015	Rubber Gil
16	36055-016	Switch
17	36055-017	Capacitor
18	36055-018	Switch Button
19	36055-019	Locking Button
20	36055-020	Reset Spring
21	36055-021	Locking Button Spring
22	36055-022	Switch Button Spring
24	36055-024	Carbon Brushes (2)
25	36055-025	Back Cover
26	36055-026	Rubber Sleeve for Bearing
27	36055-027	Bearing
28	36055-028	Rotor
29	36055-029	Bearing
30	36055-030	Shaft Locking Part
31	36055-031	Spring for Lock Bar
33	36055-033	Head Screw
34	36055-034	Cutting Lock
35	36055-035	Gear Box
38	36055-038	Screw
39	36055-039	Gear Box Cover
40	36055-040	Flathead Countersunk Screws
41-42	36055-041	Shaft
43	36055-043	Bearing Cover
44	36055-044	Screw
45	36055-045	Bearing 6002
46	36055-046	Retaining Ring for Shaft
47	36055-047	Screw

No.	Part No.	Description
48	36055-048	Frame
49	36055-049	Pivot Pin
50	36055-050	Spring
51	36055-051	Spring Holder
52	36055-052	Riving Knife Holder
53	36055-053	Riving Knife
54	36055-054	Head Screw
55	36055-055	Blade
56	36055-056	Dust Connector
57	36055-057	Frame Cover
58	36055-058	Screw
59	36055-059	Countersunk Screw
60	36055-060	Outer Saw Blade Flange
61	36055-061	Inner Saw Blade Flange
62	36055-062	Screw
63	36055-063	Spring
64	36055-064	Connecting Rod - Riving Knife
66	36055-066	Pointer
68	36055-068	Guider
69	36055-069	Depth Scale
70	36055-070	Pressing Part
71	36055-071	Knob
72	36055-072	Cylinder Head Screw M6x12
73	36055-073	Washer
74	36055-074	Knob
75	36055-075	Head Screw
76	36055-076	Knob
77	36055-077	Left Tilting Guider
78	36055-078	Bottom Plate
79	36055-079	Right Tilting Guider
80	36055-080	Grub Screw for 45 Degree Stop
NP	36053C	Clamp (sold separately)

TRACK EXPLODED VIEW (36027)		
No.	Part No.	Description
1	36027-001	Bottom Rubber Strip
2	36027-002	Bottom Foam Strip
3	36027-003	Guiding Rail
4	36027-004	Top Plastic Strip
5-6	36027-005	Stabilizer
7-8	36027-007	Stopper
13-14	36027-013	Track Adaptor

LIMITED TWO YEARS WARRANTY

WEN Products is committed to building tools that are dependable for years. Our warranties are consistent with this commitment and our dedication to quality.

LIMITED WARRANTY OF WEN CONSUMER POWER TOOLS PRODUCTS FOR HOME USE

GREAT LAKES TECHNOLOGIES, LLC (“Seller”) warrants to the original purchaser only, that all WEN consumer power tools will be free from defects in material or workmanship for a period of two (2) years from date of purchase. Ninety days for all WEN products, if the tool is used for professional use.

SELLER’S SOLE OBLIGATION AND YOUR EXCLUSIVE REMEDY under this Limited Warranty and, to the extent permitted by law, any warranty or condition implied by law, shall be the repair or replacement of parts, without charge, which are defective in material or workmanship and which have not been misused, carelessly handled, or misrepaired by persons other than Seller or Authorized Service Center. To make a claim under this Limited Warranty, you must make sure to keep a copy of your proof of purchase that clearly defines the Date of Purchase (month and year) and the Place of Purchase. Place of purchase must be a direct vendor of Great Lakes Technologies, LLC. Third party vendors such as garage sales, pawn shops, resale shops, or any other secondhand merchant void the warranty included with this product. Contact techsupport@wenproducts.com or 1-800-232-1195 to make arrangements for repairs and transportation.

When returning a product for warranty service, the shipping charges must be prepaid by the purchaser. The product must be shipped in its original container (or an equivalent), properly packed to withstand the hazards of shipment. The product must be fully insured with a copy of the warranty card and/or the proof of purchase enclosed. There must also be a description of the problem in order to help our repairs department diagnose and fix the issue. Repairs will be made and the product will be returned and shipped back to the purchaser at no charge.

THIS LIMITED WARRANTY DOES NOT APPLY TO ACCESSORY ITEMS THAT WEAR OUT FROM REGULAR USAGE OVER TIME INCLUDING BELTS, BRUSHES, BLADES, ETC.

ANY IMPLIED WARRANTIES SHALL BE LIMITED IN DURATION TO TWO (2) YEARS FROM DATE OF PURCHASE. SOME STATES IN THE U.S., SOME CANADIAN PROVINCES DO NOT ALLOW LIMITATIONS ON HOW LONG AN IMPLIED WARRANTY LASTS, SO THE ABOVE LIMITATION MAY NOT APPLY TO YOU.

IN NO EVENT SHALL SELLER BE LIABLE FOR ANY INCIDENTAL OR CONSEQUENTIAL DAMAGES (INCLUDING BUT NOT LIMITED TO LIABILITY FOR LOSS OF PROFITS) ARISING FROM THE SALE OR USE OF THIS PRODUCT. SOME STATES IN THE U.S. AND SOME CANADIAN PROVINCES DO NOT ALLOW THE EXCLUSION OR LIMITATION OF INCIDENTAL OR CONSEQUENTIAL DAMAGES, SO THE ABOVE LIMITATION OR EXCLUSION MAY NOT APPLY TO YOU.

THIS LIMITED WARRANTY GIVES YOU SPECIFIC LEGAL RIGHTS, AND YOU MAY ALSO HAVE OTHER RIGHTS WHICH VARY FROM STATE TO STATE IN THE U.S., PROVINCE TO PROVINCE IN CANADA AND FROM COUNTRY TO COUNTRY.

THIS LIMITED WARRANTY APPLIES ONLY TO PORTABLE ELECTRIC TOOLS, BENCH POWER TOOLS, OUTDOOR POWER EQUIPMENT AND PNEUMATIC TOOLS SOLD WITHIN THE UNITED STATES OF AMERICA, CANADA AND THE COMMONWEALTH OF PUERTO RICO. FOR WARRANTY COVERAGE WITHIN OTHER COUNTRIES, CONTACT THE WEN CUSTOMER SUPPORT LINE.