

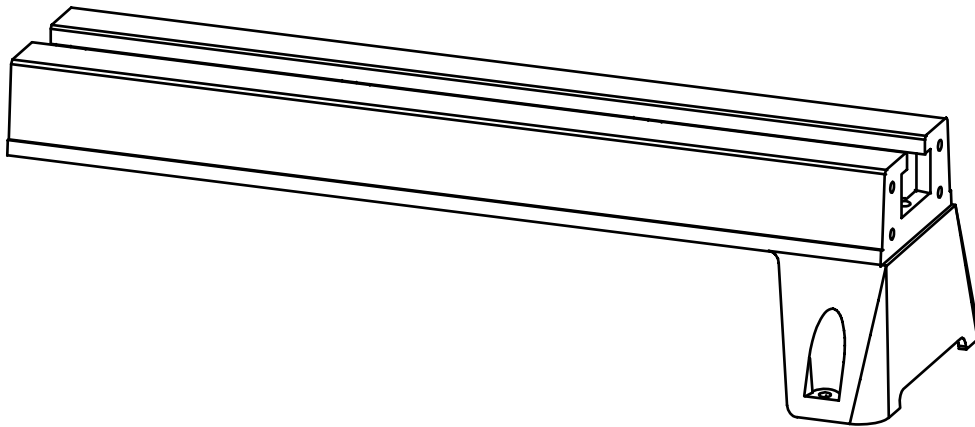

12 IN. WOOD LATHE TABLE EXTENSION



Model # 3427EX1
bit.ly/wenvideo

IMPORTANT:

Your new tool has been engineered and manufactured to WEN's highest standards for dependability, ease of operation, and operator safety. When properly cared for, this product will supply you years of rugged, trouble-free performance. Pay close attention to the rules for safe operation, warnings, and cautions. If you use your tool properly and for intended purpose, you will enjoy years of safe, reliable service.



NEED HELP? CONTACT US!

Have product questions? Need technical support?
Please feel free to contact us at:

 **800-232-1195** (M-F 8AM-5PM CST)

 techsupport@wenproducts.com

 WENPRODUCTS.COM

TABLE OF CONTENTS

Technical Data	2
General Safety Rules	3
Specific Safety Rules For Wood Lathes	4
Electrical Information	5
Assembly	6
Exploded View & Parts List	6
Warranty	7

TECHNICAL DATA

Model Number:	3427EX1
Fits:	WEN 3427 12-Inch Variable Speed Wood Lathe
Length of Extension:	23.5 inches
Length of Lathe w/ Extension:	41.5 inches
Dimensions:	23.5 x 8 x 7 in.
Weight:	17.5 lbs.

ASSEMBLY

INSTALLING BED EXTENSION

1. Fit the bed extension (3) to the bed using four socket head screws and four flat washers.
2. Remove the end stop screw (2) from the bed and assemble it onto the bed extension.
3. Make sure the tail stock (1) slides freely across the connection point.

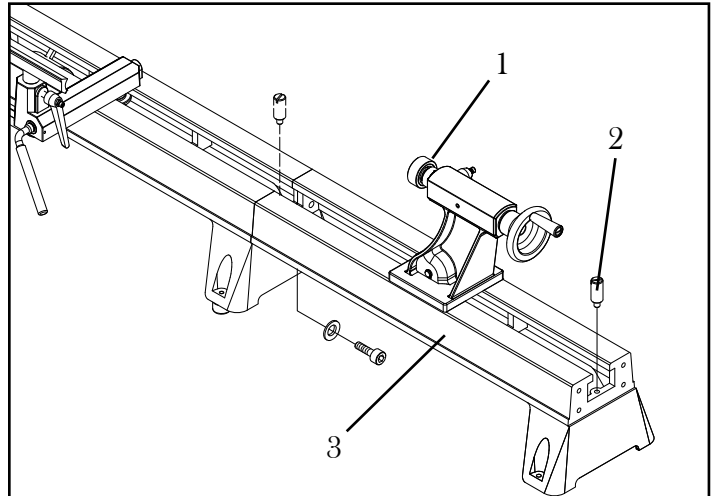

MOUNTING THE LATHE TO A BENCHTOP

For effective and safe operation, the lathe should be mounted to a bench table, removing the feet and using the six threaded holes in its base to bolt it to the surface.

EXPLODED VIEW AND PARTS LIST

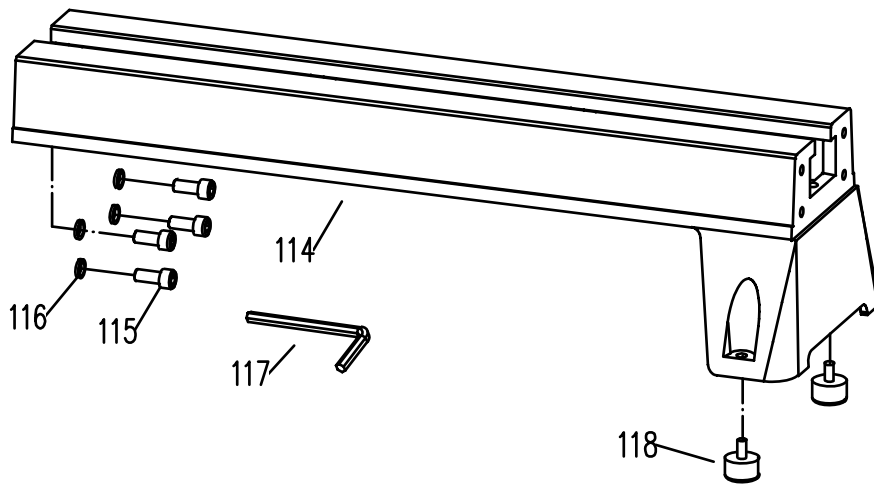

No	PART NUMBER	DESCRIPTION	QTY
114	3427EX1-114	Bed Extension	1
115	3427EX1-115	Socket Head Screw	4
116	3427EX1-116	Washer	4
117	3427EX1-117	Hex Wrench	1
118	3427EX1-118	Foot	2

THANKS FOR
REMEMBERING

