

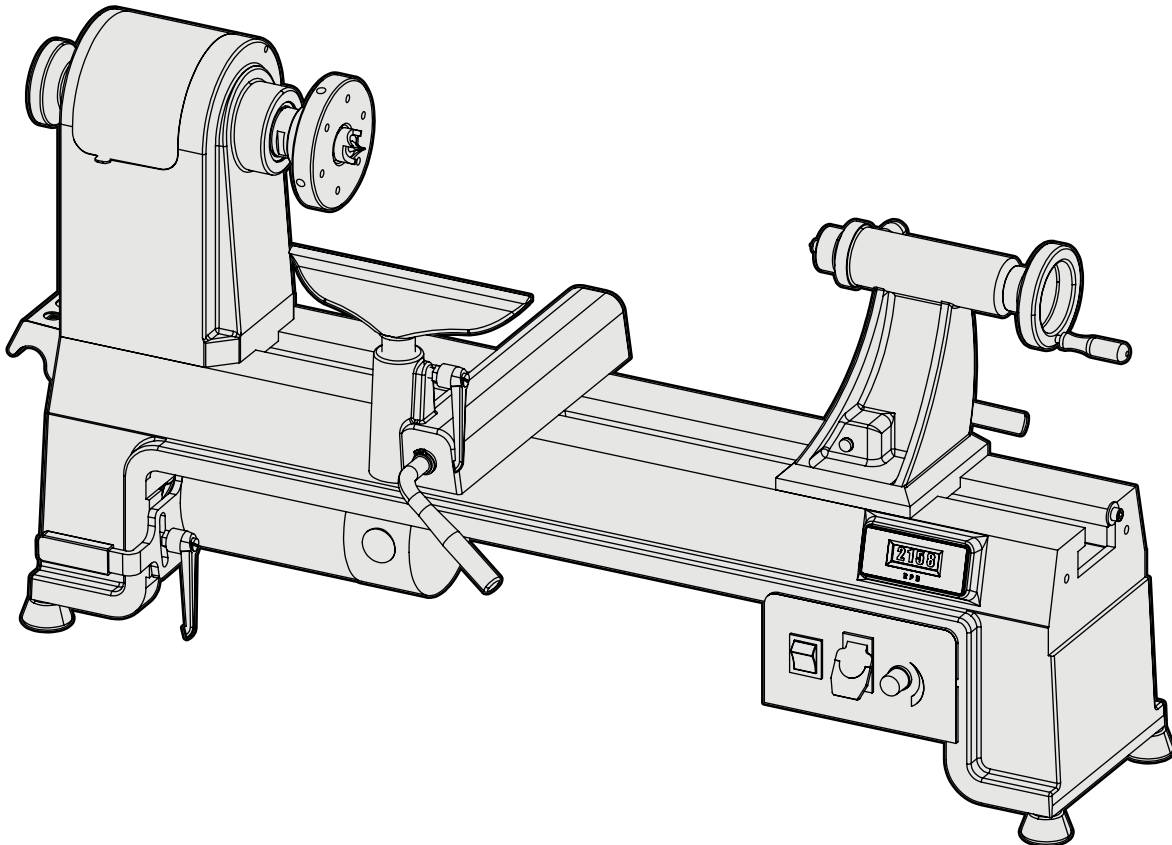

MODEL 34035

14" x 20" VARIABLE SPEED WOOD LATHE

Instruction Manual



NEED HELP? CONTACT US!

Have product questions? Need technical support? Please feel free to contact us:



1-800-232-1195 (M-F 8AM-5PM CST)



TECHSUPPORT@WENPRODUCTS.COM

IMPORTANT: Your new tool has been engineered and manufactured to WEN's highest standards for dependability, ease of operation, and operator safety. When properly cared for, this product will supply you years of rugged, trouble-free performance. Pay close attention to the rules for safe operation, warnings, and cautions. If you use your tool properly and for its intended purpose, you will enjoy years of safe, reliable service.

For replacement parts and the most up-to-date instruction manuals, visit ***WENPRODUCTS.COM***

CONTENTS

WELCOME	3
Introduction	3
Specifications.....	3
SAFETY	4
General Safety Rules.....	4
Specific Rules for Your Lathe.....	6
Electrical Information.....	8
BEFORE OPERATING	9
Unpacking & Transportation	9
Know Your Lathe.....	10
Assembly & Adjustments.....	10
OPERATION & MAINTENANCE	12
Operation	15
Troubleshooting Guide.....	20
Maintenance.....	22
Exploded View & Parts List.....	23
Warranty Statement	25

To purchase accessories for your tool, visit ***WENPRODUCTS.COM***

Lathe Chuck (Models LA4444, LA4275, LA4374)

Drive & Live Center Kit (Model LA0009)

Tailstock Live Center (Model LA1158)

Crown Revolving Live Center (Model LA1334)

Chisels (Models CH11, CH14, CH4704)

Lathe Stand (Model LA8800)

Extension Bed (Model 34035EX)

INTRODUCTION

Thanks for purchasing a WEN Lathe. We know you are excited to put your tool to work, but first, please take a moment to read through the manual. Safe operation of this tool requires that you read and understand this operator's manual and all the labels affixed to the tool. This manual provides information regarding potential safety concerns, as well as helpful assembly and operating instructions for your tool.

 **SAFETY ALERT SYMBOL:** Indicates danger, warning, or caution. The safety symbols and the explanations with them deserve your careful attention and understanding. Always follow the safety precautions to reduce the risk of fire, electric shock or personal injury. However, please note that these instructions and warnings are not substitutes for proper accident prevention measures.

NOTE: The following safety information is not meant to cover all possible conditions and situations that may occur. WEN reserves the right to change this product and specifications at any time without prior notice.

At WEN, we are continuously improving our products. If you find that your tool does not exactly match this manual, please visit wenproducts.com for the most up-to-date manual or contact our customer service at **1-800-232-1195**.

Keep this manual available to all users during the entire life of the tool and review it frequently to maximize safety for both yourself and others.

SPECIFICATIONS

Model Number	34035
Motor	120V, 60 Hz, 6A
Swing Over Bed	14 inches (355mm)
Distance Between Centers	20 inches (510 mm)
Center Height	7 inches (178mm)
Spindle Speeds	250-720, 600-1700, 1200-3550 RPM
Spindle Taper	MT2
Spindle Thread	1 inch x 8 TPI
Tailstock Taper	MT2
Quill Travel	3-1/2 inches
Tool Rest Length	8 inches
Face Plate Diameter	4 inches (102mm)
Weight	125.7 lbs
Product Dimensions	38 x 11.8 x 22.6 inches

GENERAL SAFETY RULES

⚠ WARNING! Read all safety warnings and all instructions. Failure to follow the warnings and instructions may result in electric shock, fire and/or serious injury.

Safety is a combination of common sense, staying alert and knowing how your item works. The term “power tool” in the warnings refers to your mains-operated (corded) power tool or battery-operated (cordless) power tool.

SAVE THESE SAFETY INSTRUCTIONS.

WORK AREA SAFETY

- 1. Keep work area clean and well lit.** Cluttered or dark areas invite accidents.
- 2. Do not operate power tools in explosive atmospheres, such as in the presence of flammable liquids, gases or dust.** Power tools create sparks which may ignite the dust or fumes.
- 3. Keep children and bystanders away while operating a power tool.** Distractions can cause you to lose control.

ELECTRICAL SAFETY

- 1. Power tool plugs must match the outlet. Never modify the plug in any way. Do not use any adapter plugs with earthed (grounded) power tools.** Unmodified plugs and matching outlets will reduce risk of electric shock.
- 2. Avoid body contact with earthed or grounded surfaces such as pipes, radiators, ranges and refrigerators.** There is an increased risk of electric shock if your body is earthed or grounded.
- 3. Do not expose power tools to rain or wet conditions.** Water entering a power tool will increase the risk of electric shock.
- 4. Do not abuse the cord. Never use the cord for carrying, pulling or unplugging the power tool. Keep cord away from heat, oil, sharp edges or moving parts.** Damaged or entangled cords increase the risk of electric shock.
- 5. When operating a power tool outdoors, use an extension cord suitable for outdoor use.** Use of a cord suitable for outdoor use reduces the risk of electric shock.

6. If operating a power tool in a damp location is unavoidable, use a ground fault circuit interrupter (GFCI) protected supply. Use of a GFCI reduces the risk of electric shock.

PERSONAL SAFETY

- 1. Stay alert, watch what you are doing and use common sense when operating a power tool. Do not use a power tool while you are tired or under the influence of drugs, alcohol or medication.** A moment of inattention while operating power tools may result in serious personal injury.
- 2. Use personal protective equipment. Always wear eye protection.** Protective equipment such as a respiratory mask, non-skid safety shoes and hearing protection used for appropriate conditions will reduce the risk of personal injury.
- 3. Prevent unintentional starting. Ensure the switch is in the off-position before connecting to power source and/or battery pack, picking up or carrying the tool.** Carrying power tools with your finger on the switch or energizing power tools that have the switch on invites accidents.
- 4. Remove any adjusting key or wrench before turning the power tool on.** A wrench or a key left attached to a rotating part of the power tool may result in personal injury.
- 5. Do not overreach. Keep proper footing and balance at all times.** This enables better control of the power tool in unexpected situations.
- 6. Dress properly. Do not wear loose clothing or jewelry. Keep your hair and clothing away from moving parts.** Loose clothes, jewelry or long hair can be caught in moving parts.

GENERAL SAFETY RULES

⚠ WARNING! Read all safety warnings and all instructions. Failure to follow the warnings and instructions may result in electric shock, fire and/or serious injury.

Safety is a combination of common sense, staying alert and knowing how your item works. The term “power tool” in the warnings refers to your mains-operated (corded) power tool or battery-operated (cordless) power tool.

SAVE THESE SAFETY INSTRUCTIONS.

7. If devices are provided for the connection of dust extraction and collection facilities, ensure these are connected and properly used. Use of dust collection can reduce dust-related hazards.

POWER TOOL USE AND CARE

1. Do not force the power tool. Use the correct power tool for your application. The correct power tool will do the job better and safer at the rate for which it was designed.

2. Do not use the power tool if the switch does not turn it on and off. Any power tool that cannot be controlled with the switch is dangerous and must be repaired.

3. Disconnect the plug from the power source and/or the battery pack from the power tool before making any adjustments, changing accessories, or storing power tools. Such preventive safety measures reduce the risk of starting the power tool accidentally.

4. Store idle power tools out of the reach of children and do not allow persons unfamiliar with the power tool or these instructions to operate the power tool. Power tools are dangerous in the hands of untrained users.

5. Maintain power tools. Check for misalignment or binding of moving parts, breakage of parts and any other condition that may affect the power tool's operation. If damaged, have the power tool repaired before use. Many accidents are caused by poorly maintained power tools.

6. Keep cutting tools sharp and clean. Properly maintained cutting tools with sharp cutting edges are less likely to bind and are easier to control.

7. Use the power tool, accessories and tool bits, etc. in accordance with these instructions, taking into account the working conditions and the work to be performed. Use of the power tool for operations different from those intended could result in a hazardous situation.

8. Use clamps to secure your workpiece to a stable surface. Holding a workpiece by hand or using your body to support it may lead to loss of control.

9. KEEP GUARDS IN PLACE and in working order.

SERVICE

1. Have your power tool serviced by a qualified repair person using only identical replacement parts. This will ensure that the safety of the power tool is maintained.

CALIFORNIA PROPOSITION 65 WARNING

Some dust created by power sanding, sawing, grinding, drilling, and other construction activities may contain chemicals, including lead, known to the State of California to cause cancer, birth defects, or other reproductive harm. Wash hands after handling. Some examples of these chemicals are:

- Lead from lead-based paints.
- Crystalline silica from bricks, cement, and other masonry products.
- Arsenic and chromium from chemically treated lumber.

Your risk from these exposures varies depending on how often you do this type of work. To reduce your exposure to these chemicals, work in a well-ventilated area with approved safety equipment such as dust masks specially designed to filter out microscopic particles.

SPECIFIC RULES FOR YOUR LATHE

 **WARNING!** Do not operate the power tool until you have read and understood the following instructions and the warning labels.

TURNING SAFETY

1. This lathe is designed and intended for use by properly trained and experienced personnel only. If you are not familiar with the proper and safe operation of a lathe, do not use it until proper training and knowledge have been acquired.
2. **DO NOT** wear loose clothing or jewelry. Keep your hair, clothing and gloves away from moving parts. Loose clothes, jewelry or long hair can be caught in the spinning tool.
3. Select the right tool for your task at hand. Make sure all tools, chisels and accessories are sharp before using them. Do not use dull or damaged tools.
4. Select the appropriate speed for the task. Use slower speeds when starting on a workpiece. Allow the lathe to ramp up to the operating speed before engaging carving tools.
5. Check the workpiece carefully for splits, knots, nails, or other obstructions. These types of blemishes may cause a safety hazard during turning.
6. If gluing up a workpiece for turning, always use a high quality glue that meets the needs of the particular workpiece to prevent the workpiece from falling off during operation.
7. Rough cut the workpiece as close as possible to the finished shape before mounting it on the lathe.

PERSONAL SAFETY

1. Operate in a well ventilated area. Keep the floor area around the lathe level and free of slippery substances or other tripping hazards.
2. Wear ANSI-approved safety goggles to protect your eyes from sawdust. Use hearing protection to protect yourself from hearing loss.
3. People with pacemakers should consult their physician(s) before use. Electromagnetic fields in close proximity to pacemakers could cause pacemaker interference or pacemaker failure.
4. Sawdust is harmful to your health. Use NIOSH-approved dust masks or other respiratory protection during operation and cleaning.
5. Always turn off and unplug the lathe before making any adjustments or repair tasks. Never adjust the lathe or the workpiece while the lathe is running.
6. Do not use to cut metal, logs, tree limbs, or uneven lumber. Inspect the workpiece and remove all nails and other embedded objects prior to starting work.
7. Wet lumber, green (unseasoned) lumber, and pressure treated lumber all have an increased potential for kickback and should only be cut with a blade specifically designed for that lumber type. Wear a NIOSH-approved respirator and have appropriate ventilation whenever cutting pressure treated lumber.

SPECIFIC RULES FOR YOUR LATHE

 **WARNING!** Do not operate the power tool until you have read and understood the following instructions and the warning labels.

PREPARING THE LATHE

1. When transporting the lathe, carry it by the base or handles. Never carry the device by its guards or its accessories.
2. Examine the lathe for any damaged or missing parts. Replace or repair damaged parts before operation. Periodically check that all nuts, bolts and other fasteners are properly tightened.

SECURE YOUR WORKPIECE

1. Securely fasten the workpiece to the faceplate prior to faceplate turning. Use the appropriate size faceplate to properly support the workpiece. Do not let the screw fasteners interfere with the turning tool at the finished dimension of the workpiece.
2. When turning between centers, make sure the headstock and tailstock are tight and snug against the workpiece.
3. Never drive the workpiece into the spur center while the spur center is in the headstock. Set the drive center into the work piece with a soft mallet prior to installing it on the headstock.

DURING CUTTING OPERATIONS

1. Make sure the spindle lock is **DISENGAGED** before starting the lathe. Never start the lathe with the spindle lock in the locked position.
2. Rotate the workpiece by hand to check clearance with the tool rest before turning the machine on.

3. Ensure hands are away from the turning area.
4. If you are interrupted when operating the lathe, complete the process and switch the lathe **OFF** before looking up.
5. Do not use the lathe unless all guards are in place. Do not operate with any guard disabled, damaged, or removed. Moving guards must move freely and close instantly.
6. Turn on the lathe and let it reach full speed, then slowly slide your tool into the workpiece. This will help produce safer and cleaner cuts.
7. Never apply coolants, water, or other liquids to a spinning workpiece.
8. Turn off the lathe and wait for your workpiece to stop rotating before moving workpiece or changing settings. Never stop a rotating workpiece with your hand.
9. Turn off the machine before changing the spindle rotation direction.
10. Turn off and unplug the machine before doing any cleaning or maintenance. Use a brush or compressed air to remove chips or debris. Never use your hands to remove excess material and debris.

ELECTRICAL INFORMATION

GROUNDING INSTRUCTIONS

In the event of a malfunction or breakdown, grounding provides the path of least resistance for an electric current and reduces the risk of electric shock. This tool is equipped with an electric cord that has an equipment grounding conductor and a grounding plug. The plug **MUST** be plugged into a matching outlet that is properly installed and grounded in accordance with ALL local codes and ordinances.

1. Do not modify the plug provided. If it will not fit the outlet, have the proper outlet installed by a licensed electrician.

2. Improper connection of the equipment grounding conductor can result in electric shock. The conductor with the green insulation (with or without yellow stripes) is the equipment grounding conductor. If repair or replacement of the electric cord or plug is necessary, **DO NOT** connect the equipment grounding conductor to a live terminal.

3. Check with a licensed electrician or service personnel if you do not completely understand the grounding instructions or whether the tool is properly grounded.

4. Use only three-wire extension cords that have three-pronged plugs and outlets that accept the tool's plug (INSERT CR). Repair or replace a damaged or worn cord immediately.

CAUTION! In all cases, make certain the outlet in question is properly grounded. If you are not sure, have a licensed electrician check the outlet.

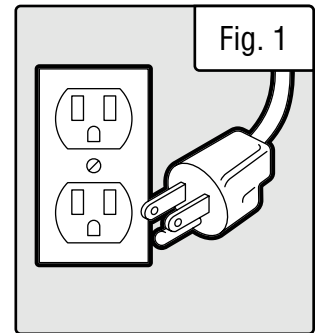

GUIDELINES AND RECOMMENDATIONS FOR EXTENSION CORDS

When using an extension cord, be sure to use one heavy enough to carry the current your product will draw. An undersized cord will cause a drop in line voltage resulting in loss of power and overheating. The table below shows the correct size to be used according to cord length and ampere rating. When in doubt, use a heavier cord. The smaller the gauge number, the heavier the cord.

AMPERAGE	REQUIRED GAUGE FOR EXTENSION CORDS			
	25 ft.	50 ft.	100 ft.	150 ft.
6A	18 gauge	16 gauge	14 gauge	12 gauge

1. Examine extension cord before use. Make sure your extension cord is properly wired and in good condition. Always replace a damaged extension cord or have it repaired by a qualified person before using it.

2. Do not abuse extension cord. Do not pull on cord to disconnect from receptacle; always disconnect by pulling on plug. Disconnect the extension cord from the receptacle before disconnecting the product from the extension cord. Protect your extension cords from sharp objects, excessive heat and damp/wet areas.

3. Use a separate electrical circuit for your tool. This circuit must not be less than a 12-gauge wire and should be protected with a 15A time-delayed fuse. Before connecting the motor to the power line, make sure the switch is in the OFF position and the electric current is rated the same as the current stamped on the motor nameplate. Running at a lower voltage will damage the motor.

UNPACKING & TRANSPORTATION

⚠ WARNING! Do not plug in or turn on the tool until it is fully assembled according to the instructions. Failure to follow the safety instructions may result in serious personal injury.

UNPACKING

With the help of a friend or trustworthy foe, carefully remove the Lathe from the packaging. Make sure to take out all contents and accessories. Do not discard the packaging until everything is removed. Check the packing list below to make sure you have all of the parts and accessories. If any part is missing or broken, please contact our customer service at **1-800-232-1195** (M-F 8-5 CST), or email **techsupport@wenproducts.com**.

PACKING LIST

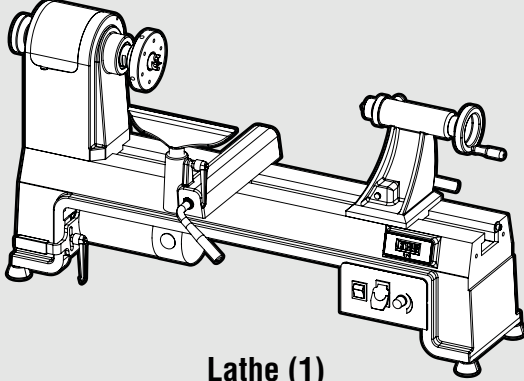
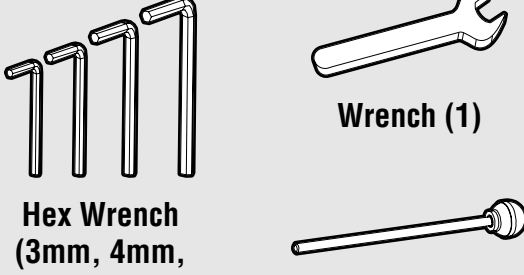
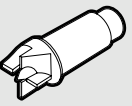
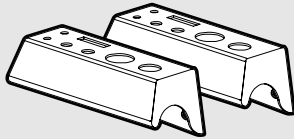
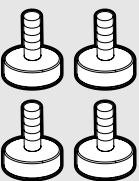
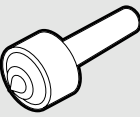
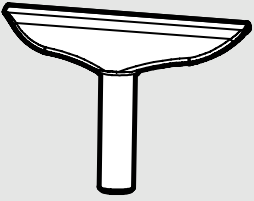
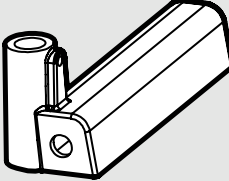
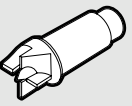
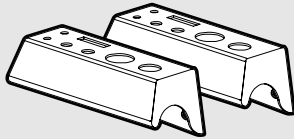
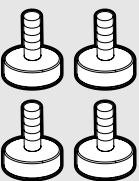
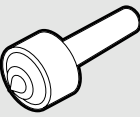
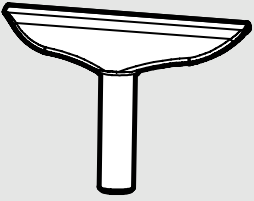
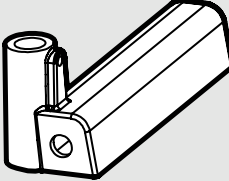
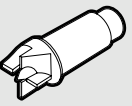
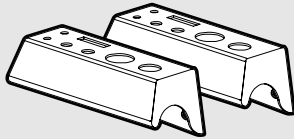
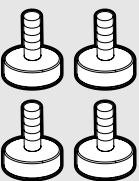
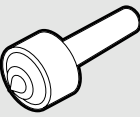
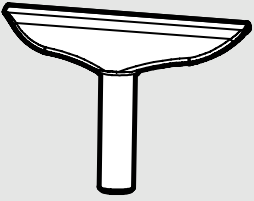
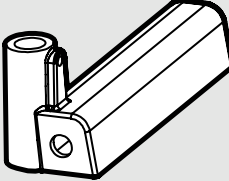
<p><i>Pre-Assembled</i></p>  <p>Lathe (1)</p>	<p><i>Tools</i></p>  <p>Hex Wrench (3mm, 4mm, 5mm, & 12mm)</p> <p>Wrench (1)</p> <p>Knockout Rod (1)</p>						
<p><i>Parts & Accessories</i></p> <table><tr><td data-bbox="103 1165 568 1365"><p>Spur Center for Headstock (MT2)</p></td><td data-bbox="568 1165 1055 1365"><p>Handle / Tool Holder (2)</p></td><td data-bbox="1055 1165 1515 1365"><p>Rubber Feet (4)</p></td></tr><tr><td data-bbox="103 1365 568 1726"><p>Live Center for Tailstock (MT2)</p></td><td data-bbox="568 1365 1055 1726"><p>Tool Rest (1)</p></td><td data-bbox="1055 1365 1515 1726"><p>Tool Rest Base Assembly (1)</p></td></tr></table>		 <p>Spur Center for Headstock (MT2)</p>	 <p>Handle / Tool Holder (2)</p>	 <p>Rubber Feet (4)</p>	 <p>Live Center for Tailstock (MT2)</p>	 <p>Tool Rest (1)</p>	 <p>Tool Rest Base Assembly (1)</p>
 <p>Spur Center for Headstock (MT2)</p>	 <p>Handle / Tool Holder (2)</p>	 <p>Rubber Feet (4)</p>					
 <p>Live Center for Tailstock (MT2)</p>	 <p>Tool Rest (1)</p>	 <p>Tool Rest Base Assembly (1)</p>					

TRANSPORTING

When transporting the lathe, carry it by the base or handles. Never carry the device by its guards or its accessories.

⚠ CAUTION! Your lathe is shipped with the spindle lock engaged. The spindle lock must be disengaged before use. Failure to do so can damage the machine. Refer to "Indexing/Spindle Lock" on p. 13 for more details.

KNOW YOUR LATHE

TOOL PURPOSE

Lathes are tools that turn your workpiece so you can cut, shape, and sand them. Refer to the following diagrams to become familiarized with all the parts and controls of your Lathe. The components will be referred to later in the manual for assembly and operation instructions.

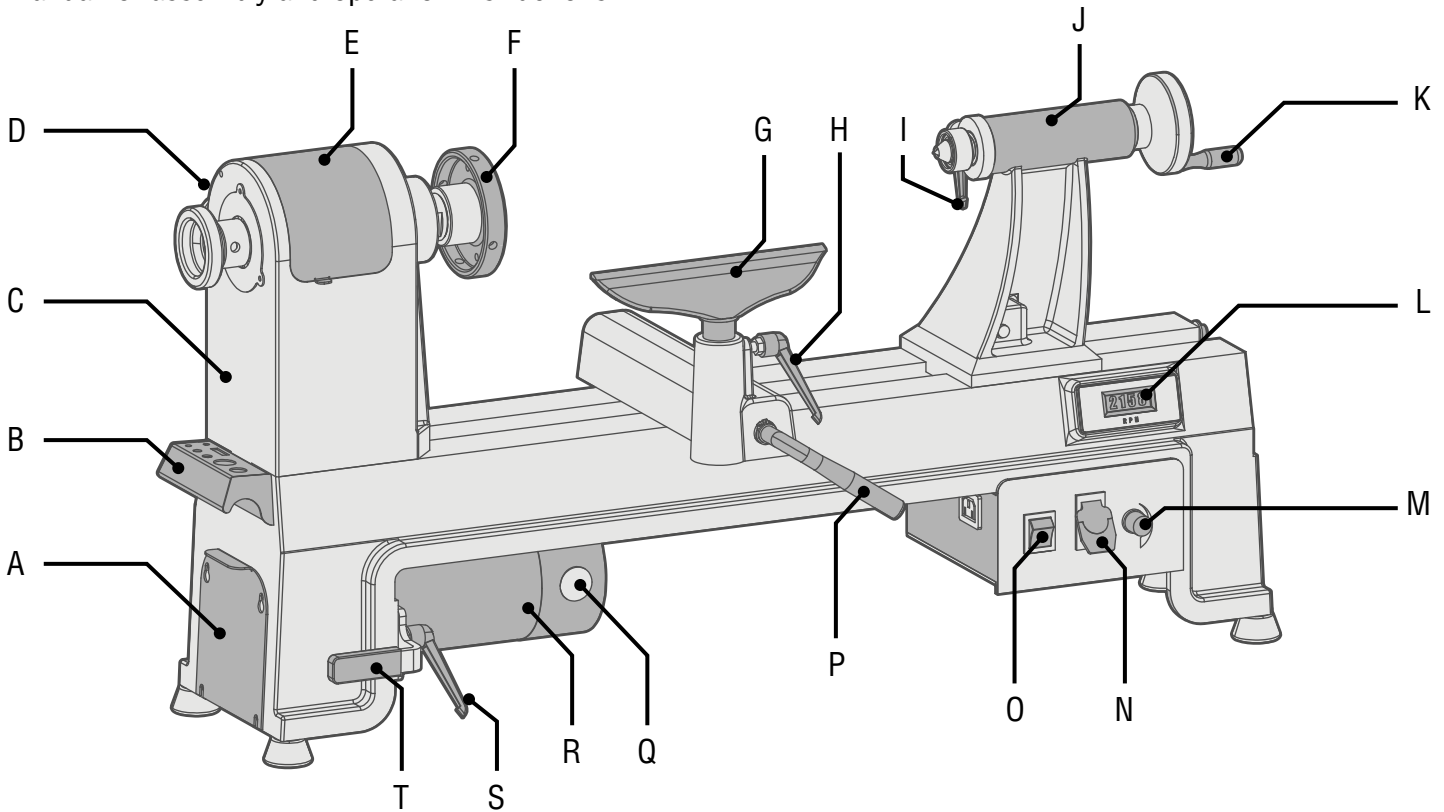

- | | | |
|---------------------------|----------------------------------|--------------------------------|
| A. Lower Belt Door | H. Tool Rest Locking Handle | O. Direction Switch |
| B. Handle/Tool Holder | I. Quill Locking Handle | P. Tool Rest Locking Lever |
| C. Headstock | J. Tailstock | Q. Carbon Brush Cap |
| D. Spindle Lock (on back) | K. Tailstock Handle | R. Motor |
| E. Upper Belt Door | L. Digital RPM Readout | S. Belt Tension Locking Handle |
| F. Face Plate | M. Speed Adjustment Knob | T. Belt Tension Handle |
| G. Tool Rest | N. ON/OFF Switch (w/ Safety Key) | |

ASSEMBLY & ADJUSTMENTS

INSTALL THE HANDLES (FIG. 2)

Your lathe comes with a handle kit that can be used for carrying the lathe, as well as for tool storage.

1. Use the included hex wrench to remove the two socket-head cap screws from either end of the lathe bed.

NOTE: Install the tool rest base (see p. 11) before installing the handle on the tailstock end of the bed.

2. Position the handle on the bed of the lathe. Align the mounting holes in the handle with those in the bed. Insert and tighten the two screws using the included hex wrench.

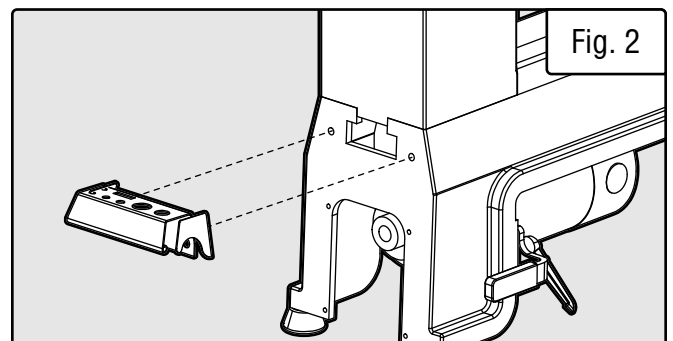

ASSEMBLY & ADJUSTMENTS

⚠ WARNING! Do not plug in or turn on the tool until it is fully assembled according to the instructions. Read through and become familiarized with the following procedures of handling and adjusting your tool. Failure to follow the safety instructions may result in serious personal injury.

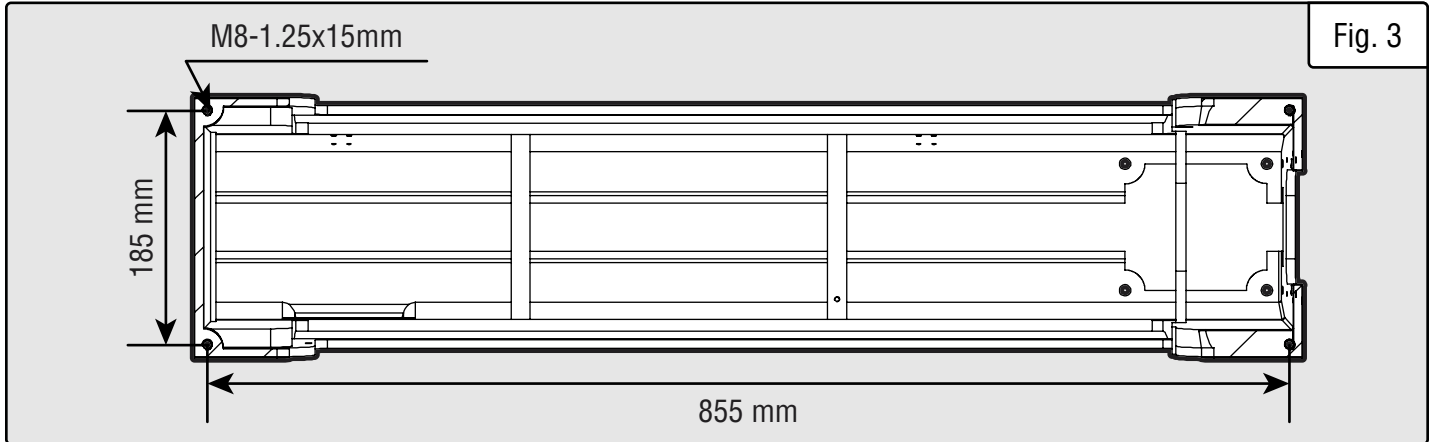

REMOVE THE ANTI-RUST COATING

Tool comes protected with a layer of anti-rust coating that needs to be cleaned off before use. Wipe off coating using an acetone-moistened cloth. Wear gloves to protect your hands. Apply a light coat of good-quality paste wax to the bed.

INSTALLING THE TOOL REST BASE

Before installing the handle on the tailstock end of the bed, you must install the tool rest base.

1. Loosen the tailstock locking lever (see p. 13) and remove the tailstock from the bed.
2. Slide the tool rest base onto the bed of the lathe.
3. Lock the tool rest base in place using the locking lever (Fig. 4 - 4) see "ADJUST THE TOOL REST" below).

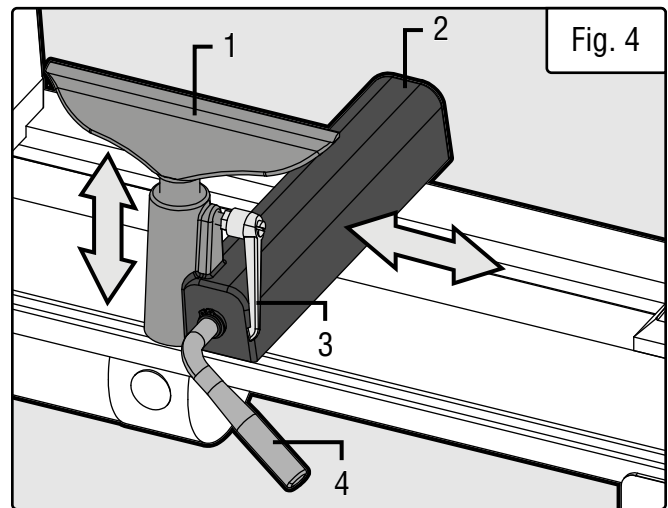

INSTALL THE TOOL REST

1. Loosen the tool rest locking handle (Fig. 4 - 3). The handle is spring-loaded and can be re-positioned as needed.
2. Insert the tool rest (Fig. 4 - 1) into the tool rest base (Fig. 4 - 2).
3. Tighten the tool rest locking handle.

MOUNT THE LATHE TO A BENCHTOP

For safe operation, securely mount the lathe onto a secure workbench to prevent movement during operation (mounting hardware is not included). Refer to Fig. 3 for your lathe's base dimensions and mounting hole threads.

NOTE: If the machine is not being mounted onto a benchtop, install the 4 rubber feet into the mounting holes.

ADJUST THE TOOL REST

You can adjust the position, height and angle of the tool rest assembly to suit your task at hand.

1. The tool rest locking lever (Fig. 4 - 4) locks the tool rest base (Fig. 4 - 2) in position. Loosen the lever to slide the tool rest base along the lathe bed. Tighten the lever firmly when the tool rest base is properly positioned.

NOTE: There is a nut on the underside of the tool rest base that needs to be adjusted periodically to enable the tool rest base locking lever to tighten properly.

2. The tool rest locking handle (Fig. 4 - 3) locks the tool rest (Fig. 4 - 1) in place. Loosen the handle to position the tool rest at the specific angle or height. Tighten the handle firmly when the tool rest is properly positioned.

NOTE: Adjust the height of the tool rest to just below the center of the workpiece, so that the tool will cut at the center of the workpiece (see page 16, step 7).

ASSEMBLY & ADJUSTMENTS

INSTALL THE FACE PLATE

When installing the face plate for turning bowls and plates, mount the workpiece onto the face plate prior to installing the face plate on the headstock (see "Mount The Workpiece Onto The Face Plate" on page 19).

To install the face plate:

1. Thread the face plate (Fig. 5 - 4) onto the headstock spindle by turning it clockwise as far as it will go, and then tighten the two set screws (Fig. 5 - 5) with a hex wrench.

2. Lock the spindle lock (Fig. 5 - 1) by engaging the knob in the deep groove (Fig. 6). Insert the knockout rod (Fig. 5 - 3) into a hole on the side of the face plate and use the wrench (Fig. 5 - 2) to fully tighten the face plate.

To remove the face plate:

1. Loosen the two face plate set screws (Fig. 5 - 5).

2. Lock the spindle lock (Fig. 5 - 1) and insert the knock out rod into the face plate side hole. Use the wrench to unscrew the face plate by turning it towards the operator.

INSTALL THE HEADSTOCK SPUR CENTER

Install the headstock spur center to turn workpiece between centers.

To install the spur center:

1. Make sure the mating surfaces of both the spur center and the headstock spindle are clean. You can use an acetone-moistened cloth to remove any other debris, oil, etc.

2. Drive the spur center into the workpiece using a rubber mallet or a piece of scrap wood (Fig. 7). See page 16, step 3 for detailed instructions.

⚠ CAUTION! Never drive the workpiece into the spur center while the spur center is in the headstock.

3. Push the spur center through the face plate into the headstock spindle.

To remove the spur center:

1. Hold the spur center (Fig. 8) to prevent it from falling. Use a rag to protect your hand from the sharp edges.

2. Insert the knockout rod (Fig. 8) through the spindle hole to tap out the spur center.

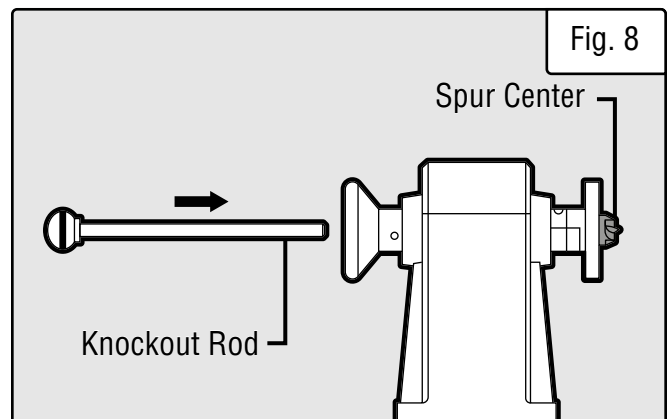
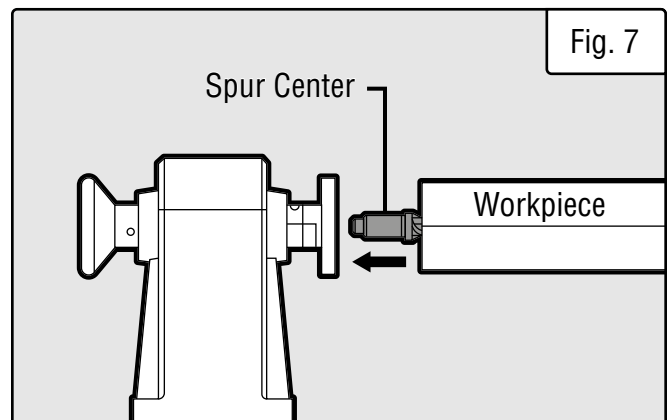
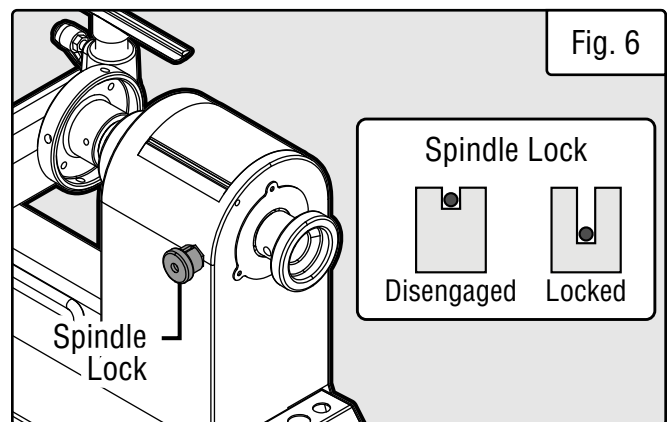
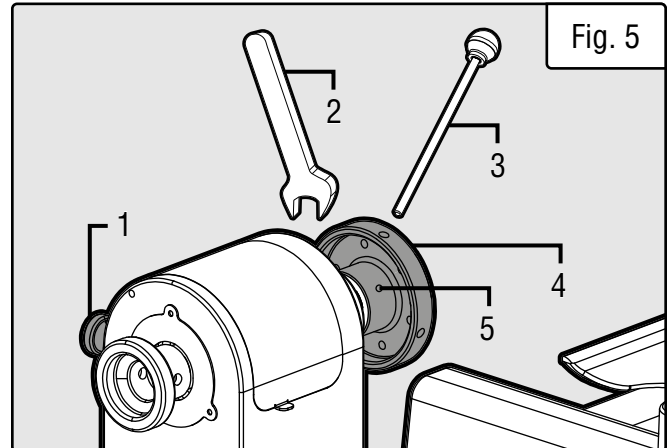

ASSEMBLY & ADJUSTMENTS

ADJUST THE TAILSTOCK

1. Loosen the tailstock locking lever (Fig. 9 - 3) and slide the tailstock along the lathe bed into the desired position. Retighten the locking lever.

2. Loosen the quill locking handle (Fig. 9 - 2) just enough to unlock the tailstock quill. Turn the handwheel (Fig. 9 - 1) clockwise to advance the quill and counterclockwise to retract the quill. Retighten the quill locking handle.

NOTE: There is a nut on the underside of the tool rest body that needs to be adjusted periodically to enable the tailstock locking lever to tighten properly.

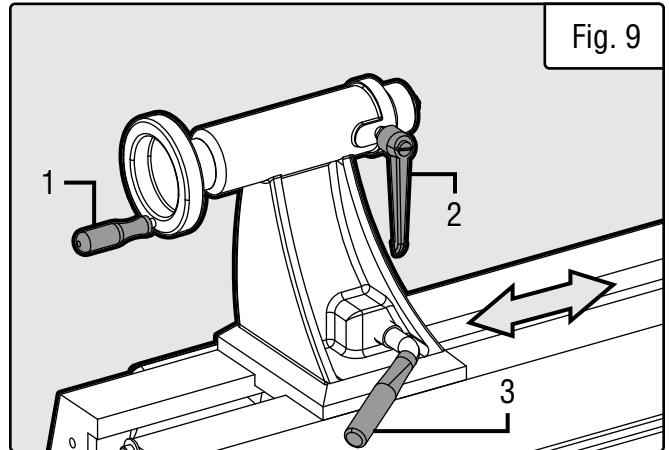

Fig. 9

INSTALL THE TAILSTOCK LIVE CENTER

To install the live center:

1. Rotate the tailstock handwheel (Fig. 10 - 3) clockwise a few times to advance the quill (Fig. 10 - 2) forward.

2. Make sure the mating surfaces are clean. Push the live center (Fig. 10 - 1) into the quill.

NOTE: If the tailstock quill gets fully retracted when the live center is mounted, it will dismount the live center. This is normal. Remount the live center by extending the tailstock quill approximately 0.5 inch and pushing the live center in place.

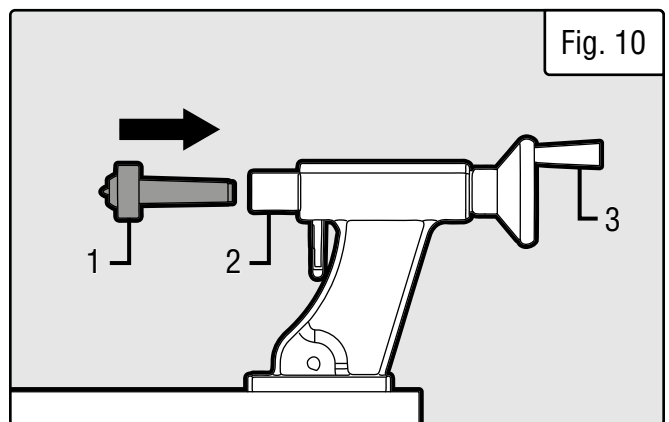

Fig. 10

To remove the live center:

1. Hold the live center (Fig. 11 - 2) to prevent it from falling. Use a rag to protect your hand from the sharp edges.

2. Rotate the handwheel (Fig. 11 - 1) counterclockwise to retract the quill until the live center is released from the quill.

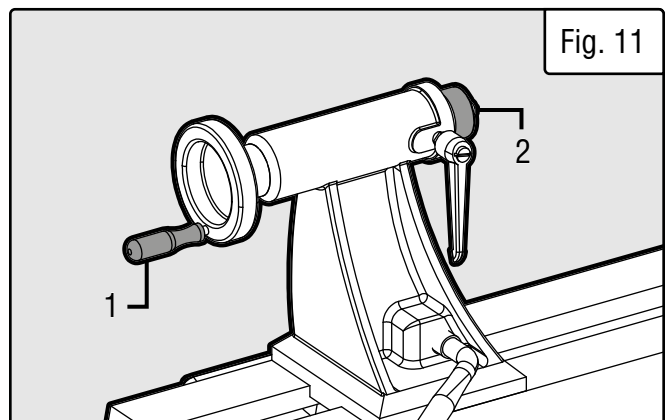

Fig. 11

INDEXING/SPINDLE LOCK

Indexing is used to create evenly spaced features around the circumference of the workpiece while keeping the spindle locked. There are 24 index positions (Fig. 11 - 1) in the spindle pulley, each 15° apart, to help you rotate the workpiece evenly for accurately spaced features. Place the spindle lock in the locked position (Fig. 6 on page 12) to help maintain the certain index point.

CAUTION! Make sure to DISENGAGE the spindle lock before starting the lathe again. Never start the lathe with the index pin engaged in the spindle pulley.

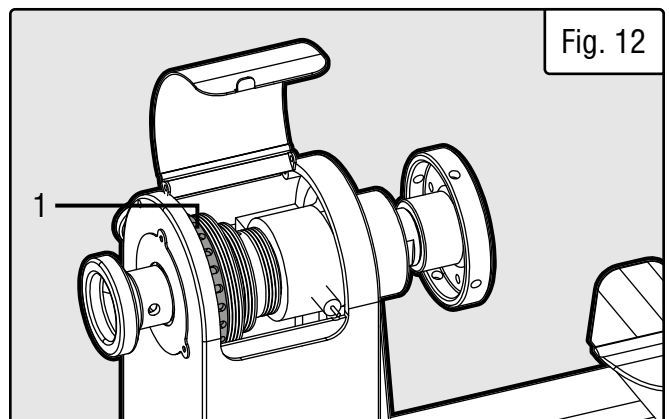

Fig. 12

ASSEMBLY & ADJUSTMENTS

ADJUST THE SPEED

Your variable speed lathe has three speed ranges: **Low** 250-720 RPM, **Medium** 600-1700 RPM, and **High** 1200-3550 RPM. Always start at slower speeds for rough cuts and larger workpieces. Use faster speeds for refined cuts and detailed work.

Set the suitable speed range for your operation by adjusting the belt position. Change the speed within a speed range using the speed adjustment knob. The speed will be displayed on the digital RPM readout (Fig. 17 - 1) on the front panel.

1. Turn off and disconnect the lathe.
2. Open the belt drive access panel (Fig. 13 - 1).
3. Loosen (but do not remove) the four screws holding the lower belt drive plate (Fig. 14) onto the left side of the headstock. Lift and remove the lower belt drive plate.
4. Loosen the motor tensioning locking handle (Fig. 15 - 2).

NOTE: The locking handle is spring-loaded. To re-position the handle, pull it outwards, place it in the desired position, and let go.

5. Pull upwards on the tensioning handle (Fig. 15 - 1) to relieve tension on the belt. It may help to wedge a piece of wood or other support under the tensioning handle to keep it in place while you adjust the belt position.

6. Adjust the belt's position on both the upper and lower drive pulleys to the desired speed range setting according to Fig. 16. Make sure the belt is vertically aligned on the upper and lower pulleys.

7. Lower the tensioning handle back to its original position, allowing the weight of the motor to place the belt under tension. Tighten the locking handle.

8. Replace the lower belt drive plate and tighten the screws. Lower the upper belt drive access panel.

9. Use the speed adjustment knob (Fig. 17 - 3) on the front panel to set the speed within your selected speed range. Use the direction switch (Fig. 17 - 2) to set the rotational direction. Do not change the direction when the tool is ON.

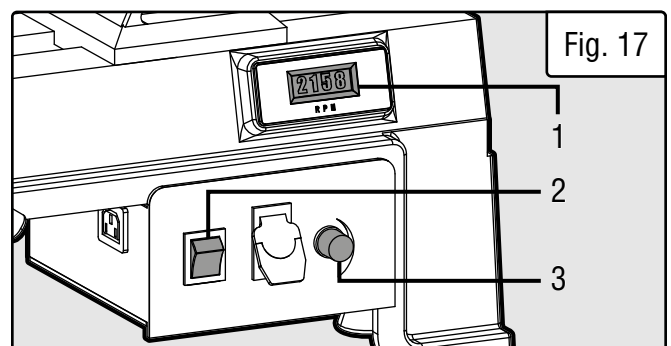
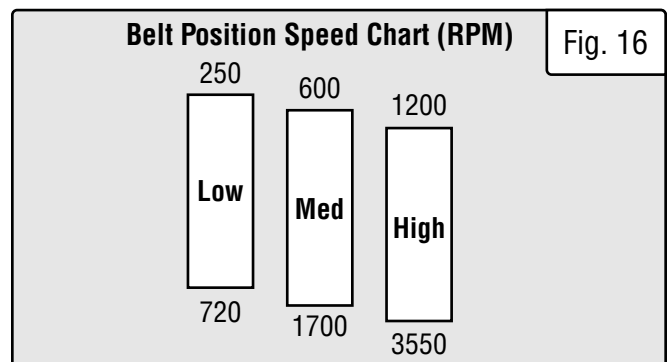
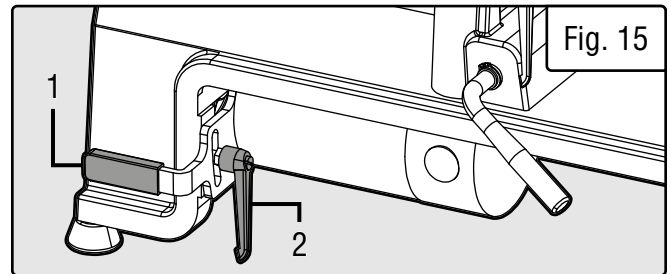
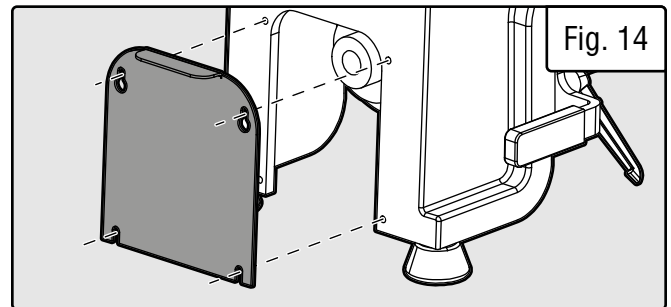
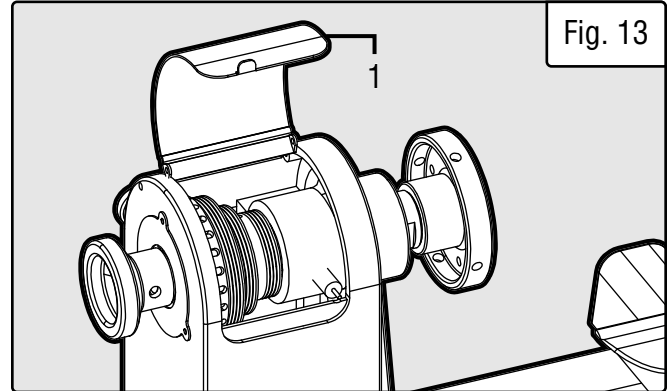

OPERATION

TURNING TOOLS

If possible, select only quality high-speed steel turning tools. High-speed steel tools hold an edge and last longer than ordinary carbon steel. As one becomes proficient in turning, a variety of specialty tools for specific applications can be acquired. The following tools provide the basics for most woodturning projects.

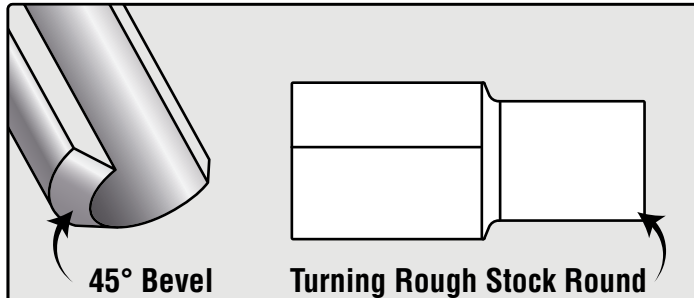

1. **ROUGHING GOUGE** - use this tool to shape square or out-of-round spindle-turning stock into a cylinder. This can also be used for creating shallow coves.

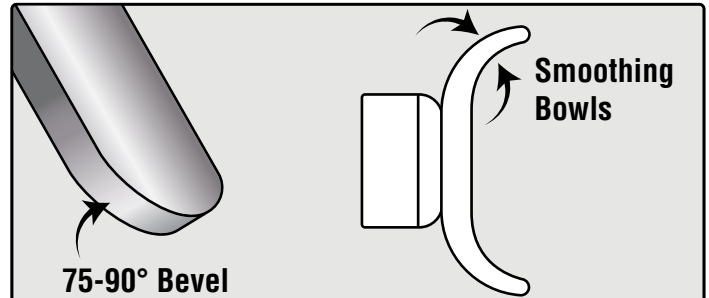

2. **ROUND NOSE SCRAPER** - use this tool for non-aggressive shaping of spindles and bowls and to smooth out surfaces without removing too much stock.

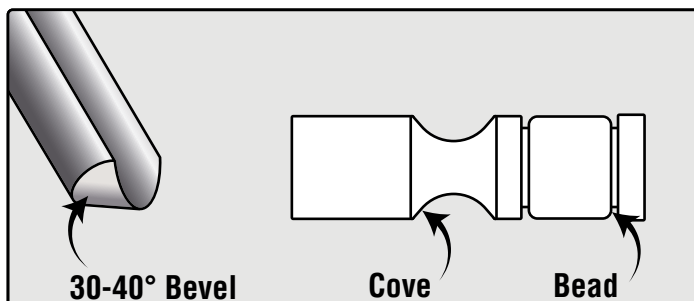

3. **SPINDLE GOUGE** - use this tool to cut coves, beads and free-form contours. It can also be used for producing shallow hollows on faceplate turnings.

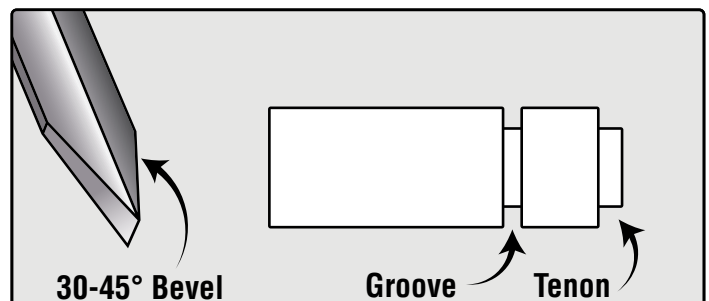

4. **PARTING TOOL** - use this tool to form grooves and tenons, and to remove stock. It can also be used for rolling small beads.

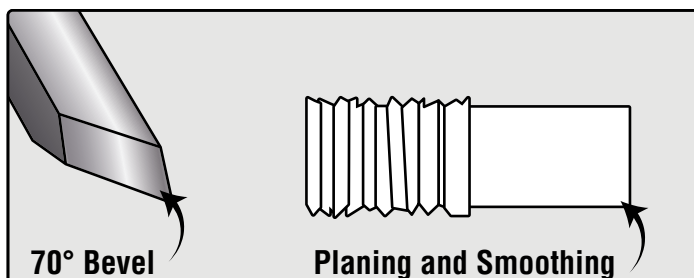

5. **SKEW CHISEL** - use this tool to even out high and low spots to shape cylinders. Vary the angle at which the tip meets the workpiece to change the aggressiveness of the cut. This can also be used for cutting beads and V-grooves.

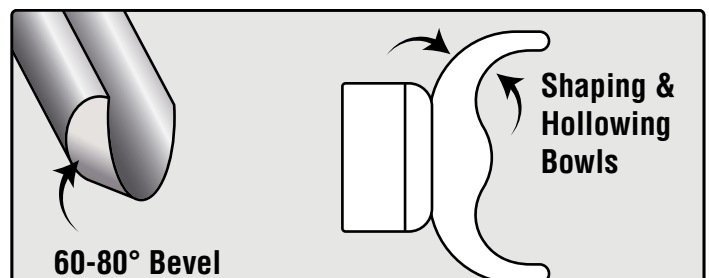

6. **BOWL GOUGE** - use this tool to cut external and internal profiles on faceplate-mounted stock, such as bowls and platters. It can also be used for creating ultra smooth cuts on bowls and spindles by using it as a shearing scraper.

CAUTION! Select the right tool for your task at hand. Make sure all tools, chisels and accessories are sharp before using them. DO NOT use dull or damaged tools.

OPERATION

⚠ WARNING! Do not plug in or turn on the tool until it is fully assembled according to the instructions. Read through and become familiarized with the following procedures of handling and adjusting your tool. Failure to follow the safety instructions may result in serious personal injury.

MOUNT THE WORKPIECE BETWEEN SPINDLES

Spindle turning takes place between the centers of the lathe, with the workpiece being held between the spur center in the headstock and the live center in the tailstock. The wood stock for spindle turning should be straight grained and free of cracks, knots, nails and other defects. Prepare the stock so that the end faces are approximately square shaped and vertical to the sides.

1. Using a combination square, locate and mark the center on both ends of the workpiece. Accuracy is not critical if you're turning full rounds, but it is extremely important if square sections are to remain on the workpiece.
2. Put a dimple in the stock with a punch awl or nail (or use a spring-loaded automatic center punch).

NOTE: For extremely hard woods, you may need to cut kerfs into the ends of the stock using a band saw for it to be mounted onto the spur center and the live center.

3. Drive the spur center about 0.1 inches (3 mm) into the workpiece using a wood mallet or dead blow hammer (Fig. 18). Be careful not to split the workpiece. Do not use a steel face hammer and NEVER drive the workpiece onto the spur center while it is mounted on the spindle of the lathe.

4. Clean the tapered end of the spur center and the inside of the headstock spindle. Insert the tapered end of the spur center (with the attached workpiece) into the headstock spindle.

5. Support the workpiece while loosening the tailstock locking lever and bringing the tailstock into position. Tighten the tailstock locking lever to lock the tailstock to the bed.

6. Advance the tailstock quill with the hand wheel in order to seat the live center into the workpiece. Use enough pressure to secure the workpiece between the centers so that it won't fly off, but do not use excessive pressure. Excessive pressure runs the risk of overheating the center bearings and damaging both the workpiece and the lathe. Tighten the quill locking handle.

7. Adjust the position of the tool rest to be parallel to the workpiece. The tool rest height should be just below the centerline and approximately 0.1 to 0.2 inches (3 to 6 mm) from the corners of the workpiece to be turned. Secure the tool rest by tightening the tool rest locking handle and locking lever (Fig. 19).

8. Before switching the lathe ON, rotate the workpiece by hand to check for proper seating and clearance.

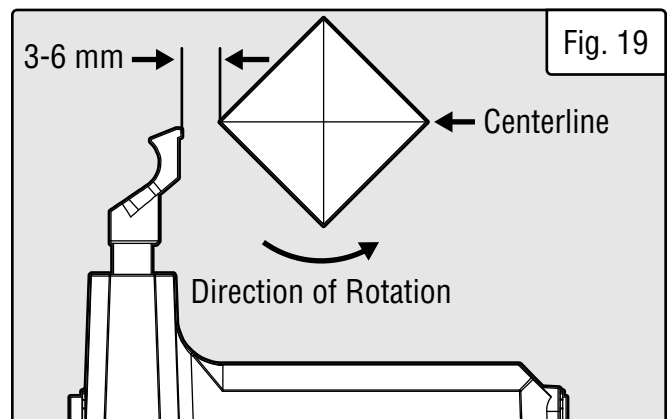
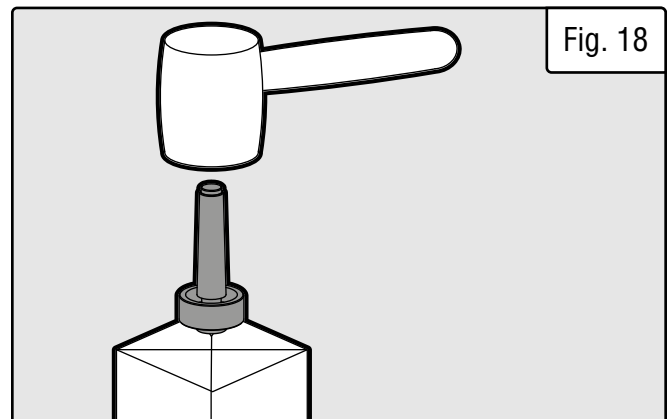

OPERATION

NOTE: The following operation instructions serves as a beginning point for some common lathe operations. Practice on scrap material to become familiarized with the operation process and make the necessary adjustments before working on your workpiece.

SPINDLE TURNING - ROUGHING OUT CUT

Roughing out is the first step of the lathe operation, which uses the large roughing gouge tool to smooth out sharp corners to make the workpiece cylindrical. When roughing out a workpiece, run the lathe at low speed and always cut downhill, from the large diameter side of the workpiece to the small diameter side.

1. Make sure the lathe turned off and disconnected. The first cut will start about 2 inches from the tailstock end of the workpiece. Adjust the tool rest to the suitable position and set the lathe to a slow speed.
2. Plug in and turn on the lathe. Wait for the motor to reach full speed. Place the roughing gouge on the tool rest about 2 inches from the tailstock end of the workpiece. Slowly and gently raise the tool handle until the cutting edge comes into contact with the workpiece.

NOTE: Make sure that the tool is being held well on the work, with the bevel or grind tangent to the revolving surface of the workpiece. This position will generate a clean shearing cut. Do not push the tool straight into the work.

3. To make the first pass, rolling the flute of the tool (the hollowed-out portion) towards the end of the tailstock.
4. Make the second pass, starting at about 2 or 3 inches to the left of the first cut. Again, advance the tool towards the tailstock, and merge with the previous cut.
5. As your cuts get close to the headstock live center end of the workpiece, roll the gouge in the opposite direction to carry the final cut off the live center end of the workpiece.

NOTE: Always work towards the end of the workpiece; NEVER start a cut at the end.

6. Make long sweeping cuts in a continuous motion to turn the workpiece to a cylinder. Keep as much of the bevel of the tool in contact with the workpiece as possible to ensure control and avoid catches. The roughing cut is continued until the work approaches about 1/8 inch to the required cylinder diameter.
7. Once the workpiece is roughed down to a cylinder, smooth it with a large skew chisel tool. The turning speed can be increased. Keep the skew handle perpendicular to the spindle and use only the center third of the cutting edge for a long smoothing cut (touching one of the points of the skew to the spinning workpiece may cause a catch and ruin the workpiece).
8. See pages 18 and 19 for adding details and finishing the workpiece.

NOTE: Remember to constantly move the tool rest inward towards the workpiece to keep a safe distance between the tool and your workpiece.

OPERATION

SPINDLE TURNING - CREATING BEADS

Making a parting cut for the desired depth and location of your bead.

1. Place the parting tool on the tool rest and move the tool forward to make the full bevel of the tool come into contact with the workpiece. Gently raise the handle to make cuts of the appropriate depth. Repeat for the other side of the bead.
2. Using a small skew or spindle gouge, start in the center between the two cuts and cut down each side to form the bead. Roll the tool in the direction of the cut.

SPINDLE TURNING - CREATING COVES

Using a spindle gouge to create a cove.

1. With the flute of the tool at 90 degrees to the workpiece, touch the point of the tool to the workpiece and roll in towards the bottom of the cove. Stop at the bottom, as attempting to go up the opposite side may cause the tool to catch.
2. Move the tool over the desired width of the cove. With the flute facing the opposite direction, repeat the step for the other side of the cove. Stop at the bottom of the cut.

SPINDLE TURNING - CREATING V-GROOVES

Using the point of the skew to create a V-groove in the workpiece.

1. Lightly mark the center of the V with the top of the skew. Move the point of the skew to the right half of the desired width of your cut.
2. With the bevel parallel to the right side of the cut, raise the handle and push the tool in to the desired depth. Repeat from the left side.

NOTE: The two cuts should meet at the bottom and leave a clean V-groove. Additional cuts may be taken to add to either the depth or the width of the cut.

SPINDLE TURNING - PARTING OFF

Adjust the lathe to a slower speed for parting through a workpiece.

1. Place a parting tool on the tool rest and raise the handle until it starts to cut. Continue cutting towards the center of the workpiece.
2. Loosely hold on to the piece in one hand as it separates from the waste wood.

OPERATION

SPINDLE TURNING - SANDING THE WORKPIECE

Adjust the lathe to a slower speed for sanding and finishing. High speed can build friction while sanding and cause burns in some woods. The cleaner the cuts, the less sanding will be required. So try to make the cuts as refined as you can before moving to the sanding process.

1. Use sandpaper finer than 120 grit, as coarse sandpaper may scratch the workpiece. Fold the sandpaper into a pad will allow easier and safer sanding. Do not wrap the sandpaper around your fingers or the workpiece.
2. Apply light pressure to the workpiece during sanding. Use power-sanding techniques to avoid concentric sanding marks around your finished piece.
3. Progress through finer grits of sandpaper until the desired surface is achieved. Finish sanding with 220 grit sandpaper.

SPINDLE TURNING - FINISHING THE WORKPIECE

1. Turn off the lathe. The workpiece can be left on the lathe when applying finish.
2. Remove the sanding dust with tack cloth or compressed air.
3. Apply the finish using a brush or paper towel. Let the finish stand for several minutes and remove any excess finish before restarting the lathe.
4. Start the lathe at the lowest speed, as high speed may cause the fresh coat to splash. Allow the finish to dry and sand the workpiece with 320 to 400 grit sandpaper.
5. Apply a second coat of finish and buff the workpiece.

MOUNT THE WORKPIECE ONTO THE FACE PLATE

When turning bowls or plates with a large diameter, mounting it to the face plate to gives the maximum amount of support. While face plates are the most reliable method for holding a larger block of wood for turning, a lathe chucks can also be used. A chuck is handy when working on more than one piece at a time, allowing your to open the chuck and change workpieces instead of having to remove the mounting screws.

1. Select a stock that is at least 0.2 inches (5 mm) larger than each dimension of the finished workpiece.
2. Remove any bark from the top of the wood stock (that will be later attached onto a face plate or in a chuck).
3. True one of the surfaces of the workpiece for mounting against the face plate. Using the face plate as a template, mark the location of the mounting holes on the workpiece and drill pilot holes of the appropriate size.

OPERATION

TO SHAPE THE INSIDE OF A BOWL OR PLATE

Turn off the lathe and move the tailstock out of the way. Mount the workpiece onto the face plate and install the face plate onto the headstock (see "Install The Face Plate" on page 12). Adjust the tool rest in front of the workpiece to be just below the centerline and at the right angle to the lathe's turning axis. Rotate the workpiece by hand to check for proper seating and clearance.

Begin shaping by lightly shearing across the top of the bowl from rim to center. Place a bowl gouge tool on the tool rest at the center of the workpiece with the flute facing the top of the bowl. The tool handle should be level and pointed toward the four o'clock position.

Control the cutting edge of the gouge with the left hand, while swinging the tool handle around towards your body with the right hand. The flute should start out facing the top of the workpiece, rotating it upwards as it moves deeper into the bowl to maintain a clean and even curve. As the tool goes deeper into the bowl, progressively work outwards towards the rim of the bowl. It may be necessary to turn the tool rest into the piece as you get deeper into the bowl.

NOTE: Try to make one light continuous movement from the rim to the bottom of the bowl to ensure a clean, sweeping curve through the piece. Should there be a few small ridges left, a light cut with a large domed scraper can even out the surface.

Develop the preferred wall thickness at the rim and maintain it as you work deeper into the bowl (once the piece is thin toward the bottom, you cannot make it thinner at the rim). When the interior is finished, move the tool rest back to the exterior to re-define the bottom of the bowl. Work the tight area around the face plate or the chuck with a bowl gouge. Begin the separation with a parting tool, but do not cut all the way through.

TROUBLESHOOTING GUIDE

The variable speed display will show an error code if the lathe has been used incorrectly. Refer to the chart below to troubleshoot the problem.

ERROR CODE	PROBLEM	SOLUTION
F1	Low voltage protection has activated.	Check supply voltage and restart lathe.
F2	High voltage protection has activated.	Check supply voltage and restart lathe.
F3	Operator error - direction changed while the lathe was ON.	Turn lathe OFF and wait for the display to show 00, then restart the lathe. ONLY change directions when the lathe is OFF.

TROUBLESHOOTING GUIDE

⚠ WARNING! Stop using the tool immediately if any of the following problems occur. Repairs and replacements should only be performed by an authorized technician. For any questions, please contact our customer service at (800) 232-1195, M-F 8-5 CST or email us at techsupport@wenproducts.com.

PROBLEM	POSSIBLE CAUSE	SOLUTION
Motor will not start.	1. Power cord damaged or not properly plugged in.	1. Check the power cord, extension cord, power plug and the power outlet. Do not use the tool if any cord is damaged.
	2. Defective power switch.	2. Stop using the tool and call 1-800-232-1195 for customer service.
	3. Defective motor or other internal damage.	3. Stop using the tool and call 1-800-232-1195 for customer service.
	4. Motor carbon brushes are worn	4. Have the carbon brushes checked and replaced by an experienced technician.
Motor or spindle stalls.	1. Excessive cut	1. Reduce the depth of the cut
	2. Worn, damaged, or improperly adjusted drive belt	2. Adjust or replace the drive belt (Part No. 34034-205) .
	3. Worn bearings.	3. Stop using the tool and call 1-800-232-1195 for customer service.
Excessive vibration.	1. Workpiece is warped, out of round, has major flaw, or was improperly prepared for turning.	1. Correct the problem by planing or sawing workpiece, or discard it entirely and restart.
	2. Worn bearings.	2. Stop using the tool and call 1-800-232-1195 for customer service.
	3. Worn drive belt.	3. Replace the drive belt (Part No. 34034-205) .
	4. Lathe is on an uneven surface.	4. Mount the lathe on a stable, flat surface.
Tools grab or dig in.	1. Dull tools.	1. Use sharp tools.
	2. Tool rest position too low.	2. Reposition the tool rest height.
	3. Tool rest position too far from work piece.	3. Reposition the tool rest closer to the workpiece.
	4. Improper tool being used.	4. Use correct tool for operation.
Tailstock or tool rest base moves when locked and pressure is applied.	1. Lock nut needs adjusting.	1. Adjust lock nut (Part No. 34034-052) . Make small adjustments (1/8 turn) at a time until the tailstock or tool rest base locks down securely. Call 1-800-232-1195 for customer service.
	2. Lathe bed and tailstock or tool rest base mating surfaces are greasy or oily.	2. Remove the tailstock or tool rest base and clean the surfaces with a cleaner. Apply a light coat of oil to the lathe bed surface.
Error code shown.	1. Lathe is being used incorrectly.	1. Consult chart on page 20.

NOTE: Repairs and replacements should only be performed by an authorized technician. Parts and accessories that wear down over the course of normal use are not covered by the two-year warranty.

MAINTENANCE

⚠ WARNING! To avoid accidents, turn OFF and unplug the tool from the electrical outlet before cleaning, adjusting, or performing any maintenance work.

⚠ WARNING! Any attempt to repair or replace electrical parts on this tool may be hazardous. Servicing of the tool must be performed by a qualified technician. When servicing, use only identical WEN replacement parts. Use of other parts may be hazardous or induce product failure.

ROUTINE INSPECTION

Before each use, inspect the general condition of the tool. If any of these following conditions exist, do not use until parts are replaced or the lathe is properly repaired.

Check for:

- Loose hardware,
- Misalignment or binding of moving parts,
- Damaged cord/electrical wiring,
- Cracked or broken parts, and
- Any other condition that may affect its safe operation.

CLEANING & STORAGE

1. Keep the ventilation openings free from dust and debris to prevent the motor from overheating.

2. Wipe the tool surfaces clean with a clean cloth. Make sure water does not get into the tool.

CAUTION! Most plastics are susceptible to damage from various types of commercial solvents. Do not use any solvents or cleaning products that could damage the plastic parts. Some of these include but are not limited to: gasoline, carbon tetrachloride, chlorinated cleaning solvents, and household detergents that contain ammonia.

3. Store the tool in a clean and dry place away from the reach of children. Store in temperatures between 41° to 86°F.

4. Cover the Lathe in order to protect it from dust and moisture. It is preferable to store it in its original packaging with the instruction manual and all accessories.

LUBRICATION

The bearings of your Lathe are permanently sealed and require no extra lubrication.

DRIVE BELT

The drive belt should last for many years depending on usage, but it needs to be inspected regularly for cracks, cuts and general wear. If damage is found, replace the belt before operation.

RUST

The Lathe is made from steel and cast iron. All non-painted surfaces will rust if not protected. It is recommended that they are protected by applying a light coat of good-quality paste wax to the surfaces to guard against rust and corrosion.

PRODUCT DISPOSAL

Used power tools should not be disposed of together with household waste. This product contains electronic components that should be recycled. Please take this product to your local recycling facility for responsible disposal and to minimize its environmental impact.



Please recycle the packaging and electronic components where facilities exist.

EXPLODED VIEW & PARTS LIST

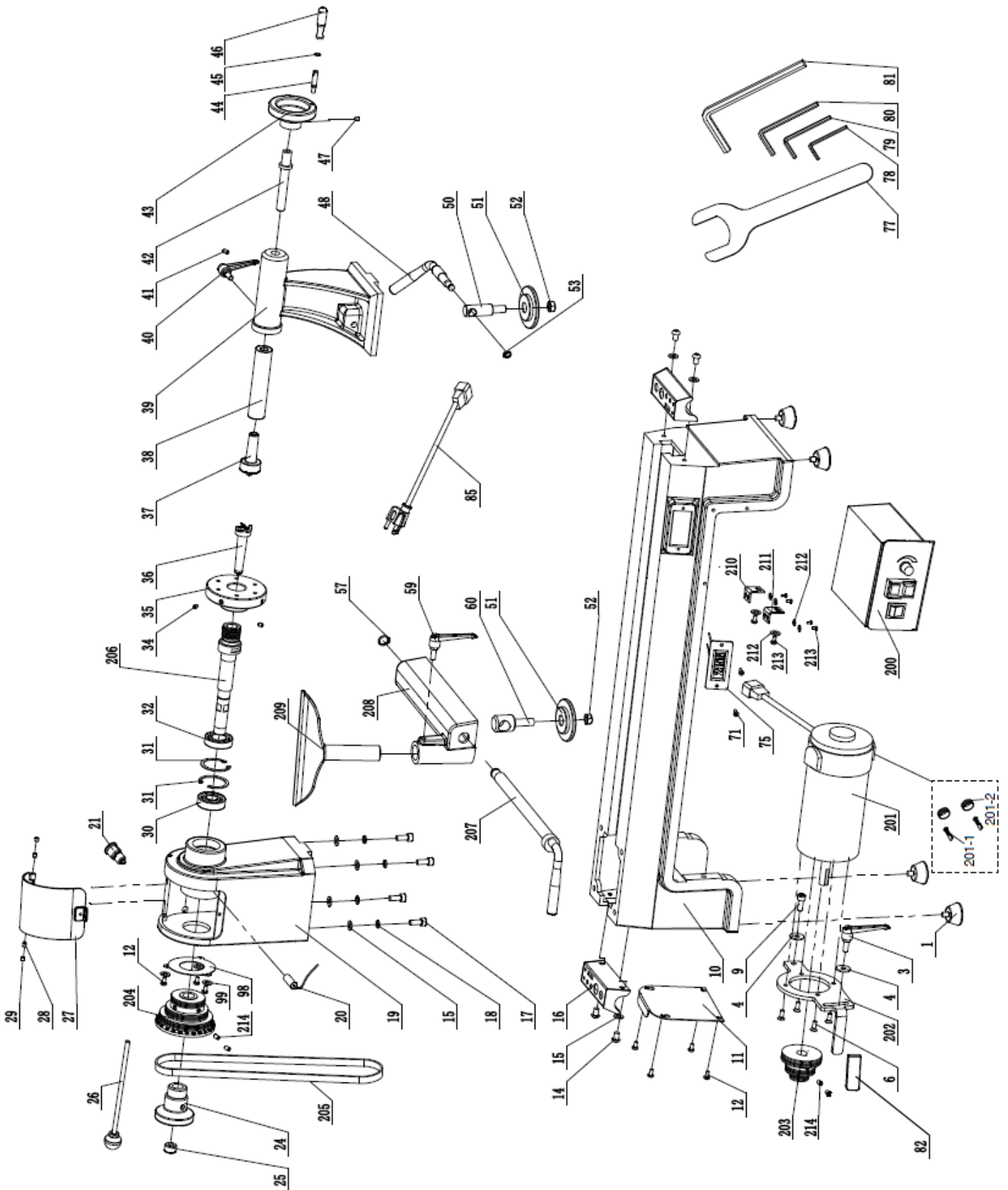

NOTE: Not all parts may be available for purchase. Parts and accessories that wear down over the course of normal use are not covered under the warranty.

EXPLODED VIEW & PARTS LIST

No.	Part No.	Description	Qty.
1	34034-001	Foot	4
3	34034-003	Belt Tension Lock Lever, M8x20	1
4	34034-004	Washer, 8mm	2
6	34034-006	Head Cap Screw, M6x16	4
9	34034-009	Cap Screw, M8x16	1
10	34034-010	Bed	1
11	34034-011	Lower Belt Door	1
12	34034-012	Phillip Head Screw, M5x10	7
14	34034-014	Head Screw, M8x12	4
15	34034-015	Washer, 8mm	8
16	34034-016	Handle With Tool Rack	2
17	34034-017	Cap Screw, M8x20	4
18	34034-018	Spring Washer, 8mm	4
19	34034-019B	Headstock Body	1
20	34034-020	Spindle Speed Sensor, M8x20	1
21	34034-021	Location Pin Assembly	1
24	34034-024	Headstock Handwheel	1
25	34034-025	Locking Nut, M20-1.5x12	1
26	34034-026	Knockout Rod Assembly	1
27	34034-027B	Upper Belt Door	1
28	34034-028	Cap Screw, M5x10	2
29	34034-029	Set Screw, M5x6	2
30	34034-030	Bearing, 6204	1
31	34034-031	Ring	2
32	34034-032	Bearing, 6005	1
34	34034-034	Cap Screw, M6x8	2
35	34034-035	Face Plate	1
36	34034-036	Spur Center	1
37	34034-037	Live Center	1
38	34034-038B	Quill	1
39	34034-039B	Tailstock	1
40	34034-040	Quill Lock Lever	1
41	34034-041	Pin	1
42	34034-042B	Leadscrew	1
43	34034-043	Tailstock Wheel	1
44	34034-044	Handwheel Axle	1
45	34034-045	Ring	1
46	34034-046	Handwheel Handle	1

No.	Part No.	Description	Qty.
47	34034-047	Set Screw, M8x10	1
48	34034-048	Tailstock Lock Lever	1
50	34034-050	Tailstock Clamp Bolt	1
51	34035-051	Tailstock Clamp Plate	2
52	34034-052	Lock Nut, M12	2
53	34034-053	C-Ring	1
57	34034-057	C-Ring	2
59	34034-059	Lock Lever	1
60	34034-060	Tool Rest Clamp Bolt	1
71	34034-071	Phillip Head Screw, M4x8	2
75	34034-075	RPM Digital Readout	1
77	34034-077	Wrench	1
78	34034-078	Hex Wrench, 3mm	1
79	34034-079	Hex Wrench, 4mm	1
80	34034-080	Hex Wrench, 5mm	1
81	34034-081	Hex Wrench, 12mm	1
82	34034-082	Handle Sleeve	1
85	34034-085	Power Plug	1
98	34034-098	Headstock Cover	1
99	34034-099	Washer, 5mm	3
200	34034-200	Electrical Box Assembly	1
201	34034-201	Motor	1
201-1	34034-215	Carbon Brush	2
201-2	34034-216	Carbon Brush Cap	2
202	34034-202	Motor Plate	1
203	34034-203	Motor Pulley	1
204	34034-204	Spindle Pulley	1
205	34034-205	Belt, Micro-V 310J	1
206	34034-206	Spindle	1
207	34034-207	Tool Rest Base Lock Lever	1
208	34034-208	Tool Rest Base (Banjo)	1
209	34034-209	Tool Rest	1
210	34034-210	Electrical Box Bracket 2	1
211	34034-211	Electrical Box Bracket 1	1
212	34034-212	Washer, 4mm	6
213	34034-213	Screw, M5x10	6
214	34034-214	Screw, M8x10	4

WARRANTY STATEMENT

WEN Products is committed to building tools that are dependable for years. Our warranties are consistent with this commitment and our dedication to quality.

LIMITED WARRANTY OF WEN PRODUCTS FOR HOME USE

GREAT LAKES TECHNOLOGIES, LLC (“Seller”) warrants to the original purchaser only, that all WEN consumer power tools will be free from defects in material or workmanship during personal use for a period of two (2) years from date of purchase or 500 hours of use; whichever comes first. Ninety days for all WEN products if the tool is used for professional or commercial use. Purchaser has 30 days from the date of purchase to report missing or damaged parts.

SELLER’S SOLE OBLIGATION AND YOUR EXCLUSIVE REMEDY under this Limited Warranty and, to the extent permitted by law, any warranty or condition implied by law, shall be the replacement of parts, without charge, which are defective in material or workmanship and which have not been subjected to misuse, alteration, careless handling, misrepair, abuse, neglect, normal wear and tear, improper maintenance, or other conditions adversely affecting the Product or the component of the Product, whether by accident or intentionally, by persons other than Seller. To make a claim under this Limited Warranty, you must make sure to keep a copy of your proof of purchase that clearly defines the Date of Purchase (month and year) and the Place of Purchase. Place of Purchase must be a direct vendor of Great Lakes Technologies, LLC. Purchasing through third party vendors, including but not limited to garage sales, pawn shops, resale shops, or any other secondhand merchant, voids the warranty included with this product. Contact tech-support@wenproducts.com or 1-800-232-1195 with the following information to make arrangements: your shipping address, phone number, serial number, required part numbers, and proof of purchase. Damaged or defective parts and products may need to be sent to WEN before the replacements can be shipped out.

Upon the confirmation of a WEN representative, your product may qualify for repairs and service work. When returning a product for warranty service, the shipping charges must be prepaid by the purchaser. The product must be shipped in its original container (or an equivalent), properly packed to withstand the hazards of shipment. The product must be fully insured with a copy of the proof of purchase enclosed. There must also be a description of the problem in order to help our repairs department diagnose and fix the issue. Repairs will be made and the product will be returned and shipped back to the purchaser at no charge for addresses within the contiguous United States.

THIS LIMITED WARRANTY DOES NOT APPLY TO ITEMS THAT WEAR OUT FROM REGULAR USAGE OVER TIME, INCLUDING BELTS, BRUSHES, BLADES, BATTERIES, ETC. ANY IMPLIED WARRANTIES SHALL BE LIMITED IN DURATION TO TWO (2) YEARS FROM DATE OF PURCHASE. SOME STATES IN THE U.S. AND SOME CANADIAN PROVINCES DO NOT ALLOW LIMITATIONS ON HOW LONG AN IMPLIED WARRANTY LASTS, SO THE ABOVE LIMITATION MAY NOT APPLY TO YOU.

IN NO EVENT SHALL SELLER BE LIABLE FOR ANY INCIDENTAL OR CONSEQUENTIAL DAMAGES (INCLUDING BUT NOT LIMITED TO LIABILITY FOR LOSS OF PROFITS) ARISING FROM THE SALE OR USE OF THIS PRODUCT. SOME STATES IN THE U.S. AND SOME CANADIAN PROVINCES DO NOT ALLOW THE EXCLUSION OR LIMITATION OF INCIDENTAL OR CONSEQUENTIAL DAMAGES, SO THE ABOVE LIMITATION OR EXCLUSION MAY NOT APPLY TO YOU.

THIS LIMITED WARRANTY GIVES YOU SPECIFIC LEGAL RIGHTS, AND YOU MAY ALSO HAVE OTHER RIGHTS WHICH VARY FROM STATE TO STATE IN THE U.S., PROVINCE TO PROVINCE IN CANADA AND FROM COUNTRY TO COUNTRY.

THIS LIMITED WARRANTY APPLIES ONLY TO ITEMS SOLD WITHIN THE UNITED STATES OF AMERICA, CANADA AND THE COMMONWEALTH OF PUERTO RICO. FOR WARRANTY COVERAGE WITHIN OTHER COUNTRIES, CONTACT THE WEN CUSTOMER SUPPORT LINE. FOR WARRANTY PARTS OR PRODUCTS REPAIRED UNDER WARRANTY SHIPPING TO ADDRESSES OUTSIDE OF THE CONTIGUOUS UNITED STATES, ADDITIONAL SHIPPING CHARGES MAY APPLY.

**THANKS FOR
REMEMBERING**

