

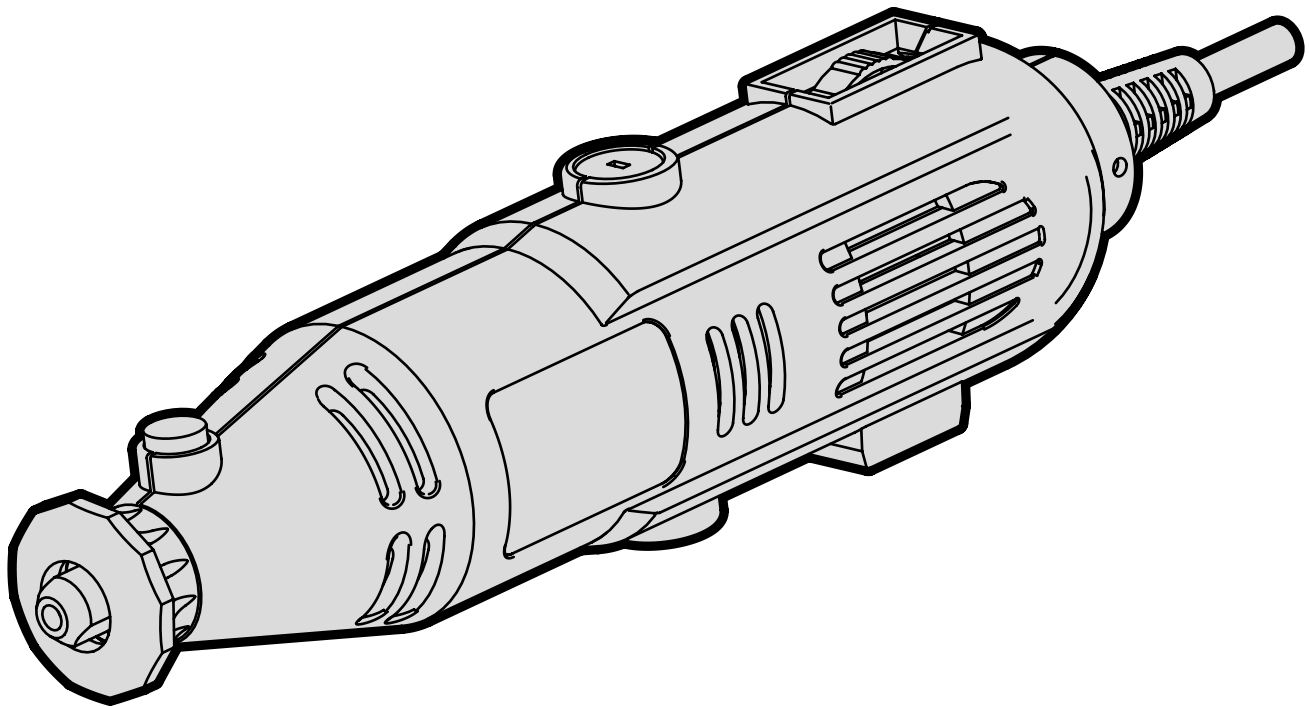

**MODEL 2305**

# **VARIABLE SPEED ROTARY TOOL**

**WITH CASE AND FLEX SHAFT**



## ***NEED HELP? CONTACT US!***

Have product questions? Need technical support? Please feel free to contact us:



**1-800-232-1195 (M-F 8AM-5PM CST)**



**TECHSUPPORT@WENPRODUCTS.COM**

**IMPORTANT:** Your new tool has been engineered and manufactured to WEN's highest standards for dependability, ease of operation, and operator safety. When properly cared for, this product will supply you years of rugged, trouble-free performance. Pay close attention to the rules for safe operation, warnings, and cautions. If you use your tool properly and for its intended purpose, you will enjoy years of safe, reliable service.

For replacement parts and the most up-to-date instruction manuals, visit ***WENPRODUCTS.COM***

# CONTENTS

<b>WELCOME</b>	<b>3</b>
Introduction .....	3
Specifications.....	3
<b>SAFETY</b>	<b>4</b>
General Safety Rules .....	4
Rotary Tool Safety Warnings.....	6
Electrical Information .....	7
<b>BEFORE OPERATING</b>	<b>8</b>
Know Your Rotary Tool .....	8
Assembly & Adjustment.....	10
<b>OPERATION &amp; MAINTENANCE</b>	<b>12</b>
Operation .....	12
Maintenance.....	13
Warranty Statement .....	14

To purchase accessories for your tool, visit ***WENPRODUCTS.COM***

**150-Piece Rotary Tool Kit** (Model 230151A)

**282-Piece Rotary Tool Kit** (Model 230282A)

**320-Piece Rotary Tool Kit** (Model 230321A)

**327-Piece Rotary Tool Kit** (Model 230327A)

**Keyless Rotary Tool Chuck** (Model 2305-KC)

## INTRODUCTION

Thanks for purchasing the WEN Rotary Tool. We know you are excited to put your tool to work, but first, please take a moment to read through the manual. Safe operation of this tool requires that you read and understand this operator's manual and all the labels affixed to the tool. This manual provides information regarding potential safety concerns, as well as helpful assembly and operating instructions for your tool.

 Indicates danger, warning, or caution. The safety symbols and the explanations with them deserve your careful attention and understanding. Always follow the safety precautions to reduce the risk of fire, electric shock or personal injury. However, please note that these instructions and warnings are not substitutes for proper accident prevention measures.

**NOTE:** The following safety information is not meant to cover all possible conditions and situations that may occur. WEN reserves the right to change this product and specifications at any time without prior notice.

At WEN, we are continuously improving our products. If you find that your tool does not exactly match this manual, please visit [wenproducts.com](http://wenproducts.com) for the most up-to-date manual or contact our customer service at **1-800-232-1195**.

**Keep this manual available to all users during the entire life of the tool and review it frequently to maximize safety for both yourself and others.**

## SPECIFICATIONS

Model Number	2305
Motor	120V, 50 Hz, 1.0A, AC Only
No Load Speed	8,000 - 30,000 RPM
Collet Size	1/8" (3.2 mm) and 3/32" (2.3 mm)
Weight	1.1 lbs

## INCLUDED ACCESSORIES

Rotary Tool .....	1	Cut-Off Wheels.....	3
Flex Shaft .....	1	Sander Bands.....	4
Storage Case.....	1	Sanding drum .....	1
Felt Polishing Wheels.....	2	Mandrels.....	2
High Speed Cutters .....	2	Drill Bits (1/8" and 3/32") .....	2
Grinding Stones .....	10	Collets (1/8" and 3/32") .....	2
Sanding Discs .....	51	Collet Nut Wrench.....	1
Dressing Stone .....	1		

# GENERAL SAFETY RULES

**⚠ WARNING!** Read all safety warnings and all instructions. Failure to follow the warnings and instructions may result in electric shock, fire and/or serious injury.

Safety is a combination of common sense, staying alert and knowing how your item works. The term “power tool” in the warnings refers to your mains-operated (corded) power tool or battery-operated (cordless) power tool.

## SAVE THESE SAFETY INSTRUCTIONS.

### WORK AREA SAFETY

- 1. Keep work area clean and well lit.** Cluttered or dark areas invite accidents.
- 2. Do not operate power tools in explosive atmospheres, such as in the presence of flammable liquids, gases or dust.** Power tools create sparks which may ignite the dust or fumes.
- 3. Keep children and bystanders away while operating a power tool.** Distractions can cause you to lose control.

### ELECTRICAL SAFETY

- 1. Power tool plugs must match the outlet. Never modify the plug in any way. Do not use any adapter plugs with earthed (grounded) power tools.** Unmodified plugs and matching outlets will reduce risk of electric shock.
- 2. Avoid body contact with earthed or grounded surfaces such as pipes, radiators, ranges and refrigerators.** There is an increased risk of electric shock if your body is earthed or grounded.
- 3. Do not expose power tools to rain or wet conditions.** Water entering a power tool will increase the risk of electric shock.
- 4. Do not abuse the cord. Never use the cord for carrying, pulling or unplugging the power tool. Keep cord away from heat, oil, sharp edges or moving parts.** Damaged or entangled cords increase the risk of electric shock.
- 5. When operating a power tool outdoors, use an extension cord suitable for outdoor use.** Use of a cord suitable for outdoor use reduces the risk of electric shock.

**6. If operating a power tool in a damp location is unavoidable, use a ground fault circuit interrupter (GFCI) protected supply.** Use of a GFCI reduces the risk of electric shock.

### PERSONAL SAFETY

- 1. Stay alert, watch what you are doing and use common sense when operating a power tool. Do not use a power tool while you are tired or under the influence of drugs, alcohol or medication.** A moment of inattention while operating power tools may result in serious personal injury.
- 2. Use personal protective equipment. Always wear eye protection.** Protective equipment such as a respiratory mask, non-skid safety shoes and hearing protection used for appropriate conditions will reduce the risk of personal injury.
- 3. Prevent unintentional starting. Ensure the switch is in the off-position before connecting to power source and/or battery pack, picking up or carrying the tool.** Carrying power tools with your finger on the switch or energizing power tools that have the switch on invites accidents.
- 4. Remove any adjusting key or wrench before turning the power tool on.** A wrench or a key left attached to a rotating part of the power tool may result in personal injury.
- 5. Do not overreach. Keep proper footing and balance at all times.** This enables better control of the power tool in unexpected situations.
- 6. Dress properly. Do not wear loose clothing or jewelry. Keep your hair and clothing away from moving parts.** Loose clothes, jewelry or long hair can be caught in moving parts.

# GENERAL SAFETY RULES

**⚠ WARNING!** Read all safety warnings and all instructions. Failure to follow the warnings and instructions may result in electric shock, fire and/or serious injury.

Safety is a combination of common sense, staying alert and knowing how your item works. The term “power tool” in the warnings refers to your mains-operated (corded) power tool or battery-operated (cordless) power tool.

## SAVE THESE SAFETY INSTRUCTIONS.

**7. If devices are provided for the connection of dust extraction and collection facilities, ensure these are connected and properly used.** Use of dust collection can reduce dust-related hazards.

### POWER TOOL USE AND CARE

**1. Do not force the power tool. Use the correct power tool for your application.** The correct power tool will do the job better and safer at the rate for which it was designed.

**2. Do not use the power tool if the switch does not turn it on and off.** Any power tool that cannot be controlled with the switch is dangerous and must be repaired.

**3. Disconnect the plug from the power source and/or the battery pack from the power tool before making any adjustments, changing accessories, or storing power tools.** Such preventive safety measures reduce the risk of starting the power tool accidentally.

**4. Store idle power tools out of the reach of children and do not allow persons unfamiliar with the power tool or these instructions to operate the power tool.** Power tools are dangerous in the hands of untrained users.

**5. Maintain power tools. Check for misalignment or binding of moving parts, breakage of parts and any other condition that may affect the power tool's operation. If damaged, have the power tool repaired before use.** Many accidents are caused by poorly maintained power tools.

**6. Keep cutting tools sharp and clean.** Properly maintained cutting tools with sharp cutting edges are less likely to bind and are easier to control.

**7. Use the power tool, accessories and tool bits, etc. in accordance with these instructions, taking into account the working conditions and the work to be performed.** Use of the power tool for operations different from those intended could result in a hazardous situation.

**8. Use clamps to secure your workpiece to a stable surface.** Holding a workpiece by hand or using your body to support it may lead to loss of control.

**9. KEEP GUARDS IN PLACE** and in working order.

### SERVICE

**1. Have your power tool serviced by a qualified repair person using only identical replacement parts.** This will ensure that the safety of the power tool is maintained.

### CALIFORNIA PROPOSITION 65 WARNING

Some dust created by power sanding, sawing, grinding, drilling, and other construction activities may contain chemicals, including lead, known to the State of California to cause cancer, birth defects, or other reproductive harm. Wash hands after handling. Some examples of these chemicals are:

- Lead from lead-based paints.
- Crystalline silica from bricks, cement, and other masonry products.
- Arsenic and chromium from chemically treated lumber.

Your risk from these exposures varies depending on how often you do this type of work. To reduce your exposure to these chemicals, work in a well-ventilated area with approved safety equipment such as dust masks specially designed to filter out microscopic particles.

# ROTARY TOOL SAFETY WARNINGS

 **WARNING!** Do not operate the power tool until you have read and understood the following instructions and the warning labels.

## ROTARY TOOL SAFETY

**1. Work environment.** Do not operate the tool in wet or damp conditions; doing so significantly increases the risk of electrical shock. Do not operate the tool in the presence of flammable liquids or gases.

**2. Tool inspection.** Before operation, check the tool for any damage or missing parts. Do not use the tool if any part is missing or damaged. Do not use the tool if the power switch is faulty, the plug or cable is damaged, or the tool produces sparks, smoke, or unpleasant odors (you may smell brushes burning for a few minutes as the tool breaks in during the first use, that is okay). Make sure all adjustments are correct and all connections are tight.

**3. Accessories inspection.** The accessory must have a rated speed higher than or equal to 30,000 RPM (the maximum tool operating speed of your rotary tool), otherwise there is a risk of injury. The spindle size of the accessory must properly fit the tool's collet in order to be mounted securely. Before operation, inspect the accessories for any chips, cracks or excess wear. Do not use damaged accessories.

**4. workpiece inspection.** Check the workpiece for any cracks, bumps, nails or obstructions before commencing operation. Do not cut any workpiece that exceeds the rotary tool or the rotary tool bit's operation capacity. Check the position of all electrical wiring and plumbing equipment when drilling into walls, floors or ceilings.

**5. Securing the workpiece.** Use clamps to secure the workpiece whenever possible to prevent wobble, damage to the workpiece, and personal injury.

**6. Personal Safety.** Always use safety goggles, a dust mask and hearing protection when using the rotary tool. Always maintain a firm grip on the rotary tool by the insulated gripping surfaces only.

**7. Setting the speed.** Set suitable speed for your operation, workpiece and accessory. Use slow speeds for some plastics and precious metals to prevent damaging the material. Use slow speeds (15,000 RPM or less) for all brushing applications using wire wheels and polishing operations using felt polishing accessories. Use higher speeds for drilling, carving, cutting, routing, shaping, cutting dados or rabbets in wood, metal, and glass.

**8. Using the flex shaft.** Never cross the flex shaft over itself during operation. Do not bend the flex shaft near its connection to the rotary tool. Do not operate the flex shaft with a sharp bend. The recommended minimum radius for the flex shaft is 5 inches. Bending the shaft farther than this can generate excessive heat and damage the flex shaft. Make sure to lubricate the flex shaft inner core every couple of hours of operation.

**9. Turning on the Tool.** Before turning on the rotary tool, ensure that it is completely clear of the workpiece. Let the tool reach full speed before making contact with the workpiece.

**10. During Operation.** Do not apply excessive pressure to the tool or attempt to make an excessive depth of cut. Overstressing the tool may cause kickback and damage the tool and accessories. Use special care when working corners, sharp edges etc. Avoid bouncing and snagging the accessory. Never touch any moving parts of the tool by hand. Never press in the spindle lock button when the rotary tool is running.

**11. Turning off the Tool.** Clear the tool from the workpiece before switching off the tool. Wait for the rotary bit to come to a complete stop before setting the tool down.

**12. Making adjustments.** Always turn off the machine and disconnect from the power source before making adjustments or changing attachments. Do not remove the attachment from the tool until it has completely stopped rotating. Do not touch the attachment immediately after operation, as it may be very hot. Allow time for the attachment to cool and calm down before removing it.

## ELECTRICAL INFORMATION

### DOUBLE-INSULATED TOOLS

The tool's electrical system is double insulated where two systems of insulation are provided. This eliminates the need for the usual three-wire grounded power cord. Double insulated tools do not need to be grounded, nor should a means for grounding be added to the product. All exposed metal parts are isolated from the internal metal motor components with protecting insulation.

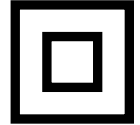

**IMPORTANT:** Servicing a double-insulated product requires extreme care and knowledge of the system, and should be done only by qualified service personnel using identical replacement parts. Always use original factory replacement parts when servicing.

1. **POLARIZED PLUGS.** To reduce the risk of electric shock, this equipment has a polarized plug (one blade is wider than the other). This plug will fit in a polarized outlet only one way. If the plug does not fit fully in the outlet, reverse the plug. If it still does not fit, contact a qualified electrician to install a proper outlet. Do not modify the machine plug or the extension cord in any way.
2. **GROUND FAULT CIRCUIT INTERRUPTER PROTECTION (GFCI)** should be provided on the circuit or outlet used for this power tool to reduce the risk of electric shock.
3. **SERVICE AND REPAIR.** To avoid danger, electrical appliances must only be repaired by qualified service technician using original replacement parts.

### GUIDELINES AND RECOMMENDATIONS FOR EXTENSION CORDS

When using an extension cord, be sure to use one heavy enough to carry the current your product will draw. An undersized cord will cause a drop in line voltage resulting in loss of power and overheating. The table below shows the correct size to be used according to cord length and ampere rating. When in doubt, use a heavier cord. The smaller the gauge number, the heavier the cord.

AMPERAGE	REQUIRED GAUGE FOR EXTENSION CORDS			
	25 ft.	50 ft.	100 ft.	150 ft.
1A	18 gauge	18 gauge	16 gauge	14 gauge

1. **EXAMINE EXTENSION CORD BEFORE USE.** Make sure your extension cord is properly wired and in good condition. Always replace a damaged extension cord or have it repaired by a qualified person before using it.
2. **DO NOT ABUSE EXTENSION CORD.** Do not pull on cord to disconnect from receptacle; always disconnect by pulling on plug. Disconnect the extension cord from the receptacle before disconnecting the product from the extension cord. Protect your extension cords from sharp objects, excessive heat and damp/wet areas.
3. **USE A SEPARATE ELECTRICAL CIRCUIT FOR YOUR TOOL.** This circuit must not be less than a 12-gauge wire and should be protected with a 15A time-delayed fuse. Before connecting the motor to the power line, make sure the switch is in the OFF position and the electric current is rated the same as the current stamped on the motor nameplate. Running at a lower voltage will damage the motor.



# KNOW YOUR ROTARY TOOL

## TOOL PURPOSE

Drill, carve, cut, and shape your workpiece using your rotary tool. Refer to the following diagrams to become familiarized with all the parts and controls of your rotary tool. The components will be referred to later in the manual for assembly and operation instructions.

## ROTARY TOOL

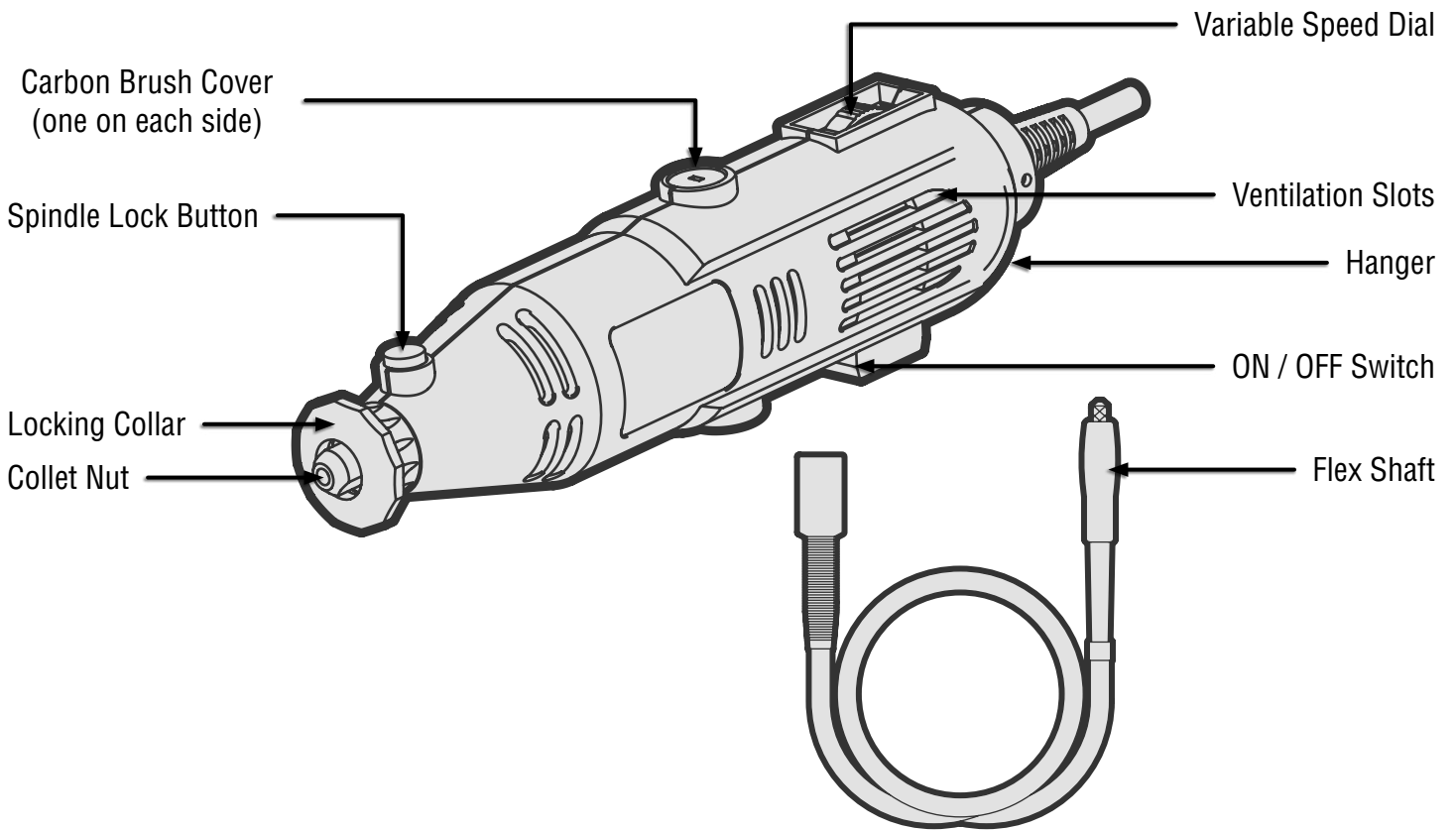



## ***KNOW YOUR ROTARY TOOL***

Refer to the chart below for explanations and recommended applications for your rotary tool accessory bits.

<b>Accessory</b>	<b>Explanation &amp; Applications</b>
1. Collet	For holding a rotary bit in place. Your tool comes with 1/8-inch and 3/32-inch collets. Use the correct size collet that matches the shank diameter of your rotary bit.
2. Wrench	The front of the wrench is for loosening the collet nut to change collets. The back of the wrench is for opening the carbon brush covers, as well as screws on the sanding drum and small screw mandrel.
3. Dressing Stone	A solid block made of hard abrasive. Breathes new life back into old or worn grinding stone bits.
4. Screw Mandrel	A mandrel with a screw head for attaching felt polishing accessories. Screw the polishing wheel attachment all the way onto the top of the mandrel (see page 10).
5. Felt Polishing Wheel	Perfect for finishing a workpiece's surface. Cleans, polishes and buffs metal, wood, and plastic. For best results, polishing accessories should be used at speeds below 15,000 RPM. Attach to the screw mandrel (see page 10).
6. Small Screw Mandrel	A mandrel with a threaded head and screw top for attaching cut-off wheels and sanding discs. See page 10 for attaching cut-off wheels and sanding discs.
7. Cut-Off Wheel	Thin disc for slicing and cutting. These discs are great for making quick cuts, and are best suited for general maintenance, repair, or industrial applications. Attach to the small screw mandrel (see page 10).
8. Sanding Disc	Disc-shaped sandpaper used for material removal and resurfacing. Attach to the small screw mandrel (see page 10).
9. Sander Band	Slides over the top of the sanding drum to remove rust, shape rubber, and smooth surfaces. Attach to the sanding drum (see page 10).
10. Sanding Drum	A mandrel with a cylinder-shaped rubber tip for attaching sanding bands.
11. Drill Bit	Cutting tool used to drill into materials such as metal, hardwood, and plastics.
12. Diamond Bit	Creates efficient cuts and easily engraves wood, plastics, and soft metals such as aluminum, copper, and brass.
13. Grinding Stone Bit	Used for various grinding and abrasive machining operations. Great for removing flash from metal castings, deburring metal after cutting, smoothing welded joints, grinding off rivets and removing rust. Can be resharpened with a dressing stone.

## ASSEMBLY & ADJUSTMENTS

**⚠ WARNING!** To avoid injury from accidental startups, always ensure that the tool is switched OFF and unplugged from the power supply before making adjustments or changing accessories.

### INSTALLING ROTARY TOOL BITS

1. Switch off and unplug the tool before attempting any adjustments.

2. Hold down the spindle lock button (Fig. 1 - 1) and rotate the collet nut (Fig. 1 - 2) until the lock engages.

3. Using the included wrench, loosen the collet nut (Fig. 1 - 2) by turning it counterclockwise and remove. Release the spindle lock button.

4. The collet is located inside the collet nut. Your rotary tool is pre-installed with a 1/8" collet and includes a 3/32" collet as an accessory. Select the suitable collet to match the shank diameter of your rotary tool bit. Insert the selected collet into the spindle and screw the collet nut back on, but do not tighten it all the way.

5. Fully insert the bit through the hole in the center of the collet nut and into the collet. Press down the spindle lock button and fully tighten the collet nut using the included wrench. Check to ensure that the rotary bit is firmly secured inside the tool.

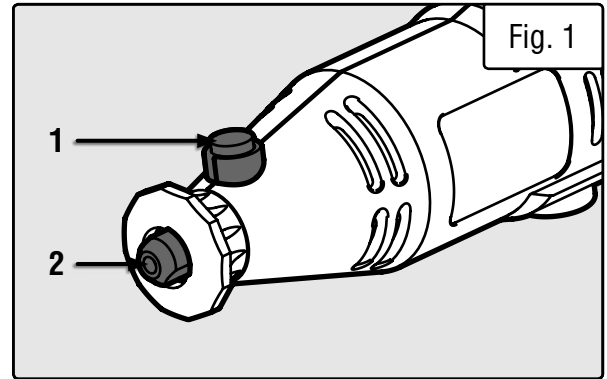

### INSTALLING SANDING DISCS AND CUTTING WHEELS

Loosen and remove the screw at the top of the small screw mandrel. Remove the top red ring from the screw and slide the cutoff wheel or sanding disc above the bottom red ring (ensure the abrasive side of the disc is facing up). Slide the top red ring above the cutoff wheel or sanding disc, so that there is one red ring on each side of the wheel or disc. Reattach the screw onto the mandrel to secure the wheel/disc in place. Your accessory is now ready to be attached to the rotary tool (follow the steps in "Installing the Rotary Bits" above).

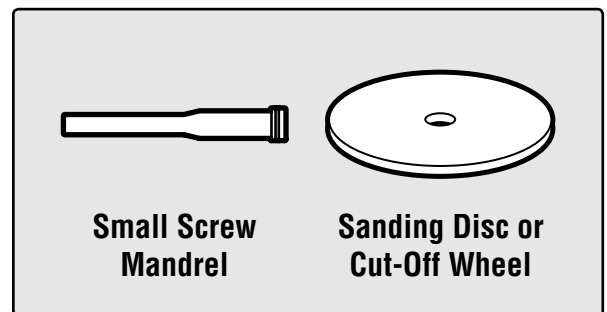

### INSTALLING SANDING BANDS

Loosen the screw on the top of the sanding drum using the end of the collet nut wrench. Slide the sanding band onto the sanding drum. Fully tighten the screw to expand the drum and hold the sanding band in place. Make sure the sanding drum is sufficiently expanded to secure the band during use. If sanding band is loose on the drum, it may fly off during operation and cause injuries.

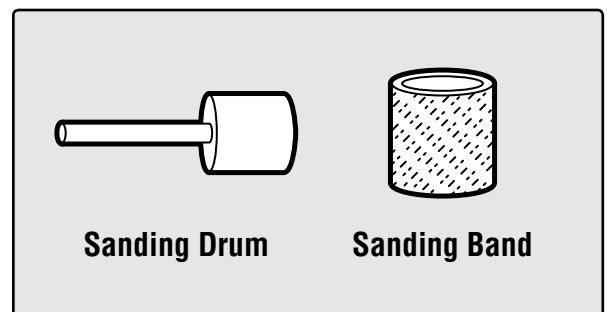

### INSTALLING FELT POLISHING ACCESSORIES

Thread the felt polishing accessory straight down onto the tip of the screw mandrel. The accessory must be threaded all the way down to touch the collar of the screw mandrel.

**IMPORTANT:** Before operation, check to make sure that all accessories are assembled correctly and securely.

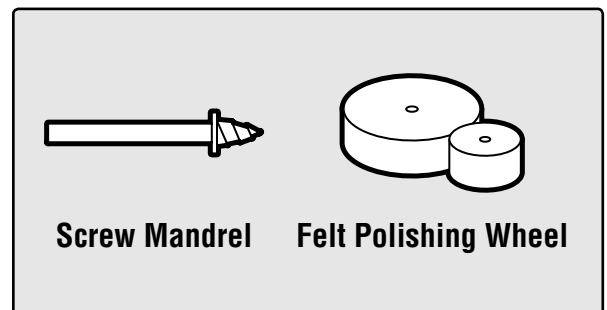

## ASSEMBLY & ADJUSTMENTS

### ATTACHING THE FLEX SHAFT

For video instructions on attaching the flex shaft, visit:  
<http://bit.ly/wenflexshaft>

1. Unscrew and remove the locking collar from the end of the rotary tool (Fig. 2).

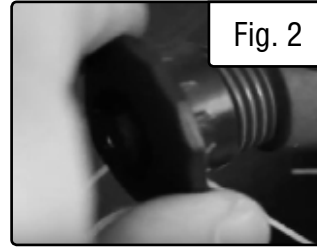

2. Take the flex shaft and slide the inner core out about 2 to 3 inches (Fig. 3). **NOTE:** it is OK if the flex shaft core falls out! Just put it back into the sheath. This is normal and does not indicate a problem.

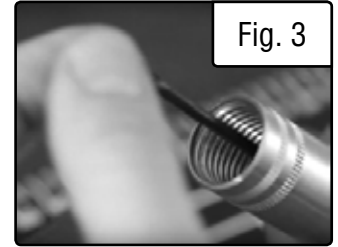

3. Loosen the collet nut on the rotary tool by pressing down on the spindle lock button and unscrewing the collet nut (Fig. 4). Use the 1/8 in. collet for attaching the flex shaft.

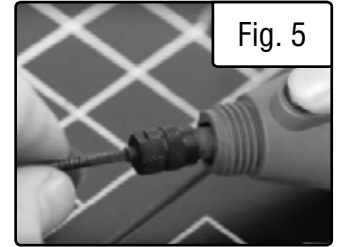
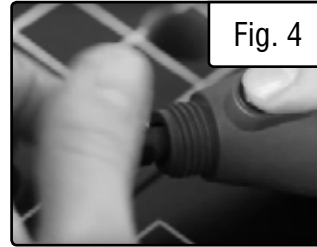

4. Insert the inner core of the flex shaft into the collet nut and collet (Fig. 5). Make sure that the metal ring is pressed tightly against the collet nut. Press down on the spindle lock button, and fully tighten the collet nut with the included wrench.

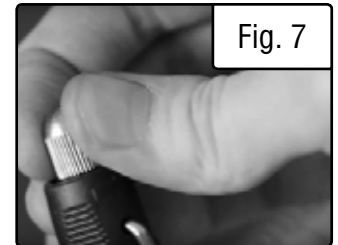
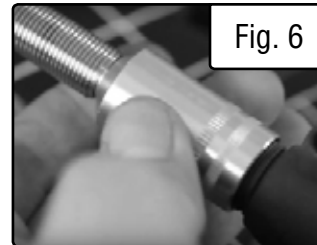

5. Now that the inner core is secured to the collet nut, slide down the flex shaft adapter and screw it in place onto the rotary tool by turning it clockwise (Fig. 6).

6. Once secured, take other end of flex shaft. Find L-shaped tool and insert it into the hole on the side of the flex shaft handle to prevent the flex shaft spindle from rotating (Fig. 7).

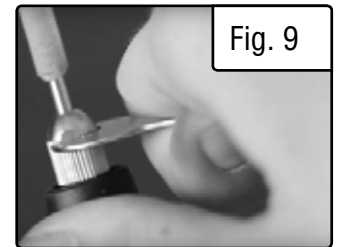
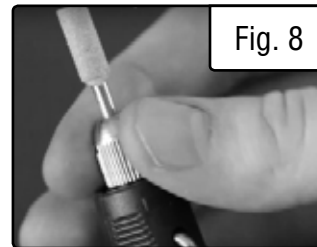

7. Unscrew the shaft collet nut and check the size of the collet against your rotary bit. Always select the correct size of collet for the operation (Fig. 8).

8. Install the collet and collet nut and fully insert the rotary bit into the center hole through the collet. Use the included wrench to fully tighten the collet nut and ensure that the bit is properly secured to the flex shaft (Fig. 9).

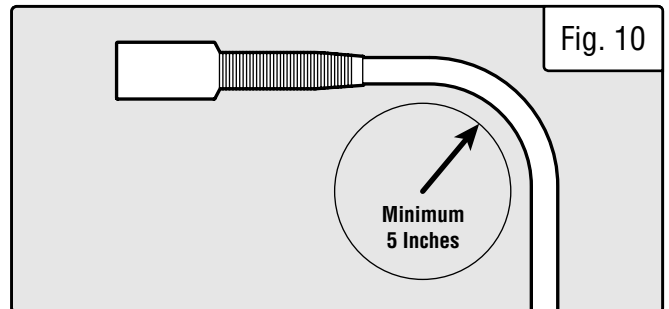

**Important:** Follow the rules below when using your flex shaft to prevent overheating the flex shaft and personal injuries.

- Lubricate your flex shaft regularly to prevent overheating (see p. 13).
- Do not bend the flex shaft near its connection to the rotary tool. Keep it straight.
- Never cross the flex shaft over itself during operation. Do not operate the flex shaft with a sharp bend. The recommended minimum radius for the flex shaft is 5 inches. Bending the shaft farther than this can generate excessive heat and damage the flex shaft.

## OPERATION

**⚠ WARNING!** Read and thoroughly understand all instructions and safety information before operating this rotary tool. Failure to do so may cause serious injury.

### ADJUSTING THE SPEED OF THE ROTARY TOOL

The variable speed adjustment dial on the top of the rotary tool is used to set the desired rotation speed. The speed for your rotary tool ranges from 8,000 to 30,000 RPM. To increase the speed, turn the wheel forward to a higher number. To decrease speed, turn the wheel backwards to a lower number.

Set suitable speed for your operation, workpiece and accessory:

- Use slow speeds for plastics, ceramics, precious metals and low-melting point materials to prevent damaging the material. All brushing applications and delicate polishing require slow rotary speeds at 15,000 RPM or less.
- Use higher speeds for wood, metal and glass. Drilling, carving, cutting, routing, shaping or rabbets are generally performed more efficiently at faster rotary speeds.

As a general rule, larger attachments should be used at a lower speed. The best way to determine the suitable speed is to test on a scrap piece of similar material, observe the results and adjust the speed accordingly.

### OPERATING THE ROTARY TOOL

As with all power equipment, a rotary tool can be dangerous if it is not assembled or used properly. Do not operate this power tool if you have doubts or questions regarding operation safety. Call our customer service department at **1-800-232-1195** M-F 8-5 CST to address your questions or concerns.

**⚠ WARNING!** Always wear safety glasses, safety gloves, safety shoes and suitable work clothing when operating this rotary tool. Do not wear jewelry, neckties or other loose clothing which could get caught in moving parts.

**⚠ WARNING!** Do not start or operate this tool in the presence of flammable liquids or gases.

1. Inspect the tool for any damage before use. Immediately discard any accessories with bent shafts or other significant damage. Make sure that the ventilation slots are not obstructed; failure to keep them clear may cause the tool to overheat.

2. The power switch is located on the underside of the handle. It has O (OFF) and I (ON) settings.

- To switch on the tool, flip it to I (the ON position).
- To switch off the tool, simply flip the switch to O (the OFF position). Be certain the tool is in the OFF position when not in use and during all maintenance activities.

3. Do not exert excessive pressure on your tool as it may damage your workpiece and the tool bit.

4. For milling and engraving operations, holding the rotary tool like a pen will yield better control. For heavier work like drilling, holding the tool like a hammer will yield better results.

5. Use the correct rotary bits for the job, and use the included dressing stone to sharpen or shape any attachments dulled by repeated use.

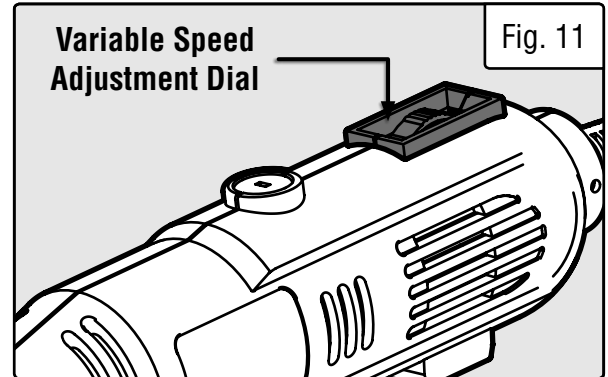

## MAINTENANCE

**⚠ WARNING!** Disconnect the rotary tool from the power supply before carrying out any adjustments, service or maintenance.

**IMPORTANT:** Servicing of the tool requires extreme care and knowledge and should be performed only by a qualified service technician.

### CLEANING AND INSPECTION

1. Always clean the tool and accessories after each use. Use a clean cloth and a soft brush to clean your tool.
2. **NEVER** use water or other liquids to clean the electrical portions of the tool.
3. Ensure that the ventilation slots are not blocked to prevent overheating.
4. Check the tools and accessories for any damage. Remove and dispose of damaged accessories.

### LUBRICATING THE FLEX SHAFT

The flex shaft's inner core rotates at high speed during operation, generating friction and heat. It is important to lubricate the inner core of your flex shaft after several hours of operation to prevent it from overheating. To lubricate the flex shaft, pull the inner core out from the flex shaft. Apply an even coat of multi-purpose grease onto the entire surface of the inner core. Insert the inner core back into the flex shaft.

### CARBON BRUSHES INSPECTION AND REPLACEMENT

To maintain efficiency of the motor, inspect the two carbon brushes routinely. The wear on the carbon brushes depends on how frequently and how heavily the tool is used. Replace the brushes when the brush length gets down to  $\frac{3}{16}$  of an inch or when the tool stops working. Replacement carbon brushes (Model 2307-010) can be ordered at [wenproducts.com](http://wenproducts.com).

1. Switch off and disconnect the tool from the power supply.
2. The carbon brush caps are located on the top and bottom of the rotary tool (Fig. 13 - 1). To access the brushes, unscrew and remove the two brush caps using the end of the wrench included with your tool kit.
3. Take out and inspect the carbon brushes (Fig. 14). If the brushes are worn to under  $\frac{3}{16}$  inch in length, replace them with new carbon brushes and reinstall the brush caps.

**NOTE:** Always keep carbon brushes clean and ensure that they slide freely in the brush holders. Both carbon brushes should be replaced at the same time.

### PRODUCT DISPOSAL

Used power tools contain recyclable materials and should not be disposed with household waste. Please take this product to your local recycling facility for responsible disposal and to minimize its environmental impact.

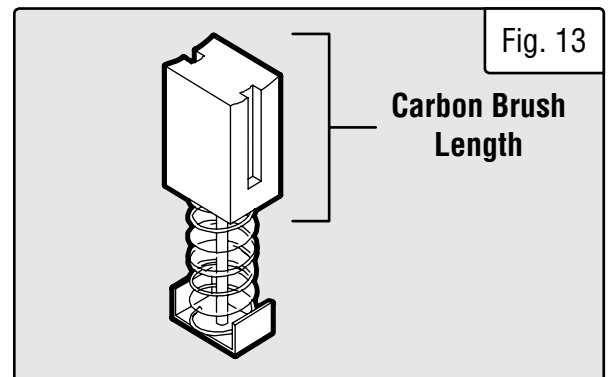
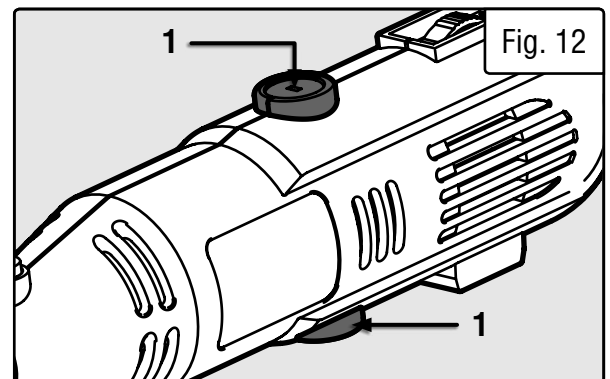

# **WARRANTY STATEMENT**

WEN Products is committed to building tools that are dependable for years. Our warranties are consistent with this commitment and our dedication to quality.

## **LIMITED WARRANTY OF WEN PRODUCTS FOR HOME USE**

GREAT LAKES TECHNOLOGIES, LLC (“Seller”) warrants to the original purchaser only, that all WEN consumer power tools will be free from defects in material or workmanship during personal use for a period of one (1) year from date of purchase or 250 hours of use; whichever comes first. Ninety days for all WEN products if the tool is used for professional or commercial use. Purchaser has 30 days from the date of purchase to report missing or damaged parts.

**SELLER’S SOLE OBLIGATION AND YOUR EXCLUSIVE REMEDY** under this Limited Warranty and, to the extent permitted by law, any warranty or condition implied by law, shall be the replacement of parts, without charge, which are defective in material or workmanship and which have not been subjected to misuse, alteration, careless handling, misrepair, abuse, neglect, normal wear and tear, improper maintenance, or other conditions adversely affecting the Product or the component of the Product, whether by accident or intentionally, by persons other than Seller. To make a claim under this Limited Warranty, you must make sure to keep a copy of your proof of purchase that clearly defines the Date of Purchase (month and year) and the Place of Purchase. Place of Purchase must be a direct vendor of Great Lakes Technologies, LLC. Purchasing through third party vendors, including but not limited to garage sales, pawn shops, resale shops, or any other secondhand merchant, voids the warranty included with this product. Contact [techsupport@wenproducts.com](mailto:techsupport@wenproducts.com) or 1-800-232-1195 with the following information to make arrangements: your shipping address, phone number, serial number, required part numbers, and proof of purchase. Damaged or defective parts and products may need to be sent to WEN before the replacements can be shipped out.

Upon the confirmation of a WEN representative, your product may qualify for repairs and service work. When returning a product for warranty service, the shipping charges must be prepaid by the purchaser. The product must be shipped in its original container (or an equivalent), properly packed to withstand the hazards of shipment. The product must be fully insured with a copy of the proof of purchase enclosed. There must also be a description of the problem in order to help our repairs department diagnose and fix the issue. Repairs will be made and the product will be returned and shipped back to the purchaser at no charge for addresses within the contiguous United States.

THIS LIMITED WARRANTY DOES NOT APPLY TO ITEMS THAT WEAR OUT FROM REGULAR USAGE OVER TIME, INCLUDING BELTS, BRUSHES, BLADES, BATTERIES, ETC. ANY IMPLIED WARRANTIES SHALL BE LIMITED IN DURATION TO ONE (1) YEAR FROM DATE OF PURCHASE. SOME STATES IN THE U.S. AND SOME CANADIAN PROVINCES DO NOT ALLOW LIMITATIONS ON HOW LONG AN IMPLIED WARRANTY LASTS, SO THE ABOVE LIMITATION MAY NOT APPLY TO YOU.

IN NO EVENT SHALL SELLER BE LIABLE FOR ANY INCIDENTAL OR CONSEQUENTIAL DAMAGES (INCLUDING BUT NOT LIMITED TO LIABILITY FOR LOSS OF PROFITS) ARISING FROM THE SALE OR USE OF THIS PRODUCT. SOME STATES IN THE U.S. AND SOME CANADIAN PROVINCES DO NOT ALLOW THE EXCLUSION OR LIMITATION OF INCIDENTAL OR CONSEQUENTIAL DAMAGES, SO THE ABOVE LIMITATION OR EXCLUSION MAY NOT APPLY TO YOU.

THIS LIMITED WARRANTY GIVES YOU SPECIFIC LEGAL RIGHTS, AND YOU MAY ALSO HAVE OTHER RIGHTS WHICH VARY FROM STATE TO STATE IN THE U.S., PROVINCE TO PROVINCE IN CANADA AND FROM COUNTRY TO COUNTRY.

THIS LIMITED WARRANTY APPLIES ONLY TO ITEMS SOLD WITHIN THE UNITED STATES OF AMERICA, CANADA AND THE COMMONWEALTH OF PUERTO RICO. FOR WARRANTY COVERAGE WITHIN OTHER COUNTRIES, CONTACT THE WEN CUSTOMER SUPPORT LINE. FOR WARRANTY PARTS OR PRODUCTS REPAIRED UNDER WARRANTY SHIPPING TO ADDRESSES OUTSIDE OF THE CONTIGUOUS UNITED STATES, ADDITIONAL SHIPPING CHARGES MAY APPLY.





**THANKS FOR  
REMEMBERING**  <sup>®</sup>