

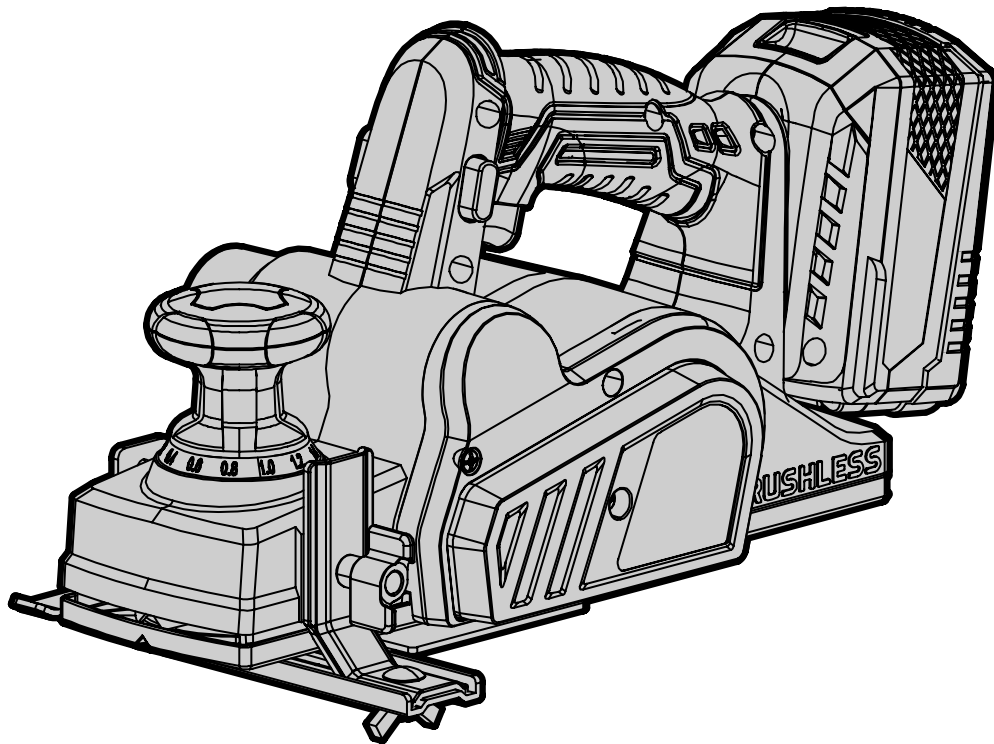

**MODEL 20653**

# **20V BRUSHLESS PLANER**

**Instruction Manual**



## **NEED HELP? CONTACT US!**

Have product questions? Need technical support? Please feel free to contact us:



**1-800-232-1195 (M-F 8AM-5PM CST)**



**TECHSUPPORT@WENPRODUCTS.COM**

**IMPORTANT:** Your new tool has been engineered and manufactured to WEN's highest standards for dependability, ease of operation, and operator safety. When properly cared for, this product will supply you years of rugged, trouble-free performance. Pay close attention to the rules for safe operation, warnings, and cautions. If you use your tool properly and for its intended purpose, you will enjoy years of safe, reliable service.

For replacement parts and the most up-to-date instruction manuals, visit ***WENPRODUCTS.COM***

# CONTENTS

<b>WELCOME</b>	<b>3</b>
Introduction .....	3
Specifications.....	3
<b>SAFETY</b>	<b>4</b>
General Safety Rules .....	4
Planer Safety Warnings.....	6
Electrical Information.....	7
Battery & Charger Safety Warnings .....	8
<b>BEFORE OPERATING</b>	<b>10</b>
Unpacking & Packing List.....	10
Know Your Planer .....	11
<b>OPERATION &amp; MAINTENANCE</b>	<b>12</b>
Operation .....	12
Adjustments.....	16
Maintenance.....	18
Exploded View & Parts List.....	19
Warranty Statement .....	21

To purchase accessories and replacement parts for your tool, visit **WENPRODUCTS.COM**

**20V 4.0Ah Max Battery** (Model 20204)  
**20V Charger** (Model 20200C)  
**TCT Planer Blades (6 Pack)** (Model 6530B-TCT)  
**6530 Planer Blades** (Model 6530B)  
**HSS Planer Blades (12 Pack)** (Model 6530B-12)

## INTRODUCTION

Thanks for purchasing the WEN Planer. We know you are excited to put your tool to work, but first, please take a moment to read through the manual. Safe operation of this tool requires that you read and understand this operator's manual and all the labels affixed to the tool. This manual provides information regarding potential safety concerns, as well as helpful assembly and operating instructions for your tool.

 Indicates danger, warning, or caution. The safety symbols and the explanations with them deserve your careful attention and understanding. Always follow the safety precautions to reduce the risk of fire, electric shock or personal injury. However, please note that these instructions and warnings are not substitutes for proper accident prevention measures.

**NOTE:** The following safety information is not meant to cover all possible conditions and situations that may occur. WEN reserves the right to change this product and specifications at any time without prior notice.

At WEN, we are continuously improving our products. If you find that your tool does not exactly match this manual, please visit [wenproducts.com](http://wenproducts.com) for the most up-to-date manual or contact our customer service at **1-800-232-1195**.

**Keep this manual available to all users during the entire life of the tool and review it frequently to maximize safety for both yourself and others.**

## SPECIFICATIONS

Model Number	20653
Included Battery	4.0Ah Battery (Model 20204)
Included Charger	20V, 2A DC (Model 20200C)
Rated Speed	13,000 RPM
Cutting Width	3-1/4 Inch (82mm)
Cutting Depth	0.07 Inch (2mm)
Rabbeting Depth	0.30 Inch (8mm)
Depth of Cut Increments	1/128 Inch (0.2mm)
Dust Port Diameter	Outer: 1-9/16 Inches (39.5mm)
	Inner: 1-5/16 Inches (33.5mm)
Product Weight	4.88 Pounds (Without Battery or Accessories)
Product Dimensions	11-1/4 in. x 5-1/2 in. x 7 in. (Without Battery or Accessories)
Battery Models	All WEN 20V MAX Batteries*
Charger Models	All WEN 20V MAX Chargers

**\*NOTE:** Some tools may not be compatible with WEN 20V MAX 1.5Ah Batteries, model 49120B. Contact WEN customer service at **1-800-232-1195**, M-F with questions.

WEN plans to continue to add more items to our 20V line. For an up-to-date list of the 20V cordless tools compatible with the included battery and charger, visit [wenproducts.com](http://wenproducts.com) and search model number 20202 (2Ah) or 20204 (4Ah). In the battery's description, there will be a list of current products that this battery can be used with.

# GENERAL SAFETY RULES

 **WARNING!** Read all safety warnings and all instructions. Failure to follow the warnings and instructions may result in electric shock, fire and/or serious injury.

Safety is a combination of common sense, staying alert and knowing how your item works. The term “power tool” in the warnings refers to your mains-operated (corded) power tool or battery-operated (cordless) power tool.

## SAVE THESE SAFETY INSTRUCTIONS.

### WORK AREA SAFETY

- 1. Keep work area clean and well lit.** Cluttered or dark areas invite accidents.
- 2. Do not operate power tools in explosive atmospheres, such as in the presence of flammable liquids, gases or dust.** Power tools create sparks which may ignite the dust or fumes.
- 3. Keep children and bystanders away while operating a power tool.** Distractions can cause you to lose control.

### ELECTRICAL SAFETY

- 1. Power tool plugs must match the outlet. Never modify the plug in any way. Do not use any adapter plugs with earthed (grounded) power tools.** Unmodified plugs and matching outlets will reduce risk of electric shock.
- 2. Avoid body contact with earthed or grounded surfaces such as pipes, radiators, ranges and refrigerators.** There is an increased risk of electric shock if your body is earthed or grounded.
- 3. Do not expose power tools to rain or wet conditions.** Water entering a power tool will increase the risk of electric shock.
- 4. Do not abuse the cord. Never use the cord for carrying, pulling or unplugging the power tool. Keep cord away from heat, oil, sharp edges or moving parts.** Damaged or entangled cords increase the risk of electric shock.
- 5. When operating a power tool outdoors, use an extension cord suitable for outdoor use.** Use of a cord suitable for outdoor use reduces the risk of electric shock.

- 6. If operating a power tool in a damp location is unavoidable, use a ground fault circuit interrupter (GFCI) protected supply.** Use of a GFCI reduces the risk of electric shock.

### PERSONAL SAFETY

- 1. Stay alert, watch what you are doing and use common sense when operating a power tool. Do not use a power tool while you are tired or under the influence of drugs, alcohol or medication.** A moment of inattention while operating power tools may result in serious personal injury.
- 2. Use personal protective equipment. Always wear eye protection.** Protective equipment such as a respiratory mask, non-skid safety shoes and hearing protection used for appropriate conditions will reduce the risk of personal injury.
- 3. Prevent unintentional starting. Ensure the switch is in the off-position before connecting to power source and/or battery pack, picking up or carrying the tool.** Carrying power tools with your finger on the switch or energizing power tools that have the switch on invites accidents.
- 4. Remove any adjusting key or wrench before turning the power tool on.** A wrench or a key left attached to a rotating part of the power tool may result in personal injury.
- 5. Do not overreach. Keep proper footing and balance at all times.** This enables better control of the power tool in unexpected situations.
- 6. Dress properly. Do not wear loose clothing or jewelry. Keep your hair and clothing away from moving parts.** Loose clothes, jewelry or long hair can be caught in moving parts.

# GENERAL SAFETY RULES

**⚠ WARNING!** Read all safety warnings and all instructions. Failure to follow the warnings and instructions may result in electric shock, fire and/or serious injury.

Safety is a combination of common sense, staying alert and knowing how your item works. The term “power tool” in the warnings refers to your mains-operated (corded) power tool or battery-operated (cordless) power tool.

## SAVE THESE SAFETY INSTRUCTIONS.

**7. If devices are provided for the connection of dust extraction and collection facilities, ensure these are connected and properly used.** Use of dust collection can reduce dust-related hazards.

### POWER TOOL USE AND CARE

**1. Do not force the power tool. Use the correct power tool for your application.** The correct power tool will do the job better and safer at the rate for which it was designed.

**2. Do not use the power tool if the switch does not turn it on and off.** Any power tool that cannot be controlled with the switch is dangerous and must be repaired.

**3. Disconnect the plug from the power source and/or the battery pack from the power tool before making any adjustments, changing accessories, or storing power tools.** Such preventive safety measures reduce the risk of starting the power tool accidentally.

**4. Store idle power tools out of the reach of children and do not allow persons unfamiliar with the power tool or these instructions to operate the power tool.** Power tools are dangerous in the hands of untrained users.

**5. Maintain power tools. Check for misalignment or binding of moving parts, breakage of parts and any other condition that may affect the power tool's operation. If damaged, have the power tool repaired before use.** Many accidents are caused by poorly maintained power tools.

**6. Keep cutting tools sharp and clean.** Properly maintained cutting tools with sharp cutting edges are less likely to bind and are easier to control.

**7. Use the power tool, accessories and tool bits, etc. in accordance with these instructions, taking into account the working conditions and the work to be performed.** Use of the power tool for operations different from those intended could result in a hazardous situation.

**8. Use clamps to secure your workpiece to a stable surface.** Holding a workpiece by hand or using your body to support it may lead to loss of control.

**9. KEEP GUARDS IN PLACE** and in working order.

### SERVICE

**1. Have your power tool serviced by a qualified repair person using only identical replacement parts.** This will ensure that the safety of the power tool is maintained.

### CALIFORNIA PROPOSITION 65 WARNING

Some dust created by power sanding, sawing, grinding, drilling, and other construction activities may contain chemicals, including lead, known to the State of California to cause cancer, birth defects, or other reproductive harm. Wash hands after handling. Some examples of these chemicals are:

- Lead from lead-based paints.
- Crystalline silica from bricks, cement, and other masonry products.
- Arsenic and chromium from chemically treated lumber.

Your risk from these exposures varies depending on how often you do this type of work. To reduce your exposure to these chemicals, work in a well-ventilated area with approved safety equipment such as dust masks specially designed to filter out microscopic particles.

# PLANER SAFETY WARNINGS

 **WARNING!** Do not operate the power tool until you have read and understood the following instructions and the warning labels.

## WORKPIECE SAFETY

1. Secure the workpiece to a stable platform using clamps or another practical method. Never hold it in your hand or across your legs. Unstable support could result in a loss of control and personal injury.
2. Small workpieces must be adequately secured so that the rotating planer blades don't pick them up during the forward motion of the planer.
3. Check the workpiece for nails and other foreign objects. If there are nails, either remove them or set them well below the intended finished surface. Any article that encounters planer blades may be forcibly ejected from planer creating risk of injury.

## OPERATION SAFETY

1. Always use ANSI Z87.1 approved safety glasses. Wear hearing protection to prevent hearing damage during operation. Use face mask or dust mask if cutting operation is dusty.
2. Keep handles and hands dry, clean and free from oil and grease. Slippery surfaces can cause you to lose control of the power tool.
3. Always hold the planer firmly with both hands for maximum control.
4. Only hold the power tool by insulated gripping surfaces in case the cutter contacts its own cord. Cutting a "live" wire may make exposed metal parts of the tool "live" and could give the operator an electric shock.
5. Always start the planer before the blade is in contact with the workpiece. Let the blade reach full speed before using the tool. The planer can vibrate and possibly kick back if the cutting speed is too slow.
6. Do not plane end grain, as the wood could splinter or possibly explode. Always plane along the grain direction of the wood. Never plane against the grain direction.

7. Never pull the planer backwards over the workpiece. Loss of control may occur.
8. Do not put fingers or any objects into the chip extraction port.
9. Remove the plug from power source before removing chips. Do not clean out chips while the tool is running. Contact with the cutterhead will cause injury as the blades are hidden from view and you may be cut if the blade is contacted.
10. Wait for the cutter to stop before setting the tool down. An exposed rotating cutter may engage the surface, leading to possible loss of control and serious injury.

## MAINTENANCE SAFETY

1. Unplug the planer before making adjustments or changing accessories. Accidental start-ups may occur if the planer is plugged in during an accessory change.
2. Planer blades are sharp. Wear protective work gloves when removing / installing blades or turning the cutterhead.
3. After changing blades, rotate the cutterhead to make sure the blades don't hit any part of the cutterhead housing and that the blade locking screws are tight. Loose or misaligned blades have the potential to damage the tool and cause possible injury.
4. Develop a periodic maintenance schedule for your tool. When cleaning be careful not to disassemble any portion of the tool. Internal wires may be misplaced or pinched and safety guard return springs may be improperly mounted.
5. Certain cleaning agents such as gasoline, carbon tetrachloride, ammonia, etc. may damage plastic parts.

## ELECTRICAL INFORMATION (CHARGER)

### DOUBLE-INSULATED CHARGER

The charger's electrical system is double-insulated where two systems of insulation are provided. This eliminates the need for the usual three-wire grounded power cord. Double-insulated tools do not need to be grounded, nor should a means for grounding be added to the product. All exposed metal parts are isolated from the internal metal components with protecting insulation.

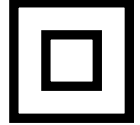

**IMPORTANT:** Servicing a double-insulated product requires extreme care and knowledge of the system, and should be done only by qualified service personnel using identical replacement parts. Always use original factory replacement parts when servicing.

**1. Polarized Plugs.** To reduce the risk of electric shock, this equipment has a polarized plug (one blade is wider than the other). This plug will fit in a polarized outlet only one way. If the plug does not fit fully in the outlet, reverse the plug. If it still does not fit, contact a qualified electrician to install a proper outlet. Do not modify the machine plug or the extension cord in any way.

**2. Ground fault circuit interrupter protection (GFCI)** should be provided on the circuit or outlet used for this power tool to reduce the risk of electric shock.

**3. Service and repair.** To avoid danger, electrical appliances must only be repaired by a qualified service technician using original replacement parts.

### GUIDELINES AND RECOMMENDATIONS FOR EXTENSION CORDS

When using an extension cord, be sure to use one heavy enough to carry the current your product will draw. An undersized cord will cause a drop in line voltage, resulting in loss of power and overheating. The table below shows the correct size to be used according to cord length and ampere rating. When in doubt, use a heavier cord. The smaller the gauge number, the heavier the cord.

AMPERAGE	REQUIRED GAUGE FOR EXTENSION CORDS			
	25 ft.	50 ft.	100 ft.	150 ft.
2A	18 gauge	16 gauge	16 gauge	14 gauge

**1. Examine extension cord before use.** Make sure your extension cord is properly wired and in good condition. Always replace a damaged extension cord or have it repaired by a qualified person before using it.

**2. Do not abuse extension cord.** Do not pull on cord to disconnect from receptacle; always disconnect by pulling on plug. Disconnect the extension cord from the receptacle before disconnecting the product from the extension cord. Protect your extension cords from sharp objects, excessive heat and damp/wet areas.

**3. Use a separate electrical circuit for your tool.** This circuit must not be less than a 12-gauge wire and should be protected with a 15A time-delayed fuse. Before connecting the motor to the power line, make sure the switch is in the OFF position and the electric current is rated the same as the current stamped on the motor nameplate. Running at a lower voltage will damage the motor.



## BATTERY & CHARGER SAFETY WARNINGS

Despite all of the safety precautions, caution must always be taken when handling batteries. The following points must be obeyed at all times to ensure safe use. Safe use can only be guaranteed if undamaged cells are used. Incorrect handling of the battery pack can cause cell damage.

- **Avoid dangerous environments** – Do not charge the battery pack in rain, snow or in damp or wet locations. Do not use the battery pack or charger in the presence of explosive atmospheres (gaseous fumes, dust or flammable materials) because sparks may be generated when inserting or removing the battery pack, which could lead to a fire.

- **Charge in a well-ventilated area** – Do not block the charger vents. Keep them clear to allow for proper ventilation. Do not allow smoking or open flames near a charging battery pack. Vented gases may explode.

**NOTE:** The safe temperature range for the battery charging is -4°F to 113°F. Do not charge the battery outside in freezing weather; charge it at room temperature.

- **Maintain charger cord** – When unplugging the charger, pull the plug, not the cord, from the receptacle to reduce the risk of damage to the electrical plug and cord. Never carry the charger by its cord or yank it by the cord to disconnect it from the receptacle. Keep the cord away from heat, oil and sharp edges. Make sure the cord will not be stepped on, tripped over or subjected to damage or stress when the charger is in use. Do not use the charger with a damaged cord or plug. Replace a damaged charger immediately.

- **Do not use an extension cord unless it is absolutely necessary** – Using the wrong, damaged or improperly wired extension cord poses a risk of fire and electric shock. If an extension cord must be used, plug the charger into a properly wired 16 gauge or larger extension cord with the female plug matching the male plug on the charger. Make sure that the extension cord is in good electrical condition.

- **Charger is rated for 120 volt AC only** – The charger must be plugged into an appropriate receptacle.

- **Use only recommended attachments** – Use of an attachment not recommended or sold by WEN Products may result in risk of fire, electric shock or personal injury.

- **Unplug charger when not in use** – Make sure to remove battery packs from unplugged chargers.

 **WARNING!** To reduce the risk of electric shock, always unplug the charger before performing any cleaning or maintenance. Do not allow water to flow into the charger. Use a Ground Fault Circuit Interrupter (GFCI) to reduce shock hazards.

- **Do not burn or incinerate battery packs** – Battery packs may explode, causing personal injury or damage. Toxic fumes and materials are created when battery packs are burned.

- **Do not crush, drop or damage battery packs** – Do not use the battery pack or charger if they have sustained a sharp blow, been dropped, run over or have been damaged in any way (i.e. pierced with a nail, hit with a hammer, stepped on, etc.).

- **Do not disassemble** – Incorrect reassembly may pose a serious risk of electric shock, fire or exposure to toxic battery chemicals. If the battery or charger are damaged, call WEN customer service at **1-800-232-1195** for assistance.

- **Battery chemicals cause serious burns** – Never let a damaged battery pack contact the skin, eyes or mouth. If a damaged battery pack leaks battery chemicals, use rubber or neoprene gloves to safely dispose of it. If skin is exposed to battery fluids, wash the affected area with soap and water and rinse with vinegar. If eyes are exposed to battery chemicals, immediately flush with water for 20 minutes and seek medical attention. Remove and dispose of contaminated clothing.

- **Store your battery pack and charger in a cool, dry place** – Do not store the battery pack or charger where temperatures may exceed 104 °F, such as in direct sunlight or inside a vehicle or metal building during the summer.

- **Do not short circuit** – A battery pack will short circuit if a metal object makes a connection between the positive and negative contacts on the battery pack. Do not place a battery pack near anything that may cause a short circuit, such as paper clips, coins, keys, screws, nails and other metallic objects. A short-circuited battery pack poses a risk of fire and severe personal injury.



# **BATTERY & CHARGER SAFETY WARNINGS**

## **ABOUT THE BATTERY**

1. The battery pack has to be charged completely before you use the tool for the first time.
2. For optimum battery performance, avoid low discharge cycles by charging the battery pack frequently.
3. Lithium-ion batteries are subject to a natural aging process. The battery pack must be replaced at the latest when its capacity falls to just 80% of its capacity when new. Weakened cells in an aged battery pack are no longer capable of meeting the high power requirements needed for the proper operation of your tool, and therefore pose a safety risk.
4. Do not throw battery packs into an open fire as this poses a risk of explosion. Do not ignite the battery pack or expose it to fire.
5. Do not exhaustively discharge batteries. Exhaustive discharge will damage the battery cells. The most common cause of exhaustive discharge is lengthy storage or non-use of partially discharged batteries. Stop working as soon as the performance of the battery falls noticeably or the electronic protection system triggers. Place the battery pack in storage only after it has been fully charged.
6. Protect batteries and the tool from overloads. Overloads will quickly result in overheating and cell damage inside the battery housing even if this overheating is not apparent externally.
7. Avoid damage and shocks. Immediately replace batteries that have been dropped from a height of more than one meter or those that have been exposed to violent shocks, even if the housing of the battery pack appears to be undamaged. The battery cells inside the battery may have suffered serious damage. In such instances, please read the waste disposal information for proper battery disposal.
8. If the battery pack suffers overloading and overheating, the integrated protective cutoff will switch off the equipment for safety reasons.
9. Use only original battery packs. The use of other batteries poses a fire risk and may result in injuries or an explosion.

## **ABOUT THE CHARGER**

Protect battery charger and cord from damage. Keep the charger and its cord away from heat, oil and sharp edges.

Electrical plugs must match the outlet. Never modify the plug in any way. Do not use any adapter plugs with grounded appliances. Unmodified plugs and matching outlets will reduce the risk of electric shock.

Keep the battery charger, battery pack(s), and the cordless tool out of the reach of children.

Do not use the supplied battery charger to charge other cordless tools.

During periods of heavy use, the battery pack will become warm. Allow the battery pack to cool to room temperature before inserting it into the charger to recharge.

Do not overcharge batteries. Do not exceed the maximum charging times. These charging times only apply to discharged batteries. Frequent insertion of a charged or partially charged battery pack will result in overcharging and cell damage. Do not leave battery in the charger for days on end.

Never use or charge a battery if you suspect that it has been more than 12 months since last time they were charged. There is a high probability that battery pack has already suffered dangerous damage (exhaustive discharge).

Do not use battery that have been exposed to heat during the charging process, as the battery cells may have suffered dangerous damage.

Do not use battery that have suffered curvature or deformation during the charging process or those that exhibit other atypical symptoms (gassing, hissing, cracking, etc.)

# UNPACKING & PACKING LIST

## UNPACKING

Carefully remove the planer from the packaging and place it on a sturdy, flat surface. Make sure to take out all contents and accessories. Do not discard the packaging until everything is removed. Check the packing list below to make sure you have all of the parts and accessories. If any part is missing or broken, please contact customer service at **1-800-232-1195** (M-F 8-5 CST), or email [techsupport@wenproducts.com](mailto:techsupport@wenproducts.com).

### Components

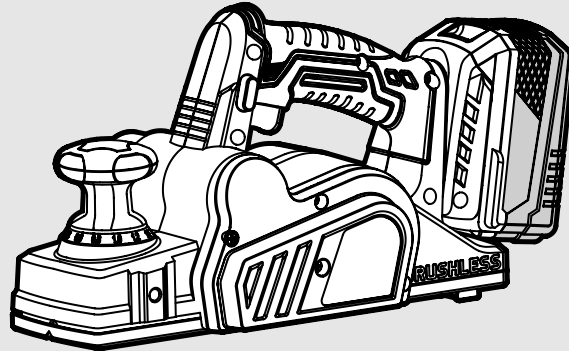

**Planer**

### Accessories

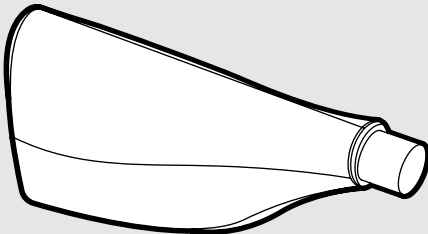

**Dust Bag**

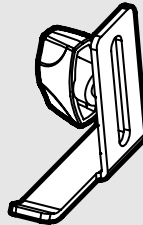

**Rabbeting Depth Stop**

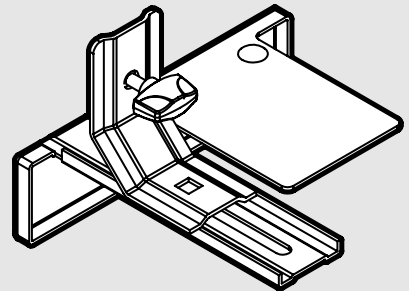

**Parallel Guide Fence**

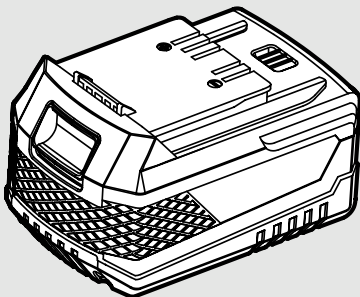

**20V Battery (1)**

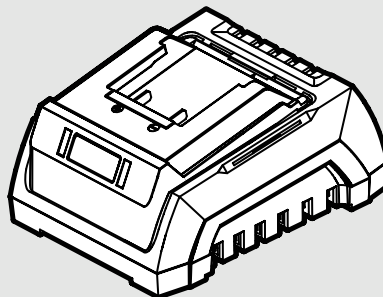

**20V Charger (1)**

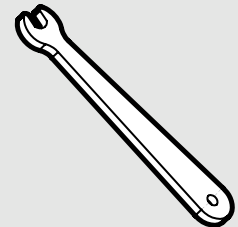

**Wrench (1)**

# KNOW YOUR PLANER

## TOOL PURPOSE

The power to trim doors, flatten boards, and much more is in the palm of your hand with your WEN Planer. Refer to the following diagrams to become familiarized with all the parts and controls of your planer. The components will be referred to later in the manual for assembly and operation instructions.

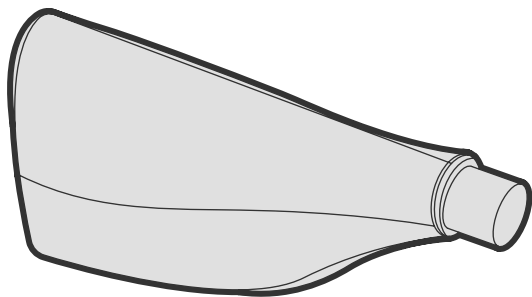
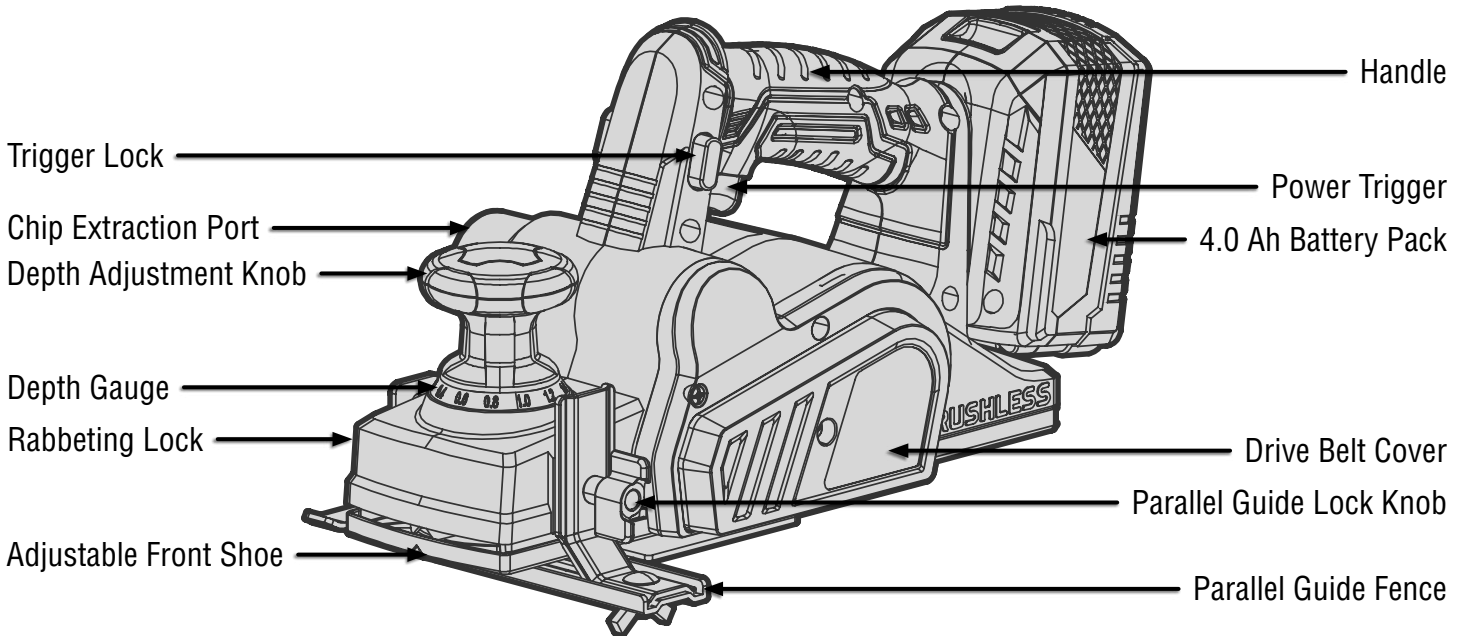

Dust Bag

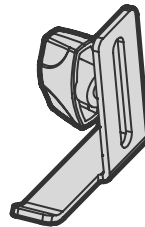

Rabbeting Depth Stop

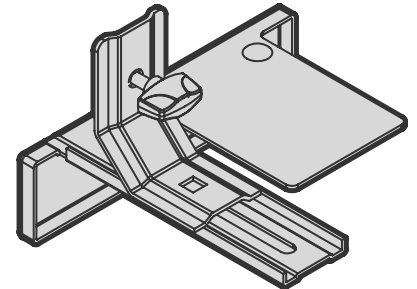

Parallel Guide Fence

## OPERATION

**⚠ WARNING!** To prevent serious injury, make sure all the instructions have been read and understood before operating this tool. Before plugging the machine into the power supply, always check that the trigger switch and trigger lock work properly.

### USING THE SAFETY KICKSTAND

The safety kickstand (Fig. 1 - 1) on the back of the planer swings down to help keep the blade from coming into contact with the work surface when the planer is not in use.

To use the safety kickstand when the planer is not in use, slide the stand until it springs out. Push the kickstand back into the slot and slide it back until it locks into place before operating the planer.

### CONNECTING THE DUST BAG

If desired, attach the dust bag by sliding the nozzle onto the chip extraction port (Fig. 2 - 1). For efficient operation, empty the dust bag when it is no more than half full, allowing for better airflow through the bag.

You can also connect your planer to a suitable dust extraction system through the extraction port. Hose adaptors (not included) may be needed depending on the size of your dust hose. The chip extraction port's outer diameter is 1-9/16" (39.5mm); the inner diameter is 1-5/16" (33.5mm).

**⚠ WARNING!** Shavings may jam in the dust extraction port when cutting damp wood. Never stick your finger into the dust extraction port. Clean out the shavings with a stick, but only when the cutter has stopped running and the tool has been unplugged from the power source.

### SWITCHING ON AND OFF

The tool is equipped with a trigger lock (Fig. 3 - 1) to avoid unintentional start-ups.

1. To turn the planer on, press the trigger lock (Fig. 3 - 1) and then squeeze the trigger switch (Fig. 3 - 2).
2. To switch off, release the trigger switch.

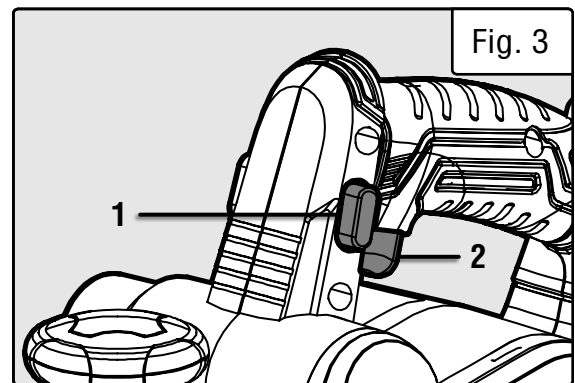
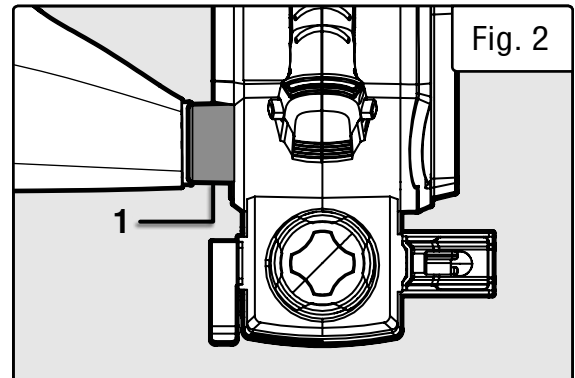
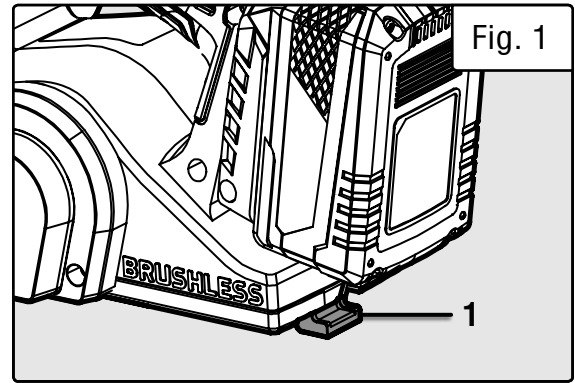

## OPERATION

### ADJUSTING THE CUTTING DEPTH

The planer's cutting depth is determined by the height difference between the adjustable front shoe and the cutting edge of the blade. The depth adjustment knob moves the front shoe to adjust how much blade is exposed, which determines the amount of material that will be removed. To adjust the cutting depth:

Rotate the depth adjustment knob (Fig. 4 - 1) until the indicator arrow (Fig. 4 - 2) aligns with the desired cutting depth on the depth gauge (Fig. 4 - 3). Turn the depth adjustment knob clockwise for a deeper cut and counterclockwise for a shallower cut.

**NOTE:** The minimum cutting increment is 1/128 inch (0.2 mm). The maximum cutting depth of the planer is 0.07 inch (2mm). However, the more material you attempt to take off with each pass, the less even the final board will be. The appropriate cutting depth depends on the material of your workpiece. For optimum planing performance, the maximum cutting depth should be 1/64 inch. Make multiple, progressive cuts of 1/64 inch or less to achieve the final depth of cut. To accurately determine the depth of cut, plane a similar piece of scrap material and adjust the settings accordingly.

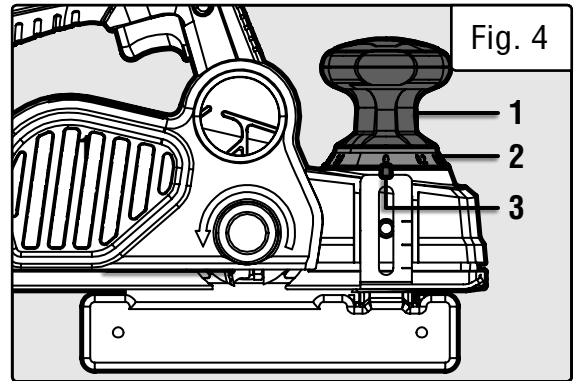

**! CAUTION!** Always ensure that the number on the depth gauge is at the “0” position when the tool is not in use. However, even at “0”, a slightly protruding blade could still make contact, depending on how the blade was installed. Engage the safety kickstand to prevent the blade from contacting the workpiece.

### THE DO'S AND DONT'S OF GRAIN DIRECTION

Always plane with the grain of the wood (in the same direction as the grain) (Fig. 5). There are six sides to every board: two face grains, two side/edge grains, and two end grains. You can plane face grain or side/edge grain, but DO NOT plane end grain. Otherwise, the board has a chance of splintering and exploding inside of the planer, which could cause serious injury and damage.

When planing the face and side/edge grain, always plane in the direction of the grain. Do not plane perpendicular to the grain, otherwise the board also has a chance of splintering and exploding.

**! WARNING!** Never plane against the grain direction of the wood. Do not plane end grain, as the wood could splinter or possibly explode.

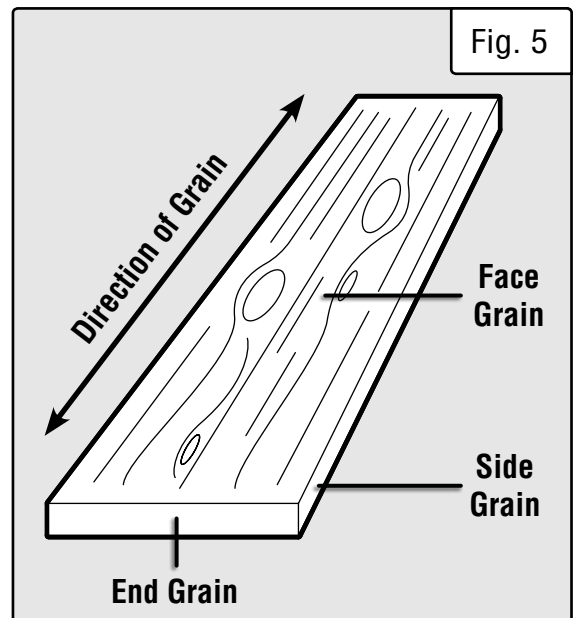

### DETERMINING THE FEED RATE

The proper feed rate will depend on the type of material being cut and the depth of the cut. Moving the planer too fast may cause a poor quality of cut and can damage the blades or the motor; moving the machine too slowly may burn or mar the cut. Practice first on a scrap piece of material to gauge the correct feed rate and cutting dimensions.

## OPERATION

**⚠ WARNING!** Wear safety goggles at all times that comply with ANSI Z87.1. Use ear protection such as plugs or muffs during extended periods of operation. Wear a face mask or dust mask to fight the dust.

### OPERATING YOUR PLANER

1. Secure the workpiece to a stable platform. Make sure that the surface to be planed is face grain or side grain. Do not plane end grain, as the wood could splinter or possibly explode (see “The Do’s and Dont’s of Grain Direction”).
2. Hold the planer firmly with both hands. Rest the front shoe flat on the workpiece surface, ensuring that the blades do not make contact with the workpiece.
3. Switch the tool ON and wait for the blades to reach full speed.
4. Move the tool gently forward along the grain of the wood. Apply pressure on the front of the tool at the beginning of planing, and at the rear of the tool towards the end of the planing stroke.
5. Push the planer beyond the edge of the workpiece without tilting it downwards. Turn off the planer and wait for the cutter to stop before setting the tool down.

**NOTE:** The feed rate and the depth of cutting determine the quality of the finish. Increase the depth of cut for rough cutting and reduce the depth of the cut to achieve a smoother finish.

**⚠ CAUTION!** The motor may stall if improperly used or overloaded. Reduce the pressure (feed rate) or the depth of cut to prevent possible damage to the tool if the motor labors.

### MAKING A CHAMFER CUT

The V-groove in the front shoe lets you cut chamfers quickly and easily. Chamfers are small bevels along the edges of your workpiece.

1. Make sure that the workpiece is secured to a stable platform.
2. Hold the planer firmly with both hands. Align the V-groove in the front shoe of the planer with the corner edge of the workpiece (Fig. 6). Be sure the blades are not touching the work. Place weight on the depth adjustment knob so that the V-groove is absolutely flat on the edge to be beveled.
3. Switch the tool ON and wait for the blades to reach full speed.
4. Push the planer forward along the grain of the wood with steady pressure on the front shoe.
5. Push the planer beyond the edge of the workpiece without tilting it downwards. Turn off the planer and wait for the cutter to stop before setting the tool down.

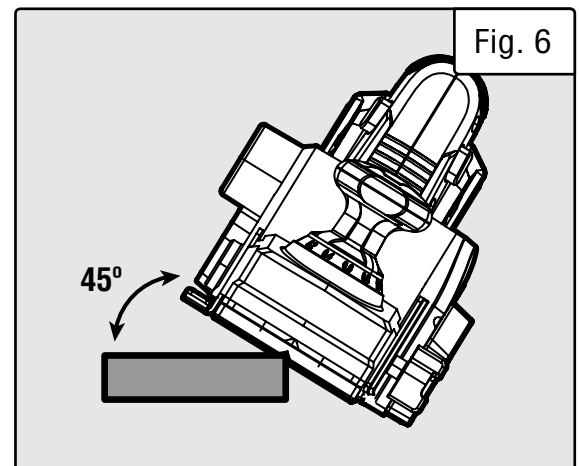



## OPERATION

**⚠ WARNING!** To avoid injury from accidental startups, always ensure that the tool is switched OFF and unplugged from the power supply before making any adjustments to the planer.

### USING THE PARALLEL GUIDE FENCE

The parallel guide fence ensures that the planer travels parallel to the edge of the wood, providing a straight cut at your desired cutting width. This feature is helpful for planing door edges, wood trim and boards. To attach the parallel guide fence:

1. Disconnect the planer from the power source.
2. Attach the parallel guide fence to the left-hand side of the planer using the lock knob (Fig. 7 - 1).
3. Loosen the wing nut (Fig. 8 - 1) on the parallel guide fence and slide the fence to set the desired cutting width indicated by the ruler on the fence. Tighten the wing nut.

**NOTE:** To ensure a square cut, measure the front and back of the fence and use a square to make sure the guide is set straight.

4. Rest the front shoe flat on workpiece surface and position fence firmly against edge of the workpiece (Fig. 8). Follow instructions on p. 10 “Operating your Planer” to perform your cut.

### USING THE RABBETING DEPTH GUIDE

A rabbet is a step-shaped cut made in the edge or face of a workpiece, used to join one workpiece with another, and unfortunately bearing no resemblance to the fuzzy creature. The rabbeting depth guide can be adjusted anywhere from 0 to 7/10 of an inch above the base of the planer.

1. Disconnect the planer from the power source.
2. Attach the rabbeting depth gauge to the right-hand side of the planer using the lock knob (Fig. 9 - 1). Position the rabbeting depth gauge to the desired height against the depth indication mark on the side housing. Tighten the lock knob.
3. If desired, use the parallel guide fence in conjunction with the rabbeting depth guide to create a straight rabbeting cut.
4. Make multiple progressive cuts to achieve the total cutting depth. The required rabbeting depth is achieved when the depth gauge is flush with the unplanned section of the workpiece to the right-hand side of the tool (Fig. 10).

**NOTE:** The rabbeting depth gauge allows only approximate depth settings. If it is necessary to rabbet to a precise depth, plane a scrap piece of wood, measure the rabbeted depth, and adjust the setting as necessary.

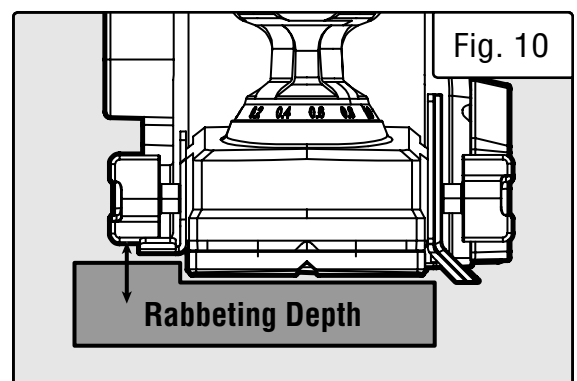
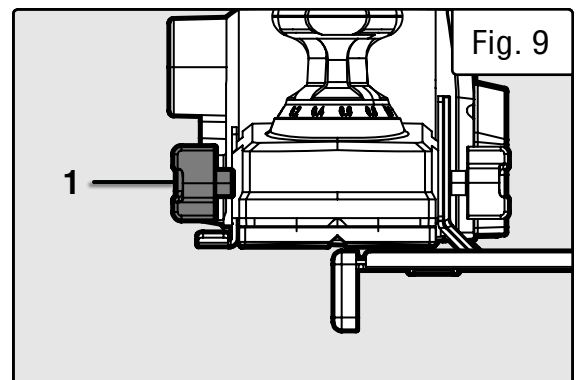
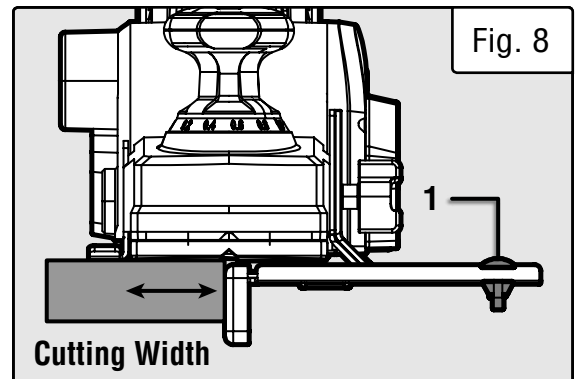
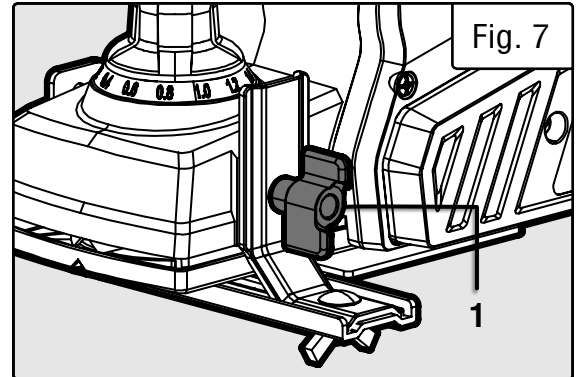

## ADJUSTMENTS

**⚠ WARNING!** To avoid injury from accidental startups, always ensure that the tool is switched OFF and unplugged from the power supply before making adjustments or installing or removing blades.

### REMOVING OR INSTALLING PLANER BLADES

**⚠ WARNING!** Planer blades are sharp and fragile. Wear protective gloves to protect your hands. Handle the blades carefully to avoid personal injury or damage to the blades.

**⚠ WARNING!** Do not attempt to sharpen or use resharpened blades of any kind. Use only blades designated for use with this model. Other blades may not clamp securely in the blade holder, causing vibration and a decrease in performance.

The blades' condition will affect cutting precision. Observe the quality of the cut that the planer produces to check the condition of the blades. Dull blades will tear wood fibers and produce fuzzy surfaces. Raised grain will occur on the wood when the cutting blades are dull or nicked.

**NOTE:** Blades on this planer are reversible and should always be reversed or replaced as a matched set. Unbalanced blades can cause vibration and poor planing action while shortening the life of the blade and the tool. Keeping a spare set of blades on hand is recommended. Different types of replacement blades can be ordered at [wenproducts.com](http://www.wenproducts.com) by searching "6530B". Blades are a wear-out part and as such are not covered by the warranty.

1. Disconnect planer from power source. Set the cutting depth to 0.
2. Put planer on a secure work surface and turn it upside down. Carefully rotate cutterhead to expose clamping screws (Fig.11 - 1).
3. Loosen the three clamping screws using the onboard blade wrench located on the back of the planer (Fig. 12).

**CAUTION:** The cutterhead can rotate as you are changing blades, so be careful not to contact the blade with your hand. If the screw is difficult to loosen, try tightening it a little and then loosen it.

4. Hold the cutterhead in place and carefully slide the blade (Fig. 13 - 1) out towards the blade guard side. You can also use a wooden block to push the blade out of the cutterhead.

5. Clean out all chips or foreign matter adhering to cutterhead and blade using a soft brush or compressed air.
6. Each planer blade has two cutting edges and may be reversed when one cutting edges becomes dull or chipped.
  - If one edge is dull, reverse the blade.
  - If both edges are dull, remove the old blade and replace it with a new one.

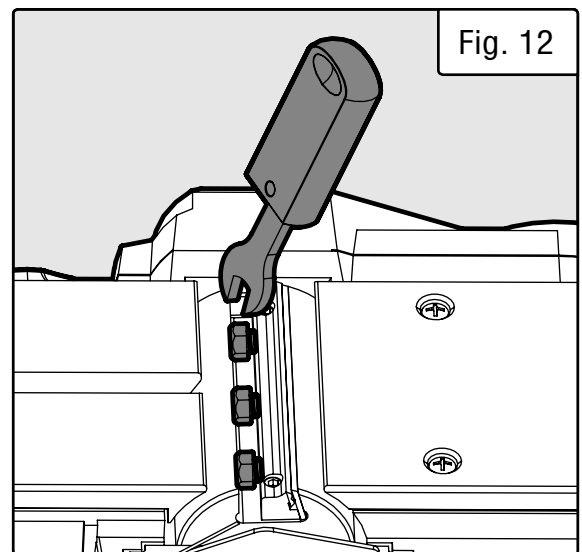
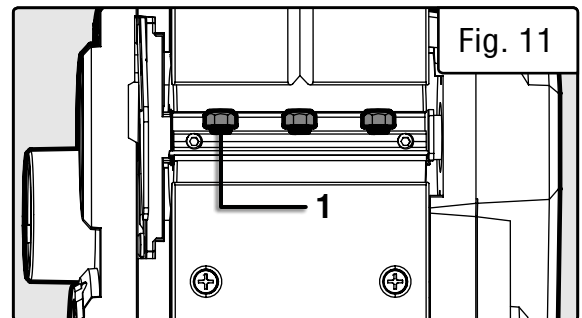

## ADJUSTMENTS

**⚠ WARNING!** To avoid injury from accidental startups, always ensure that the tool is switched OFF and unplugged from the power supply before making adjustments or installing or removing blades.

7. Slide the blade with the good side up into the blade retainer of the cutterhead (Fig. 13).

**NOTE:** The flat side of the blade should be facing the front of the planer and the ridged side of the blade should be facing the back of the planer.

8. To ensure an even cut, the blade should align with the outside edge of the front and rear shoes. Place a straight edge along the outside edge of the front and rear shoe (Fig. 14). Slide the planer blade to just contact the straight edge so that it is in line with the outside edge of the shoes.

9. The blades must be mounted so that the cutting edge is absolutely level (parallel to the surface of the rear shoe). Check that both ends of the blade protrude out evenly from the blade retainer of the cutterhead.

**NOTE:** The planed surface will end up rough and uneven if blades are not set properly or securely.

10. Tighten the clamping screws using the blade wrench, ensuring that all three screws are tightened evenly (Fig 15).

11. Repeat steps 2 - 10 for the installing/changing the second blade. It is important to reverse or replace the two blades at the same time so they are balanced with one another. Both blades should be set to the same cutting level and alignment, otherwise the planed surface will be rough and uneven.

**⚠ CAUTION!** Tighten all clamping screws carefully when attaching the blades to the planer. A loose clamping screw can be extremely dangerous. Check regularly to make sure that all six clamping screws are tightened securely.

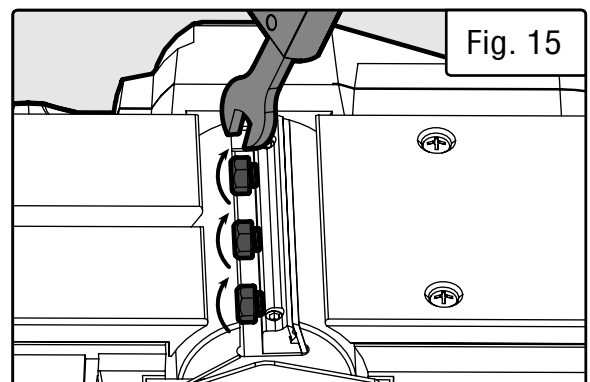
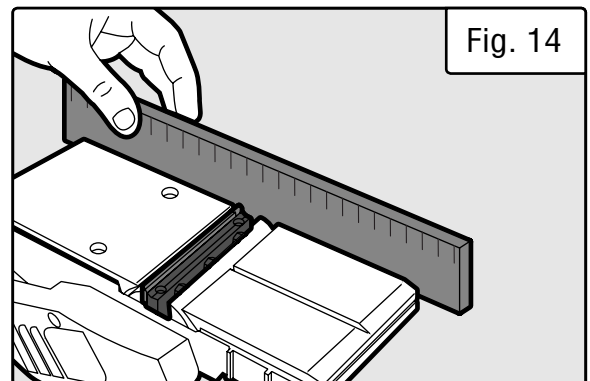
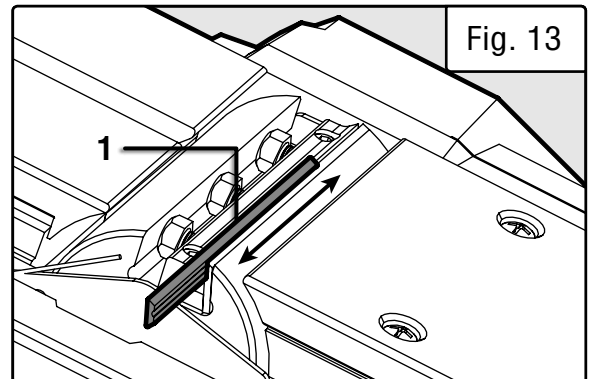

## MAINTENANCE

**⚠ WARNING!** To prevent serious injury from accidental operation, make sure that the planer is turned off and unplugged from power source before installation, cleaning and maintenance operations.

**⚠ WARNING!** Preventive maintenance performed by unauthorized personnel may result in misplacing of internal wires and components, possibly causing a serious hazard.

### CLEANING

Keep the planer clean of any wood chips, dust, dirt or debris. Ventilation openings and switch levers must be kept clean and free of foreign matter. The tool may be cleaned most effectively with compressed dry air. Always wear safety goggles when cleaning tools with compressed air. Do not attempt to clean these components by inserting pointed objects through openings.

**⚠ WARNING!** Certain cleaning agents and solvents damage plastic parts. This includes but is not limited to gasoline, carbon tetrachloride, chlorinated cleaning solvents, ammonia and household detergents that contain ammonia.

### TOOL LUBRICATION

Your tool has been properly lubricated and is ready to use. The bearings on your planer are permanently shielded and lubricated, and require no additional maintenance.

### DRIVE BELT

Inspect drive belt every 60 hours of use. If the drive belt shows signs of drying out, cracking, tearing or improper tracking, it should be replaced. To replace the drive belt, unscrew and open the belt cover on the left (Fig. 16). Install new belt (part no. 20653-034, available for purchase at [wenproducts.com](http://wenproducts.com)) and replace drive belt cover.

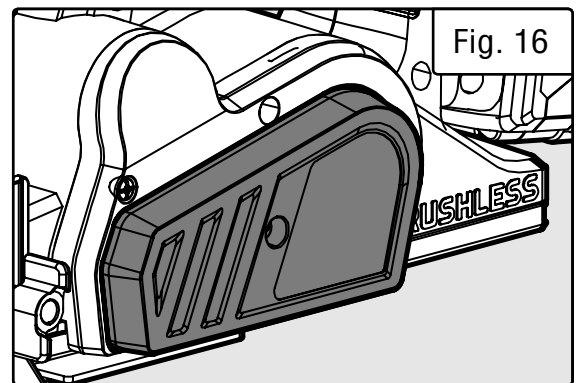

# EXPLODED VIEW & PARTS LIST

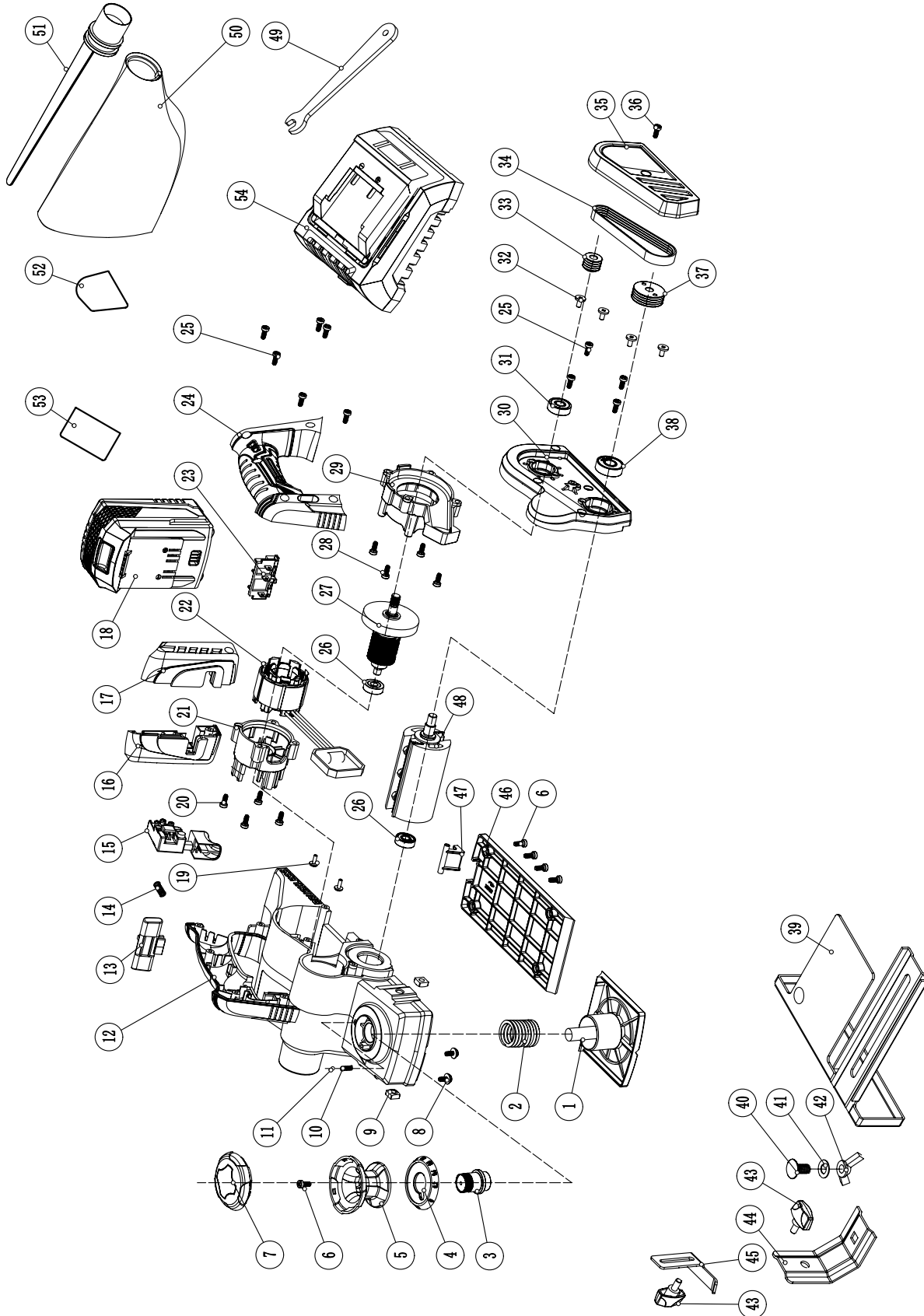

**NOTE:** Not all parts may be available for purchase. Parts and accessories that wear down over the course of normal use are not covered under the warranty.

## **EXPLODED VIEW & PARTS LIST**

No.	Part No.	Description	Qty.	No.	Part No.	Description	Qty.
1		Front Shoe	1	26		Bearing, 607-2RS	2
2		Front Shoe Spring	1	27		Rotor	1
3		Depth Regulating Shaft	1	28		Screw, M4x20	4
4		Depth Gauge Ring	1	29		Left Motor Housing	1
5		Depth Knob	1	30		Belt Cover Plate	1
6		Screw, ST4x16	5	31		Bearing, 608-2RS	1
7		Knob Cover	1	32		Flat Head Screw, M4x8	4
8		Screw with Washer, ST4x10	2	33		Driving Pulley	1
9		Square Nut, M6	2	34	20653-034	Drive Belt, 4-EPJ230	1
10		Ball Spring	1	35		Belt Cover	1
11		Ball, 3.5mm	1	36		Screw, M4x10	1
12		Housing	1	37		Driven Pulley	1
13		Lock Off Switch	1	38		Bearing, 6000-2RS	1
14		Lock Off Switch Spring	1	39	6530-061	Parallel Guide Fence	1
15		Switch	1	40		Bolt, M6x12	1
16		Right Battery Terminal Housing	1	41		Washer, 6mm	1
17		Left Battery Terminal Housing	1	42		Wing Nut, M6	1
18	20204	20V 4.0Ah Battery	1	43		Knob	2
19		Screw with Washer, ST3x10	2	44	6530-059	Fence Bracket	1
20		Screw, ST4x25	4	45		Rabbeting Guide	1
21		Right Motor Housing	1	46		Rear Shoe	1
22		Stator & PCB	1	47		Kickstand	1
23		Battery Terminal	1	48		Cutterhead	1
24		Handle	1	49		Wrench	1
25		Screw, ST4x16	10	50		Dust Bag Assembly	1
				51			
				52		Label 1	1
				53		Label 2	1
				54	20200C	Charger	1

**NOTE:** Not all parts may be available for purchase. Parts and accessories that wear down over the course of normal use are not covered under the warranty.



## **WARRANTY STATEMENT**

WEN Products is committed to building tools that are dependable for years. Our warranties are consistent with this commitment and our dedication to quality.

### **LIMITED WARRANTY OF WEN PRODUCTS FOR HOME USE**

GREAT LAKES TECHNOLOGIES, LLC (“Seller”) warrants to the original purchaser only, that all WEN consumer power tools will be free from defects in material or workmanship during personal use for a period of two (2) years from date of purchase or 500 hours of use; whichever comes first. Ninety days for all WEN products if the tool is used for professional or commercial use. Purchaser has 30 days from the date of purchase to report missing or damaged parts.

**SELLER’S SOLE OBLIGATION AND YOUR EXCLUSIVE REMEDY** under this Limited Warranty and, to the extent permitted by law, any warranty or condition implied by law, shall be the replacement of parts, without charge, which are defective in material or workmanship and which have not been subjected to misuse, alteration, careless handling, misrepair, abuse, neglect, normal wear and tear, improper maintenance, or other conditions adversely affecting the Product or the component of the Product, whether by accident or intentionally, by persons other than Seller. To make a claim under this Limited Warranty, you must make sure to keep a copy of your proof of purchase that clearly defines the Date of Purchase (month and year) and the Place of Purchase. Place of Purchase must be a direct vendor of Great Lakes Technologies, LLC. Purchasing through third party vendors, including but not limited to garage sales, pawn shops, resale shops, or any other secondhand merchant, voids the warranty included with this product. Contact [techsupport@wenproducts.com](mailto:techsupport@wenproducts.com) or 1-800-232-1195 with the following information to make arrangements: your shipping address, phone number, serial number, required part numbers, and proof of purchase. Damaged or defective parts and products may need to be sent to WEN before the replacements can be shipped out.

Upon the confirmation of a WEN representative, your product may qualify for repairs and service work. When returning a product for warranty service, the shipping charges must be prepaid by the purchaser. The product must be shipped in its original container (or an equivalent), properly packed to withstand the hazards of shipment. The product must be fully insured with a copy of the proof of purchase enclosed. There must also be a description of the problem in order to help our repairs department diagnose and fix the issue. Repairs will be made and the product will be returned and shipped back to the purchaser at no charge for addresses within the contiguous United States.

THIS LIMITED WARRANTY DOES NOT APPLY TO ITEMS THAT WEAR OUT FROM REGULAR USAGE OVER TIME, INCLUDING BELTS, BRUSHES, BLADES, BATTERIES, ETC. ANY IMPLIED WARRANTIES SHALL BE LIMITED IN DURATION TO TWO (2) YEARS FROM DATE OF PURCHASE. SOME STATES IN THE U.S. AND SOME CANADIAN PROVINCES DO NOT ALLOW LIMITATIONS ON HOW LONG AN IMPLIED WARRANTY LASTS, SO THE ABOVE LIMITATION MAY NOT APPLY TO YOU.

IN NO EVENT SHALL SELLER BE LIABLE FOR ANY INCIDENTAL OR CONSEQUENTIAL DAMAGES (INCLUDING BUT NOT LIMITED TO LIABILITY FOR LOSS OF PROFITS) ARISING FROM THE SALE OR USE OF THIS PRODUCT. SOME STATES IN THE U.S. AND SOME CANADIAN PROVINCES DO NOT ALLOW THE EXCLUSION OR LIMITATION OF INCIDENTAL OR CONSEQUENTIAL DAMAGES, SO THE ABOVE LIMITATION OR EXCLUSION MAY NOT APPLY TO YOU.

THIS LIMITED WARRANTY GIVES YOU SPECIFIC LEGAL RIGHTS, AND YOU MAY ALSO HAVE OTHER RIGHTS WHICH VARY FROM STATE TO STATE IN THE U.S., PROVINCE TO PROVINCE IN CANADA AND FROM COUNTRY TO COUNTRY.

THIS LIMITED WARRANTY APPLIES ONLY TO ITEMS SOLD WITHIN THE UNITED STATES OF AMERICA, CANADA AND THE COMMONWEALTH OF PUERTO RICO. FOR WARRANTY COVERAGE WITHIN OTHER COUNTRIES, CONTACT THE WEN CUSTOMER SUPPORT LINE. FOR WARRANTY PARTS OR PRODUCTS REPAIRED UNDER WARRANTY SHIPPING TO ADDRESSES OUTSIDE OF THE CONTIGUOUS UNITED STATES, ADDITIONAL SHIPPING CHARGES MAY APPLY.





**THANKS FOR  
REMEMBERING**

