

Superior quality since
1984



Owners Manual

50,000KG AIR ACTUATED JACK

BORUM

INDUSTRIAL WORKSHOP EQUIPMENT

**INDUSTRIAL
QUALITY**



Specifications

AIR ACTUATED JACK 3 STAGE 10,000/25,000/50,000KG

- First Stage: 50,000kg Safe Working Capacity
- Second Stage: 25,000kg Safe Working Capacity
- Third Stage: 10,000kg Safe Working Capacity
- First Stage Hydraulic Lift: 62mm
- Second Stage Hydraulic Lift: 61mm
- Third Stage Hydraulic Lift: 69mm
- Minimum Height: 160mm
- Maximum Height: 472mm
- Adaptors: 45mm and 75mm
- Handle Length: 1380mm
- Operating Air Pressure: 145-175psi
- Chassis: 825x282x160mm
- Nett Weight: 61kg

About the Borum brand

Our **“heavy duty commercial”** range of Borum Industrial equipment has been manufactured to exacting standards for the past **34 years**. We specify industrial quality components and design to ensure a long and durable working life in **commercial transport, mining, earthmoving and railway** environments. Our Borum Industrial range of equipment is focused on achieving superior professional standards, reliability, quality, and are covered by a **12 month trade use warrant**.

WARNING INFORMATION



IMPORTANT: READ ALL INSTRUCTIONS BEFORE USE

 **WARNING**

The instructions and warnings contained in this manual should be read and understood before using or operating this equipment. Do not allow anyone to use or operate this equipment until they have read this manual and have developed a thorough understanding of how this equipment works. Failure to observe any of the instructions contained in the manual could result in severe personal injury to the user or bystanders, or cause damage to the equipment and property. Keep this manual in a convenient and safe place for future reference.

The warnings, cautions and instructions discussed in this instruction manual cannot cover all possible conditions and situations that may occur. It must be understood by the operator that common sense and caution are factors which cannot be built into this product, but must be supplied by the operator.

Whilst every effort has been made to ensure accuracy of information contained in this manual, the Borum policy of continuous improvement determines the right to make modifications without prior warning.

CONTENTS

WARNING INFORMATION	1
CONTENTS	1
STANDARD OPERATING PROCEDURE	2
ASSEMBLY, OPERATION, PREVENTITIVE MAINTENANCE	3
TROUBLESHOOTING	7
WARRANTY	8

STANDARD OPERATING PROCEDURE

DO NOT use this machine unless you have been trained and assessed to a competent level in its safe use and operation, and have been given permission to use this



Safety glasses must be worn when operating this equipment



Long loose hair must be contained when operating this equipment



Safety footwear must be worn when operating this equipment



Close fitting/protective clothing must be worn when operating this equipment



Safety gloves must be worn when operating this equipment

PRE-OPERATIONAL SAFETY CHECKS

1. Support load by appropriate means after lifting
2. Do not exceed rated capacity
3. Centre load on the jack
4. Only use attachments and/or adapters supplied with or sold specifically for the jack
5. Only lift areas of the vehicle designated by the vehicle manufacturer.
6. Use as lifting device only
7. Use only on hard, level surface
8. Do not modify jack

OPERATIONAL SAFETY CHECKS

1. This jack should be used for lifting and lowering only. The raised load should be supported on approved support stands. No person should get any part of the body under a load that is supported by this jack.
2. Position the jack to only lift on the areas of the load specified by the manufacturer.
3. Use support stands – after lifting the load always support the load with appropriately rated support stands before working on the load.
4. Do not overload this jack beyond its rated capacity. Overloading this jack beyond its rated capacity can cause damage to or failure of the jack.
5. Use only on hard level surfaces capable of sustaining the load. Use on other than hard level surfaces can result in jack instability and possible loss of load.
6. Centre load on jack saddle before lifting vehicle.
7. Off centre loads and loads lifted when the jack is not level can cause loss of load or damage to the jack.
8. Keep hands & feet clear of the jack hinge mechanism & ground contact area when lowering the load.
9. NEVER LIFT THE LOAD OFF AIRBAG BRACKETS. ALWAYS LIFT OFF AN AXLE OR CHASSIS LIFT POINT
10. Use a qualified person to maintain the jack in good condition. Keep it clean for best and safest performance.

THIS JACK IS A LIFTING DEVICE ONLY & IS DESIGNED FOR LIFTING PART OF THE TOTAL VEHICLE/LOAD. DO NOT MOVE OR DOLLY THE VEHICLE/LOAD WHILST THE VEHICLE/LOAD IS ON THE JACK.

ASSEMBLY, OPERATION, PREVENTITIVE MAINTENANCE

1. FEATURES

The **BORUM "Industrial Quality"** Commercial Jacks are made to TQB Brands specification using quality components that are built to exacting standards through CNC machining and Robotic Welding. The result is top industrial performance and reliability. BORUM "Industrial Quality" Commercial Jacks are the perfect choice for a wide variety of uses. These Commercial Jacks are carefully constructed from the highest grades of rugged steel. The super strong hydraulic pump utilises wear-resistant American Made XTP double sealing ring technology. Only the finest quality of Hydraulic Oil is used that has been tested from -25°C - 60°C.

Use these workhorses with a 145–175psi rated air pressure supply to lighten the load and provide the fast, strong lifting power you need. With several lifting options as well as included saddle adaptors...the wide range of BORUM Commercial Jacks will suit most desired applications from agriculture to mining, earth-moving to passenger transport as well as aviation and military.

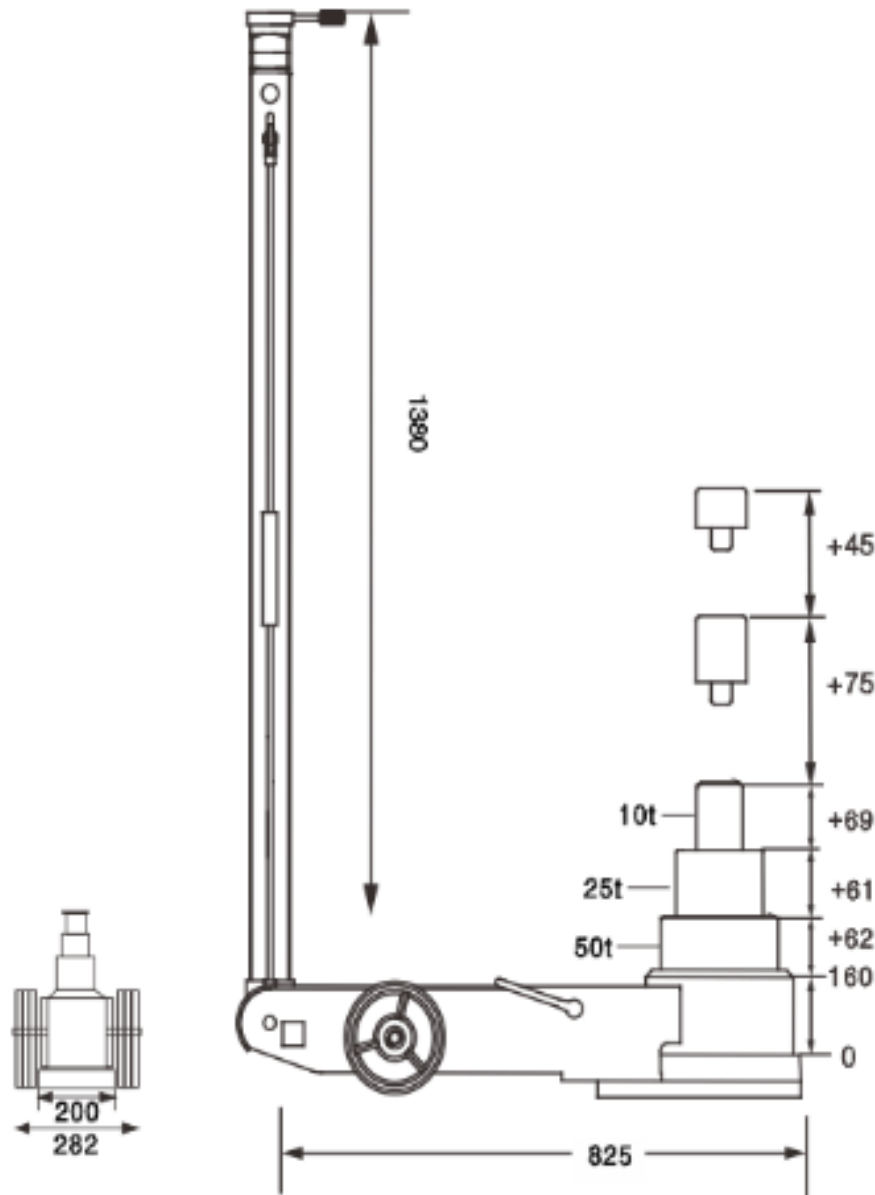

2. ASSEMBLY

Step 1: Screw toggle (taped to bottom of carton with handle in) into the top of the handle.
Remove axle from rear of jack.

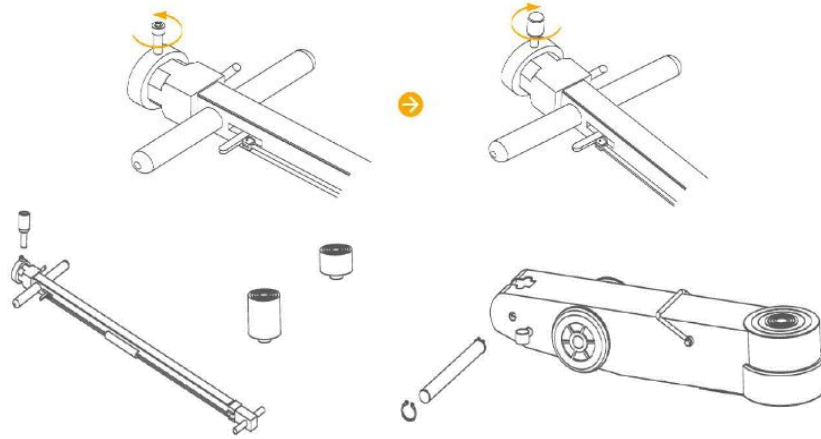

Step 2: Insert hoses from Handle into rear of jack as pictured below.

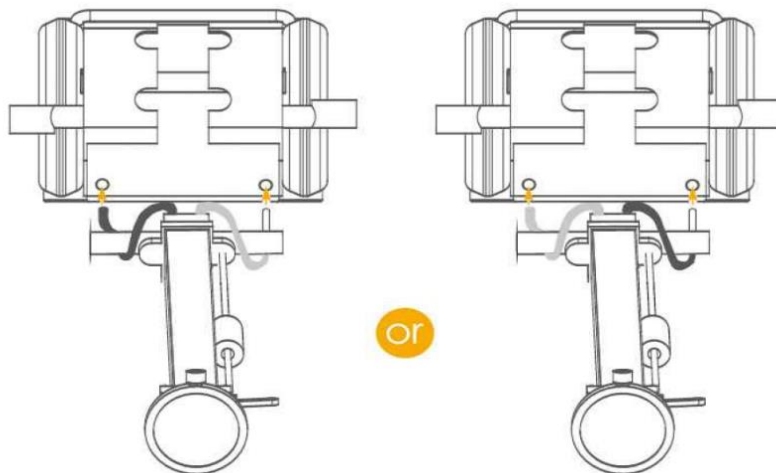

Step 3: Insert handle base into slot and thread axle through jack and handle.
Lock in place with circlip

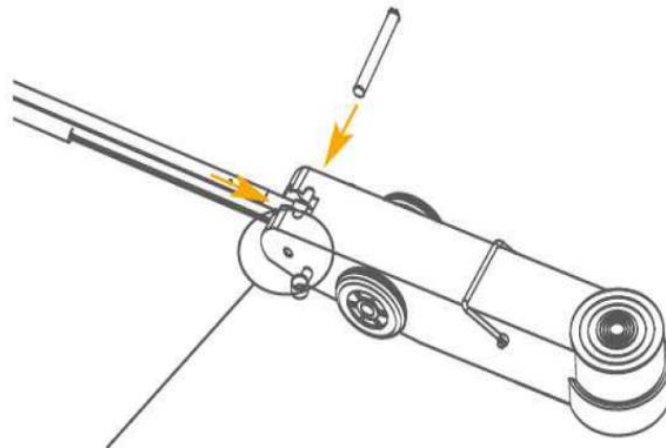

PLEASE NOTE:
TO LOWER THE JACK, THE SAME AMOUNT OF FREE AIR FLOW IS REQUIRED AS WHEN LIFTING

3. BEFORE USE

Prior to each use conduct a visual inspection checking for abnormal conditions, such as cracked welds, leaks, and damaged, loose, or missing parts.

- Consult the vehicle owner's manual to determine the location of lift points.
- Be sure to set the vehicle in park with the emergency brake on and wheels securely chocked.
- Be sure that the vehicle and the jack are on a hard, level surface.

4. OPERATION

1. This jack is equipped with a handle position lock. To adjust the handle, release the lock device by pulling the lever up. The lever is spring loaded so, so it should lock into the desired position.
2. Make sure the jack and load are on a hard level surface.
3. Always set the vehicle parking brake and block the wheels.
4. Check the placement of the jack. The load must be centered on the jack saddle. Avoid jack wheel obstructions such as gravel, tools, or uneven expansion joints.
5. Position the jack under the load using the manufacturer's recommended lifting points on the chassis.
6. Connect compressed air supply to the jack. (Compressed air should be clean, dry, and regulated at 120-170psi). Install an air filter/lubricator in the workshop air-line, because water in the airline will damage the jack.
7. Rotate the lever RIGHT to the UP position. (To stop air operation, simply release the grip on the lift control trigger). Continue to pump the jack until the head cap reaches the load.
8. Before raising the load, double check and verify the saddle is centred and has full contact with the specified lifting point.
9. Rotate the lever RIGHT to the UP position (To stop air operation, simply release the grip on the lift control trigger). Continue to pump the jack to lift the load to the desired height.
10. Always immediately position approved support stands under the load at points that will provide stable support in accordance with the vehicle or load manufactures recommendations.
11. Always lower the load slowly onto the support stands by rotating the lever LEFT to the DOWN position.
12. Carefully lower the load onto the support stands by rotating the lever to the DOWN position

Lowering the Load

1. Raise the load by following Steps 2-9
2. Raise the load high enough to allow clearance for the support stands to be removed by rotating the lever to the Right UP position.
3. Carefully remove the support stands
4. Grasp the jack handle firmly. Securely hold onto the jack handle so that your hands do not slip and ensure the release valve does not lower rapidly.
5. Carefully open the release valve by slowly rotating the LEVER to the LEFT DOWN position.
6. Once the load has been lowered, remove the jack from beneath the load, and fully retract the ram to prevent exposure to dirt and grime.

5. INSPECTION

- Prior to each use conduct a visual inspection checking for abnormal conditions, such as cracked welds, leaks, and damaged, loose, or missing parts.
- The jack shall always be maintained in accordance with the maintenance instructions (Section 7). No alterations or modifications shall be made to this Jack.
- Inspections shall be performed in accordance with this owner's manual.
- The jack must be inspected immediately if it is believed to have been subjected to abnormal load or shock.
- Owners and /or operators should be aware that repair of this product may require specialised equipment and knowledge (refer to maintenance section).

6. STORAGE

This Borum jack should always be stored in a dry location on a level surface with the lift ram pistons in the fully retracted position, where it will not be exposed to corrosive vapours, abrasive dust, or any other harmful elements.

7. MAINTENANCE

Monthly maintenance is recommended. Lubrication is critical to jacks as they support heavy loads. Any restriction due to dirt, rust, etc, can cause either slow movement or cause extremely rapid jerks damaging the internal components. The following steps are designed to keep the jack well maintained and operational.

Important: Dirt is the greatest single cause of failure in hydraulic units. Keep the jack clean and well lubricated to prevent foreign matter from entering the system. If the jack has been exposed to rain, snow, sand, or grit it must be cleaned before it is stored or used.

- Only use replacement parts that are approved by the manufacturer. Disconnect the air supply before performing any maintenance operation.
- Lubricate the ram, linkages, saddle, wheels and pump mechanism with light Hydraulic oil.
- Visually inspect for cracked welds, bent, loose, missing parts or hydraulic oil leaks.
- Any hydraulic jack found to be damaged, worn or operates abnormally must be removed from service until repaired by an authorised service representative.
- Regularly clean all surfaces and maintain all labels and warnings.
- Check and maintain the hydraulic ram oil level.
- Check the ram every three months for any sign of rust or corrosion. Clean as needed and wipe with a clean oily cloth. When not in use always leave the saddle and ram all the way down.
- Always store your jack in the fully retracted position. This will help protect critical areas from corrosion. Do not use brake or transmission fluids or regular motor oil as they can damage the seals.

ONLY USE HIGH QUALITY HYDRAULIC FLUID – ISO68

8. SERVICE & REPAIR

Any Borum jack found damaged in any way, or found to be worn or operates abnormally should be removed from service until repaired by an authorised service agent. Owners and / or operators should be aware that repair of this product may require specialised equipment and knowledge. Only authorised parts, labels, decals shall be used on this equipment. Annual inspection of the jack is recommended and can be made by an authorised repair facility to ensure that your equipment is in optimum condition and that the equipment has the correct decals and safety labels specified by the manufacturer.

TROUBLESHOOTING

PROBLEM	POSSIBLE CAUSE	ACTION
Jack will not lift	<ul style="list-style-type: none"> • Control valve in wrong position. • Low/no oil in reservoir. • Air-locked system. • Load is above capacity of jack. • Delivery valve and/or bypass valve not working correctly. • Seals worn out or defective. • Not enough air pressure 	<ul style="list-style-type: none"> • Turn control valve knob clockwise. • Fill with oil and bleed system. • Bleed system. • Use correct equipment. • Clean to remove dirt or foreign matter. Replace oil. • Install appropriate seal kit. • Ensure constant air delivery of above 120psi
Jack lifts only partially	<ul style="list-style-type: none"> • Too much or not enough oil 	<ul style="list-style-type: none"> • <i>Check oil level</i>
Jack advances slowly	<ul style="list-style-type: none"> • Pump not working correctly • Leaking seals 	<ul style="list-style-type: none"> • <i>Install seal kit, or replace power unit</i> • <i>Install seal kit</i>
Jack lifts load, but doesn't hold	<ul style="list-style-type: none"> • Cylinder packing is leaking • Valve not working correctly (suction, delivery, release or bypass). • Air-locked system 	<ul style="list-style-type: none"> • <i>Install seal kit</i> • <i>Inspect valves. Clean and repair seat surfaces</i> • <i>Bleed system as per instructions</i>
Jack leaks oil	<ul style="list-style-type: none"> • Worn or damaged seals 	<ul style="list-style-type: none"> • <i>Install seal kit</i>
Jack will not retract	<ul style="list-style-type: none"> • Control valve in wrong position • Air Pressure to low 	<ul style="list-style-type: none"> • <i>Move Control valve to DOWN position</i> • <i>Ensure constant air delivery of above 120psi</i>
Jack retracts slowly	<ul style="list-style-type: none"> • Cylinder damaged internally 	<ul style="list-style-type: none"> • <i>Send jack to authorised service centre</i>

PLEASE NOTE:

TO LOWER THE JACK, THE SAME AMOUNT OF FREE AIR FLOW IS REQUIRED AS WHEN LIFTING

WARRANTY

BORUM Industrial products have been carefully tested and inspected before shipment and are guaranteed to be free from defective materials and workmanship for a period of 12 months from the date of purchase except where tools are hired out when the guarantee period is ninety days from the date of purchase.

Should this piece of equipment develop any fault, please return the complete tool to your nearest authorised warranty repair agent or contact TQB Brands Pty Ltd Warranty team – warranty@tqbbrands.com.au.

If upon inspection it is found that the fault occurring is due to defective materials or workmanship, repairs will be carried out free of charge. This guarantee does not apply to normal wear and tear, nor does it cover any damage caused by misuse, careless or unsafe handling, alterations, accident, or repairs attempted or made by any personnel other than the authorised TQB Brands Pty Ltd repair agent.

This guarantee applies in lieu of any other guarantee expressed or implied and variations of its terms are not authorised.

Your TQB Brands Pty Ltd guarantee is not effective unless you can produce upon request a dated receipt or invoice to verify your proof of purchase within the 12month period.

Consumer Guarantee

Our goods come with a guarantee that cannot be excluded under the Australian Consumer Law. You are entitled to a replacement or refund for a major failure and compensation for any other reasonably foreseeable loss or damage. You are also entitled to have the goods repaired or replaced if the goods fail to be of acceptable quality and the failure does not amount to a major failure.



All images and illustrations shown are for reference purposes only. All information, specifications and illustrations in this manual are based on the latest information available at the time of publication and are subject to change without notice. The information in this manual is periodically revised to ensure the latest information is included. Download the latest version of this manual and other related technical documentation from www.tqbbrands.com.au