

DUSK TO DAWN LED LIGHT



FEATURES

- IP65 rated, built-in Dusk to Dawn Photocell function
- Easy installation and maintenance
- Corrosion and rust proof
- 50,000 hours lifetime

SUITABLE APPLICATIONS

- Area Lighting
- Barn Lighting
- House Lighting
- Building Lighting
- Warehouse Lighting
- Wall Lighting



CONSTRUCTION:

- Heavy die-cast aluminum alloy housing with bronze powder-coated finish.

OPTICAL SYSTEM:

- Lumileds 3030LED chips
- High quality frosted PC cover optics
- 135° beam angle

WARRANTY:

5-year limited warranty. Actual performance may differ as a result of end-user environment and application.

ELECTRICAL:

- Available as 120-277V input
- -4°F to 113°F

INSTALLATION & MOUNTING:

Wall mount / Bend pipe pole mounting for easy installation.

PERFORMANCE

Model NO	Photocell Control	Wattage	Voltage/Current Input		Light Efficiency	Kelvin Options
			120V	277V		
LS-STL40W-50K	3fcON/ 13fc OFF	40W	0.29A	0.12A	130LM/W	5000K

Dusk to Dawn LED Light

Photocell Control



Built in Photocell function

Motion Sensor



Occupancy Motion Sensor options

► Electric Characteristic

Specification/Model	LDS-2STL-40W-120V-50K
LED Driver	UL listed KHM Brand
Input Power	40W
Lumens Output	5200LM
Efficiency	130LM/W
CRI	> 72
Color Temperature	5000K
Input Voltage	120-277VAC
Light Distribution Type	135D
Working Temperature	-4 ~ +113°F
Junction Temperature	< 167°F
Lamps Efficiency	≥ 90%
Certificate	ETL CETL DLC
Equivalent	80-100W MH/HPS

► Dimension

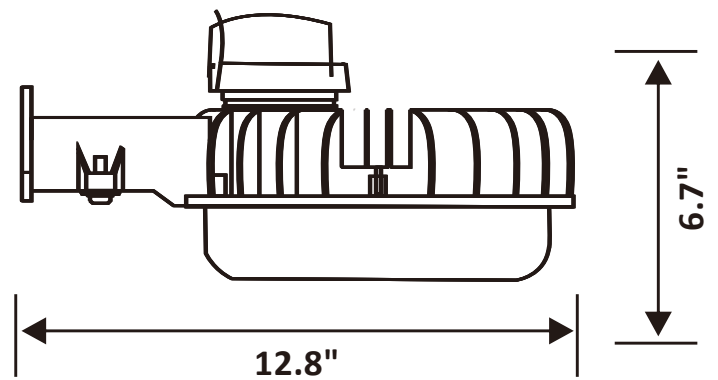

Dusk to Dawn LED Light

Distribution Diagram

LDS-2STL-40W-120V-50K

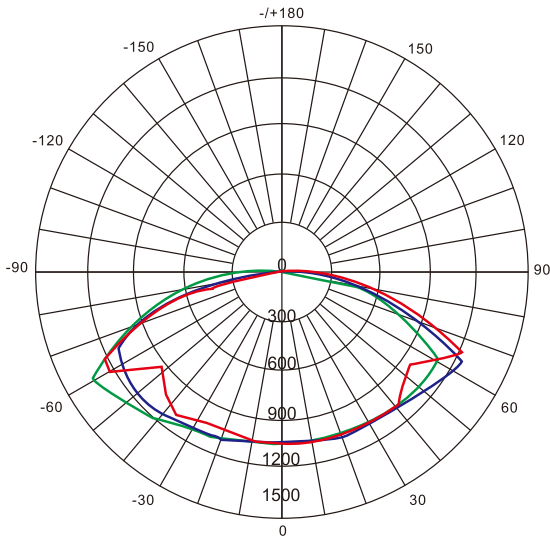

AVERAGE BEAM ANGLE (50%): 135°

UNIT:CD

Test Number: LS-STL40W-50K
 Lumens: 5200LM
 Test Number: 40W
 Test Number: 5000K

— C0/180,135
 — C30/210,104
 — C60/240,104.5
 — C90/270,135.2

Installation Instruction

1. Dusk-to-dawn LED Outdoor Barn Light luminaire features a design that can be mounted to any vertical surface using lag bolts or other comparable and suitable anchors, with a wiring compartment that is easily accessible without the need to remove the lens or disassemble the fixture.
2. Dusk-to-dawn LED Outdoor Barn Light can also be mounted to existing 1-1/2" or 1-5/8" pipe mounts, offering the installer the flexibility to satisfy many different mounting applications and requirements.
3. This is especially useful when using the LED Outdoor Barn Light to retrofit older dusk-to dawn luminaires.

Wall Mounting

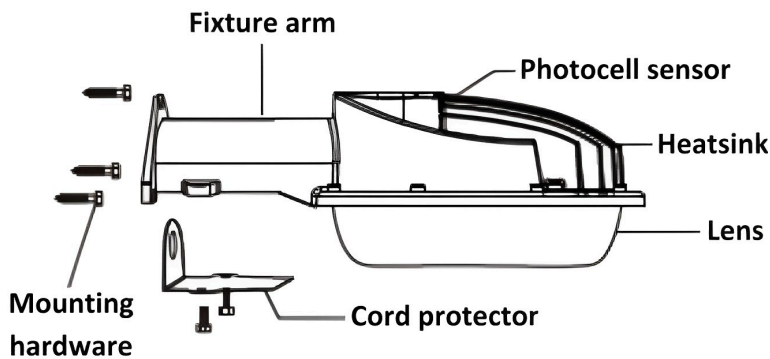

Arm Mounting

